

# WIPLINE FLOATS

## MODEL 2350

## PARTS MANUAL



# CESSNA 172

THIS PAGE INTENTIONALLY LEFT BLANK

## TABLE OF CONTENTS

<u>SECTION</u>	<u>PAGE</u>
LOG OF REVISIONS .....	5
FLOAT PART SALES DEPT. OPERATIONS.....	6
PARTS ORDERING .....	6
DAMAGED GOODS .....	6
RETURNED PARTS.....	6
ORDER SHORTAGES .....	7
CREDIT POLICY .....	7
LIST OF ABBREVIATIONS.....	7
NEW CUSTOMER INFORMATION .....	8
SECTION 1: HULL ASSEMBLY - AMPHIBIAN AND STRAIGHT .....	10
HULL ASSEMBLY - AMPHIBIAN .....	11
HULL ASSEMBLY – SEAPLANE .....	17
TOP SKIN – HULL – AMPHIBIAN.....	23
TOP SKIN – HULL – SEAPLANE.....	27
SECTION 2: WHEEL WELL ASSEMBLY - AMPHIBIAN.....	30
WHEEL WELL ASSEMBLY – AMPHIBIAN .....	31
SECTION 3: HULL EXTRUSIONS - AMPHIBIAN AND STRAIGHT.....	34
EXTRUSIONS – HULL – AMPHIBIAN.....	35
EXTRUSIONS – HULL – SEAPLANE .....	37
SECTION 4: PUMPER TUBE INSTALLATION.....	40
PUMPER TUBE INSTALLATION .....	41
SECTION 5: WATER RUDDER INSTALLATION.....	44
INSTALLATION WATER RUDDER.....	45
SECTION 6: NOSE GEAR ASSEMBLY.....	48
ASSEMBLY – NOSE GEAR RETRACTION.....	49
ASSEMBLY – NOSE GEAR – LOWER.....	51
ASSEMBLY – NOSE WHEEL (GROVE) .....	53
ASSEMBLY – NOSE WHEEL (PARKER) .....	55
SECTION 7: MAIN GEAR ASSEMBLY .....	58

**WIPLINE MODEL 2350 FLOAT PARTS MANUAL**

INSTALLATION MAIN GEAR RETRACTION.....	59
ASSEMBLY MAIN GEAR WHEEL – CLEVELAND/PARKER.....	63
ASSEMBLY – MAIN GEAR WHEEL – GROVE/WIPAIRE.....	67
SECTION 8: INSTALLATION – STRUTS, WIRES, SPREADER BARS, STEPS.....	70
INSTALLATION – STRUTS, WIRES AND SPREADER BARS - CESSNA 172 .....	71
INSTALLATION – FUSELAGE STEPS - CESSNA 172 .....	75
SECTION 9: STEERING AND RETRACT SYSTEM – CESSNA 172 .....	78
ASSEMBLY – RETRACT HANDLE CESSNA 172 .....	79
INSTALLATION – STEERING AND RETRACT SYSTEM CESSNA 172 .....	81
SECTION 10: INSTALLATION - HYDRAULIC SYSTEM .....	84
INSTALLATION – HYDRAULIC SYSTEM CESSNA 172 .....	85
ASSEMBLY – HYDRAULIC PUMP .....	89
HYDRAULIC SCHEMATIC.....	93
SECTION 11: ELECTRICAL SCHEMATIC .....	96
ELECTRICAL SCHEMATIC .....	97
SECTION 12: GEAR CONTROL.....	100
GEAR CONTROL (ROUND) .....	101
GEAR CONTROL (RECTANGLE).....	103
SECTION 13: HYDRAULIC PUMP .....	106
HYDRAULIC PUMP .....	107

**NOTE:**

**Any information not found in this manual for strut package parts and other aircraft installation items, refer to the installation drawing package provided with the STC at the time of float installation. Additional drawing copies are available for purchase through the Wipaire Customer Service department.**

**LOG OF REVISIONS**

Revision	Pages effected	Description	Date
A	53-59	ADDED GROVE – WIPAIRE DRAWING AND PARTS LIST AND REVISED TABLE OF CONTENTS	12/12/05
B	42, 50	NOSE AND MAIN GEAR RETRACTION CYLINDER P/N CHANGED	3/20/06
C	20-26	CHANGED FLOAT DECK P/NS.	8/3/06
D	50 ALL 61 62	CHANGED P/NS FOR MAIN GEAR BUSHINGS ADDED PART UMBER AND REVISION TO ALL PAGES REF 4 – DRAG WIRE 1002111 WAS 21A02000-136 REF 10–WIRE PULL 21A02462-005 WAS 21A02519-008	11/3/06
E	44, 51	HYDRAULIC CYLINDER PART NUMBERS CHANGED.	7/21/07
F	MULTIPLE PAGES UPDATED	MANY PAGES CHANGED WITH UPDATED PART NUMBERS FOR PARTS. NEW FIGURE ADDED FOR WATER RUDDER.	9/1/10
G	ALL	REFORMATTED ENTIRE MANUAL, UPDATE TO PART SALES DEPT PAGE, ADDED NEW WARRANTY AND CUSTOMER INFORMATION, UPDATED HYD. PUMP, GEAR SELECTOR, STRUT, STEP, STEERING/RETRACT, WIRES AND SPREADER BAR, ELECTRICAL SCHEMATIC IMAGES AND BOMS, CORRECTED MULTIPLE CLERICAL ERRORS AND INCORRECT PART/ITEM CALLOUTS, ADDED GROVE NOSE WHEEL, WASHER 415067 WAS 359071, REPLACED NOSE GEAR RETRACTION FIG. 10 AND BOM, REPLACED WATER RUDDER FIG. 9 AND BOM.	7/7/2014
H	3	Removed Warranty Claim Form	3/31/16

## FLOAT PART SALES DEPT. OPERATIONS

Hours: 7:00 AM – 6:00 PM, Monday through Friday  
Central U.S. Time

Phone: 651-306-0459

Fax: 651-306-0666

Email: [customerservice@wipaire.com](mailto:customerservice@wipaire.com)

Website: [www.wipaire.com](http://www.wipaire.com)

### SHIPPING SCHEDULE:

In-stock orders received before 3:00 PM CST ship the same day. Orders received after this time may be assessed an AOG fee for special priority handling.

As we are primarily a manufacturer, our stocks can be rapidly depleted by production requirements. Therefore, prices and availability are subject to change at any time. It is our intent to provide courteous and prompt service of your needs. Please let us know of any problem or concerns so that changes in these procedures can be a benefit to all.

### PARTS ORDERING

Purchase orders should include

1. P.O. Number
2. Name of person placing order
3. Invoicing information:
  - I. Customer name – company or individual
    - i. Address
    - ii. Phone and fax number
4. Shipping information:
  - I. Address (if different from invoice address)
  - II. Method of shipment/preferred carrier
5. Aircraft model, float model and serial numbers
6. Wipaire part number; name; type, e.g. left or right; quantity
7. Payment method: VIS A, MasterCard, COD (U.S. customers only). Pre-payment by check or wire transfer, open account (see credit policy section).

### DAMAGED GOODS

Inspect all parts upon receipt. Damages to parts in transit must be filed as a claim against the carrier.

### RETURNED PARTS

Written explanation of reason for return must accompany parts, including invoice number of original shipment. Shipping charges on returned parts must be prepaid or the shipment will be refused.

## ORDER SHORTAGES

Check shipment against delivery slip immediately. All claims for any shortages should be made within three (3) days after order receipt.

## CREDIT POLICY

Parts will be shipped on open account, net 30 days, to Wipaire-approved credit customers only. A balance due over 60 days will result in no shipments. Wipaire, Inc reserves the right to send any order C.O.D.

## LIST OF ABBREVIATIONS

All references in this manual to LEFT and RIG HT are from the perspective of the pilot's seat with the floats fully installed and ready for floatplane operation. The following is a list of abbreviations that may appear in the description nomenclature fields of this manual:

AB	AFTERBODY	INBD.	INBOARD
ALUM	ALUMINUM	LG.	LARGE.
AMPHIB.	AMPHIBIOUS	LT.	LEFT
AR	AS REQUIRED	LWR.	LOWER
ASS'Y.	ASSEMBLY	OPT.	OPTIONAL
BRKT.	BRACKET	OTBD.	OUTBOARD
BTM.	BOTTOM	REINF.	REINFORCEMENT
BULK.	BULKHEAD	RR.	REAR
CTR.	CENTER	RT.	RIGHT
CYL.	CYLINDER	SM.	SMALL
FT.	FRONT	SN	SERIAL NUMBER
FTG.	FITTING	SPR.	SPREADER
FUS.	FUSELAGE	UPR.	UPPER
FWD.	FORWARD	VERT.	VERTICAL
HORIZ.	HORIZONTAL	W.W.	WHEEL WELL
HYD.	HYDRAULIC		



**NEW CUSTOMER INFORMATION**

<b>Customer Name</b>	
<b>Billing Address</b>	
<b>Shipping address</b>	
Phone Number	Fax Number
Purchasing Contact	Phone Number
E-Mail	Fax Number
Accounts Payable Contact	Phone Number
E-Mail	Fax Number
Type(s) of Floats and Skis owned or Maintained	
Models(s) of Floats and Skis owned or Maintained	
FedEx and/or UPS account number (if applicable)	

Please return to Wipaire Customer Service:

Fax 651-306-0666

Phone 651-306-0459

CustomerService@wipaire.com



THIS PAGE INTENTIONALLY LEFT BLANK

**SECTION 1: HULL ASSEMBLY - AMPHIBIAN AND STRAIGHT**

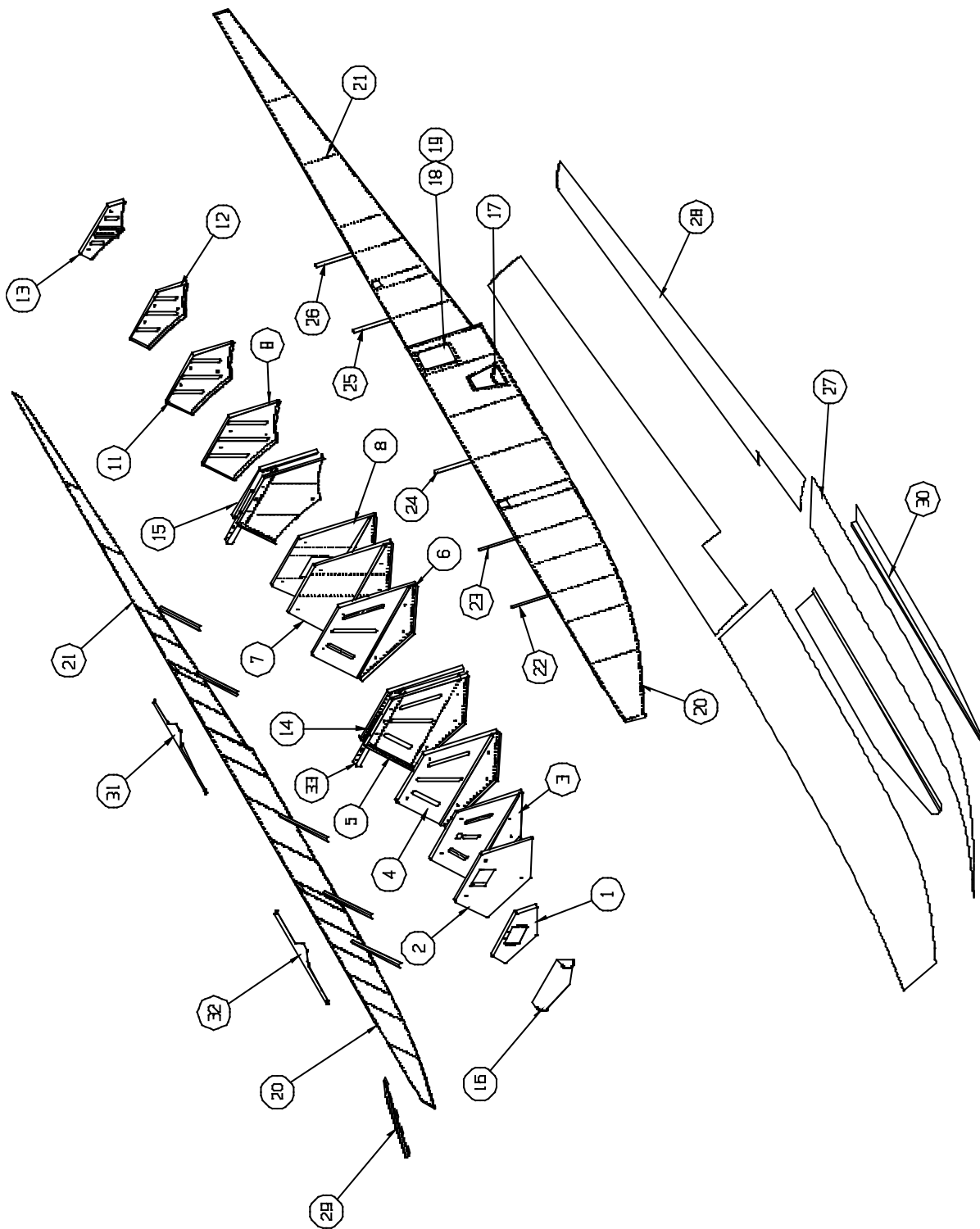

**HULL ASSEMBLY - AMPHIBIAN**  
FIGURE 1

**WIPLINE MODEL 2350 FLOAT PARTS MANUAL**

<b>FIGURE 1: HULL ASSEMBLY-AMPHIBIAN</b>			
<b>ITEM</b>	<b>QTY</b>	<b>PART DESCRIPTION</b>	<b>PART NO.</b>
1	1	BULKHEAD #1	21A01163-067
2	1	ASSY BULKHEAD #3	21A01000-265
	1	BULKHEAD	21A01158-184
	1	ANGLE – NOSE BOX ATTACH	21A01326-006
	1	ANGLE – NOSE BOX ATTACH	21A01326-005
3	1	ASSY BULKHEAD #4	21A01000-261
	1	BULKHEAD – MAIN	21A01158-174
	1	SUPPORT – BULKHEAD LOWER	21A01158-175
	1	CLAMP – PUMP OUT TUBE	3A01158-003
4	1	ASSY BULKHEAD #5	23A01000-296
	1	BULKHEAD - MAIN	23A01158-196
	1	SUPPORT – BULKHEAD LOWER	21A01158-176
	1	CLAMP – PUMP OUT TUBE	3A01158-003
5	1	ASSY BULKHEAD #6	23A01000-297
	1	BULKHEAD - MAIN	23A01158-197
	1	ANGLE – SIDE L.	23A01326-017
	1	ANGLE – SIDE R.	23A01326-016
	1	PANEL – SPR. BAR	21A01163-066
	1	SUPPORT – BULKHEAD LOWER	21A01158-177
	1	CLAMP – PUMP OUT TUBE	3A01158-003
6	1	ASSY BULKHEAD #7	21A01000-252
	1	BULKHEAD – MAIN	21A01158-189
	1	SUPPORT – BULKHEAD LOWER	21A01158-177
	1	GROMMET	MS35489-1A
7	1	ASSY BULKHEAD #8 L.	21A01000-267
	1	BULKHEAD - MAIN	21A01158-181
	1	SUPPORT – BULKHEAD LOWER	21A01158-187
	1	ASSY BULKHEAD #8 R	21A01000-266
	1	BULKHEAD - MAIN	21A01158-182
	1	SUPPORT – BULKHEAD LOWER	21A01158-188

**WIPLINE MODEL 2350 FLOAT PARTS MANUAL**

<b>FIGURE 1: HULL ASSEMBLY-AMPHIBIAN</b>			
<b>ITEM</b>	<b>QTY</b>	<b>PART DESCRIPTION</b>	<b>PART NO.</b>
8	1	ASSY BULKHEAD #9 L.	21A01000-263
	1	BULKHEAD - MAIN	21A01158-191
	1	SUPPORT – BULKHEAD LOWER	21A01158-193
	1	ANGLE – A.B. SKIN ATTACH L.	21A01158-179
	1	ANGLE – A.B. SKIN ATTACH R.	21A01158-180
	1	ASSY BULKHEAD #9 R	21A01000-264
	1	BULKHEAD - MAIN	21A01158-190
	1	SUPPORT – BULKHEAD LOWER	21A01158-192
	1	ANGLE – A.B. SKIN ATTACH L.	21A01158-179
	1	ANGLE – A.B. SKIN ATTACH R.	21A01158-180
9	1	ASS'Y – BULKHEAD #10	21A01000-262
	1	BULKHEAD - MAIN	21A01158-169
	1	ANGLE SIDE L.	21A01326-011
	1	ANGLE SIDE R.	21A01326-012
	1	PANEL – SPR. BAR	21A01163-066
	1	CLAMP, PUMP OUT TUBE	3A01158-003
	1		
10	1	BULKHEAD #11	21A01000-395
11	1	BULKHEAD #12	21A01000-396
12	1	BULKHEAD #13	21A01000-397
13	1	ASS'Y BULKHEAD #15	23A01000-298
	1	BULKHEAD - MAIN	23A01158-198
	1	CHANNEL – REIN.	21A01158-165
	1	PLATE – AFT.	21A08156-130
14	1	ASS'Y SPR. BAR PANEL FWD	23A01000-302
	1	PANEL – SPR. BAR	21A01163-065
	1	ANGLE – SIDE L.	23A01326-019
	1	ANGLE – SIDE R.	23A01326-018
	1	BOLT	AN4-5A
	1	WASHER	NAS1149F0463P
	1	NUT	MS21044N4

**WIPLINE MODEL 2350 FLOAT PARTS MANUAL**

<b>FIGURE 1: HULL ASSEMBLY-AMPHIBIAN</b>			
<b>ITEM</b>	<b>QTY</b>	<b>PART DESCRIPTION</b>	<b>PART NO.</b>
15	1	ASS'Y SPR. BAR PANEL AFT	21A01000-259
	1	PANEL – SPR. BAR	21A01163-065
	1	ANGLE – SIDE L.	21A01326-009
	1	ANGLE – SIDE R.	21A01326-010
	1	BOLT	AN4-5A
	1	WASHER	NAS1149F0463P
	1	NUT	MS21044N4
16	1	NOSE BUMPER	21A01000-295
17	1	STEP – BOARDING	3A01000-005
18	2	REINFORCEMENT – COVER	21A01156-126
19	2	COVER, SIDE ACCESS ASS'Y	21A01000-427
	2	COVER – INSP.	21A01004-101
	56	SCREW – ATTACH	AN526-632R6
	2	GASKET	21A01567-012
20	1	SIDE SKIN – STEP TO BOW L. OUTBR'D	23A01004-109
	1	SIDE SKIN – STEP TO BOW R. OUTBR'D	23A01004-108
	1	SIDE SKIN – STEP TO BOW L. INBR'D	23A01004-111
	1	SIDE SKIN – STEP TO BOW R. INBR'D	23A01004-110
	1	BRACKET (PADDLE)	3A01158-093
	1	PADDLE STOP	1002113
	1	CLIP (HOLDS PADDLE)	3A01503-001
	1	PADDLES	0238-0035
21	1	SIDE SKIN – STEP TO STERN L. OUTBR'D	23A01004-113
	1	SIDE SKIN – STEP TO STERN R. OUTBR'D	23A01004-112
	1	SIDE SKIN – STEP TO STERN L. INBR'D	23A01004-115
	1	SIDE SKIN – STEP TO STERN R. INBR'D	23A01004-114
		<i>NOTE: DIFFERENCE BETWEEN R. AND L. IS FINISH</i>	
22	2	STIFFENER – SIDE SKIN	23A01340-114
23	2	STIFFENER – SIDE SKIN	23A01340-115

**WIPLINE MODEL 2350 FLOAT PARTS MANUAL**

<b>FIGURE 1: HULL ASSEMBLY-AMPHIBIAN</b>			
<b>ITEM</b>	<b>QTY</b>	<b>PART DESCRIPTION</b>	<b>PART NO.</b>
24	2	STIFFENER – SIDE SKIN	23A01340-116
25	2	STIFFENER – SIDE SKIN	23A01340-117
26	2	STIFFENER – SIDE SKIN	23A01340-118
27	1	ASS'Y BOTTOM SKIN FWD L.	23A01000-327
	1	ASS'Y BOTTOM SKIN FWD R.	23A01000-328
		(INCLUDES BONDED STIFFENERS)	
	2	STIFFENER	21A01322-001
	2	STIFFENER	21A01322-002
	2	STIFFENER	21A01322-003
	2	STIFFENER	21A01322-004
	10	STIFFENER	21A01322-006
28	1	BOTTOM SKIN AFTERBODY L.	23A01004-121
	1	BOTTOM SKIN AFTERBODY R.	23A01004-120
29	1	ASS'Y SPRAY RAIL L.	21A01000-274
	1	ASS'Y SPRAY RAIL R.	21A01000-275
30	1	BOOSTER – SISTER KEEL L.	21A01000-429
	1	BOOSTER – SISTER KEEL R.	21A01000-428
31	1	DOUBLER – GUNWALL AFT L.	21A01162-033
32	1	DOUBLER – GUNWALL FWD L.	21A01162-031
	1	DOUBLER – GUNWALL FWD R.	21A01162-032
	1	DOUBLER – GUNWALL AFT R.	21A01162-034
33	2	TUBE – SPR. BAR MOUNTING	21A03115-001
	6	BOLT	AN4-22A
	12	WASHER	NAS1149D0416J
	12	WASHER	NAS1149D0463J
	6	NUT	MS21044N4

THIS PAGE INTENTIONALLY LEFT BLANK



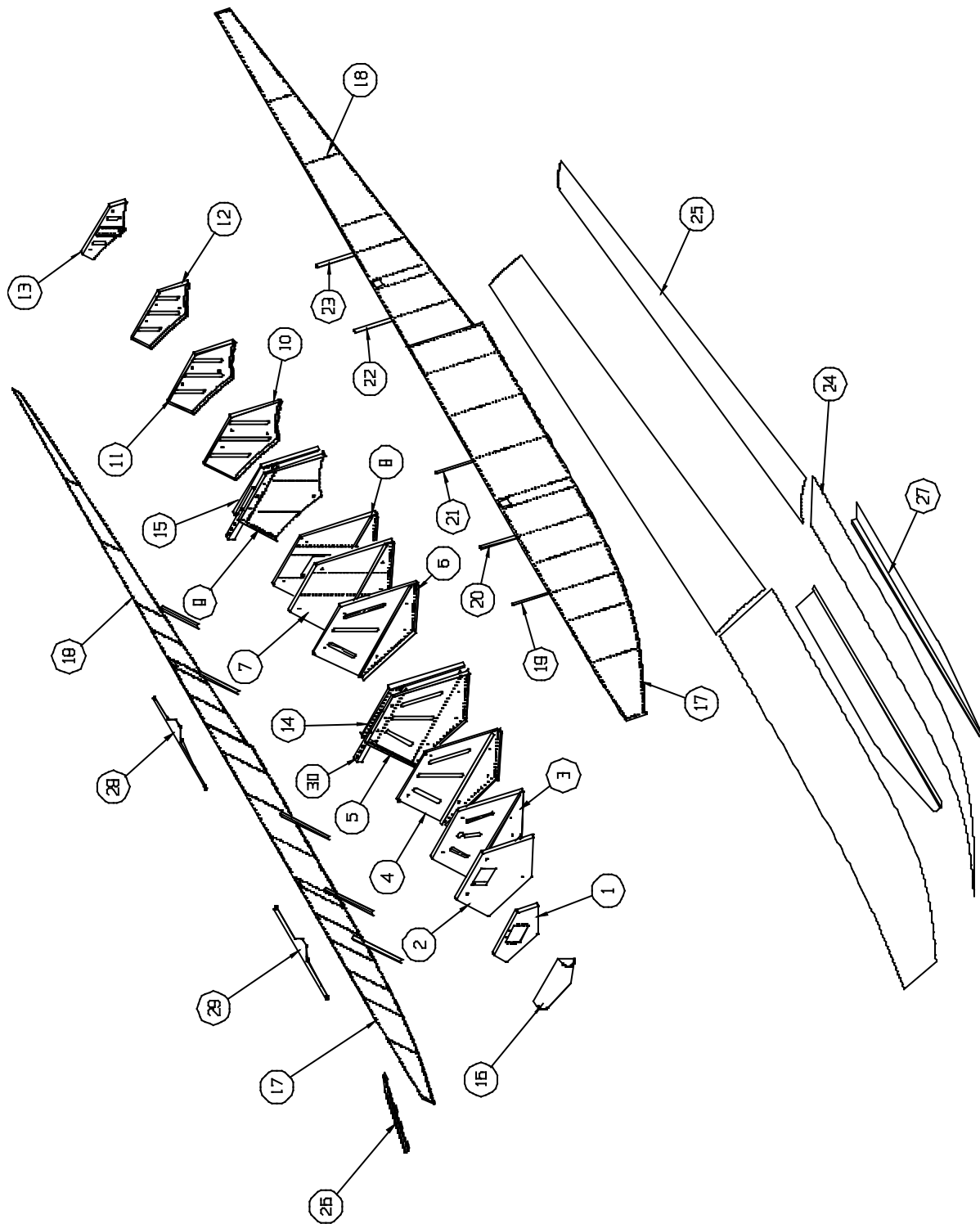

**HULL ASSEMBLY – SEAPLANE**  
**FIGURE 2**

**WIPLINE MODEL 2350 FLOAT PARTS MANUAL**

<b>ITEM</b>	<b>QTY</b>	<b>FIGURE 2: HULL ASSEMBLY-SEAPLANE PART DESCRIPTION</b>	<b>PART NO.</b>
1	1	BULKHEAD #1	21A01163-067
	1	COVER – NOSE GEAR OPENING	21S01150-134
	A/R	PLATE NUT	MS21059L3
2	1	ASSY BULKHEAD #3	21A01000-265
	1	BULKHEAD	21A01158-184
	1	ANGLE – NOSE BOX ATTACH	21A01326-006
	1	ANGLE – NOSE BOX ATTACH	21A01326-005
3	1	ASSY BULKHEAD #4	21A01000-261
	1	BULKHEAD – MAIN	21A01158-174
	1	SUPPORT – BULKHEAD LOWER	21A01158-175
	1	CLAMP PUMP OUT TUBE	3A01158-003
4	1	ASSY BULKHEAD #5	23A01000-296
	1	BULKHEAD – MAIN	23A01158-196
	1	SUPPORT – BULKHEAD LOWER	21A01158-175
	1	CLAMP PUMP OUT TUBE	3A01158-003
5	1	ASSY BULKHEAD #6	23A01000-297
	1	BULKHEAD - MAIN	23A01158-197
	1	ANGLE – SIDE L.	23A01326-017
	1	ANGLE – SIDE R.	23A01326-016
	1	PANEL – SPR. BAR	21A01163-066
	1	SUPPORT – BULKHEAD LOWER	21A01158-177
	1	CLAMP PUMP OUT TUBE	3A01158-003
6	1	ASSY BULKHEAD #7	21A01000-252
	1	BULKHEAD – MAIN	21A01158-189
	1	SUPPORT – BULKHEAD LOWER	21A01158-177
	1	GROMMET	MS35489-19
7	1	ASSY BULKHEAD #8	21S01000-308
	1	BULKHEAD - MAIN	21A01158-189
	1	SUPPORT – BULKHEAD LOWER	21A01158-177
	1	CLAMP PUMP OUT TUBE	3A01158-003
8	1	ASSY BULKHEAD #9	21S01000-309

**WIPLINE MODEL 2350 FLOAT PARTS MANUAL**

<b>ITEM</b>	<b>QTY</b>	<b>FIGURE 2: HULL ASSEMBLY-SEAPLANE PART DESCRIPTION</b>	<b>PART NO.</b>
	1	BULKHEAD – MAIN	21A01158-189
	1	SUPPORT – BULKHEAD LOWER	21A01158-177
	2	ANGLE – A.B. SKIN ATTACH	21A01158-203
	1	CLAMP PUMP OUT TUBE	3A01158-003
9	1	ASS'Y – BULKHEAD #10	21S01000-322
	1	BULKHEAD - MAIN	21A01158-169
	1	ANGLE SIDE L.	21A01326-011
	1	ANGLE SIDE R.	21A01326-012
	1	PANEL – SPR. BAR	21A01163-066
	2	ANGLE – VERTICAL	23A01340-129
	1	CLAMP PUMP OUT TUBE	3A01158-003
10	1	BULKHEAD #11	21A01000-395
11	1	BULKHEAD #12	21A01000-396
12	1	BULKHEAD #13	21A01000-397
13	1	ASS'Y BULKHEAD #15	23A01000-298
	1	BULKHEAD - MAIN	23A01158-198
	1	CHANNEL – REIN.	21A01158-165
	1	PLATE – AFT.	21A08156-130
14	1	ASS'Y SPR. BAR PANEL FWD	23A01000-302
	1	PANEL – SPR. BAR	21A01163-065
	1	ANGLE – SIDE L.	23A01326-019
	1	ANGLE – SIDE R.	23A01326-018
	1	BOLT	AN4-5A
	1	WASHER	NAS1149F0463P
	1	NUT	MS21044N4
15	1	ASS'Y SPR. BAR PANEL AFT	21A01000-259
	1	PANEL – SPR. BAR	21A01163-065
	1	ANGLE – SIDE L.	21A01326-009
	1	ANGLE – SIDE R.	21A01326-010
	1	BOLT	AN4-5A

**WIPLINE MODEL 2350 FLOAT PARTS MANUAL**

ITEM	QTY	FIGURE 2: HULL ASSEMBLY-SEAPLANE PART DESCRIPTION	PART NO.
	1	WASHER	NAS1149F0463P
	1	NUT	MS21044N4
16	1	NOSE BUMPER	21S01738-001
17	1	SIDE SKIN – STEP TO BOW L. OUTBR'D	23S01004-123
	1	SIDE SKIN – STEP TO BOW R. OUTBR'D	23S01004-122
	1	SIDE SKIN – STEP TO BOW L. INBR'D	23S01004-125
	1	SIDE SKIN – STEP TO BOW R. INBR'D	23S01004-124
	1	BRACKET (PADDLE)	3A01158-093
	1	PADDLE STOP	1002113
	1	CLIP (HOLDS PADDLE)	3A01503-001
	1	PADDLES	0238-0035
18	1	SIDE SKIN – STEP TO STERN L. OUTBR'D	23A01004-113
	1	SIDE SKIN – STEP TO STERN R. OUTBR'D	23A01004-112
	1	SIDE SKIN – STEP TO STERN L. INBR'D	23A01004-115
	1	SIDE SKIN – STEP TO STERN R. INBR'D	23A01004-114
		<u>NOTE:</u> DIFFERENCE BETWEEN R. AND L. IS FINISH	
19	2	STIFFENER – SIDE SKIN	23A01340-114
20	2	STIFFENER – SIDE SKIN	23A01340-115
21	2	STIFFENER – SIDE SKIN	23A01340-116
22	2	STIFFENER – SIDE SKIN	23A01340-117
23	2	STIFFENER – SIDE SKIN	23A01340-118
24	1	ASS'Y BOTTOM SKIN FWD L.	23A01000-327
	1	ASS'Y BOTTOM SKIN FWD R.	23A01000-328
		(INCLUDES BONDED STIFFENERS)	
	2	STIFFENER	21A01322-001
	2	STIFFENER	21A01322-002
	2	STIFFENER	21A01322-003
	2	STIFFENER	21A01322-004
	10	STIFFENER	21A01322-006

**WIPLINE MODEL 2350 FLOAT PARTS MANUAL**

<b>ITEM</b>	<b>QTY</b>	<b>FIGURE 2: HULL ASSEMBLY-SEAPLANE PART DESCRIPTION</b>	<b>PART NO.</b>
25	1	BOTTOM SKIN AFTERBODY L.	23S01004-133
	1	BOTTOM SKIN AFTERBODY R.	23S01004-132
26	1	ASS'Y SPRAY RAIL L.	21A01000-275
	1	ASS'Y SPRAY RAIL R.	21A01000-274
27	1	BOOSTER – SISTER KEEL L.	21A01000-429
	1	BOOSTER – SISTER KEEL R.	21A01000-428
28	1	DOUBLER – GUNWALL AFT L.	21A01162-033
	1	DOUBLER – GUNWALL AFT R.	21A01162-034
29	1	DOUBLER – GUNWALL FWD L.	21A01162-031
	1	DOUBLER – GUNWALL FWD R.	21A01162-032
30	2	TUBE – SPR. BAR MOUNTING	21A03115-001
	6	BOLT	AN4-22A
	12	WASHER	NAS1149D0416J
	12	WASHER	NAS1149D0463J
	6	NUT	MS21044N4

**THIS PAGE INTENTIONALLY LEFT BLANK**

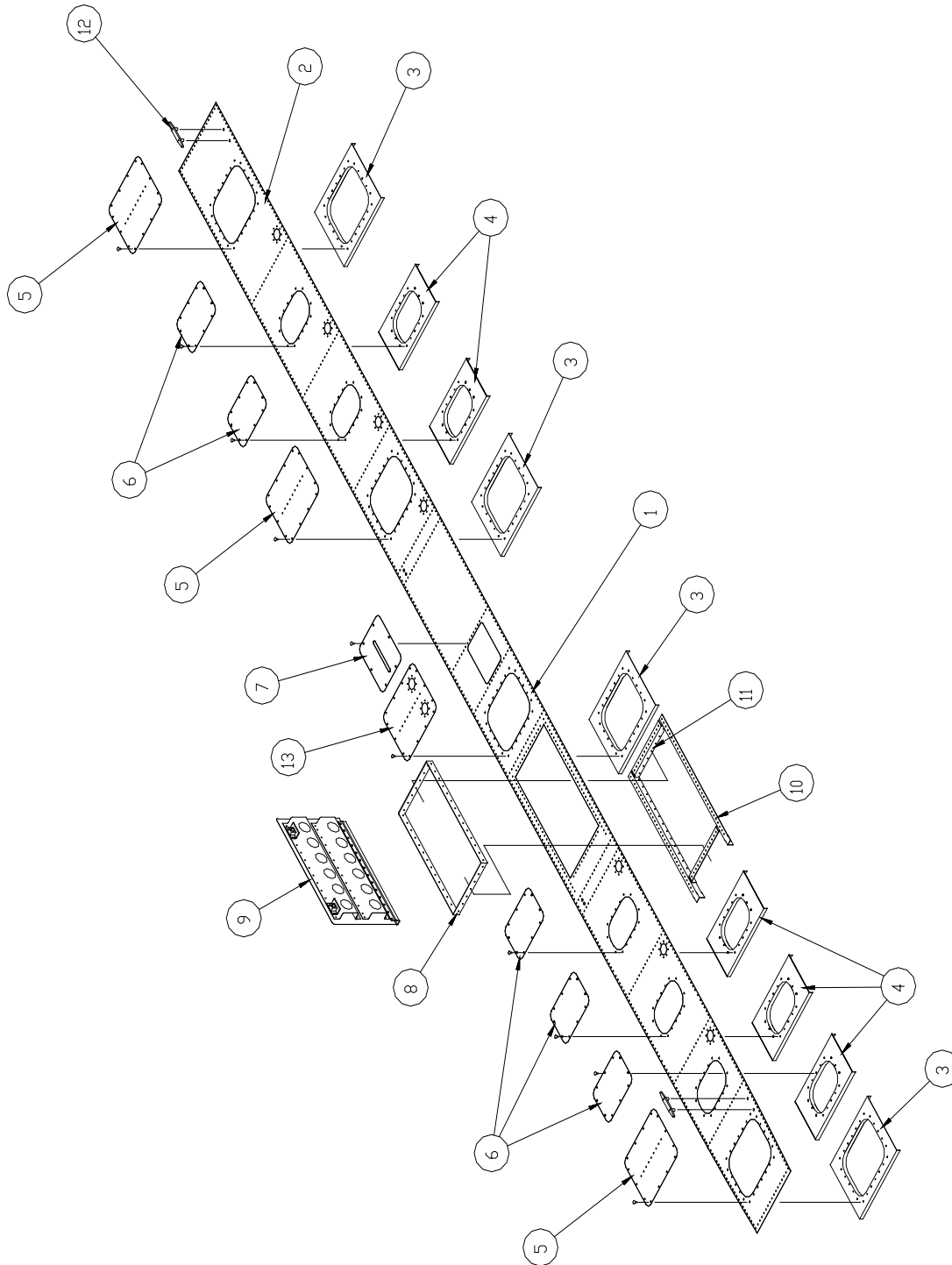

**TOP SKIN – HULL – AMPHIBIAN**  
**FIGURE 3**

**WIPLINE MODEL 2350 FLOAT PARTS MANUAL**

<b>ITEM</b>	<b>QTY</b>	<b>FIGURE 3: TOP SKIN – HULL – AMPHIBIAN PART DESCRIPTION</b>	<b>PART NO.</b>
1	1	SKIN – FWD SECTION L.	23A01004-117
	1	SKIN – FWD SECTION R.	23A01004-116
2	1	SKIN – AFT SECTION L.	23A01004-119
	1	SKIN – AFT SECTION R.	23A01004-118
3	4	SUPPORT – INSP. COVER – LARGE	21A01002-130
	A/R	NUT – TINNERMAN & INSULATOR	1002481
4	5	SUPPORT – INSP. COVER – SMALL	21A01002-131
	A/R	NUT – TINNERMAN & INSULATOR	1002481
		<i>(YEAR MANUFACTURED CHANGES COVER QUANTITIES)</i>	
5	4/3	INSP. COVER – LARGE – W/ ANGLE & GASKETS	21A01000-258
	A/R	SCREW – ATTACH	#8 X 5/8
	4/3	SEAL – GASKET ONLY	1001437
	4/3	SEAL – GASKET ONLY	21A01567-001
6	5	INSP. COVER – SMALL & GASKETS	21A01000-284
	A/R	SCREW – ATTACH	#8 X 5/8
	5	SEAL – GASKET ONLY	1001728
	5	SEAL – GASKET ONLY	21A01567-002
7	1	COVER – GEAR INDICATOR L.	21A01002-137
	1	COVER – GEAR INDICATOR R.	21A01002-138
	1	PLACARD – DOWN - LAND	10A3-6338-1
	1	PLACARD – UP - WATER	10A3-6338-2
	4	SCREW – CAM - LOK	2600-3
	2	SCREW – CAM – LOK	1126000-5
	6	RECEPTACLE – CAM – LOK	212-12
8	1	JAMB – BAGGAGE DOOR	21A01150-131
	1	JAMB – HINGE SIDE	1002067
9	1	ASSY – BAGGAGE DOOR	21A01000-268
	1	COVER - SKIN	21A01162-035
	1	HINGE	21A01741-004
	1	HINGE PIN	1002186
	2	STIFFENER - DOOR	21A01010-012
	2	STIFFENER ENDS	21A01004-106



**WIPLINE MODEL 2350 FLOAT PARTS MANUAL**

<b>ITEM</b>	<b>QTY</b>	<b>FIGURE 3: TOP SKIN – HULL – AMPHIBIAN PART DESCRIPTION</b>	<b>PART NO.</b>
	2	RETAINER - LOCK	3A01206-001
	2	LOCK PIN	3A01273-004
	2	CATCH – LATCH	3A01702-004
	2	LOCK SPRING	3A01525-003
	2	RING – OPENING	1002663
	1	SEAL – GASKET (NOT SHOWN) BAGGAGE HUTCH	1001438
	12	POP RIVET	01692-0410
	2	BOLT	10/32 X ½ SS
10	1	TOP RAIL – BAGGAGE OPENING L.	21A01326-003
	1	TOP RAIL – BAGGAGE OPENING R.	21A01326-002
11	2	JAMB – BAGGAGE DOOR	21A01326-004
12	2	CLEAT – TIE DOWN	21A01203-001
	4	BUSHING	21A01280-004
	4	SCREW – ATTACH	AN525-10R24
13	1	INSP. COVER – LARGE – W/ ANGLE (2 CUPS) & GASKETS	21A01000-273
	A/R	SCREW – ATTACH	#8 X 5/8
	1	SEAL – GASKET ONLY	1001437

THIS PAGE INTENTIONALLY LEFT BLANK

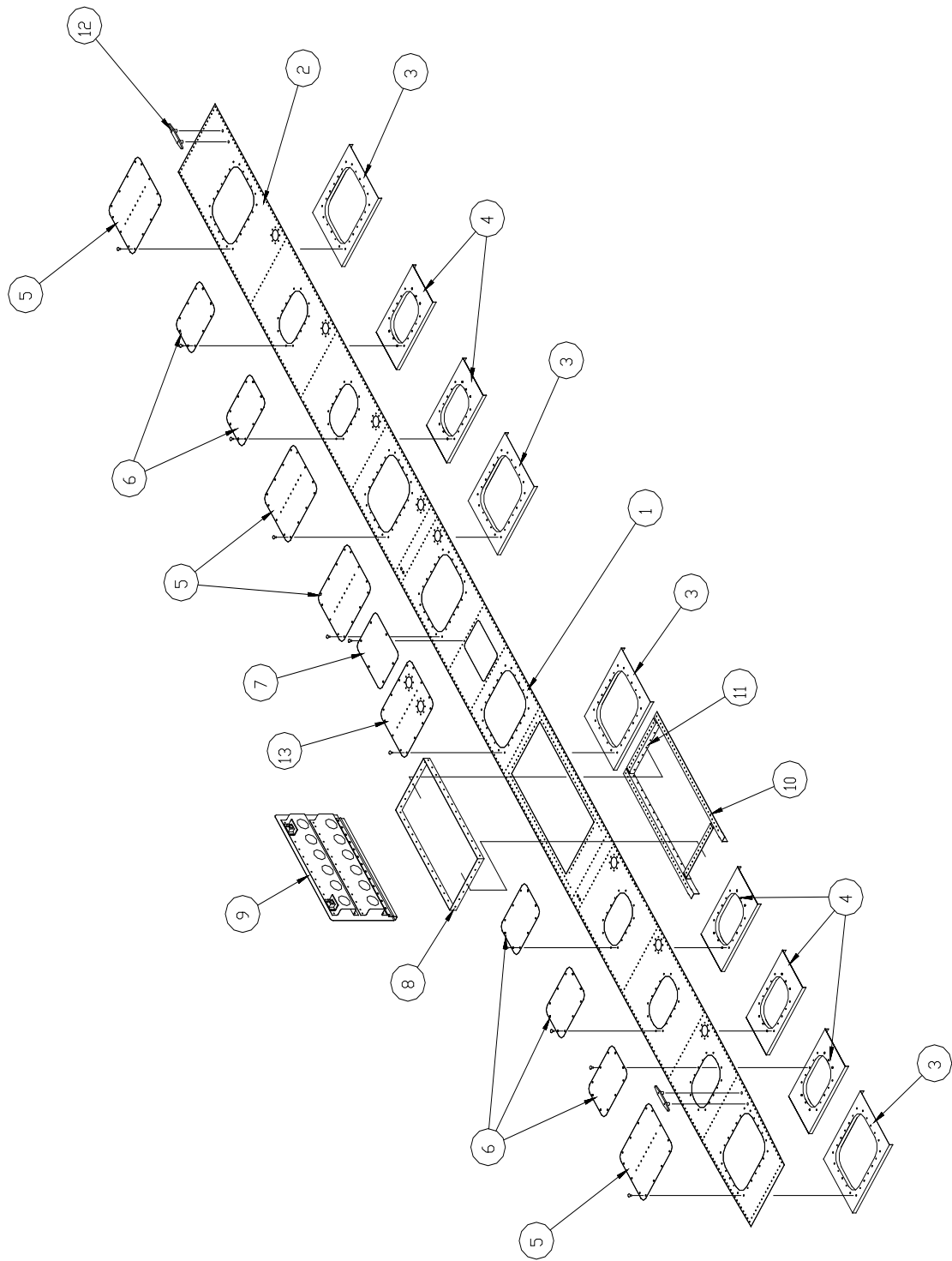

**TOP SKIN – HULL – SEAPLANE**  
**FIGURE 4**

**WIPLINE MODEL 2350 FLOAT PARTS MANUAL**

<b>ITEM</b>	<b>QTY</b>	<b>FIGURE 4: TOP SKIN – HULL – SEAPLANE PART DESCRIPTION</b>	<b>PART NO.</b>
1	1	SKIN – FWD SECTION L.	23S01004-139
	1	SKIN – FWD SECTION R.	23S01004-138
2	1	SKIN – AFT SECTION L.	23S01004-141
	1	SKIN – AFT SECTION R.	23S01004-140
3	5	SUPPORT – INSP. COVER - LARGE	21A01002-130
	A/R	NUT – TINNERMAN & INSULATOR	1002481
4	5	SUPPORT – INSP. COVER – SMALL	21A01002-131
	A/R	NUT – TINNERMAN & INSULATOR	1002481
5	5	INSP. COVER – LARGE – W/ ANGLE & GASKETS	21A01000-258
	A/R	SCREW – ATTACH	#8 X 5/8
	5	SEAL – GASKET ONLY	1001437
	5	SEAL – GASKET	21A01567-001
6	5	INSP. COVER – SMALL & GASKETS	21A01000-284
	A/R	SCREW – ATTACH	#8 X 5/8
	5	SEAL – GASKET ONLY	1001728
	5	SEAL – GASKET	21A01567-002
7	1	COVER W/ GASKET	21S01000-399
	1	SEAL – GASKET	21S01567-013
	A/R	SCREW – ATTACH	#8 X 5/8
	A/R	NUT – TINNERMAN & INSULATOR	1002481
	2	STIFFENER – ANGLE	30S01326-035
8	1	JAMB – BAGGAGE DOOR	21A01150-131
	1	JAMB – BAGGAGE DOOR, HINGE SIDE	1002067
9	1	ASSY – BAGGAGE DOOR	21A01000-268
	1	COVER – SKIN	21A01162-035
	1	HINGE	21A01741-004
	2	STIFFENER – DOOR	21A01010-012
	1	HINGE PIN	1002186
	2	STIFFENER ENDS	21A01004-106
	2	RETAINER – LOCK	3A01206-004

**WIPLINE MODEL 2350 FLOAT PARTS MANUAL**

<b>ITEM</b>	<b>QTY</b>	<b>FIGURE 4: TOP SKIN – HULL – SEAPLANE PART DESCRIPTION</b>	<b>PART NO.</b>
	2	LOCK PIN	3A01273-004
	2	CATCH – LATCH	3A01702-001
	2	LOCK SPRING	3A01525-003
	2	RING – OPENING	1002663
	1	SEAL – GASKET (NOT SHOWN)	1001438
	12	POP RIVET	01692-0410
	2	BOLT	10/32 X ½ SS
10	1	TOP RAIL – BAGGAGE OPENING L.	21A01326-003
	1	TOP RAIL – BAGGAGE OPENING R.	21A01326-002
11	1	JAMB – BAGGAGE DOOR	21A01326-004
12	2	CLEAT – TIE DOWN	21A01203-001
	4	BUSHING	21A01280-004
	4	SCREW – ATTACH	AN525-10R24
13	1	INSP. COVER – LARGE – W/ ANGLE (2 CUPS) & GASKETS	21A01000-273
	A/R	SCREW – ATTACH	#8 X 5/8
	1	SEAL – GASKET ONLY	1001437

**SECTION 2: WHEEL WELL ASSEMBLY - AMPHIBIAN**

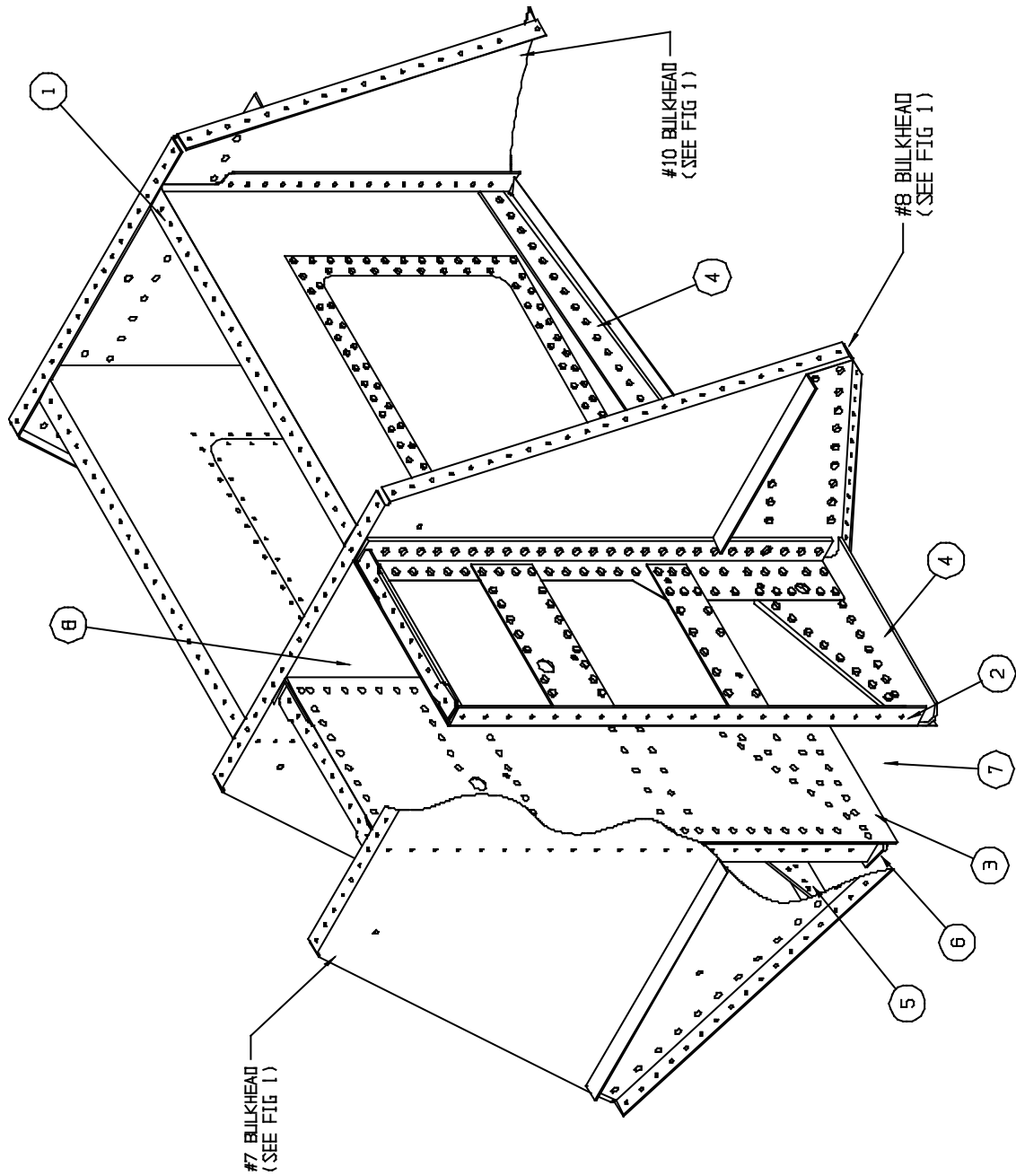

**WHEEL WELL ASSEMBLY – AMPHIBIAN**  
**FIGURE 5**

**WIPLINE MODEL 2350 FLOAT PARTS MANUAL**

<b>ITEM</b>	<b>QTY</b>	<b>FIGURE 5: WHEEL WELL ASSEMBLY - AMPHIBIAN PART DESCRIPTION</b>	<b>PART NO.</b>
1	1	ASS'Y – WHEELWELL HALF L.	21A01000-289
	1	PANEL – FORMED L.	21A01158-185
	1	RING – COVER REINFORCEMENT	13A01156-124
	1	COVER	21A01158-163
	28	SCREW	AN526-632R6
	1	ASS'Y – WHEELWELL HALF R.	21A01000-290
	1	PANEL – FORMED R.	21A01158-186
	1	RING – COVER REINFORCEMENT	13A01156-124
	1	COVER	21A01158-163
	28	SCREW	AN526-632R6
2	1	ASS'Y – WHEELWELL PANEL – OUTBR'D L.	21A01000-257
	1	ASS'Y - WHEELWELL PANEL – OUTBR'D R.	21A01000-256
3	1	ASS'Y – WHEELWELL PANEL – INBR'D L.	21A01000-255
	1	ASS'Y - WHEELWELL PANEL – INBR'D R.	21A01000-254
4	1	CARRY-THRU STRAP OUTBR'D L.	21A01017-005
	1	CARRY-THRU STRAP OUTBR'D R.	21A01017-004
5	1	CARRY-THRU STRAP INBR'D L.	21A01017-003
	1	CARRY-THRU STRAP INBR'D R.	21A01017-002
6	1	CARRY-THRU STRAP INBR'D L.	21A01017-007
	1	CARRY-THRU STRAP INBR'D R.	21A01017-006
	1	ANGLE – ATTACH AFT L.	21A01156-131
	1	ANGLE – ATTACH AFT R.	21A01156-132
	1	SHIM	21A01156-125
	2	ANGLE – ATTACH FWD	21A01326-015
7	1	SAND GUARD (NOT SHOWN)	21A01150-136
	4	SCREW	AN526-1032R8
	1	SAND GUARD ASS'Y	21A01000-398
	4	NUT PLATE	MS21078-3
8	1	MUD FLAP (NOT SHOWN)	21A01569-001
	1	REINFORCEMENT	21A01150-135



**THIS PAGE INTENTIONALLY LEFT BLANK**

**SECTION 3: HULL EXTRUSIONS - AMPHIBIAN AND STRAIGHT**

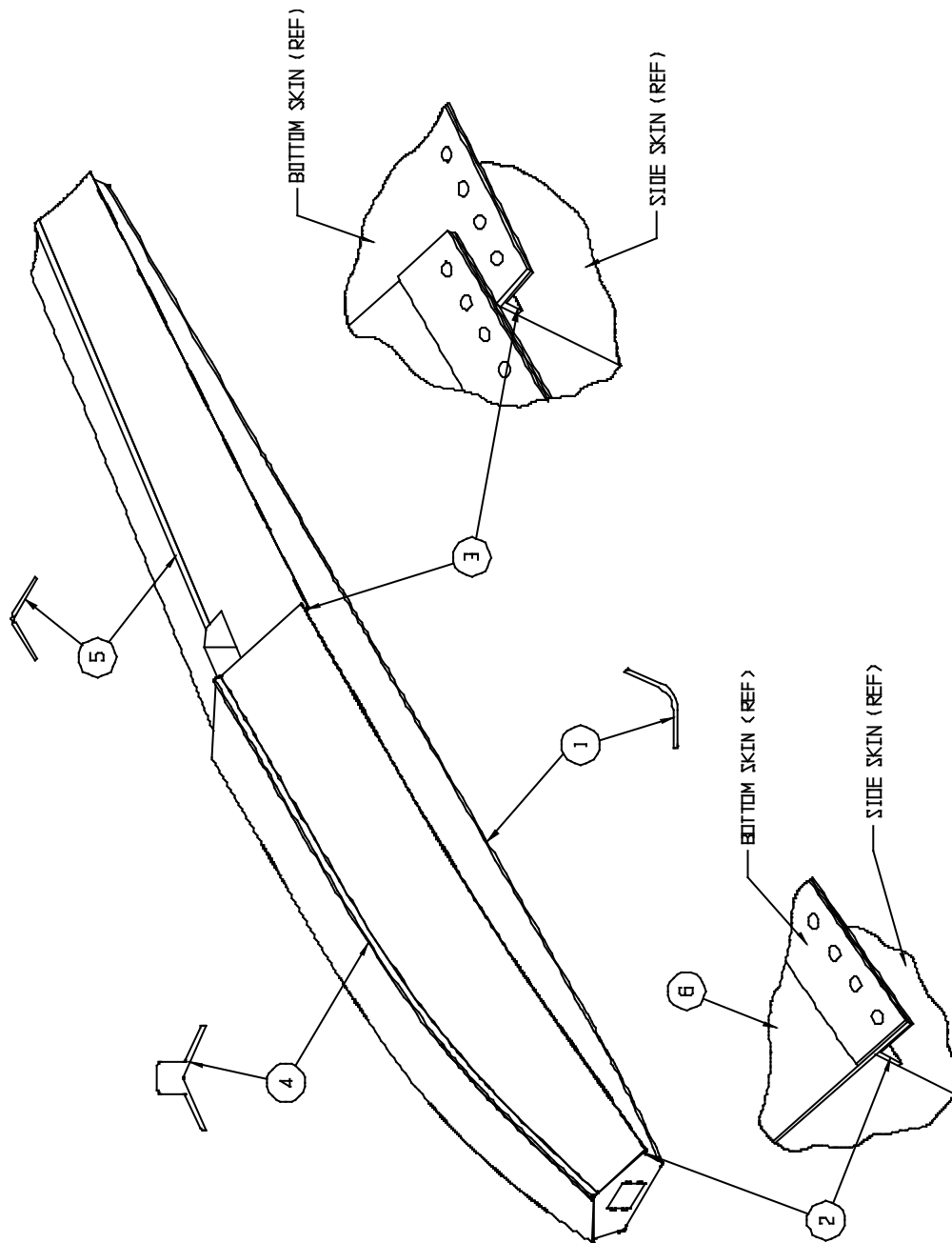

**EXTRUSIONS – HULL – AMPHIBIAN**  
**FIGURE 6**

**WIPLINE MODEL 2350 FLOAT PARTS MANUAL**

<b>ITEM</b>	<b>QTY</b>	<b>FIGURE 6: EXTRUSIONS – HULL - AMPHIBIAN PART DESCRIPTION</b>	<b>PART NO.</b>
1	1	GUNWALL – L.	23A01324-003
	1	GUNWALL – R.	23A01324-004
2	1	CHINE - FWD L.	23A01340-013
	1	CHINE – FWD R.	23A01340-012
3	1	CHINE – AFTERBODY L.	23A01340-011
	1	CHINE – AFTERBODY R.	23A01340-010
4	1	KEEL - MAIN	23A01321-002
5	1	KEEL - AFTERBODY	23A01008-170
6	1	STRAP – CHINE L.	23A01005-295
	1	STRAP – CHINE R.	23A01005-296

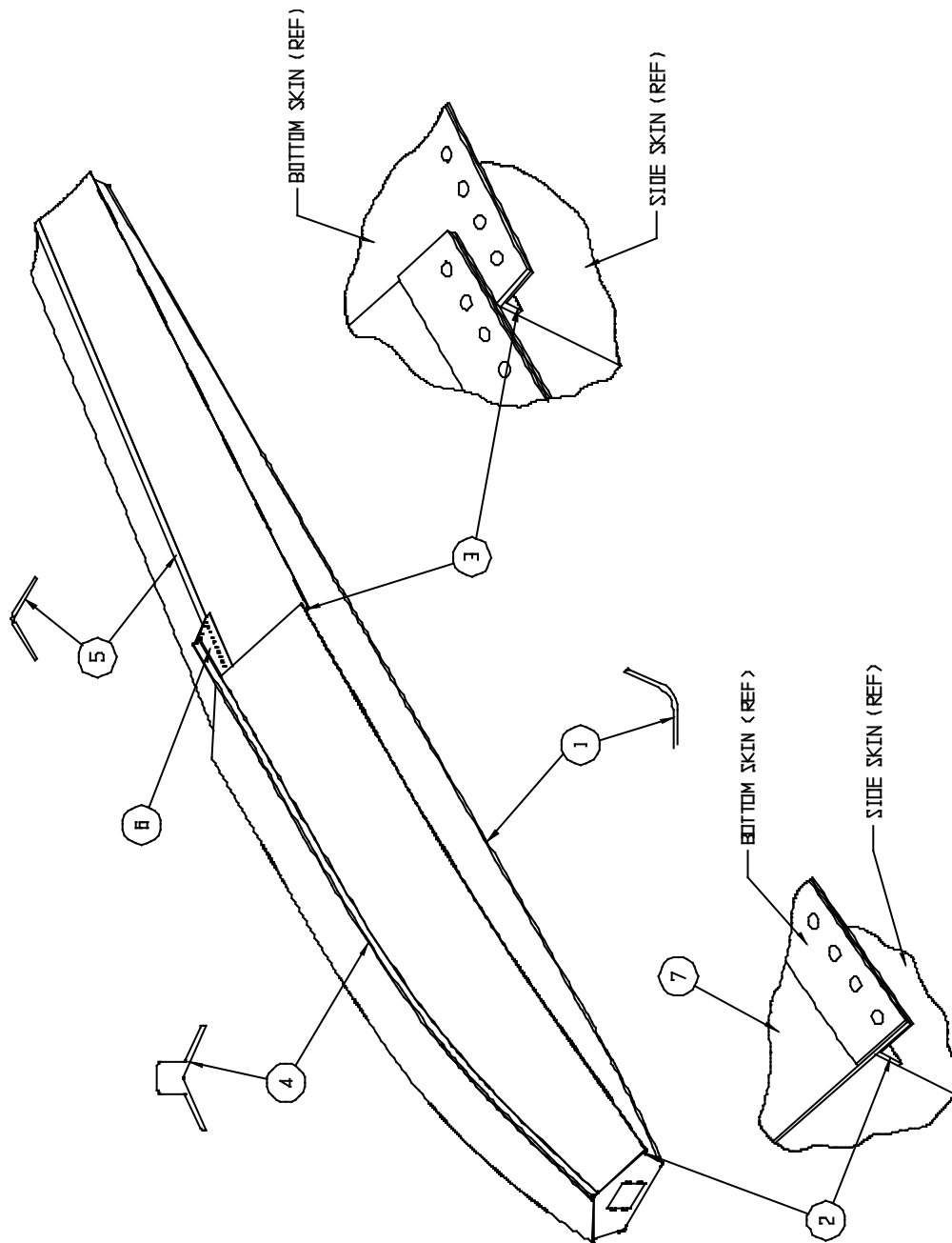

**EXTRUSIONS – HULL – SEAPLANE**  
FIGURE 7

**WIPLINE MODEL 2350 FLOAT PARTS MANUAL**

<b>ITEM</b>	<b>QTY</b>	<b>FIGURE 7: EXTRUSIONS – HULL - SEAPLANE PART DESCRIPTION</b>	<b>PART NO.</b>
1	1	GUNWALL – L.	23A01324-003
	1	GUNWALL – R.	23A01324-004
2	1	CHINE - FWD L.	23A01340-013
	1	CHINE – FWD R.	23A01340-012
3	1	CHINE – AFTERBODY L.	23A01340-011
	1	CHINE – AFTERBODY R.	23A01340-010
4	1	KEEL - MAIN	23S01321-003
5	1	KEEL - AFTERBODY	23S01008-173
6	1	ANGLE SUPPORT – AFTERBODY L.	21S01163-037
	1	ANGLE SUPPORT – AFTERBODY R.	21S01163-038
7	1	STRAP - CHINE L.	23A01005-295
	1	STRAP – CHINE R.	23A01005-296

THIS PAGE INTENTIONALLY LEFT BLANK

**SECTION 4: PUMPER TUBE INSTALLATION**



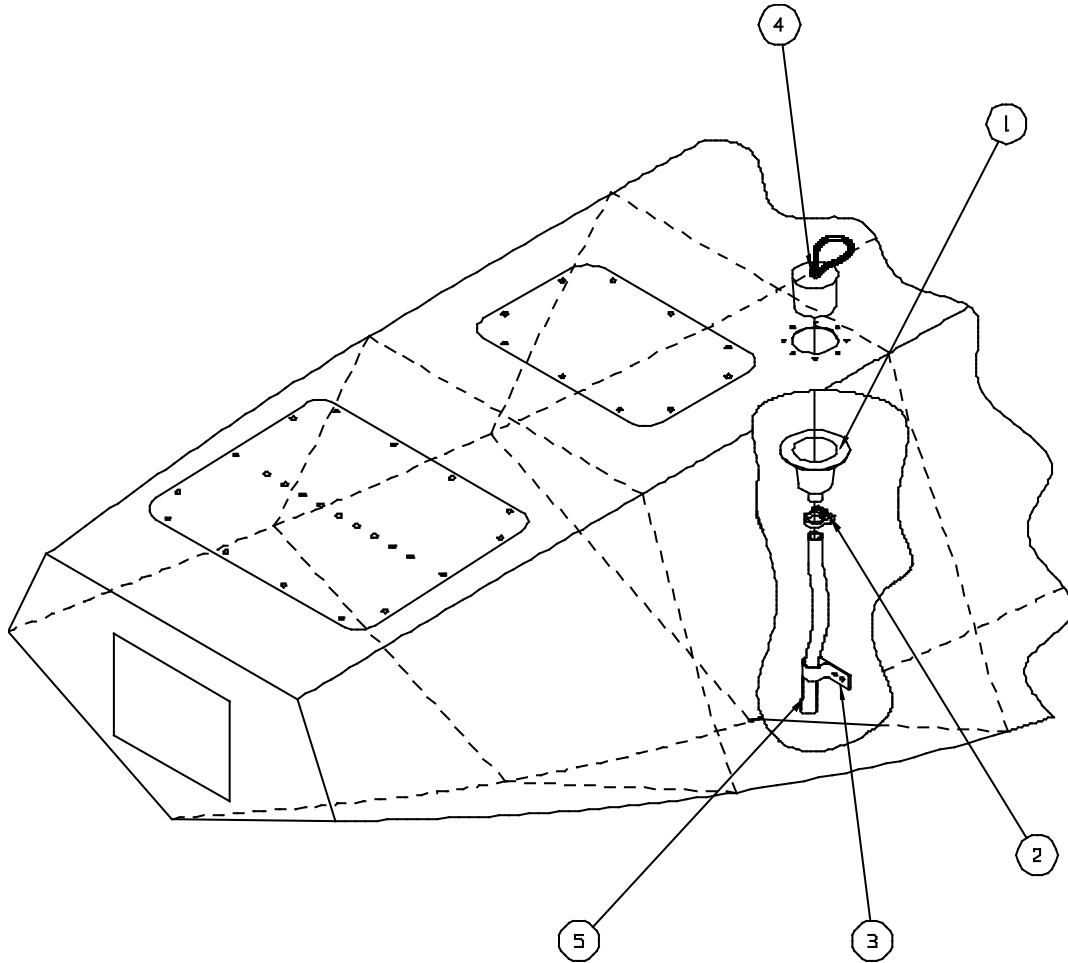

**PUMPER TUBE INSTALLATION**  
**FIGURE 8**

**WIPLINE MODEL 2350 FLOAT PARTS MANUAL**

<b>ITEM</b>	<b>QTY</b>	<b>FIGURE 8: PUMPER TUBE INSTALLATION PART DESCRIPTION</b>	<b>PART NO.</b>
1	1	CUP – PUMPOUT ALUM.	4A01749-001
	A/R	RIVETS	MS20470AD4-4
2	1	CLAMP – UPPER END	57134
3	1	CLAMP – LOWER END	3A01158-003
4	1	STOPPER – PUMPER TUBE	2111
5	1	PUMPOUT TUBE 10.5 IN.	21A01618-062
	1	PUMPOUT TUBE 12.5 IN.	21A01618-061
	1	PUMPOUT TUBE 15.0 IN.	21A01618-060
	1	PUMPOUT TUBE 17.5 IN.	21A01618-059
	1	PUMPOUT TUBE 23.0 IN.	21A01618-058
	1	PUMPOUT TUBE 21.5 IN.	21A01618-056
	1	PUMPOUT TUBE 18.5 IN.	21A01618-055

THIS PAGE INTENTIONALLY LEFT BLANK

**SECTION 5: WATER RUDDER INSTALLATION**

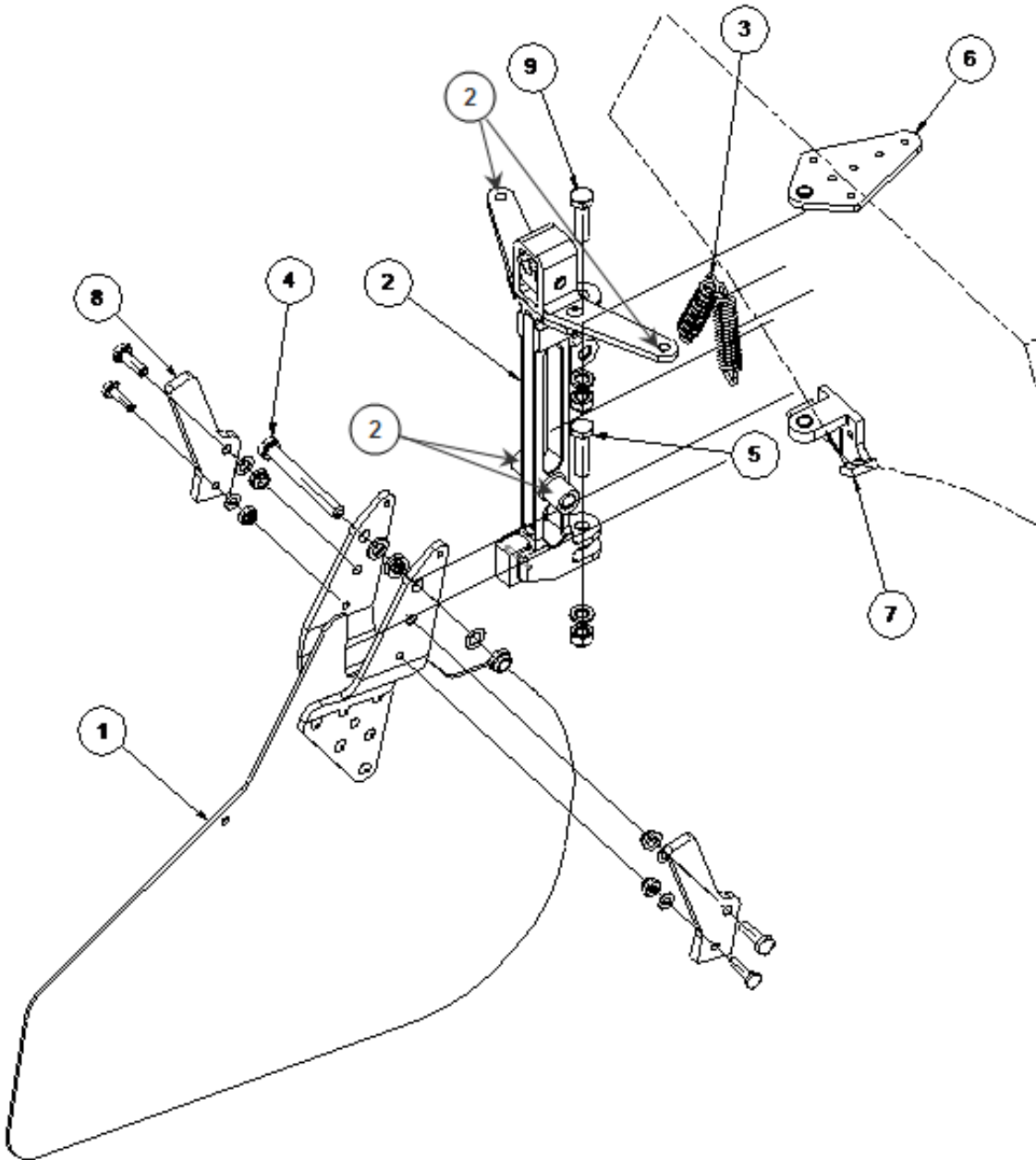

**INSTALLATION WATER RUDDER**  
FIGURE 9

**WIPLINE MODEL 2350 FLOAT PARTS MANUAL**

<b>ITEM</b>	<b>QTY</b>	<b>FIGURE 9: WATER RUDDER INSTALLATION PART DESCRIPTION</b>	<b>PART NO.</b>
1	1	ASS'Y., BLADE	21A08000-123
	1	BLADE	1002649
	1	ARM, L.	21A08019-001
	1	ARM, R.	21A08019-002
2	1	WATER RUDDER POST WITH BELLCRANK ASSEMBLY	1003858
	1	WATER RUDDER POST ASSEMBLY	1003854
	1	WATER RUDDER POST	1003267
	2	BUSHING	05DU06
	1	BELLCRANK, WATER RUDDER POST ASSEMBLY	1003853
	1	BELLCRANK, WATER RUDDER POST	1003274
	2	BUSHING	03DU04
	1	BUMPER, DOWN STOP	21A08648-002
	1	ROLL PIN	1001457
	1	GUIDE, RETRACT	21A8602-009
	1	PIN ATTACH	5/16 x 1 ½ inches
3	2	SPRING	21A08525-006
4	1	BOLT, ATTACH	AN5-25A
	3	WASHER	NAS1149D0516J
	1	WASHER	NAS 1149D0563J
	1	NUT	MS21083N5
5	1	BOLT, ATTACH	AN5-11A
	A/R	WASHER	NAS1149D0563J
	1	NUT	MS21044N5

**WIPLINE MODEL 2350 FLOAT PARTS MANUAL**

<b>FIGURE 9: WATER RUDDER INSTALLATION</b>			
<b>ITEM</b>	<b>QTY</b>	<b>PART DESCRIPTION</b>	<b>PART NO.</b>
6	1	ASS'Y., TOP BEARING	21A01000-299
	1	PLATE	21A01019-003
	1	BEARING	21A01705-003
7	1	ASS'Y., LOWER BEARING	21A08000-157
	1	BRACKET	21A08318-002
	1	BEARING	05DU06
8	2	STOP	21A08154-009
	2	BOLT, ATTACH, LWR.	AN4-6A
	2	WASHER	NAS1149D0416J
	2	NUT	MS21083N4
	2	BOLT, ATTACH, LWR.	AN3-6A
	2	WASHER	NAS1149D0316J
	2	NUT	MS21044N3
9	1	BOLT, ATTACH	AN5-12A
	A/R	WASHER	NAS1149D0563J
	1	NUT	MS21044N5

**SECTION 6: NOSE GEAR ASSEMBLY**



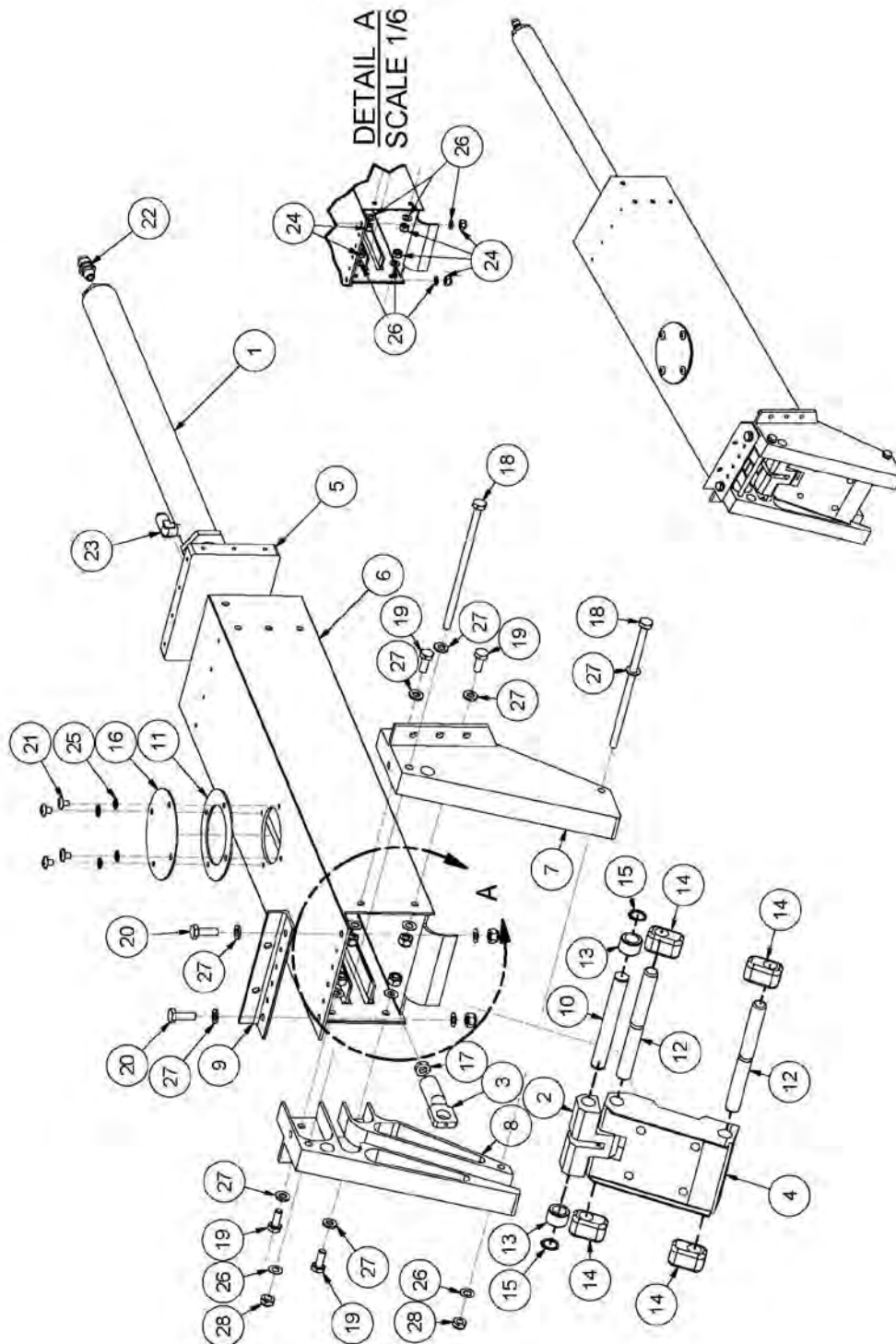

**ASSEMBLY – NOSE GEAR RETRACTION**  
**FIGURE 10**

**WIPLINE MODEL 2350 FLOAT PARTS MANUAL**

<b>FIGURE 10: NOSE GEAR RETRACTION ASS'Y.</b>			
<b>ITEM</b>	<b>QTY</b>	<b>PART DESCRIPTION</b>	<b>PART NO.</b>
1	1	CYLINDER, NOSE GEAR, 2100/2350	1002571
2	1	LINK - TROLLEY, NOSE GEAR	21A07032-005
3	1	END - ROD, CYLINDER, NOSE GEAR	21A07094-002
4	1	TROLLEY - NOSE GEAR	21A07187-009
5	1	END CAP, NOSE BOX	21A07237-002
6	1	BOX, NOSE GEAR	21A07323-001
7	1	END, NOSE GEAR TRACK LEFT	21A07349-003
8	1	END, NOSE GEAR TRACK, RIGHT	21A07349-004
9	1	EXTRUSION, ANGLE	21A07359-194
10	1	AXLE, TROLLEY LINK	21A07509-007
11	1	GASKET, COVER, NOSE BOX, 2100 AND 3000	30A07567-011
12	2	AXLE, TROLLEY	34A07509-008
13	2	BEARING - TROLLEY, NOSE GEAR	3A07530-001
14	4	BLOCK, SLIDE, TROLLEY, NOSE GEAR	3A07604-001
15	2	SNAP RING	5100-46-H
16	1	COVER, BULKHEAD HYD CYL. HOLE	8A01008-080
17	1	NUT	AN316-5R
18	2	BOLT	AN4-53A
19	4	BOLT	AN4-5A
20	2	BOLT	AN4-6A
21	4	SCREW, MACHINE, TRUSS HEAD	AN526-1032R4
22	1	NIPPLE, FLARED TUBE AND PIPE THREAD	AN816-4D
23	1	ELBOW	MS20822-4D
24	6	NUT	MS21044N4
25	4	STAR WASHER	MS35333-39
26	8	WASHER	NAS1149D0416J
27	8	WASHER	NAS1149D0463J
28	2	KAYNAR NUT	NAS679-A4W

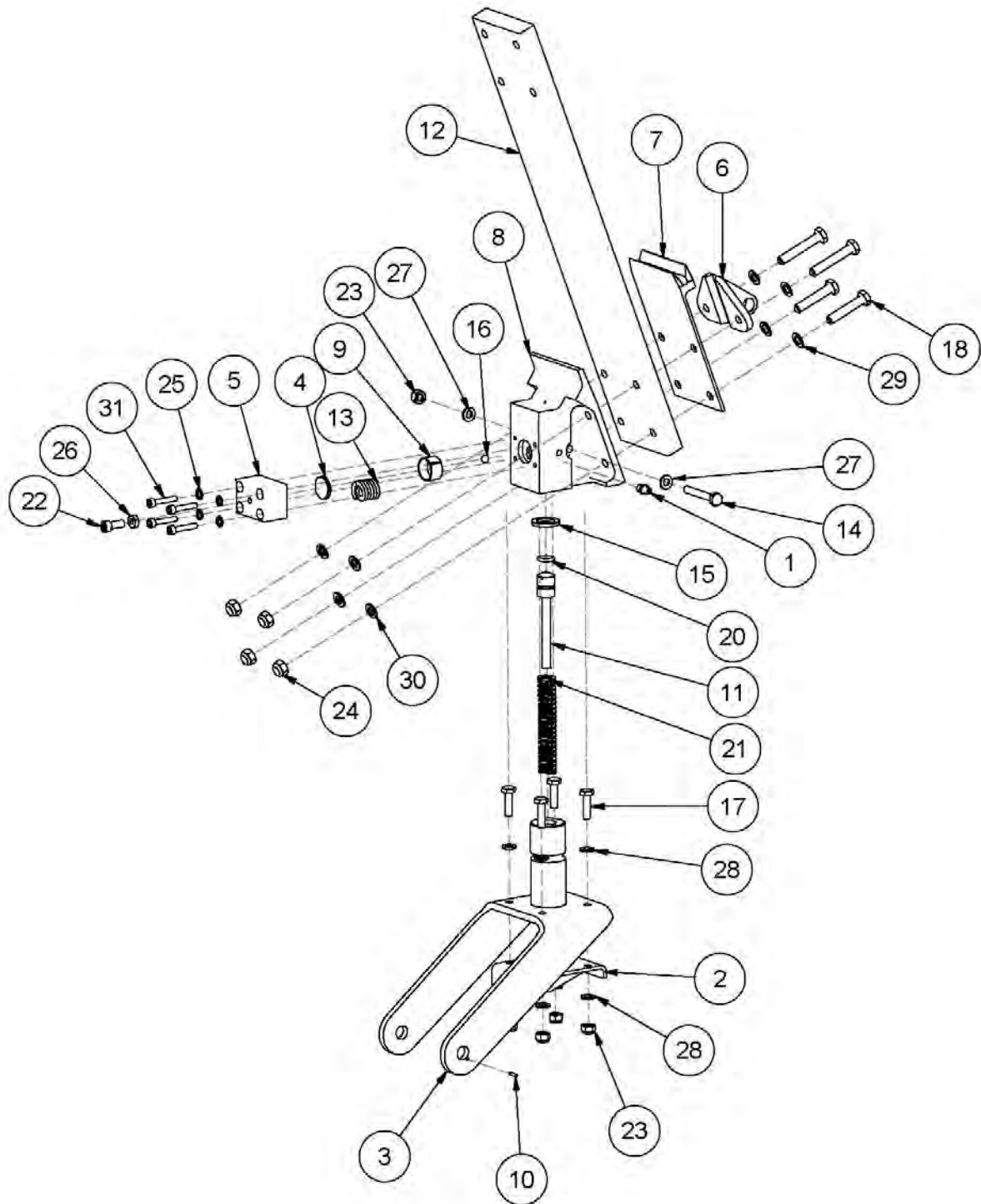

**ASSEMBLY – NOSE GEAR – LOWER**  
FIGURE 11

**WIPLINE MODEL 2350 FLOAT PARTS MANUAL**

<b>ITEM</b>	<b>QTY</b>	<b>FIGURE 11: ASSEMBLY – NOSE GEAR - LOWER PART DESCRIPTION</b>	<b>PART NO.</b>
1	1	COMMON GREASEZERK	1095K41
2	1	WELDMENT, PIVOT SHAFT, FORK, NOSE GEAR	21A06000-020
3	1	FORK, NOSE GEAR (2100)	21A06020-001
4	1	PRESSURE PLATE	21A06160-053
5	1	BLOCK - SPRING	21A06194-005
6	1	TOW HOOK NOSE GEAR	21A06213-006
7	1	BEARING PLATE, LOWER, NOSE GEAR	21A06237-001
8	1	BLOCK - PIVOT, NOSE GEAR	21A06318-005
9	1	FRICTION CUP	21A06475-006
10	1	PIN, ANTIROTATION	21A06476-003
11	1	PLUNGER- NOSE WHEEL, 21,23,3,34	21A06605-002
12	1	SPRING NOSE GEAR	21A06653-001
13	1	PRESSURE SPRING	21A06705-005
14	1	BOLT - MODIFIED, PIVOT BLOCK	30A06702-016
15	1	THRUST WASHER	3A06602-001
16	1	1/4" CHROME BALL BEARING	9528K15
17	4	BOLT	AN4-7A
18	2	BOLT	AN5-14A
19	2	BOLT	AN5-16A
20	1	O-RING	AN6227-9
21	1	SPRING	M62-350
22	1	SOCKET HEAD CAP SCREW	MS16997-60
23	5	NUT	MS21044N4
24	4	NUT	MS21044N5
25	4	STAR WASHER	MS35333-39
26	1	NUT	MS35649-2252
27	2	WASHER	NAS1149D0463J
28	8	WASHER	NAS1149F0463P
29	4	WASHER	NAS1149F0532P
30	4	WASHER	NAS1149F0563P
31	4	SOCKET HEAD CAP SCREW	NAS1352-316P

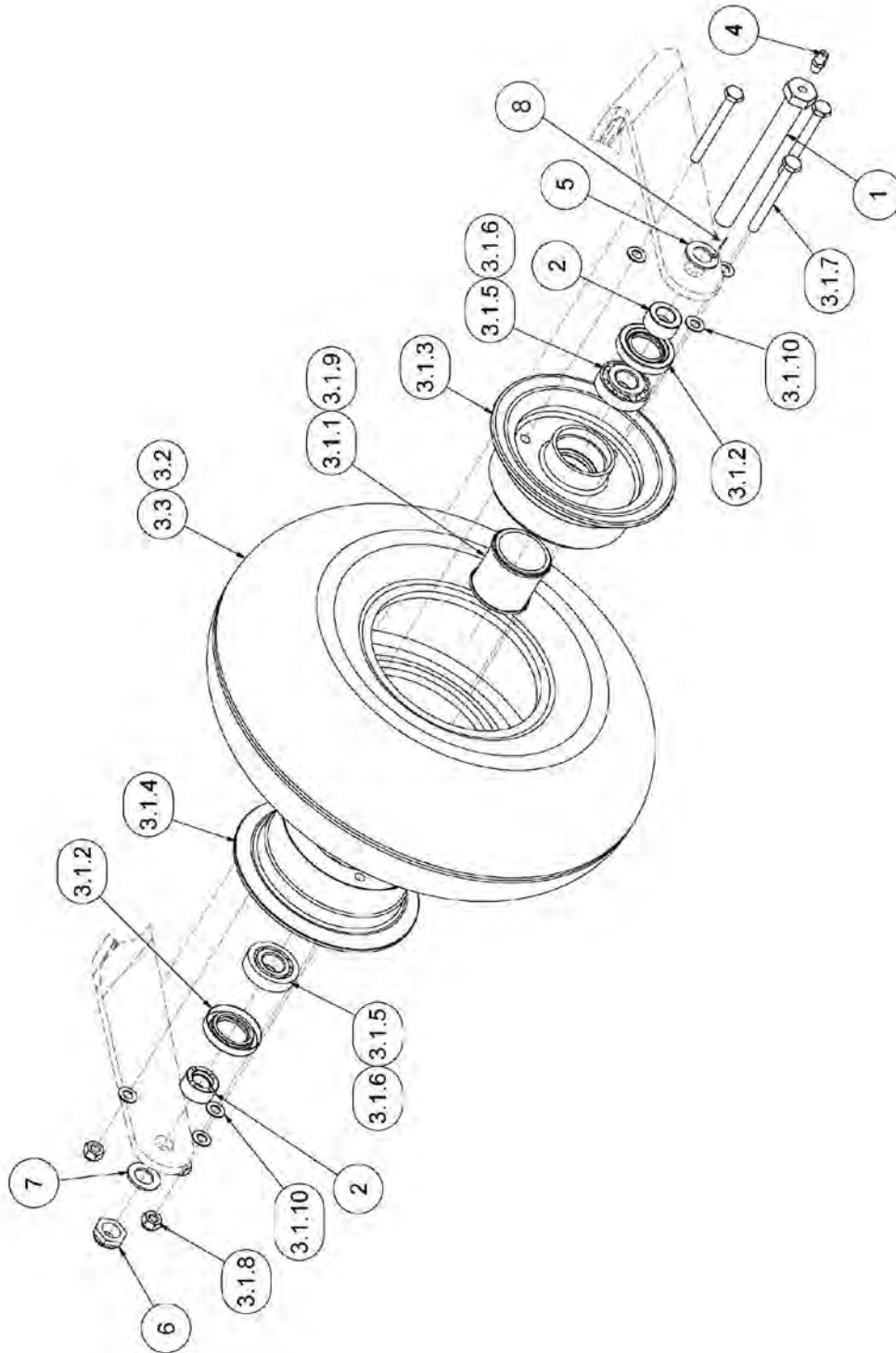

**ASSEMBLY – NOSE WHEEL (GROVE)**  
FIGURE 12A

**WIPLINE MODEL 2350 FLOAT PARTS MANUAL**

<b>FIGURE 12A: NOSE WHEEL ASS'Y - GROVE</b>			
<b>ITEM</b>	<b>QTY</b>	<b>PART DESCRIPTION</b>	<b>PART NO.</b>
1	1	BOLT, AXLE, NOSE GEAR	1005927
2	2	SPACER	1005929
3	1	ASSEMBLY, NOSE WHEEL	1005931
3.1	1	ASSEMBLY, WHEEL, GROVE	49-12AF-001
3.1.1	1	GREASE RETAINER	010-019
3.1.2	2	SEAL	010-026
3.1.3	1	WHEEL HALF INNER	015-020A
3.1.4	1	WHEEL HALF OUTER	016-020AF
3.1.5	2	BEARING CORE	A4050
3.1.6	2	BEARING CONE	A4138
3.1.7	3	BOLT	AN4-23A
3.1.8	3	NUT	MS21044N-4
3.1.9	2	O-RING	MS28775-029
3.1.10	6	WASHER	NAS1149F0416
3.2	1	TIRE	XA1AA
3.3	1	TUBE	AD1A2
4	1	COMMON GREASE ZERK	1095K41
5	1	MODIFIED WASHER	3A06702-003
6	1	NUT	MS21083N8
7	1	WASHER	NAS1149D0863J
8	1	PIN ANTI ROTATE AXEL	21A06476-003

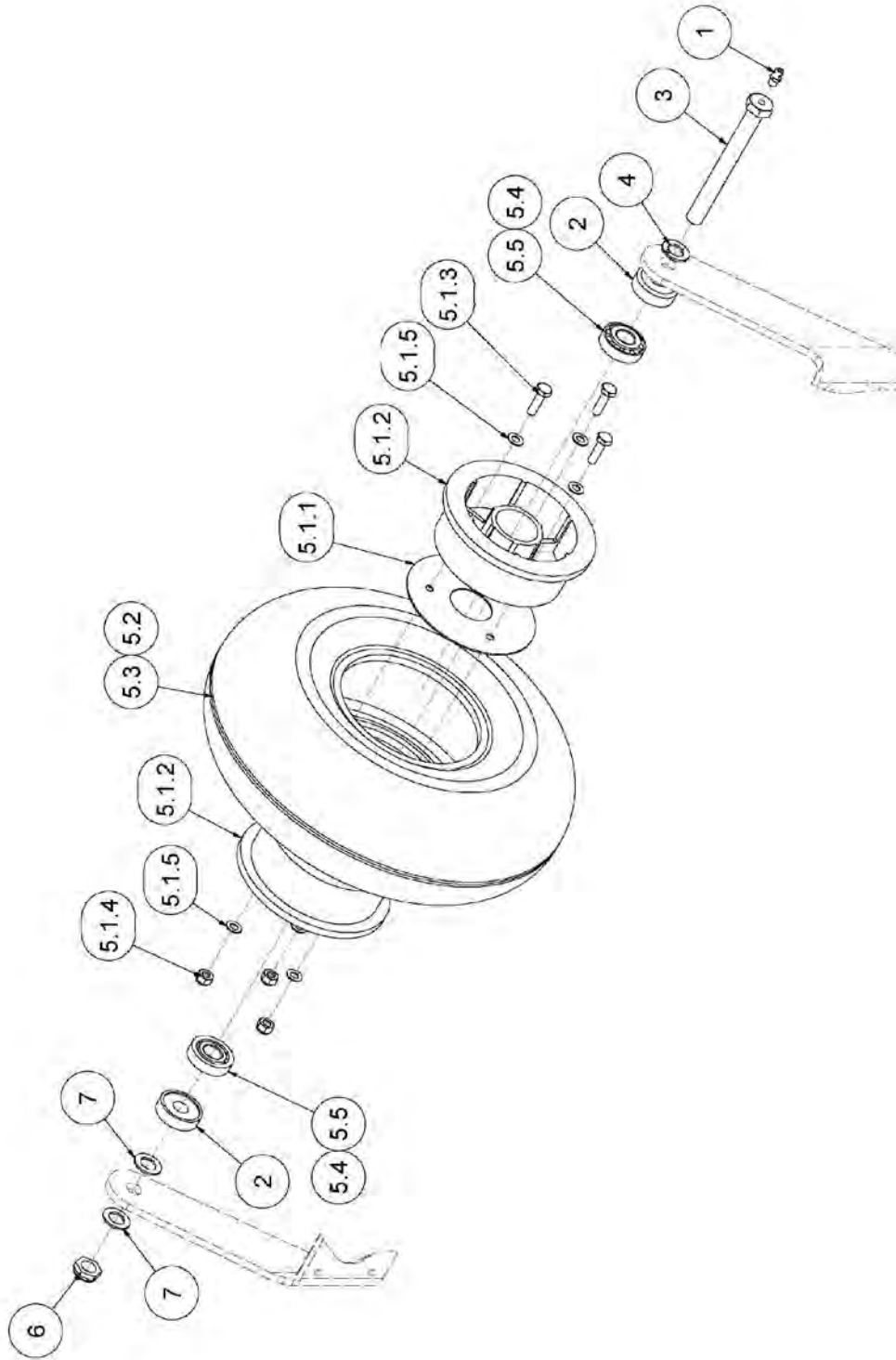

**ASSEMBLY – NOSE WHEEL (PARKER)**  
FIGURE 12B

**WIPLINE MODEL 2350 FLOAT PARTS MANUAL**

<b>ITEM</b>	<b>QTY</b>	<b>FIGURE 12B: NOSE WHEEL ASS'Y - PARKER PART DESCRIPTION</b>	<b>PART NO.</b>
1	1	COMMON GREASEZERK	1095K41
2	2	SPACER	3A06259-001
3	1	MODIFIED BOLT	3A06702-002
4	1	MODIFIED WASHER	3A06702-003
5	1	NOSE WHEEL ASSEMBLY	21A06000-021
5.1	1	PARKER WHEEL ASSEMBLY	D-30380
5.1.1	1	GASKET	068-30373
5.1.2	2	WHEEL HALF	161-30382
5.1.3	3	BOLT	AN4-7A
5.1.4	3	NUT	MS21044N4
5.1.5	6	WASHER	NAS1149F0432P
5.2	1	TIRE	XA1AA
5.3	1	TUBE	AD1A2
5.4	2	BEARING CORE	A4050
5.5	2	BEARING CONE	A4138
6	1	NUT	MS21083N8
7	2	WASHER	NAS1149D0863J



THIS PAGE INTENTIONALLY LEFT BLANK

**SECTION 7: MAIN GEAR ASSEMBLY**

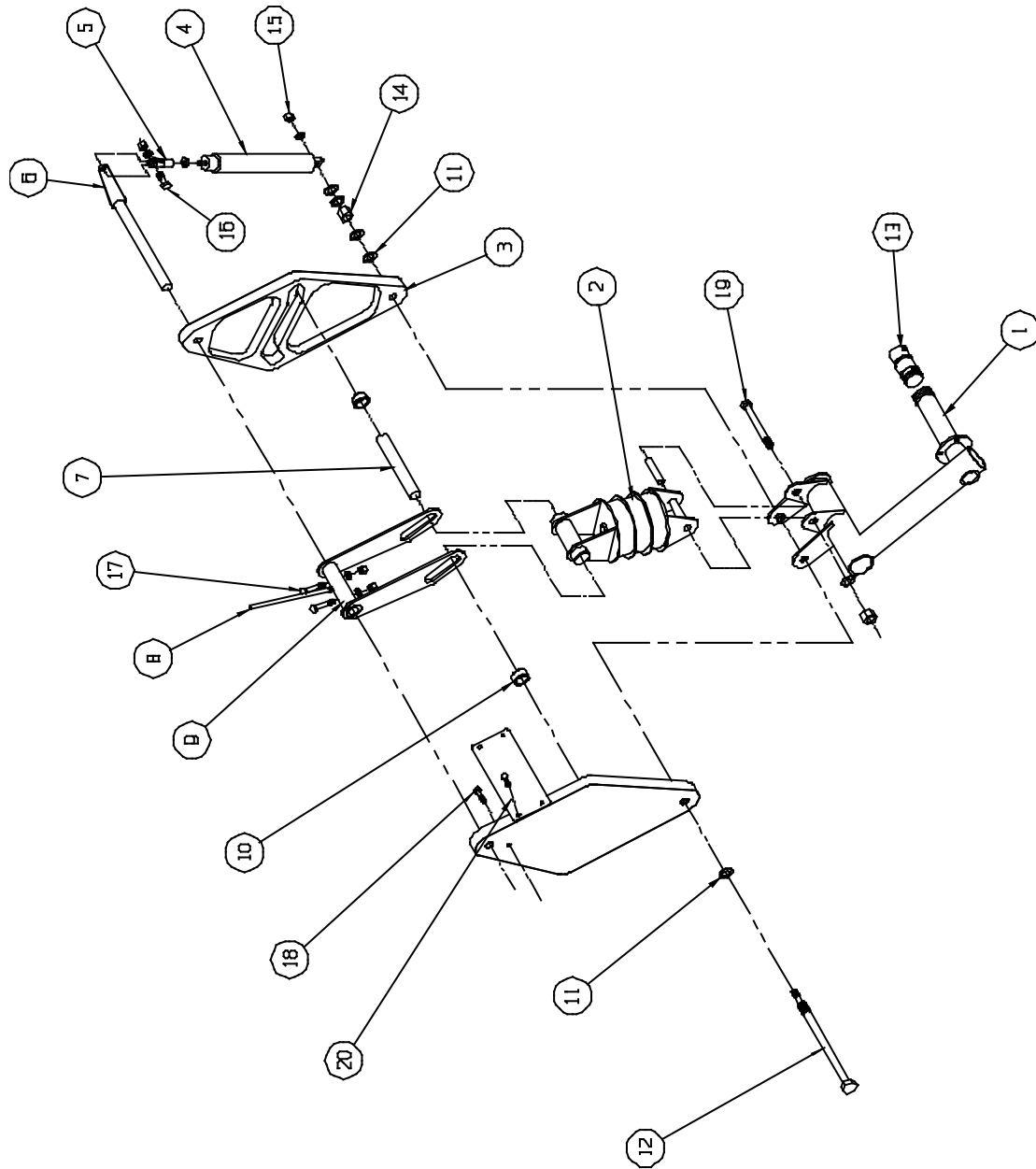

**INSTALLATION MAIN GEAR RETRACTION**  
**FIGURE 13**

**WIPLINE MODEL 2350 FLOAT PARTS MANUAL**

<b>FIGURE 13: INSTALLATION – MAIN GEAR RETRACTION</b>			
<b>ITEM</b>	<b>QTY</b>	<b>PART DESCRIPTION</b>	<b>PART NO.</b>
1	1	ASS'Y – DRAG LINK L.	21A04000-077
	1	ASS'Y – DRAG LINK R.	21A04000-076
	2	BEARING	08FDU12
2	1	ASS'Y SHOCK STRUT	23A04000-113
	1	ASS'Y – LOWER END	21A04000-075
	1	SLEEVE	21A04585-002
	2	ZERK – GREASE	1095K41
	1	ASS'Y – UPPER END	21A04000-074
	1	DUAL BUSHING ASSEMBLY	1002088
	1	BUSHING ASSEMBLY	1001101
	1	RETAINING PIN	21A04503-004
	1	COTTER PIN	MS24665-151
	2	WASHER	NAS1149F0416J
	2	WASER	NAS1149F0463J
3	1	TRACK – MAIN GEAR L.	21A05114-005
	1	TRACK – MAIN GEAR R.	21A05114-006
	1	BEARING - UPPER	10DU12
	1	BEARING – LOWER	08DU12
4	1	CYLINDER	1002574
	2	FITTING - ELBOW	MS20822-4D
5	1	ROD END	21A05705-002
	1	JAMB NUT	AN316-5
	1	SPACER	21A05260-005
	1	CHAMFERED WASHER	MS20002C6
		(CHAMFERED EDGE GOES AGAINST CYLINGER)	
6	1	ARM – RETRACT L.	21A05000-017
	1	ARM – RETRACT R.	21A05000-016
7	1	AXLE – SHOCK STRUT	21A04454-006
8	1	INDICTATOR ASS'Y	21A05000-022

**WIPLINE MODEL 2350 FLOAT PARTS MANUAL**

<b>FIGURE 13: INSTALLATION – MAIN GEAR RETRACTION</b>			
<b>ITEM</b>	<b>QTY</b>	<b>PART DESCRIPTION</b>	<b>PART NO.</b>
9	1	GEAR ACTUATOR	21A05000-018
10	2	ROLLER – TRACK	21A05520-003
11	2	WASHER – SEALING	93783A033
12	1	BOLT – ASSEMBLY	21A05000-019
13	1	RETAINER - GREASE	21A04263-007
	2	“O” RING	MS28775-210
	1	ZERK – GREASE	1095K41
14	1	NUT	MS21044N8
	2	WASHER	NAS1149F0863P
15	1	NUT	MS21083N5
	A/R	WASHER	NAS1149F0563P
16	1	BOLT	AN5-11A
	2	WASHER	NAS1149F0563P
	1	NUT	MS21044N5
17	2	BOLT	AN4-13A
	4	WASHER	NAS1149D0416J
	2	NUT	MS21044N4
18	8	BOLT – TRACK ATTACH	AN3-6A
	8	WASHER	NAS1149D0316J
	8	WASHER	NAS1149D0363J
	8	NUT	MS21044N3
19	1	BOLT	AN8-33A
	1	WASHER	NAS1149F0832P
	1	WASHER	NAS1149F0863P
	1	NUT	MS21044N8

**WIPLINE MODEL 2350 FLOAT PARTS MANUAL**

<b>FIGURE 13: INSTALLATION – MAIN GEAR RETRACTION</b>			
<b>ITEM</b>	<b>QTY</b>	<b>PART DESCRIPTION</b>	<b>PART NO.</b>
20	1	PLATE - SEPARATING	21A05003-079
	4	BOLT	AN3-5A
	8	WASHER	NAS1149D0316J
	4	NUT	MS21044N3

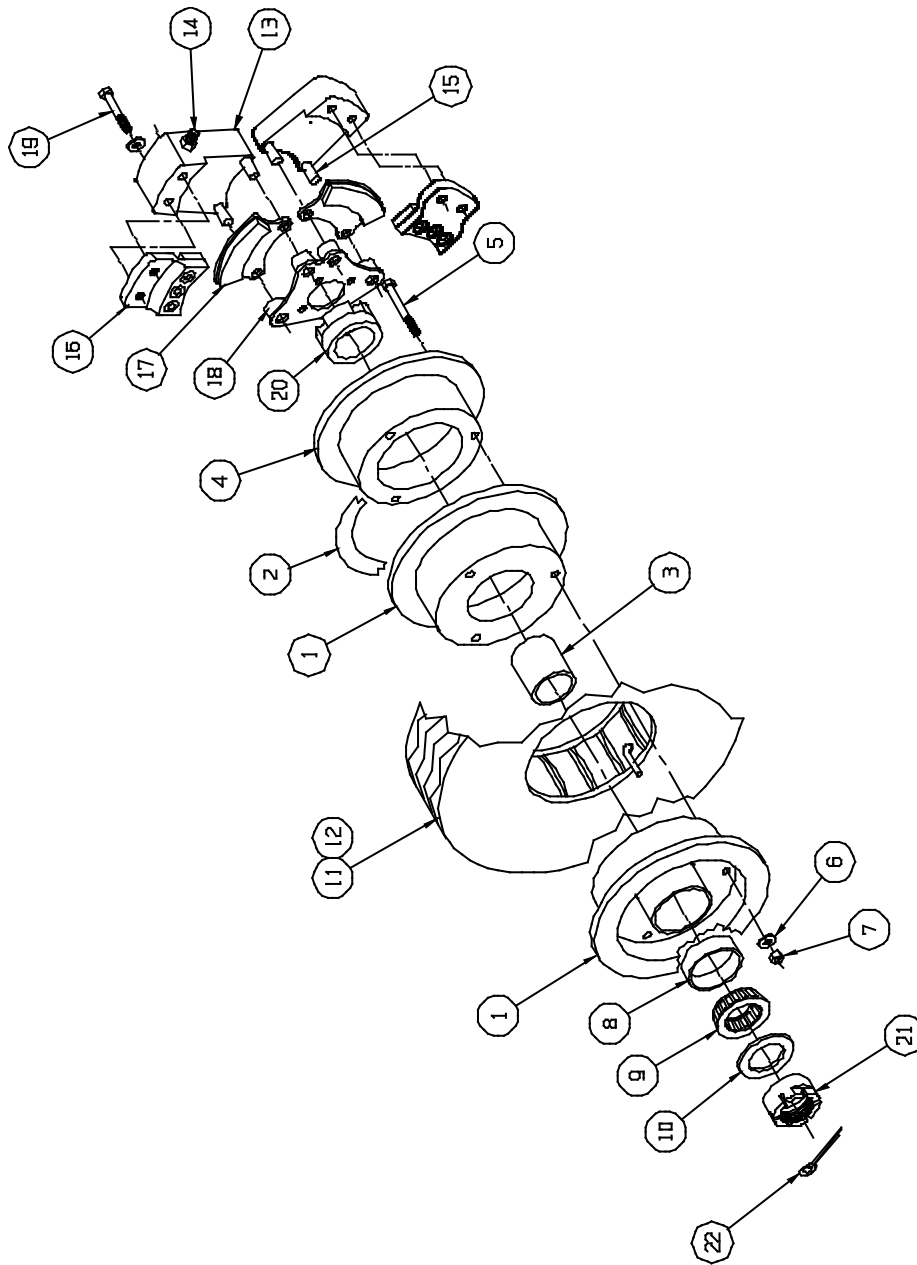

**ASSEMBLY MAIN GEAR WHEEL – CLEVELAND/PARKER**  
FIGURE 14A

**WIPLINE MODEL 2350 FLOAT PARTS MANUAL**

<b>ITEM</b>	<b>QTY</b>	<b>FIGURE 14A: MAIN GEAR WHEEL ASS'Y – CLEVELAND/PARKER PART DESCRIPTION</b>	<b>PART NO.</b>
1	1	ASS'Y – WHEEL (W/ TUBE & TIRE)	3A04000-002
	1	ASS'Y	3A04000-060
2	1	GASKET - TEFLON	3A04620-001
3	1	GREASE RETAINER	3A04616-001
4	1	BRAKE DISC	164-01700
5	3	BOLT	AN4-22A
6	3	WASHER	NAS1149F0432P
7	3	NUT	MS21044N4
8	2	BEARING CUP	8231
		BEARING CUP, CHROME (OPT.)	8231CP
9	2	BEARING CONE	8125
		BEARING CONE, CHROME (OPT.)	8125CP
10	2	SEAL - INSIDE/OUTSIDE	473237
11	1	TIRE –TYPE III	500 X 5, 6 PLY
	1	TUBE	500 X 5
12	2	ASS'Y – BRAKE AND TORQUE PLATE	3A04000-052
13	2	ASS'Y – CALIPER	030-00903
	2	PISTON	062-00300
	2	“O” RING	AN6227-23
	2	FITTING - 45 DEGREES (BRAKE LINE)	MS20823-3D
14	2	SEAT – BLEEDER	081-30619
	2	SCREW – BLEEDER	79-3
	2	CAP – BLEEDER	183-1



**WIPLINE MODEL 2350 FLOAT PARTS MANUAL**

<b>ITEM</b>	<b>QTY</b>	<b>FIGURE 14A: MAIN GEAR WHEEL ASS'Y – CLEVELAND/PARKER PART DESCRIPTION</b>	<b>PART NO.</b>
15	4	ANCHOR BOLT	069-00400
	4	WASHER	NAS1149F0463P
	4	NUT	MS21044N4
16	2	ASS'Y – BACK PLATE	074-02700
	2	PLATE – BACK	064-00500
	2	LINING	066-10600
	6	RIVET	105-2
17	2	ASS'Y – PRESSURE PLATE	073-04800
	2	PLATE - PRESSURE	063-00500
	2	LINING	066-10600
	6	RIVET	105-2
18	1	BRAKE TORQUE PLATE - LEFT	23A04000-109
	1	BRAKE TORQUE PLATE – RIGHT	23A04000-110
19	4	BOLT	AN4H15A
	4	WASHER	NAS1149F0432P
20	1	SPACER	3A04093-001
21	1	NUT – AXLE	3A04268-003
22	1	COTTER PIN	MS24665-351

THIS PAGE INTENTIONALLY LEFT BLANK

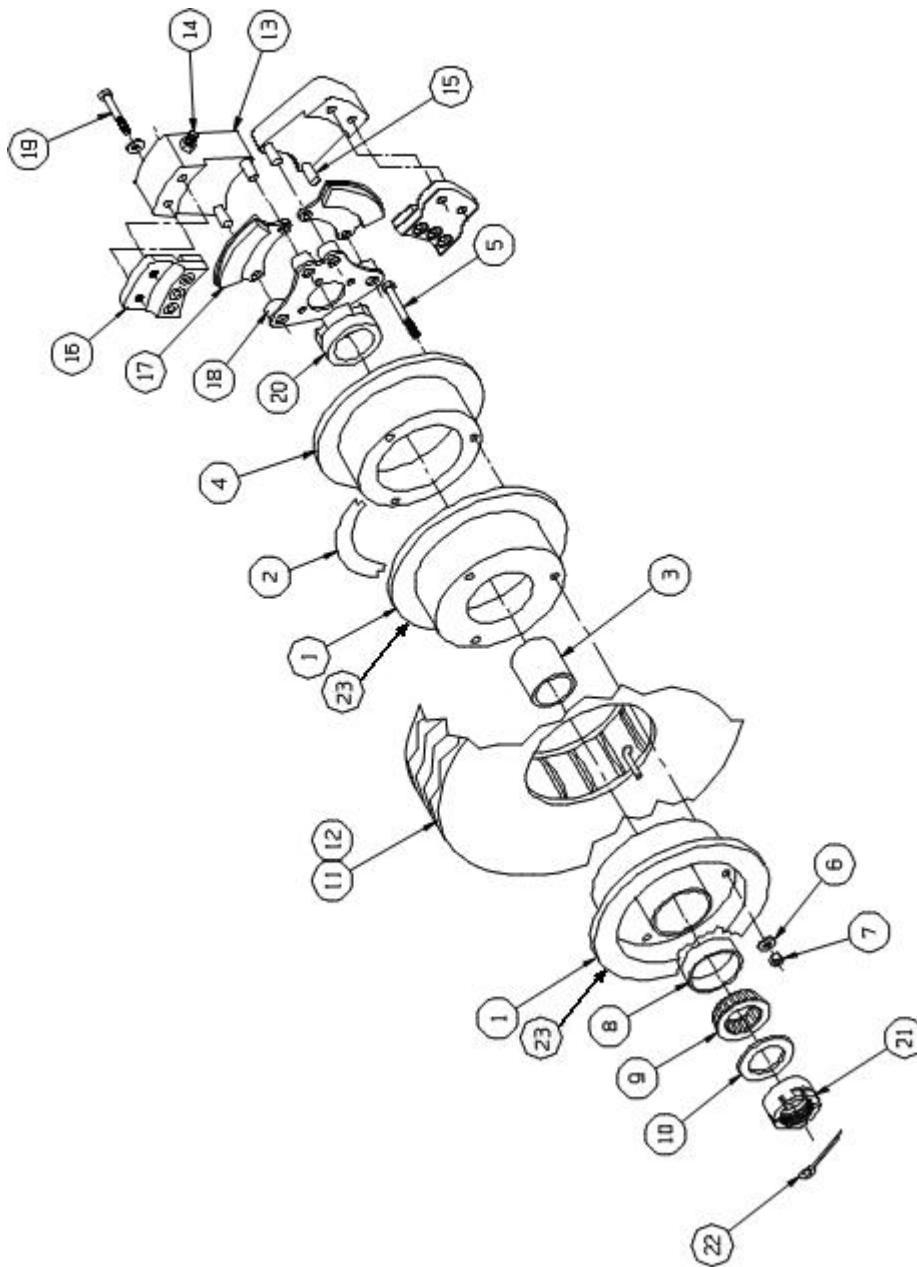

**ASSEMBLY – MAIN GEAR WHEEL – GROVE/WIPAIRE**  
FIGURE 14B

**WIPLINE MODEL 2350 FLOAT PARTS MANUAL**

<b>ITEM</b>	<b>QTY</b>	<b>FIGURE 14B: MAIN GEAR ASS'Y – GROVE/WIPAIRE PART DESCRIPTION</b>	<b>PART NO.</b>
1	1	ASS'Y – WHEEL AND BRAKE (COMPLETE)	1002144
		INCLUDES ALL ITEMS BELOW EXCEPT TIRE & TUBE	
2	1	GASKET - TEFLON	3A04620-001
3	1	GREASE RETAINER	010-009
4	1	BRAKE DISC	018-002
5	3	BOLT	AN4-23A
6	3	WASHER	NAS1149F0432P
7	3	NUT	MS21044N4
8	2	BEARING RACE, NON-CHROME	08125
9	2	BEARING CUP, NON-CHROME	08231
10	2	SEAL - INSIDE/OUTSIDE	473237
		<i>DRILL #50 HOLE IN SIDE OF SEAL TO BE USED IN OUTBOARD SIDE OF WHEEL.</i>	
11	1	TIRE –TYPE III 5.00 X 5-6	AA104
12	1	TUBE 5.00	XA1AC
13	1	BRAKE ASSEMBLY	32-3
	2	PISTON	017-003
	2	O-RING	MS28775-217
14	1	BLEEDER ASSEMBLY	220-0063
	1	FITTING 45° BRAKE LINE	MS20823-3D
15	2	TORQUE PIN	013-001
	2	NUT	MS21044N4
16	1	BACK PLATE ASSEMBLY	10-3
	1	PAD	66-111

**WIPLINE MODEL 2350 FLOAT PARTS MANUAL**

<b>ITEM</b>	<b>QTY</b>	<b>FIGURE 14B: MAIN GEAR ASS'Y – GROVE/WIPAIRE PART DESCRIPTION</b>	<b>PART NO.</b>
	3	RIVET	105-2
17	1	PRESSURE PLATE ASSEMBLY	11-2
	1	LINING	66-111
	3	RIVET	105-2
18	1	BRAKE TORQUE PLATE ASSEMBLY	020-001
19	3	BOLT	AN4H-15A
	3	WASHER	NAS1149F0432P
20	1	SPACER	3A04093-001
21	1	NUT – AXLE	3A04268-003
22	1	COTTER PIN	MS24665-351
23	1	WHEEL HALF-INNER	015-002
	1	WHEEL HALF-OUTER	016-002
		<i>(HALVES NOT SOLD SEPERATELY)</i>	

**SECTION 8: INSTALLATION – STRUTS, WIRES, SPREADER BARS,  
STEPS**

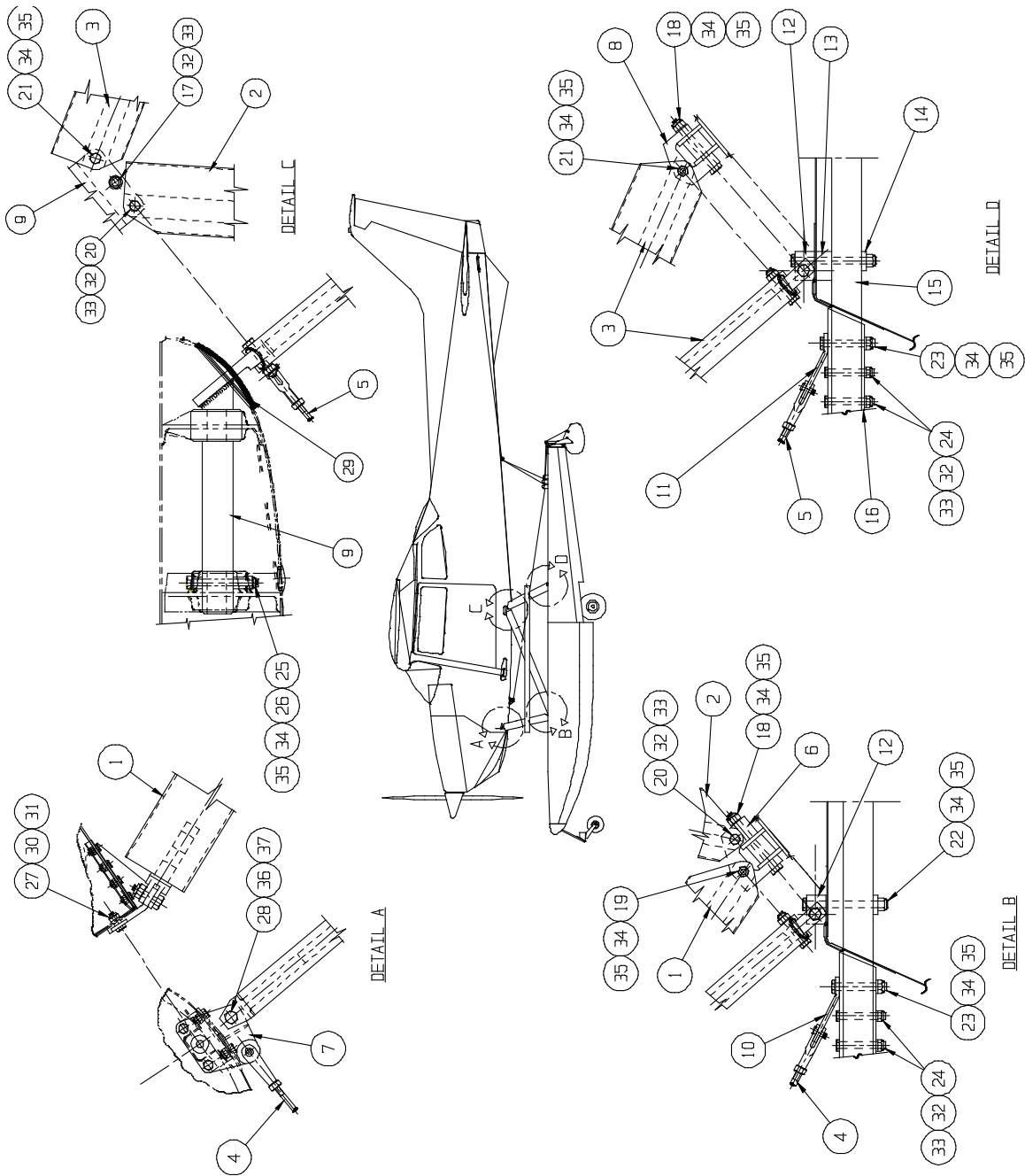

INSTALLATION – STRUTS, WIRES AND SPREADER BARS - CESSNA 172  
 FIGURE 15

**WIPLINE MODEL 2350 FLOAT PARTS MANUAL**

<b>FIGURE 15B: INSTALL. – STRUTS, WIRES, SPR. BARS – CESSNA 172</b>			
<b>ITEM</b>	<b>QTY</b>	<b>PART DESCRIPTION</b>	<b>PART NO.</b>
1	2	ASS'Y – FRONT STRUT	23A02000-174
	1	FITTING - UPPER	23A02053-010
	4	BOLT – FITTING ATTACH	AN5-16A
	8	WASHER	NAS1149F0563P
	4	NUT	MS21044N5
	1	STRUT – BLANK WITH BUSHINGS	21A02334-020
	4	WASHER	NAS1149F0532P
2	2	ASS'Y - STRUT – CENTER WITH BUSHINGS	23A02000-230
3	2	ASS'Y – STRUT – REAR WITH BUSHINGS	21A02000-161
4	2	ASS'Y – DRAG WIRE – FWD	1002111
	2	CLEVIS - PIN	SP4ZF6
	2	PIN – COTTER	SP90C5
	1	TERMINAL CLEVIS “L”	AN665-46LS <sup>1</sup>
	1	TERMINAL CLEVIS “R”	AN665-46RS *
	1	CHECK NUT “L”	AN316C5L
	1	CHECK NUT “R”	AN316C5R
5	2	ASS'Y – DRAG WIRE – AFT	21A02000-137
	2	PIN - CLEVIS	SP4ZF6
	2	PIN – COTTER	SP90C5
	1	TERMINAL CLEVIS “L”	AN665-46LS *
	1	TERMINAL CLEVIS ”R”	AN665-46RS *
	1	CHECK NUT “L”	AN316C5L
	1	CHECK NUT “R”	AN316C5R
6	2	FITTING – LOWER FRONT STRUT	21A02062-009
7	1	ASS'Y - FITTING – UPPER FRONT STRUT L.	21A02000-141
	1	ASS'Y – FITTING – UPPER FRONT STRUT R.	21A02000-142
8	2	FITTING – LOWER AFT STRUT	21A02062-010

<sup>1</sup> “S” DENOTES STAINLESS STEEL



**WIPLINE MODEL 2350 FLOAT PARTS MANUAL**

<b>ITEM</b>	<b>QTY</b>	<b>FIGURE 15B: INSTALL. – STRUTS, WIRES, SPR. BARS – CESSNA 172 PART DESCRIPTION</b>	<b>PART NO.</b>
9	1	ASS'Y – MAIN FUSELAGE FITTING L.	23A02000-219
	1	ASS'Y – MAIN FUSELAGE FITTING R.	23A02000-222
10	2	WIRE PULL LOWER FWD	21A02462-005
11	2	WIRE PULL LOWER AFT	21A02519-007
12	4	BLOCK – DECK FITTING	21A03032-006
13	4	SPACER	21A03214-003
14	4	SPACER – BEARING	21A03154-008
15	4	TUBE – SPREADER BAR MOUNT	21A03115-001
16	2	SPREADER BAR	21A03356-047
17	2	EYEBOLT	AN45-12A
18	2	BOLT	AN6-31A
19	2	BOLT	AN6-17A
20	4	BOLT	AN5-16A
21	4	BOLT	AN6-17A
22	4	BOLT	AN6-42A
23	4	BOLT	AN6-26A
24	8	BOLT	AN5-24A
25	2	BOLT	AN6-35A
26	4	BUSHING	21A02095-003

**WIPLINE MODEL 2350 FLOAT PARTS MANUAL**

<b>ITEM</b>	<b>QTY</b>	<b>FIGURE 15B: INSTALL. – STRUTS, WIRES, SPR. BARS – CESSNA 172 PART DESCRIPTION</b>	<b>PART NO.</b>
27	10	BOLT	AN4-6A
28	2	BOLT	AN7-13A
29	2	COVER – GEAR OPENING	21A02010-018
30	A/R	WASHER	NAS1149D0463J
31	10	NUT	MS21044N4
32	A/R	WASHER	NAS1149D0563J
33	6	NUT	MS21044N5
34	A/R	WASHER	NAS1149D0663J
35	18	NUT	MS21044N6
36	A/R	WASHER	NAS114D0763J
37	2	NUT	MS210365-720A

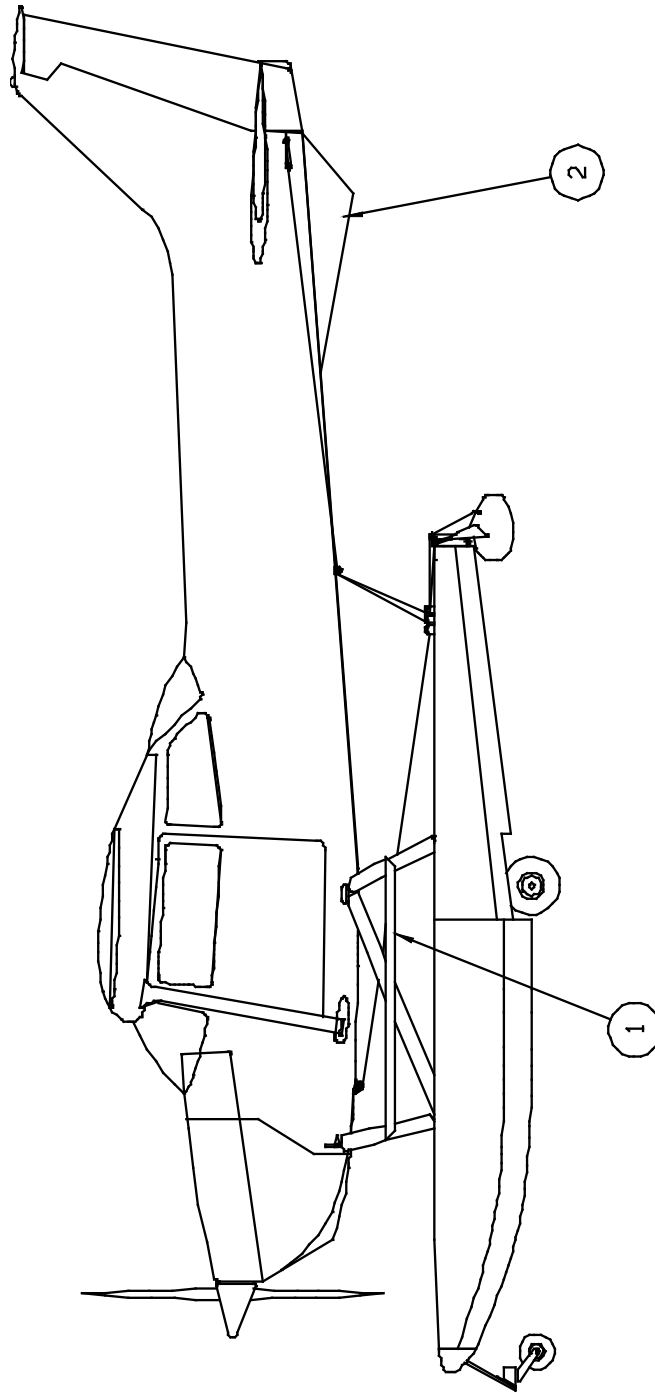

**INSTALLATION – FUSELAGE STEPS - CESSNA 172**  
FIGURE 16

**WIPLINE MODEL 2350 FLOAT PARTS MANUAL**

<b>ITEM</b>	<b>QTY</b>	<b>FIGURE 16: INSTALLATION – FUSELAGE STEPS – CESSNA 172 PART DESCRIPTION</b>	<b>PART NO.</b>
1	2	STEP – L. & R.	21A02369-035
	4	BOLT – ATTACH	AN3-20A
	2	BOLT – ATTACH	AN3-24A
	12	WASHER	NAS1149D0363J
	6	NUT	MS21044N3
	6	HOLE PLUG	1”
	4	SPACER – FRONT STRUT	6A02273-006
2	1	ASS’Y – VENTRAL FIN	21A12000-042
	10	RIVNUTS	B8-75
	14	PLATENUT	MS21078-08
	24	SCREW – ATTACH	AN526-1032R8
	24	WASHER	NAS1149D0363J
	10	WASHER – LOCK	MS35333-39

THIS PAGE INTENTIONALLY LEFT BLANK

**SECTION 9: STEERING AND RETRACT SYSTEM – CESSNA 172**

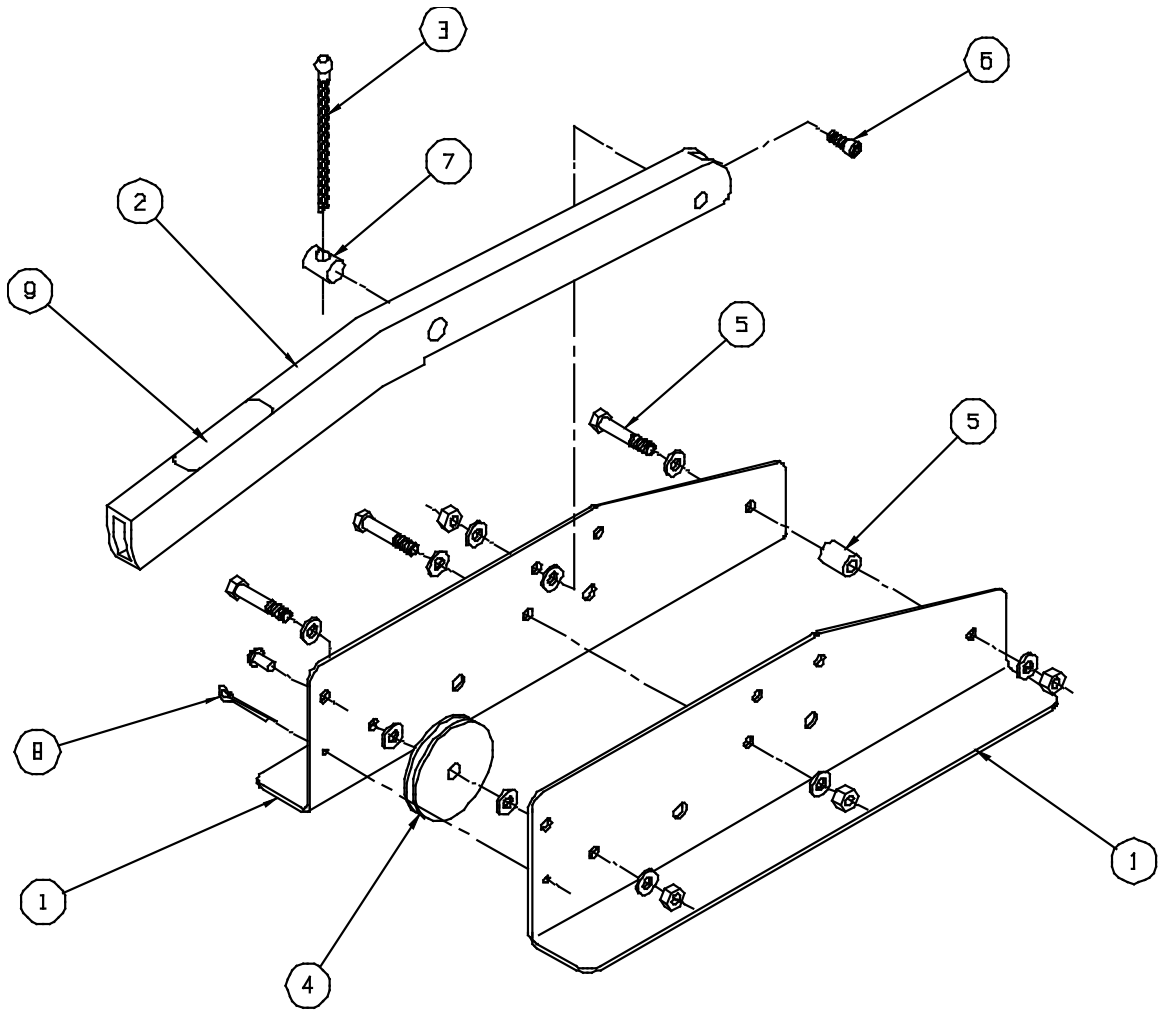

**ASSEMBLY – RETRACT HANDLE CESSNA 172**  
FIGURE 17

**WIPLINE MODEL 2350 FLOAT PARTS MANUAL**

<b>FIGURE 17: ASSEMBLY –RETRACT HANDLE – CESSNA 172</b>			
<b>ITEM</b>	<b>QTY</b>	<b>PART DESCRIPTION</b>	<b>PART NO.</b>
1	1	ASS'Y – RETRACT HANDLE	21A08000-128
	1	BRACKET SIDE L.	3A08003-015
	1	BRACKET SIDE R.	3A08003-016
2	1	HANDLE	3A08414-001
3	1	CABLE ASS'Y	21A08000-137
4	1	PULLEY	MS20219-2
	1	BOLT – ATTACH	AN4-10A
	2	WASHER	NAS1149F0463P
	1	NUT	NAS679A4W
5	2	BOLT	AN3-10A
	2	BUSHING – PLASTIC	3A08613-001
	8	WASHER	NAS1149F0316P
	4	NUT	NAS679A3W
6	2	PIN PIVOT	3A08702-006
	2	WASHER	NAS1149F0432P
	2	NUT	NAS679A3W
7	1	SWIVEL	4A08506-002
8	1	PIN – COTTER	MS24665-285
9	1	PLACARD – DOWN	3A3-1115-2
	1	PLACARD – UP	3A3-1115-3
	1	PLACARD – WATER RUDDER CONTROL	3A3-1115-1



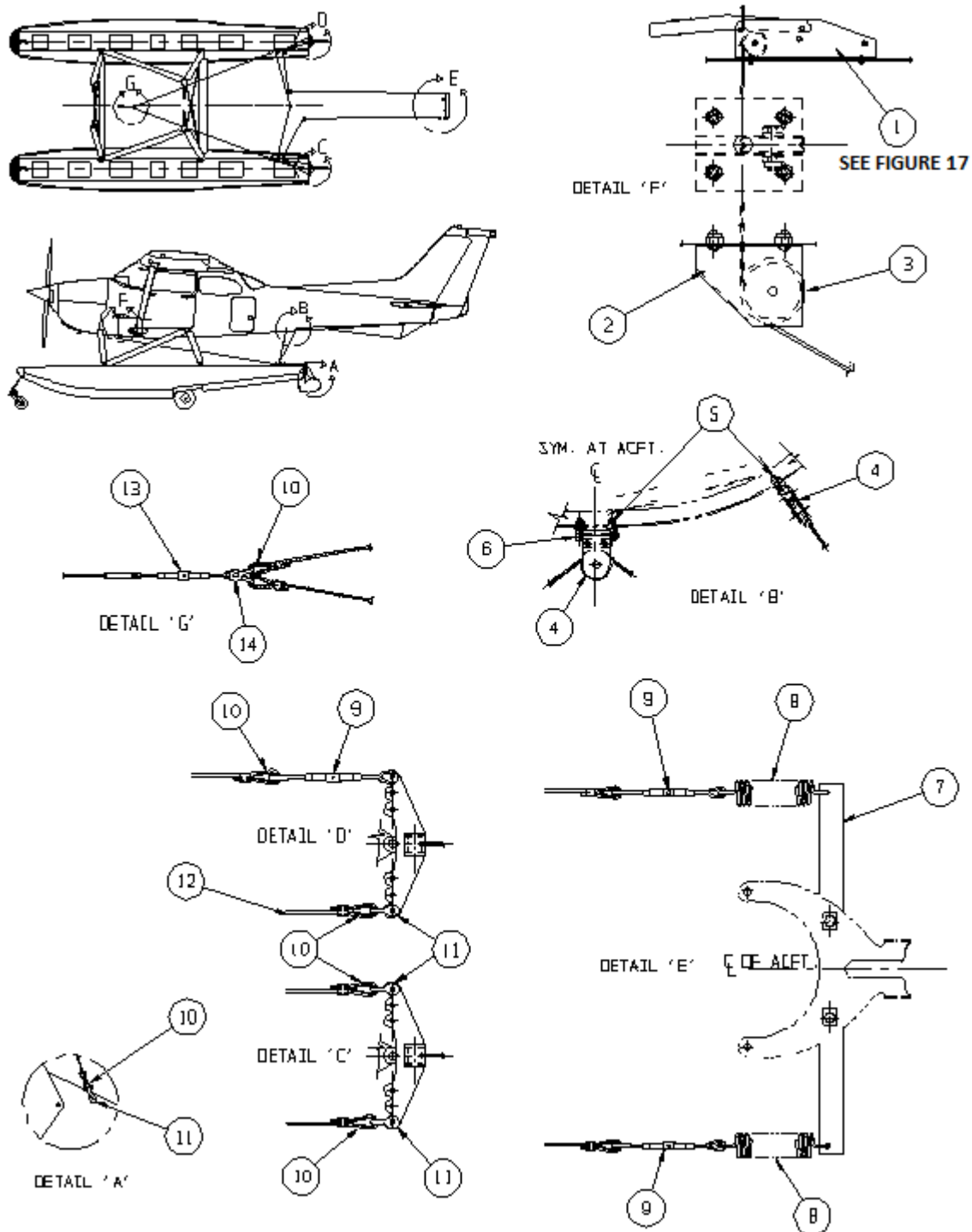

**INSTALLATION – STEERING AND RETRACT SYSTEM CESSNA 172**  
**FIGURE 18**

**WIPLINE MODEL 2350 FLOAT PARTS MANUAL**

<b>ITEM</b>	<b>QTY</b>	<b>FIGURE 18: INSTALLATION – STEERING AND RETRACT SYSTEM PART DESCRIPTION</b>	<b>PART NO.</b>
1	1	ASS'Y – RETRACT HANDLE	21A08000-128
		SEE FIGURE 17	
	4	SCREW - ATTACH	AN526-1032R8
	4	WASHER	NAS1149D0363J
	4	NUT	MS21044N3
2	1	PULLEY BRACKET	3A08151-046
	4	SCREW – ATTACH	AN526-1032R8
	4	WASHER	NAS1149D0316J
	4	NUT	MS21044N3
3	1	PULLEY	MS20219-2
	1	BOLT	AN4-7A
	2	WASHER	NAS1149D0463J
	1	NUT	MS21044N4
4	3	ASS'Y – PULLEY BRACKET	21A08000-125
	1	BRACKET	21A08008-150
	1	SPACER - BLOCK	21A08230-002
	1	PULLEY	MS20219-2
	1	BOLT	AN4-7A
	1	WASHER	NAS1149D0416J
	1	NUT	MS21083N4
	1	WASHER	NAS1149D0463J
5	6	EYE BOLT	AN42B4A
	6	WASHER	NAS1149D0363J
	6	NUT	MS21044N3
6	3	BOLT	AN3-17A
	3	WASHER	NAS1149D0363J
	3	NUT	MS21044N3
7	1	EXTENSION – RUDDER HORN	21A08359-201
	2	BOLT – ATTACH	AN3-6A
	2	WASHER	NAS1149D0363J
	2	NUT	MS21044N3

**WIPLINE MODEL 2350 FLOAT PARTS MANUAL**

<b>FIGURE 18: INSTALLATION – STEERING AND RETRACT SYSTEM</b>			
<b>ITEM</b>	<b>QTY</b>	<b>PART DESCRIPTION</b>	<b>PART NO.</b>
8	2	SPRING	21A08525-005
9	3	TURNBUCKLE – BARREL	MS21251B3S
	3	FORK – TERMINAL	MS21252-3RS
	3	PIN ATTACH	MS20392-2-1
	3	PIN – COTTER	MS24665-132
	3	WASHER	NAS1149D0316J
10	10	THIMBLE – CABLE	AN100-3
	10	NICOPRESS – CLAMP	18-2-G
11	5	SHACKLE	MS20115-3
	5	PIN – ATTACH	MS20392-2-11
	5	PIN – COTTER	MS24665-132
12	A/R	CABLE (REQUEST LENGTH)	3/32 7X 7 S.S.
13	1	BARREL	MS21251B3S
	1	FORK	MS21252-3RS
14	2	SHACKLE	MS20115-3
	1	PIN – CLEVIS	MS20392-2-19

**SECTION 10: INSTALLATION - HYDRAULIC SYSTEM**

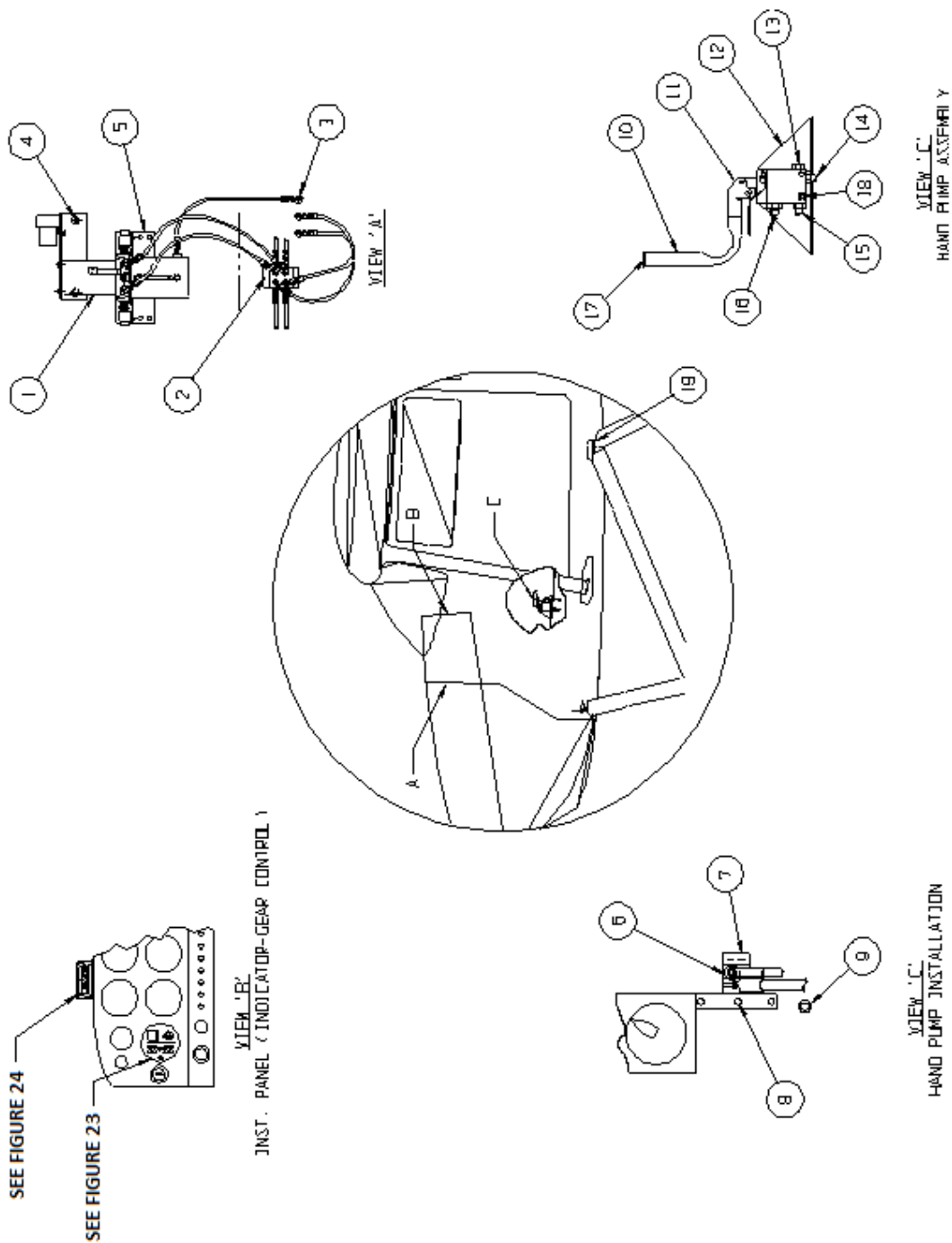

INSTALLATION – HYDRAULIC SYSTEM CESSNA 172  
FIGURE 19

**WIPLINE MODEL 2350 FLOAT PARTS MANUAL**

<b>FIGURE 19: INSTALLATION – HYDRAULIC SYSTEM – CESSNA 172</b>			
<b>ITEM</b>	<b>QTY</b>	<b>PART DESCRIPTION</b>	<b>PART NO.</b>
1	1	ASS'Y - PUMP 12V	21A09000-239
	1	ASS'Y – PUMP 24V	21A09000-283
		SEE FIGURE 20 (BREAK DOWN)	
2	1	ASS'Y – MANIFOLD	21A09000-240
	1	MANIFOLD	6A09046-001
	4	NIPPLE – FITTING	AN816-4-4D
	2	BOLT - ATTACH	AN3-5A
	2	WASHER	NAS1149F0363P
	2	NUT	MS21044N3
	4	NIPPLE FITTING	AN816-4D
3	3	UNION - FIREWALL	AN832-4D
	3	WASHER	NAS1149F0763P
	3	NUT	AN924-4D
4	2	BOLT - TOP BRACKET ATTACH	AN3-4A
	4	WASHER	NAS1149D0363J
5	1	ANGLE – LOWER PUMP ATTACH	21A09348-020
	4	BOLT	AN3-4A
	4	WASHER	NAS1149D0363J
	4	NUT	MS21044N3
6	1	ASS'Y – HAND PUMP	21A09000-194
7	1	ASS'Y – SELECTOR HANDLE	21A12000-052
	1	PLACARD	12A3-7379-1
8	3	BOLT – ATTACH	AN3-4A
	3	WASHER	AN970-3
	3	WASHER	NAS1149D0363J
	3	NUT	MS21044N3
9	1	GROMMET	MS35489-49

**WIPLINE MODEL 2350 FLOAT PARTS MANUAL**

<b>FIGURE 19: INSTALLATION – HYDRAULIC SYSTEM – CESSNA 172</b>			
<b>ITEM</b>	<b>QTY</b>	<b>PART DESCRIPTION</b>	<b>PART NO.</b>
10	1	HANDLE - PUMP	21A09396-001
11	1	HAND PUMP (ONLY)	642873
12	1	BRACKET – PUMP ATTACH	21A09156-129
13	1	PLUG	AN814-4D
	1	“O” RING	MS28775-012
14	1	UNION	21A09746-001
	1	“O” RING	MS28775-012
15	1	UNION	AN815-4D
	1	“O” RING	MS28775-012
16	1	UNION	AN919-6D
	1	“O” RING	MS28775-014
17	1	CAP PLUG	9283K13
18	2	CAP SCREW – ATTACH	5/16-18 UNC-28 X .63
	2	LOCK WASHER	MS35333-40
	2	WASHER	NAS1149F0563P
19	2	ASS’Y – BRAKE LINE (NOT SHOWN)	21A04000-080
	2	FITTING	63-190600-3

THIS PAGE INTENTIONALLY LEFT BLANK



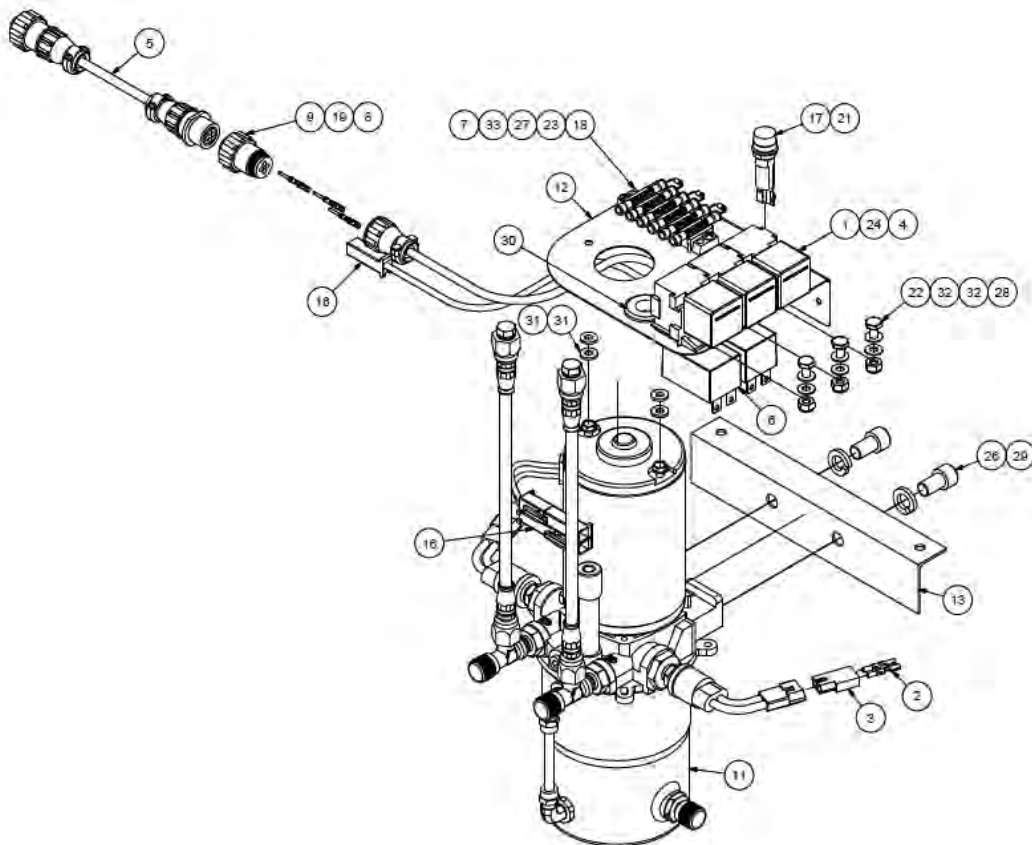
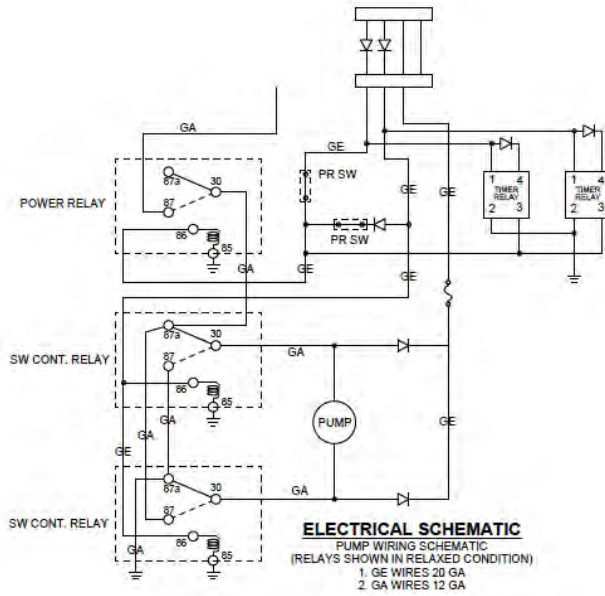

**ASSEMBLY – HYDRAULIC PUMP**  
 FIGURE 20

**WIPLINE MODEL 2350 FLOAT PARTS MANUAL**

<b>FIGURE 20: ASSEMBLY – HYDRAULIC PUMP</b>			
<b>ITEM</b>	<b>QTY</b>	<b>PART DESCRIPTION</b>	<b>PART NO.</b>
1	3	RELAY, 12V, 5 PRONG	0-332-209-137
	3	RELAY, 24V, 5 PRONG	0-332-209-211
2	4	PIN, CRIMP FEMALE, 1/8" DIA	02-09-1104
3	2	CONNECTOR PLUG, MALE, 2 CONN.	03-09-1022
4	14	TERMINAL	1-901-355-917
5	1	CABLE, DIODE ADAPTOR	1004949
6	1	TIMER RELAY HARNESS	1005042
7	3	DIODE, 2-1/2"	1N4004
8	2	CLAMP, CABLE, CPC SIZE 11	206062-3
9	1	PLUG, MALE, CPC SIZE 1, 4 PIN	206429-1
10	1	CPC FREE HANG, 4 PIN, FEMALE	206430-2
11	1	ASSEMBLY, HYDRAULIC PUMP, 12V	21A09000-215
	1	ASSEMBLY, HYDRAULIC PUMP, 24V	21A09000-282
12	1	SUPPORT, HYD. PUMP ATTCH	21A09005-264
13	1	ANGLE, MOUNTING, HYD. PUMP	21A09352-030
14	6 FT	WIRE, 12 AWG, WHITE	22759-16-12-9
15	10.1 FT	WIRE, 20 AWG, WHITE	22759-16-20-9
16	3	HOUSING CONNECTOR ASSEMBLY	2601048-200
17	1	FUSE HOLDER	3453LF2A

**WIPLINE MODEL 2350 FLOAT PARTS MANUAL**

<b>FIGURE 20: ASSEMBLY – HYDRAULIC PUMP</b>			
<b>ITEM</b>	<b>QTY</b>	<b>PART DESCRIPTION</b>	<b>PART NO.</b>
18	1	TERMINAL BLOCK, 6 CONNECTOR	6-140
19	3	PIN, CRIMP SOCKET, 24-20G	66103-4
20	3	CRIMP SOCKET, FEMALE	66105-4
21	1	FUSE, 250V, (S2565-1)	AGC-1
22	3	BOLT	AN3-3A
23	2	SCREW, MACHINE, TRUSS HEAD	AN526-632R8
24	3	SOCKET, 5 PRONG, PLASTIC	BR05FW
25	1.5 FT	HEAT SHRINK, TUBING, BLACK	HS105-3/16-0
26	2	SOCKET HEAD CAP SCREW	MS16997-96
27	2	NUT	MS21044N06
28	3	NUT	MS21044N3
29	2	WASHER, SPLIT	MS35338-46
30	1	GROMMET, RUBBER	MS35489-14
31	4	WASHER	NAS1149D0363J
32	6	WASHER	NAS1149F0332P

THIS PAGE INTENTIONALLY LEFT BLANK

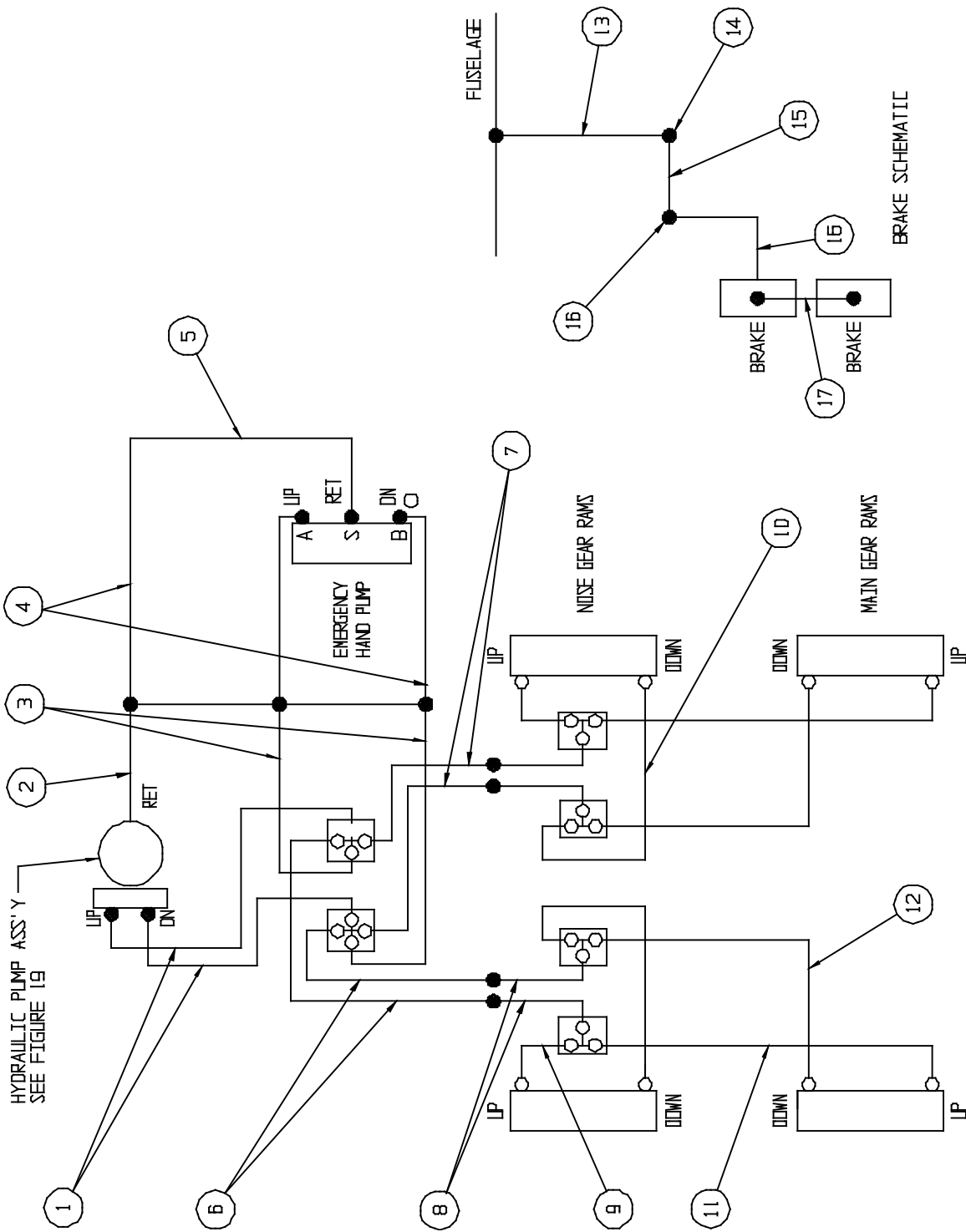

**HYDRAULIC SCHEMATIC**  
FIGURE 21

**WIPLINE MODEL 2350 FLOAT PARTS MANUAL**

<b>ITEM</b>	<b>QTY</b>	<b>FIGURE 21: HYDRAULIC SCHEMATIC PART DESCRIPTION</b>	<b>PART NO.</b>
1	2	ASS'Y – HYDRAULIC HOSE	21A09000-197
2	1	ASS'Y – HYDRAULIC HOSE	21A09000-201
3	2	ASS'Y – HYDRAULIC HOSE	21A09000-200
4	2	ASS'Y – HYDRAULIC HOSE	21A09000-202
5	1	ASS'Y – HYDRAULIC HOSE	21A09000-203
6	2	ASS'Y – HYDRAULIC HOSE	21A09000-198
7	2	ASS'Y – HYDRAULIC HOSE	21A09000-199
8	4	ASS'Y – HYDRAULIC HOSE	21A09000-222
9	2	ASS'Y – HYDRAULIC HOSE	23A09000-235
10	2	ASS'Y – HYDRAULIC HOSE	23A09000-236
11	2	ASS'Y – HYDRAULIC HOSE	23A09000-237
12	2	ASS'Y – HYDRAULIC HOSE	23A09000-238
13	2	ASS'Y – HYDRAULIC HOSE	21A04000-080
	2	FITTING – ENDS	63-190600-3
14	2	FITTING – ELBOW	AN833-3D
	4	WASHER	NAS1149D0663J
	2	NUT	AN924-3D
15	2	LINE ASS'Y – HARD	21A04000-079
16	2	LINE ASS'Y – FLEX	21A04000-078
17	2	LINE ASS'Y – FLEX BRAKE	23A04000-118

THIS PAGE INTENTIONALLY LEFT BLANK

**SECTION 11: ELECTRICAL SCHEMATIC**



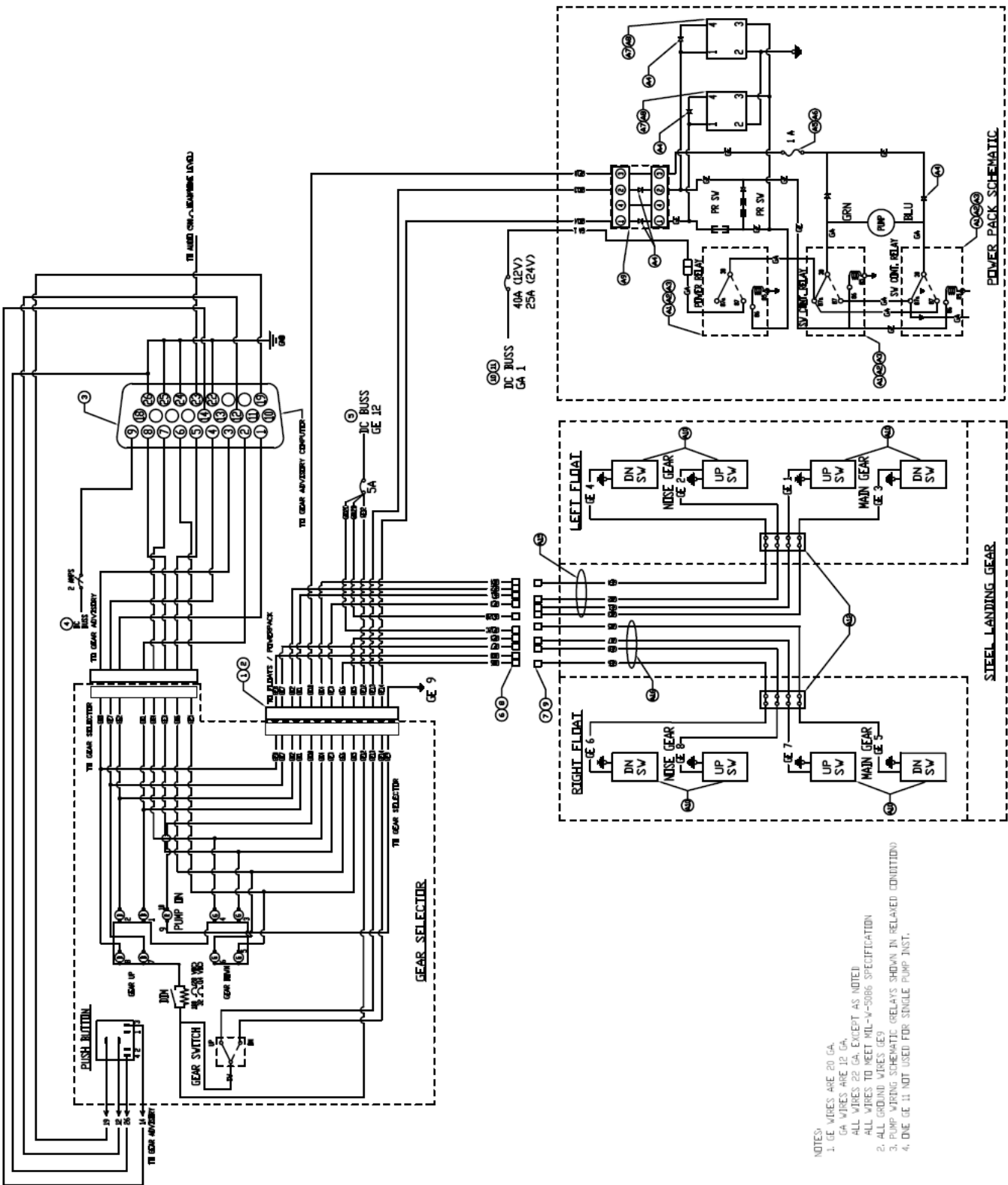

- NOTES:
1. GE WIRES ARE 20 GA.
  - GA WIRES ARE 12 GA.
  - ALL WIRES TO MEET MIL-V-5086 SPECIFICATION
  2. ALL GROUND WIRES GE9
  3. PUMP WIRING SCHEMATIC (RELAYS SHOWN IN RELEASED CONDITION)
  4. ONE GE 11 NOT USED FOR SINGLE PUMP INST.

ELECTRICAL SCHEMATIC  
FIGURE 22

**WIPLINE MODEL 2350 FLOAT PARTS MANUAL**

<b>FIGURE 22: ELECTRICAL SCHEMATIC</b>			
<b>ITEM</b>	<b>QTY</b>	<b>PART DESCRIPTION</b>	<b>PART NO.</b>
1	1	ASSY, WIRING HARNESS, GEAR SELECTOR	4A11000-011
3	1	ASSY, WIRING HARNESS, GEAR ADVISORY	4A11000-014
4	1	BREAKER, CIRCUIT, KLIXON, 2AMP	7277-2-2
5	1	BREAKER, CIRCUIT, KLIXON, 5AMP	7277-2-5
6	8	PIN	S1635-1SF
7	8	SOCKET	S1636-1
8	8	HOUSING	S1637-1
9	8	HOUSING	S1637-2
10	1	BREAKER, CIRCUIT, 25AMP	W-23- X1A1G-25
11	1	BREAKER, CIRCUIT, 40AMP	W-23-X1A1G-40
A1	3	RELAY 12V	0-332-209-211
A2	3	RELAY 24V	0-332-209-137
A3	3	RELAY SOCKET	BR05FW'
A4	7	DIODE	1N4004
A5	1	FUSE 1 AMP	AGC-1
A6	1	FUSE HOLDER	3453LF2A
A7	2	ASSEMBLY, TIMER RELAY 12V	1005042
A9	1	DIODE CABLE ADAPTOR	1004949
A10	8	SWITCH, 2 WIRE	5801
A12	2	ELECTRICAL TERMINAL, 4 CONNECT	4-140
A15	1	HARNESS W'IRE, FLOATS LT	6A10000-004
A16	1	HARNESS W'IRE, FLOATS, RT	6A10000-005

THIS PAGE INTENTIONALLY LEFT BLANK

**SECTION 12: GEAR CONTROL**

**WIPLINE MODEL 2350 FLOAT PARTS MANUAL**

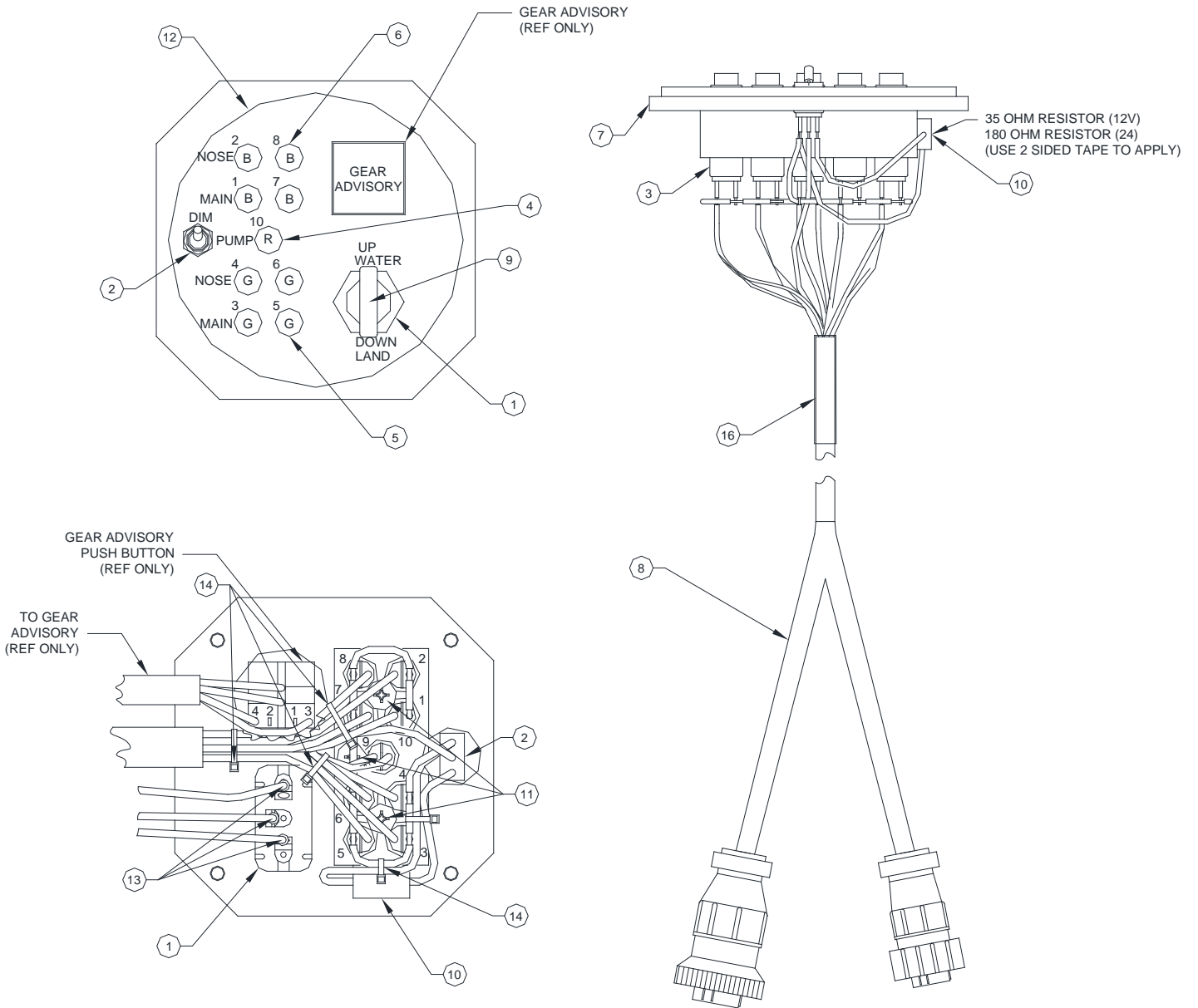

**GEAR CONTROL (ROUND)**  
**FIGURE 23**

**WIPLINE MODEL 2350 FLOAT PARTS MANUAL**

<b>ITEM</b>	<b>QTY</b>	<b>FIGURE 23: GEAR CONTROL (ROUND) PART DESCRIPTION</b>	<b>PART NO.</b>
	1	GEAR SELECTOR ASSY. ROUND (12V)	21A11000-009
	1	GEAR SELECTOR ASSY. ROUND (24V)	21A11000-019
1	1	SWITCH	8857K44
2	1	TOGGLE SWITCH, SPDT, ON-ON	A101SYCB
3	9	SOCKET	515-0012
4	1	INDICATOR LAMP, 14V, RED	507-3914-1431-600
	1	INDICATOR LAMP, 28V, RED	507-3918-1431-600
5	4	INDICATOR LAMP, 14V, GREEN	507-3914-1432-600
	4	INDICATOR LAMP, 28V, GREEN	507-3918-1432-600
6	4	INDICATOR LAMP, 14V, BLUE	507-3914-1434-600
	4	INDICATOR LAMP, 28V, BLUE	507-3918-1434-600
7	1	BLOCK, GEAR CONTROL	21A11179-001
8	1	HARNESS ASSEMBLY, GEAR SELECTOR	4A11000-008
9	1	GEAR SWITCH KNOB	21A11259-003
10	1	RESISTOR, 14V, DALE RH5 5W	RH-5-35
	1	RESISTOR, 28V, DALE RH5 5W	RH-5-180
11	3	SCREW, TRUSS HEAD, 6-32	AN526-632R8
12	1	PLACARD, ROUND2100 GEAR SELECTOR	10B3-6202
13	3	RING CONNECTOR, #6, 20 AWG, RED	R-3
14	5	CABLE TIE	PLT1M-M
15	16"	SHRINK WRAP, 3/16, WHITE	HIXR-3/16
16	3"	HEAT SHRINK TUBING	HS105-1/2-0
17	6"	WIRE, 20AWG, WHITE	22759-16-20-9

**WIPLINE MODEL 2350 FLOAT PARTS MANUAL**

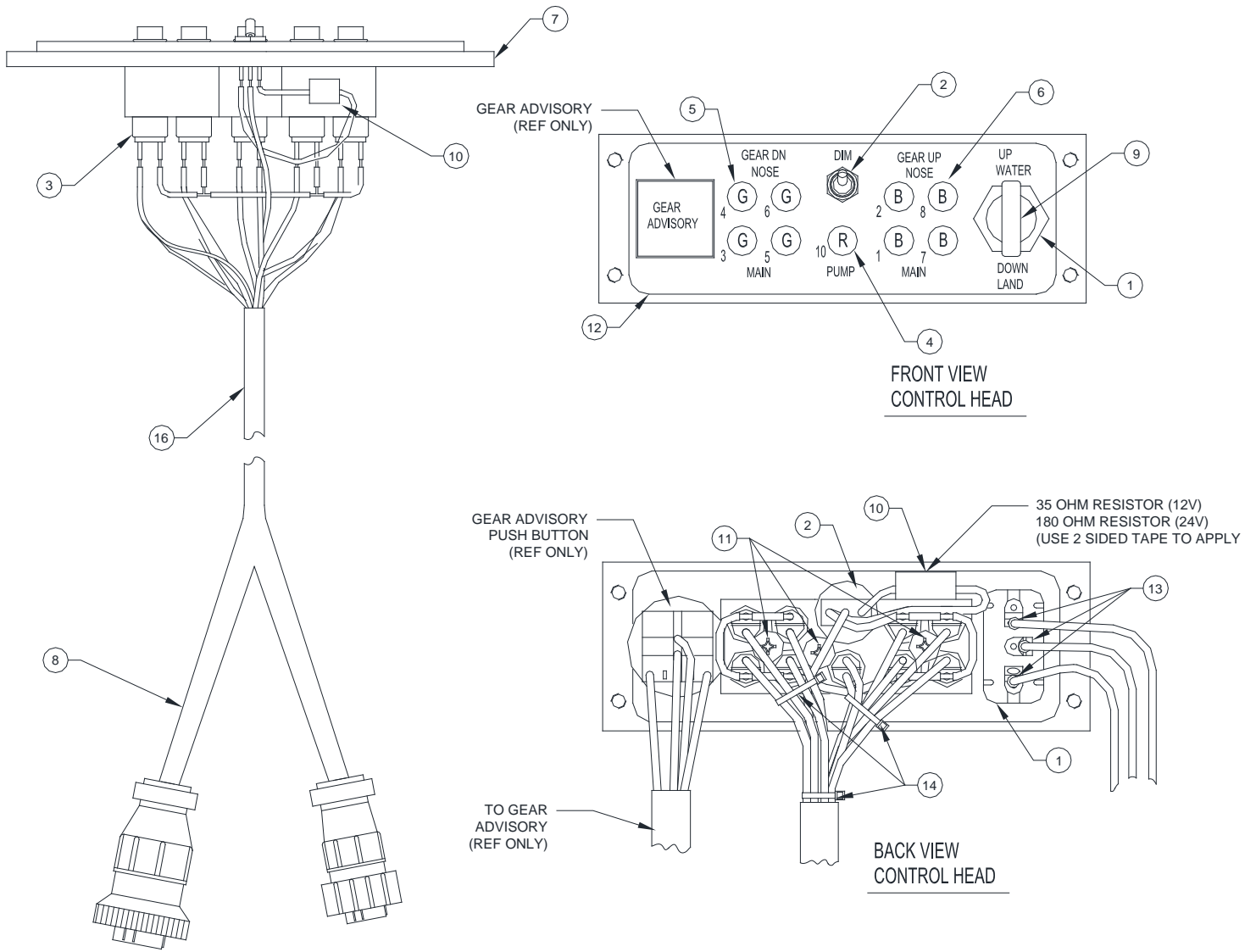

**GEAR CONTROL (RECTANGLE)  
FIGURE 24**

**WIPLINE MODEL 2350 FLOAT PARTS MANUAL**

<b>FIGURE 24: GEAR CONTROL (RECTANGLE)</b>			
<b>ITEM</b>	<b>QTY</b>	<b>PART DESCRIPTION</b>	<b>PART NO.</b>
	1	GEAR SELECTOR ASSY. RECTANGLE (12V)	21A11000-010
	1	GEAR SELECTOR ASSY. RECTANGLE (24V)	21A11000-018
1	1	SWITCH	8857K44
2	1	TOGGLE SWITCH, SPDT, ON-ON	A101SYCB
3	9	SOCKET	515-0012
4	1	INDICATOR LAMP, 14V, RED	507-3914-1431-600
	1	INDICATOR LAMP, 28V, RED	507-3918-1431-600
5	4	INDICATOR LAMP, 14V, GREEN	507-3914-1432-600
	4	INDICATOR LAMP, 28V, GREEN	507-3918-1432-600
6	4	INDICATOR LAMP, 14V, BLUE	507-3914-1434-600
	4	INDICATOR LAMP, 28V, BLUE	507-3918-1434-600
7	1	BLOCK, GEAR CONTROL	21A11179-002
8	1	HARNESS ASSEMBLY, GEAR SELECTOR	4A11000-008
9	1	GEAR SWITCH KNOB	21A11259-003
10	1	RESISTOR, 14V, DALE RH5 5W	RH-5-35
	1	RESISTOR, 28V, DALE RH5 5W	RH-5-180
11	3	SCREW, TRUSS HEAD, 6-32	AN526-632R8
12	1	PLACARD, RECTANGLE 2100 GEAR SELECTOR	10B3-6277
13	3	RING CONNECTOR, #6, 20 AWG, RED	R-3
14	3	CABLE TIE	PLT1M-M
15	16"	SHRINK WRAP, 3/16, WHITE	HIXR-3/16
16	3"	HEAT SHRINK TUBING	HS105-1/2-0
17	6"	WIRE, 20AWG, WHITE	22759-16-20-9



THIS PAGE INTENTIONALLY LEFT BLANK

**SECTION 13: HYDRAULIC PUMP**

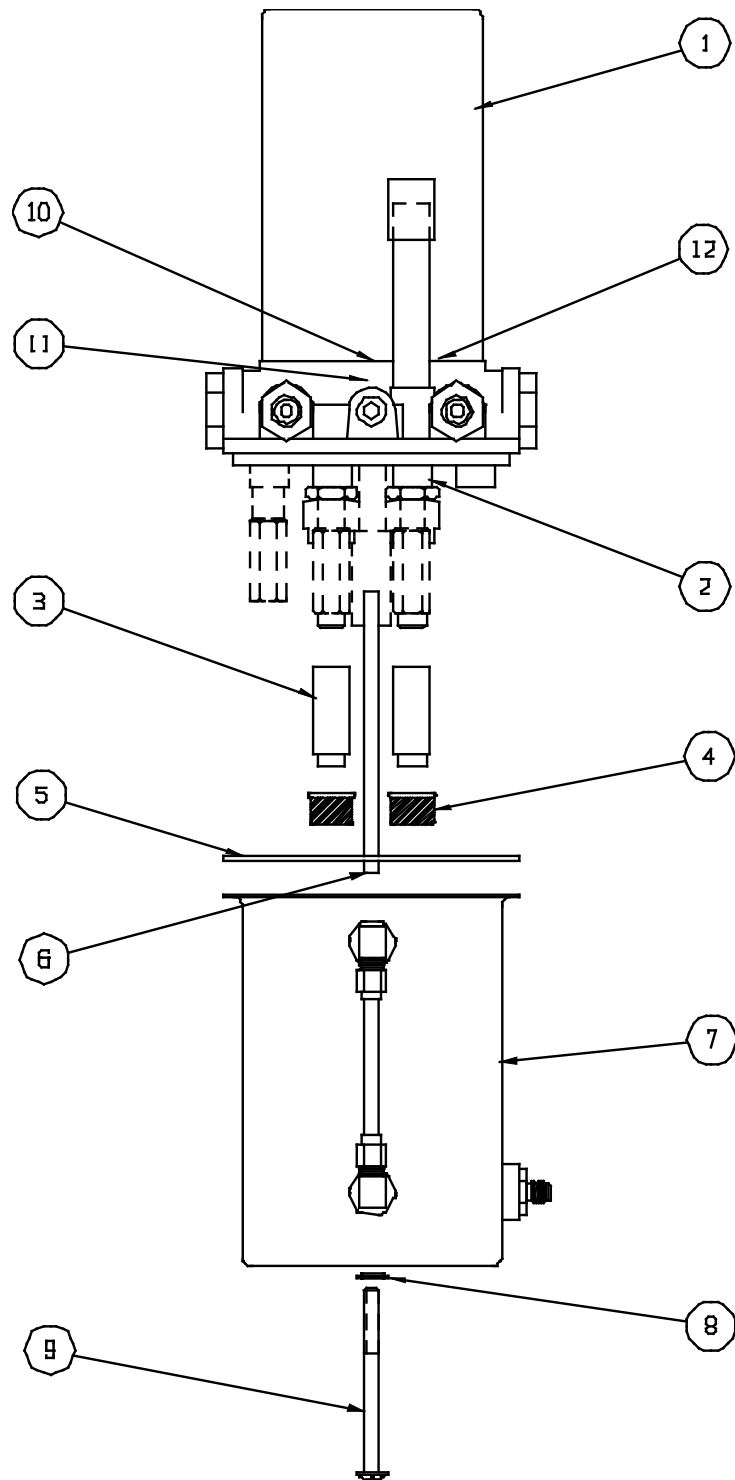

**HYDRAULIC PUMP**  
FIGURE 25

**WIPLINE MODEL 2350 FLOAT PARTS MANUAL**

<b>ITEM</b>	<b>QTY</b>	<b>FIGURE 25: HYDRAULIC PUMP PART DESCRIPTION</b>	<b>PART NO.</b>
1	1	HYDRAULIC PUMP ASSY. (12V)	21A09000-215
		HYDRAULIC PUMP ASSY. (24V)	21A09000-282
		MOTOR (12V)	640661
		MOTOR (24V)	641131
2	1	BASIC PUMP	634873
3	2	TUBE EXTENSIONS	362136
4	2	FILTER	410521
5	1	SEAL RESERVIOR	410578
6	1	RETURN TUBE	365047
7	1	RESERVIOR – GAUGE ASSY.	775260
8	1	SEAL THREAD	415067
9	1	SCREW – RESERVIOR ATTACH	409715
10	1	COUPLING – MOTOR TO PUMP	361183
11	1	SEAL – PUMP SHAFT	410512
12	1	“O” RING MOTOR TO BASE	405673

PARTS MANUAL  
FOR  
MODEL 2350 WIPLINE FLOATS  
CESSNA 172  
ITEM NUMBER: 1002168



1700 Henry Ave. – Fleming Field  
South St. Paul, MN 55075 USA  
Phone: (651) 451-1205  
Fax: (651) 451-1786  
[www.wipaire.com](http://www.wipaire.com)