



WIPLINE FLOATS • SKIS • MODIFICATIONS • AIRCRAFT SALES  
AVIONICS • INTERIOR • MAINTENANCE • PAINT REFINISHING

# WIPLINE FLOATS

## MODEL 3450

## PARTS MANUAL



## CESSNA 185

1700 Henry Ave – Fleming Field (KSGS), South St. Paul, MN 55075  
Ph: 651.451.1205 Fax: 651.457.7858  
[www.wipaire.com](http://www.wipaire.com)

THIS PAGE INTENTIONALLY LEFT BLANK

# WIPLINE MODEL 3450 FLOAT PARTS MANUAL

## TABLE OF CONTENTS

<u>SECTION</u>	<u>PAGE</u>
LOG OF REVISIONS .....	5
FLOAT PART SALES DEPT. OPERATIONS .....	6
PARTS ORDERING .....	6
DAMAGED GOODS .....	6
RETURNED PARTS.....	6
ORDER SHORTAGES .....	7
CREDIT POLICY.....	7
LIST OF ABBREVIATIONS.....	7
NEW CUSTOMER INFORMATION.....	8
HULL ASSEMBLY – AMPHIBIAN.....	9
HULL ASSEMBLY – SEAPLANE .....	19
TOP SKIN – HULL – AMPHIBIAN .....	27
TOP SKIN – HULL – SEAPLANE .....	31
WHEEL WELL – ASSEMBLY - AMPHIBIAN .....	35
ASSEMBLY, WHEEL WELL (ALUM. GEAR).....	37
EXTRUSIONS – HULL – AMPHIBIAN .....	39
EXTRUSIONS – HULL – SEAPLANE.....	41
PUMPER TUBE INSTALLATION .....	43
INSTALLATION WATER RUDDER.....	45
ASSEMBLY – NOSE GEAR RETRACTION.....	49
ASSEMBLY – NOSE GEAR – LOWER.....	53
ASSEMBLY - NOSE WHEEL (GROVE).....	55
ASSEMBLY - NOSE WHEEL (PARKER).....	57
MAIN GEAR INSTALLATION .....	59
MAIN GEAR RETRACTION.....	61

MAIN GEAR HYDRAULIC INSTALLATION .....	65
ASSEMBLY – MAIN GEAR WHEEL.....	67
ASSEMBLY, SHOCK, MAIN GEAR (ALUM. GEAR).....	71
ASSY. PIVOT, MAIN GEAR W/O WHEEL (ALUM. GEAR).....	73
ASSY. PIVOT, MAIN GEAR WITH WHEEL (ALUM. GEAR).....	75
ASSY., MAIN GEAR (ALUM. GEAR) .....	79
ASSEMBLY, ROTARY ACTUATOR, MAIN GEAR .....	83
INSTALLATION – STRUTS, WIRES AND SPREADER BARS .....	85
INSTALLATION – STEERING AND RETRACT SYSTEM .....	89
ASSEMBLY - RETRACT HANDLE .....	93
INSTALLATION – HYDRAULIC SYSTEM .....	95
ASSEMBLY – HYDRAULIC PUMP .....	97
INSTALLATION STEPS.....	101
HYDRAULIC SCHEMATIC – PUMP .....	103
ELECTRICAL SCHEMATIC .....	107
GEAR CONTROL (ROUND).....	109
GEAR CONTROL (RECTANGLE) .....	111
HYDRAULIC PUMP.....	113

**NOTE:**

**Any information not found in this manual for strut package parts and other aircraft installation items refer to the installation drawing package provided with the STC at the time of float installation. Additional drawing copies are available for purchase through the Wipaire Customer Service department.**

## Wipline Model 3000 Parts Manual

### LOG OF REVISIONS

Revision	Pages Effected	Description	Date
A	40, 51	NOSE AND MAIN GEAR RETRACTION CYLINDER P/N CHANGED.	3/20/06
B	20-26	Changed float deck P/Ns	8/3/06
C	47-49	Changed P/Ns for Main Gear Bushings Added part number and revision to all pages	11/14/06
D	53	Wheel nut p/n changed from MN21044-N5 to <b>MS21042-5</b> low profile steel nut to create greater bolt thread extension after torqueing.	8/31/07
E	ALL	Reformatted entire manual, update to Part Sales Dept page, added new warranty and customer information, added new style gear assemblies, added cable routing figure, updated multiple clerical errors and incorrect part/item callouts Added Grove Nose Wheel	11/13/12
F	4, 5, 57, 59, 84-115	Update to tube and tire P/N, added Rotary actuator assembly, washer 415067 was 359071	6/11/2013
G	3	Removed Warranty Claim Form	3/31/16

You may also look at the latest parts manual at [www.wipaire.com](http://www.wipaire.com)  
Hours: 7:00 AM – 6:00 PM, Monday through Friday

## **FLOAT PART SALES DEPT. OPERATIONS**

Hours: 7:00 AM – 6:00 PM, Monday through Friday  
Central U.S. Time

Phone: 651-306-0459

Fax: 651-306-0666

Email: [customerservice@wipaire.com](mailto:customerservice@wipaire.com)

Website: [www.wipaire.com](http://www.wipaire.com)

### **Shipping Schedule:**

In-stock orders received before 3:00 PM CST ship the same day. Orders received after this time may be assessed an AOG fee for special priority handling.

As we are primarily a manufacturer, our stocks can be rapidly depleted by production requirements. Therefore, prices and availability are subject to change at any time. It is our intent to provide courteous and prompt service of your needs. Please let us know of any problem or concerns so that changes in these procedures can be a benefit to all.

## **PARTS ORDERING**

Purchase orders should include

1. P.O. Number
2. Name of person placing order
3. Invoicing information:
  - I. Customer name – company or individual
    - i. Address
    - ii. Phone and fax number
4. Shipping information:
  - I. Address (if different from invoice address)
  - II. Method of shipment/preferred carrier
5. Aircraft model, float model and serial numbers
6. Wipaire part number; name; type, e.g. left or right; quantity
7. Payment method: VISA, MasterCard, COD (U.S. customers only). Pre-payment by check or wire transfer, open account (see credit policy section).

## **DAMAGED GOODS**

Inspect all parts upon receipt. Damages to parts in transit must be filed as a claim against the carrier.

## **RETURNED PARTS**

Written explanation of reason for return must accompany parts, including invoice number of original shipment. Shipping charges on returned parts must be prepaid or the shipment will be refused

## ORDER SHORTAGES

Check shipment against delivery slip immediately. All claims for any shortages should be made within three (3) days after order receipt.

## CREDIT POLICY

Parts will be shipped on open account, net 30 days, to Wipaire-approved credit customers only. A balance due over 60 days will result in no shipments. Wipaire, Inc reserves the right to send any order C.O.D.

## LIST OF ABBREVIATIONS

All references in this manual to LEFT and RIG HT are from the perspective of the pilot's seat with the floats fully installed and ready for floatplane operation. The following is a list of abbreviations that may appear in the description nomenclature fields of this manual:

AB	Afterbody	Inbd.	Inboard
Amphib.	Amphibious	Lg.	Large.
AR	As Required	Lt.	Left
Ass'y.	Assembly	Lwr.	Lower
Brkt.	Bracket	Opt.	Optional
Btm.	Bottom	Otbd.	Outboard
Bulk.	Bulkhead	Reinf.	Reinforcement
Ctr.	Center	Rr.	Rear
Cyl.	Cylinder	Rt.	Right
Ft.	Front	Sm.	Small
Ftg.	Fitting	SN	Serial Number
Fus.	Fuselage	Spr.	Spreader
Fwd.	Forward	Upr.	Upper
Horiz.	Horizontal	Vert.	Vertical
Hyd.	Hydraulic	W.W.	Wheel Well
		Alum.	Aluminum



## NEW CUSTOMER INFORMATION

<b>Customer Name</b>	
<b>Billing Address</b>	
<b>Shipping address</b>	
Phone Number	Fax Number
Purchasing Contact	Phone Number
E-Mail	Fax Number
Accounts Payable Contact	Phone Number
E-Mail	Fax Number
Type(s) of Floats and Skis owned or Maintained	
Models(s) of Floats and Skis owned or Maintained	
FedEx and/or UPS account number (if applicable)	

Please return to Wipaire Customer Service:

Fax 651-306-0666

Phone 651-306-0459

CustomerService@wipaire.com



WIPLINE MODEL 3450 FLOAT PARTS MANUAL

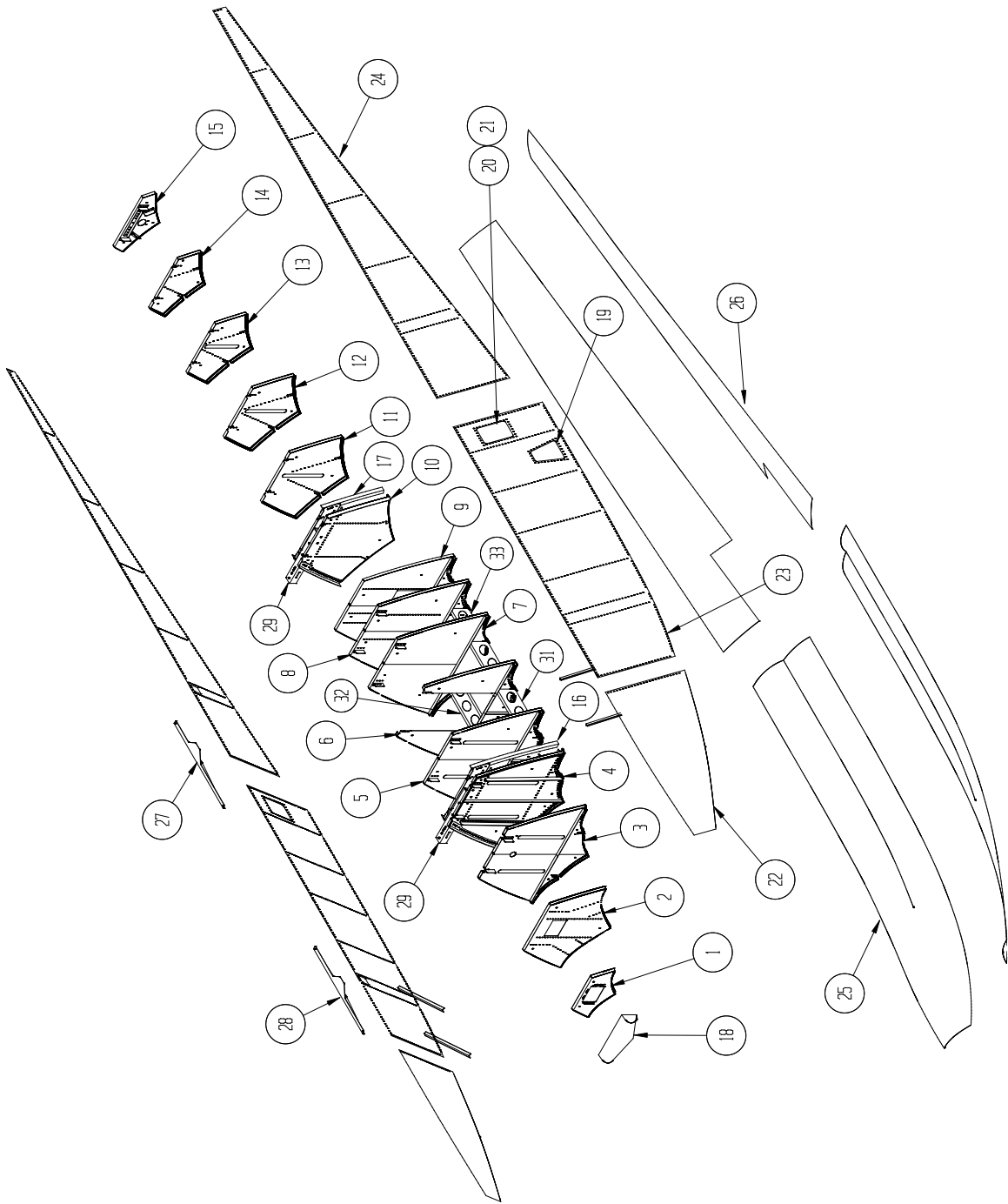

HULL ASSEMBLY – AMPHIBIAN  
FIGURE 1

## WIPLINE MODEL 3450 FLOAT PARTS MANUAL

## HULL ASSEMBLY - AMPHIBIAN, FIGURE 1

<u>REF NO.</u>	<u>NO.</u>	<u>REQ.</u>	<u>PART DESCRIPTION</u>	<u>PART NO.</u>
1	1		ASS'Y - BULKHEAD #1	30A01000-329
	1		BULKHEAD MAIN	30A01155-029
	8		NUT PLATES	MS21078-4
2	1		ASSY BULKHEAD #3	30A01000-330
	1		BULKHEAD - MAIN	30A01158-208
	1		ANGLE – NOSE BOX ATTACH	30A01326-020
	1		ANGLE – NOSE BOX ATTACH	30A01326-021
	1		ANGLE – BEND L.	30A01359-211
	1		ANGLE – BEND R.	30A01359-212
	1		ANGLE – SHORT L.	30A01359-213
	1		ANGLE – SHORT R.	30A01359-214
	2		SHIM – ANGLE	30A01163-072
3	1		ASSY BULKHEAD #4	30A01000-331
	1		BULKHEAD – MAIN L.	30A01158-209
	1		BULKHEAD – MAIN R.	30A01158-210
	1		SUPPORT – BULKHEAD LOWER	30A01158-222
	1		ANGLE L.	30A01359-223
	1		ANGLE R.	30A01359-224
	2		ANGLE	6A01359-004
4	1		ASSY BULKHEAD #5	30A01000-336
	1		BULKHEAD - MAIN L.	30A01158-211
	1		BULKHEAD - MAIN R.	30A01158-212
	1		ANGLE – SIDE L.	30A01352-037
	1		ANGLE – SIDE R.	30A01352-038
	1		PANEL – SPR. BAR	30A01155-032
	1		SUPPORT – BULKHEAD LOWER	30A01158-223
	1		ANGLE L.	30A01359-221
	1		ANGLE R.	30A01359-222
5	1		ASSY BULKHEAD #6	30A01000-332
	1		BULKHEAD – MAIN L.	30A01158-213
	1		BULKHEAD – MAIN R.	30A01158-214
	1		SUPPORT – BULKHEAD LOWER	30A01158-224
	6		ANGLE	6A01359-004

WIPLINE MODEL 3450 FLOAT PARTS MANUAL

HULL ASSEMBLY - AMPHIBIAN, FIGURE 1

<u>REF NO.</u>	<u>NO.</u>	<u>REQ.</u>	<u>PART DESCRIPTION</u>	<u>PART NO.</u>
6	1		ASSY BULKHEAD #7 L.	30A01000-333
	1		BULKHEAD – MAIN L.	30A01158-215
	1		BULKHEAD – MAIN R.	30A01158-216
	1		SUPPORT – BULKHEAD LOWER	30A01158-225
	1		ANGLE, #7 BULKHEAD	30A01326-036
	1		ANGLE, #7 BULKHEAD	30A01326-037
	2		DOUBLER, SUPPORT BULKHEAD #7	1001110
	1		BAGGAGE FLOOR	34A01008-116
7	1		ASS'Y BILKHEAD	34A01000-357
	1		BULKHEAD MAIN L	34A01158-239
	1		BULKHEAD MAIN R	34A01158-240
	1		SUPPORT BULKHEAD LOWER	34A01158-241
	6		ANGLE	6A01359-004
8	1		ASS'Y – BULKHEAD #8 L	30A01000-335
	1		BULKHEAD – MAIN L.	30A01158-217
	1		BULKHEAD – MAIN R.	30A01158-229
	1		SUPPORT – BULKHEAD LOWER	30A01158-227
	6		ANGLE	6A01359-004
	1		ASSY BULKHEAD #8 R	30A01000-334
	1		BULKHEAD – MAIN L.	30A01158-218
	1		BULKHEAD – MAIN R.	30A01158-228
	1		SUPPORT – BULKHEAD LOWER	30A01158-226
	6		ANGLE	6A01359-004
9	1		ASS'Y – BULKHEAD #9 L	30A01000-337
	1		BULKHEAD – MAIN L.	30A01158-219
	1		BULKHEAD – MAIN R.	30A01158-233
	1		SUPPORT – BULKHEAD LOWER	30A01158-231
	4		ANGLE	6A01359-004
	1		ASSY BULKHEAD #9 R	30A01000-338
	1		BULKHEAD – MAIN L.	30A01158-220
	1		BULKHEAD – MAIN R.	30A01158-232
	1		SUPPORT – BULKHEAD LOWER	30A01158-230
	4		ANGLE	6A01359-004

WIPLINE MODEL 3450 FLOAT PARTS MANUAL

HULL ASSEMBLY - AMPHIBIAN, FIGURE 1

<u>REF NO.</u>	<u>NO.</u>	<u>REQ.</u>	<u>PART DESCRIPTION</u>	<u>PART NO.</u>
10	1		ASS'Y - BULKHEAD #10	30A01000-339
	1		BULKHEAD – MAIN	30A01158-221
	1		ANGLE – SIDE L.	30A01352-035
	1		ANGLE – SIDE R.	30A01352-036
	1		PANEL – SPR. BAR	30A01155-032
	2		ANGLE	6A01359-004
11	1		ASS'Y – BULKHEAD #11	30A01000-340
	1		BULKHEAD – MAIN	30A01158-204
	1		ANGLE L.	30A01359-217
	1		ANGLE R.	30A01359-216
	2		ANGLE	6A01359-004
12	1		BULKHEAD #12	30A01000-341
	1		BULKHEAD – MAIN	30A01158-205
	1		ANGLE L.	30A01359-217
	1		ANGLE R.	30A01359-216
	2		ANGLE	6A01359-004
13	1		ASS'Y BULKHEAD #13	30A01000-342
	1		BULKHEAD - MAIN	30A01158-206
	1		ANGLE L.	30A01359-219
	1		ANGLE R.	30A01359-218
	2		ANGLE	6A01359-004
14	1		ASS'Y BULKHEAD #14	34A01000-356
	1		BULKHEAD - MAIN	34A01158-242
	1		ANGLE L	34A01359-215
	1		ANGLE R	34A01359-220
	2		ANGLE	6A01359-004
15	1		ASS'Y BULKHEAD #15	34A01000-355
	1		BULKHEAD – MAIN	34A01158-238
	4		ANGLE	6A01359-004
	1		ANGLE – UPPER	30A01359-209
	1		CASTING - PIVOT	4A01000-301

## WIPLINE MODEL 3450 FLOAT PARTS MANUAL

## HULL ASSEMBLY - AMPHIBIAN, FIGURE 1

<u>REF NO.</u>	<u>NO.</u>	<u>REQ.</u>	<u>PART DESCRIPTION</u>	<u>PART NO.</u>
16	1		ASS'Y SPR. BAR PANEL FWD	30A01000-354
	1		PANEL – SPR. BAR	30A01155-031
	1		ANGLE – SIDE L.	30A01352-039
	1		ANGLE – SIDE R.	30A01352-040
	2		ANGLE	6A01359-004
	1		BOLT	AN4-5A
	1		WASHER	NAS1149F0463P
	1		NUT	MS21044N4
17	1		ASS'Y SPR. BAR PANEL AFT	30A01000-353
	1		PANEL – SPR. BAR	30A01155-031
	1		ANGLE – SIDE L.	30A01352-033
	1		ANGLE – SIDE R.	30A01352-034
	2		ANGLE	30A01156-125
	1		BOLT	AN4-5A
	1		WASHER	NAS1149F0463P
	1		NUT	MS21044N4
18	1		NOSE BUMPER	30A01000-365
	2		ANGLE, ATTACH NOSE BUMPER	30A01359-225
19	1		STEP – BOARDING	30A01000-358
20	2		REINFORCEMENT – COVER	30A01156-144
21	2		ASSY, COVER – INSP.	21A01000-427
	2		GASKET	21A01567-012
	56		SCREW – ATTACH	AN526-632R6
22	1		SIDE SKIN ASSY. – FWD L.	30A01000-367
	1		SIDE SKIN – FWD L.	30A01148-005
	1		STIFFENER	30A01340-153
	1		STIFFENER	30A01340-133
	1		STIFFENER	30A01340-134
	1		STIFFENER	30A01340-135
	1		SIDE SKIN ASSY. – FWD R.	30A01000-367
	1		SIDE SKIN – FWD R.	30A01148-006
	1		STIFFENER	30A01340-153

WIPLINE MODEL 3450 FLOAT PARTS MANUAL

HULL ASSEMBLY - AMPHIBIAN, FIGURE 1

<u>REF NO.</u>	<u>NO.</u>	<u>REQ.</u>	<u>PART DESCRIPTION</u>	<u>PART NO.</u>
	1		STIFFENER	30A01340-133
	1		STIFFENER	30A01340-134
	1		STIFFENER	30A01340-135
	1		STIFFENER	30A01340-136
23	1		SIDE SKIN ASSY. – MIDDLE L. OUTBR'D	34A01000-369
	1		SIDE SKIN – MIDDLE L. OUTBR'D	34A01148-023
	1		STIFFENER	30A01340-137
	1		STIFFENER	30A01340-138
	1		STIFFENER	30A01340-139
	1		STIFFENER	30A01340-152
	1		SIDE SKIN ASSY. – MIDDLE L. OUTBR'D (ALUM. GEAR)	1005577
	1		SIDE SKIN – MIDDLE L. OUTBR'D (ALUM. GEAR)	1005574
	1		STIFFENER	30A01340-137
	1		STIFFENER	30A01340-138
	1		STIFFENER	30A01340-139
	1		STIFFENER	30A01340-152
	1		SIDE SKIN ASSY. – MIDDLE R. OUTBR'D	30A01000-370
	1		SIDE SKIN – MIDDLE R. OUTBR'D	34A01148-023
	1		STIFFENER	30A01340-137
	1		STIFFENER	30A01340-138
	1		STIFFENER	30A01340-139
	1		STIFFENER	30A01340-152
	1		SIDE SKIN ASSY. – MIDDLE R. OUTBR'D (ALUM. GEAR)	1005578
	1		SIDE SKIN – MIDDLE R. OUTBR'D (ALUM. GEAR)	1005574
	1		STIFFENER	30A01340-137
	1		STIFFENER	30A01340-138
	1		STIFFENER	30A01340-139
	1		STIFFENER	30A01340-152
	1		SIDE SKIN ASSY. – MIDDLE L. INBR'D	34A01000-371
	1		SIDE SKIN – MIDDLE L. INBR'D	34A01148-019
	1		STIFFENER	30A01340-137
	1		STIFFENER	30A01340-138
	2		STIFFENER	30A01340-139
	1		STIFFENER	30A01340-152
	1		BRACKET, CANOE PADDLE	1002114

WIPLINE MODEL 3450 FLOAT PARTS MANUAL

HULL ASSEMBLY - AMPHIBIAN, FIGURE 1

<u>REF NO.</u>	<u>NO.</u>	<u>REQ.</u>	<u>PART DESCRIPTION</u>	<u>PART NO.</u>
	1		CLIP	3A01503-001
	1		SIDE SKIN ASSY. – MIDDLE L. INBR'D (ALUM. GEAR)	1005575
	1		SIDE SKIN – MIDDLE L. INBR'D (ALUM. GEAR)	1005573
	1		STIFFENER	30A01340-137
	1		STIFFENER	30A01340-138
	2		STIFFENER	30A01340-139
	1		BRACKET, CANOE PADDLE	1002114
	1		CLIP	3A01503-001
	1		SIDE SKIN ASSY. – MIDDLE R. INBR'D	30A01000-372
	1		SIDE SKIN – MIDDLE R. INBR'D	34A01148-019
	1		STIFFENER	30A01340-137
	1		STIFFENER	30A01340-138
	2		STIFFENER	30A01340-139
	1		STIFFENER	30A01340-152
	1		BRACKET, CANOE PADDLE	1002114
	1		CLIP	3A01503-001
	1		SIDE SKIN ASSY. – MIDDLE R. INBR'D (ALUM. GEAR)	1005576
	1		SIDE SKIN – MIDDLE R. INBR'D (ALUM. GEAR)	1005573
	1		STIFFENER	30A01340-137
	1		STIFFENER	30A01340-138
	2		STIFFENER	30A01340-139
	1		STIFFENER	30A01340-152
	1		BRACKET, CANOE PADDLE	1002114
	1		CLIP	3A01503-001
24	1		SIDE SKIN ASSY.– AFT L. OUTBR'D	34A03000-373
	1		SIDE SKIN – AFT L. OUTBR'D	34A01148-025
	1		STIFFENER	30A01340-140
	1		STIFFENER	30A01340-141
	1		STIFFENER	30A01340-142
	1		STIFFENER	30A01340-143
	1		STIFFENER	30A01340-144
	1		STIFFENER	34A01340-147
	1		SIDE SKIN ASSY. – AFT R. OUTBR'D	34A03000-374
	1		SIDE SKIN – AFT R. OUTBR'D	34A01148-025
	1		STIFFENER	30A01340-140
	1		STIFFENER	30A01340-141
	1		STIFFENER	30A01340-142

WIPLINE MODEL 3450 FLOAT PARTS MANUAL

HULL ASSEMBLY - AMPHIBIAN, FIGURE 1

<u>REF NO.</u>	<u>NO.</u>	<u>REQ.</u>	<u>PART DESCRIPTION</u>	<u>PART NO.</u>
	1		STIFFENER	30A01340-143
	1		STIFFENER	30A01340-144
	1		STIFFENER	34A01340-147
	1		SIDE SKIN ASSY. – AFT L. INBR'D	34A01000-375
	1		SIDE SKIN – AFT L. INBR'D	34A01148-021
	1		STIFFENER	30A01340-140
	1		STIFFENER	30A01340-141
	1		STIFFENER	30A01340-142
	1		STIFFENER	30A01340-143
	1		STIFFENER	30A01340-144
	1		STIFFENER	34A01340-147
	1		SIDE SKIN ASSY. – AFT R. INBR'D	34A01000-376
	1		SIDE SKIN – AFT R. INBR'D	34A01148-021
	1		STIFFENER	30A01340-140
	1		STIFFENER	30A01340-141
	1		STIFFENER	30A01340-142
	1		STIFFENER	30A01340-143
	1		STIFFENER	30A01340-144
	1		STIFFENER	34A01340-147
25	1		BOTTOM SKIN FWD L.	30A01151-103
	1		BOTTOM SKIN FWD R.	30A01151-102
	2		BOTTOM SKIN SPLICE – AFT	34A01150-145
26	1		BOTTOM SKIN AFTERBODY L.	34A01148-039
	1		BOTTOM SKIN AFTERBODY R.	34A01148-040
27	1		DOUBLER – GUNWALL AFT L.	34A01162-054
	1		DOUBLER – GUNWALL AFT R.	34A01162-055
28	1		DOUBLER – GUNWALL FWD L.	30A01162-045
	1		DOUBLER – GUNWALL FWD R.	30A01162-046
29	1		TUBE – SPR. BAR MOUNTING R.	30A03319-001
	1		TUBE – SPR. BAR MOUNTING L.	30A03319-002
	6		BOLT	AN5-24A
	6		WASHER	NAS1149D0532J
	12		WASHER	NAS1149D0563J



WIPLINE MODEL 3450 FLOAT PARTS MANUAL

HULL ASSEMBLY - AMPHIBIAN, FIGURE 1

<u>REF NO.</u>	<u>NO.</u>	<u>REQ.</u>	<u>PART DESCRIPTION</u>	<u>PART NO.</u>
	6		NUT	MS21044N5
30	1		GUNWALL CAP (OUTBRD L) (NOT SHOWN)	34A01162-049
	1		GUNWALL CAP (OUTBRD R) (NOT SHOWN)	34A01162-050
31	2		BAGGAGE REINFORCEMENT	34A01005-385
	4		ANGLE	34A01340-173
	4		ANGLE	34A01340-174
32	2		BAGGAGE REINFORCEMENT	34A01005-384
	4		ANGLE	34A01340-173
	4		ANGLE	34A01340-174
33	2		BAGGAGE REINFORCEMENT	34A01005-383
	4		ANGLE	34A01340-173
	4		ANGLE	34A01340-174

THIS PAGE INTENTIONALLY LEFT BLANK

WIPLINE MODEL 3450 FLOAT PARTS MANUAL

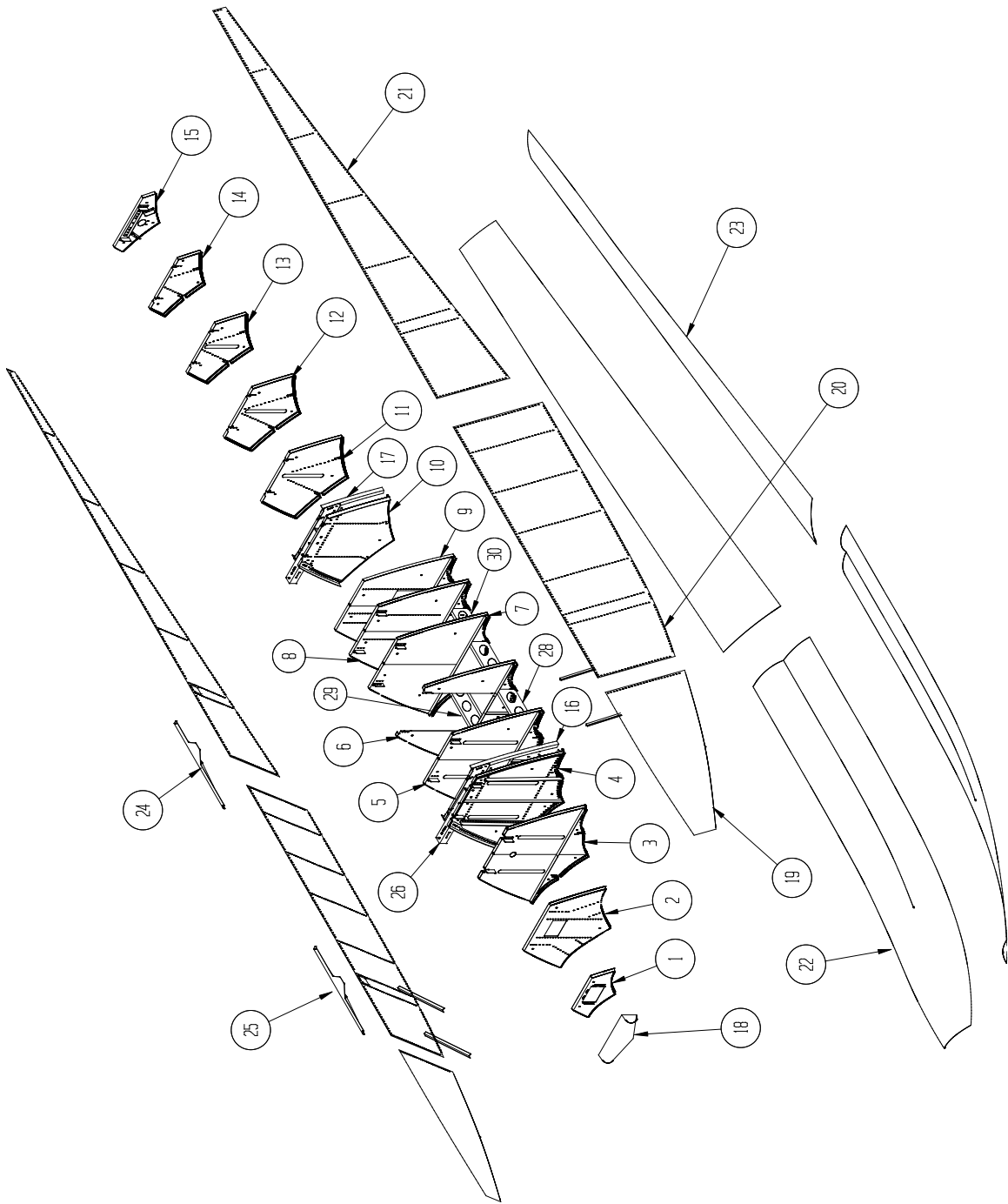

HULL ASSEMBLY – SEAPLANE  
FIGURE 2

## WIPLINE MODEL 3450 FLOAT PARTS MANUAL

## HULL ASSEMBLY - SEAPLANE, FIGURE 2

<u>REF NO.</u>	<u>NO.</u>	<u>REQ.</u>	<u>PART DESCRIPTION</u>	<u>PART NO.</u>
1	1		ASS'Y - BULKHEAD #1	30A01000-329
	1		BULKHEAD MAIN	30A01155-029
	1		COVER – BULKHEAD	30S01158-263
	1		NUT PLATES	MS21078-4
2	1		ASSY BULKHEAD #3	30A01000-330
	1		BULKHEAD - MAIN	30A01158-208
	1		ANGLE – NOSE BOX ATTACH	30A01326-020
	1		ANGLE – NOSE BOX ATTACH	30A01326-021
	1		ANGLE – BEND L.	30A01359-211
	1		ANGLE – BEND R.	30A01359-212
	1		ANGLE – SHORT L.	30A01359-213
	1		ANGLE – SHORT R.	30A01359-214
	2		SHIM – ANGLE	30A01163-072
	1		COVER – BULKHEAD	30S01158-264
3	1		ASSY BULKHEAD #4	30A01000-331
	1		BULKHEAD – MAIN L.	30A01158-209
	1		BULKHEAD – MAIN R.	30A01158-210
	1		SUPPORT – BULKHEAD LOWER	30A01158-222
	1		ANGLE L.	30A01359-223
	1		ANGLE R.	30A01359-224
	2		ANGLE	6A01359-004
4	1		ASSY BULKHEAD #5	30A01000-336
	1		BULKHEAD - MAIN L.	30A01158-211
	1		BULKHEAD - MAIN R.	30A01158-212
	1		ANGLE – SIDE L.	30A01352-037
	1		ANGLE – SIDE R.	30A01352-038
	1		PANEL – SPR. BAR	30A01155-032
	1		SUPPORT – BULKHEAD LOWER	30A01158-223
	1		ANGLE L.	30A01359-221
	1		ANGLE R.	30A01359-222
	2		ANGLE	6A01359-004
5	1		ASSY BULKHEAD #6	30A01000-332

WIPLINE MODEL 3450 FLOAT PARTS MANUAL

HULL ASSEMBLY - SEAPLANE, FIGURE 2

<u>REF NO.</u>	<u>NO.</u>	<u>REQ.</u>	<u>PART DESCRIPTION</u>	<u>PART NO.</u>
	1		BULKHEAD – MAIN L.	30A01158-213
	1		BULKHEAD – MAIN R.	30A01158-214
	1		SUPPORT – BULKHEAD LOWER	30A01158-224
	6		ANGLE	6A01359-004
6	1		ASSY BULKHEAD #7 L.	30A01000-333
	1		BULKHEAD – MAIN L.	30A01158-215
	1		BULKHEAD – MAIN R.	30A01158-216
	1		SUPPORT – BULKHEAD LOWER	30A01158-225
	4		ANGLE	6A01359-004
	1		BAGGAGE FLOOR	34A01008-116
	1		ANGLE	30A01326-036
	1		ANGLE	30A01326-037
	1		DOUBLER	1001110
7	1		ASS'Y BULKHEAD	34A01000-357
	1		BULKHEAD - MAIN L	34A01158-239
	1		BULKHEAD - MAIN R	34A01158-240
	1		SUPPORT BULKHEAD – LOWER	34A01158-241
	6		ANGLE	6A01359-004
8	1		ASS'Y – BULKHEAD #8 L	30A01000-335
	1		BULKHEAD – MAIN L.	30A01158-217
	1		BULKHEAD – MAIN R.	30A01158-229
	1		SUPPORT – BULKHEAD LOWER	30A01158-227
	6		ANGLE	6A01359-004
	1		ASSY BULKHEAD #8 R	30A01000-334
	1		BULKHEAD – MAIN L.	30A01158-218
	1		BULKHEAD – MAIN R.	30A01158-228
	1		SUPPORT – BULKHEAD LOWER	30A01158-226
	6		ANGLE	6A01359-004
9	1		ASS'Y – BULKHEAD #9	30S01000-407
	1		BULKHEAD – MAIN L.	34A01158-239
	1		BULKHEAD – MAIN R.	34A01158-240
	1		SUPPORT – BULKHEAD LOWER	34A01158-241

## WIPLINE MODEL 3450 FLOAT PARTS MANUAL

## HULL ASSEMBLY - SEAPLANE, FIGURE 2

<u>REF NO.</u>	<u>NO.</u>	<u>REQ.</u>	<u>PART DESCRIPTION</u>	<u>PART NO.</u>
	4		ANGLE	6A01359-004
	1		ANGLE	34S01158-258
	1		ANGLE	34S01158-259
	2		DOUBLER	4S01158-098
10	1		ASS'Y - BULKHEAD #10	30S01000-408
	1		BULKHEAD - MAIN	30A01158-221
	1		ANGLE - SIDE L.	30A01352-035
	1		ANGLE - SIDE R.	30A01352-036
	1		PANEL - SPR. BAR	30A01155-032
	4		ANGLE	6A01359-004
	2		ANGLE	30S01340-180
11	1		ASS'Y - BULKHEAD #11	30A01000-340
	1		BULKHEAD - MAIN	30A01158-204
	1		ANGLE L.	30A01359-217
	1		ANGLE R.	30A01359-216
	2		ANGLE	6A01359-004
12	1		BULKHEAD #12	30A01000-341
	1		BULKHEAD - MAIN	30A01158-205
	1		ANGLE L.	30A01359-217
	1		ANGLE R.	30A01359-216
	2		ANGLE	6A01359-004
13	1		ASS'Y BULKHEAD #13	30A01000-342
	1		BULKHEAD - MAIN	30A01158-206
	1		ANGLE L.	30A01359-219
	1		ANGLE R.	30A01359-218
	2		ANGLE	6A01359-004
14	1		ASS'Y BULKHEAD #15	34A01000-356
	1		BULKHEAD - MAIN	34A01158-242
	1		ANGLE UPPER	34A01359-215
	1		ANGLE LOWER	34A01359-220

## WIPLINE MODEL 3450 FLOAT PARTS MANUAL

## HULL ASSEMBLY - SEAPLANE, FIGURE 2

<u>REF NO.</u>	<u>NO.</u>	<u>REQ.</u>	<u>PART DESCRIPTION</u>	<u>PART NO.</u>
	2		ANGLE	6A01359-004
15	1		ASS'Y BULKHEAD #16	34A01000-355
	1		BULKHEAD – MAIN	34A01158-238
	4		ANGLE	6A01359-004
	1		ANGLE – UPPER	30A01359-209
	1		CASTING - PIVOT	4A01000-301
16	1		ASS'Y SPR. BAR PANEL FWD	30A01000-354
	1		PANEL – SPR. BAR	30A01155-031
	1		ANGLE – SIDE L.	30A01352-039
	1		ANGLE – SIDE R.	30A01352-040
	2		ANGLE	6A01359-004
	1		BOLT	AN4-5A
	1		WASHER	NAS1149F0463P
	1		NUT	MS21044N4
17	1		ASS'Y SPR. BAR PANEL AFT	30A01000-353
	1		PANEL – SPR. BAR	30A01155-031
	1		ANGLE – SIDE L.	30A01352-033
	1		ANGLE – SIDE R.	30A01352-034
	2		ANGLE	30A01156-125
	1		BOLT	AN4-5A
	1		WASHER	NAS1149F0463P
	1		NUT	MS21044N4
18	1		NOSE BUMPER	30S01739-001
	1		ANGLE	30S01326-034
	2		SCREW	AN526-1032R10
19	1		SIDE SKIN ASSY. – FWD L.	30A01000-367
	1		SIDE SKIN – FWD L.	30A01148-005
	1		STIFFENER	30A01340-153
	1		STIFFENER	30A01340-133
	1		STIFFENER	30A01340-134
	1		STIFFENER	30A01340-135

## WIPLINE MODEL 3450 FLOAT PARTS MANUAL

## HULL ASSEMBLY - SEAPLANE, FIGURE 2

<u>REF NO.</u>	<u>NO.</u>	<u>REQ.</u>	<u>PART DESCRIPTION</u>	<u>PART NO.</u>
	1		SIDE SKIN ASSY. – FWD R.	30A01000-367
	1		SIDE SKIN – FWD R.	30A01148-006
	1		STIFFENER	30A01340-153
	1		STIFFENER	30A01340-133
	1		STIFFENER	30A01340-134
	1		STIFFENER	30A01340-135
	1		STIFFENER	30A01340-136
20	1		SKIN ASSY. – MIDDLE L. OUTBR'D	34A01000-369
	1		SIDE SKIN – MIDDLE L. OUTBR'D	34A01148-023
	1		STIFFENER	30A01340-137
	1		STIFFENER	30A01340-138
	1		STIFFENER	30A01340-139
	1		STIFFENER	30A01340-152
	1		SIDE SKIN ASSY. – MIDDLE R. OUTBR'D	30A01000-370
	1		SIDE SKIN – MIDDLE R. OUTBR'D	34A01148-023
	1		STIFFENER	30A01340-137
	1		STIFFENER	30A01340-138
	1		STIFFENER	30A01340-139
	1		STIFFENER	30A01340-152
	1		SIDE SKIN ASSY. – MIDDLE L. INBR'D	34A01000-371
	1		SIDE SKIN – MIDDLE L. INBR'D	34A01148-019
	1		STIFFENER	30A01340-137
	1		STIFFENER	30A01340-138
	2		STIFFENER	30A01340-139
	1		STIFFENER	30A01340-152
	1		SIDE SKIN ASSY. – MIDDLE R. INBR'D	30A01000-372
	1		SIDE SKIN – MIDDLE R. INBR'D	34A01148-019
	1		STIFFENER	30A01340-137
	1		STIFFENER	30A01340-138
	2		STIFFENER	30A01340-139
	1		STIFFENER	30A01340-152
21	1		SIDE SKIN ASSY.– AFT L. OUTBR'D	34A03000-373
	1		SIDE SKIN – AFT L. OUTBR'D	34A01148-025
	1		STIFFENER	30A01340-140



## WIPLINE MODEL 3450 FLOAT PARTS MANUAL

## HULL ASSEMBLY - SEAPLANE, FIGURE 2

<u>REF NO.</u>	<u>NO.</u>	<u>REQ.</u>	<u>PART DESCRIPTION</u>	<u>PART NO.</u>
	1		STIFFENER	30A01340-141
	1		STIFFENER	30A01340-142
	1		STIFFENER	30A01340-143
	1		STIFFENER	30A01340-144
	1		STIFFENER	34A01340-147
	1		SIDE SKIN ASSY. – AFT R. OUTBR'D	34A03000-374
	1		SIDE SKIN – AFT R. OUTBR'D	34A01148-025
	1		STIFFENER	30A01340-140
	1		STIFFENER	30A01340-141
	1		STIFFENER	30A01340-142
	1		STIFFENER	30A01340-143
	1		STIFFENER	30A01340-144
	1		STIFFENER	34A01340-147
	1		SIDE SKIN ASSY. – AFT L. INBR'D	34A01000-375
	1		SIDE SKIN – AFT L. INBR'D	34A01148-021
	1		STIFFENER	30A01340-140
	1		STIFFENER	30A01340-141
	1		STIFFENER	30A01340-142
	1		STIFFENER	30A01340-143
	1		STIFFENER	30A01340-144
	1		STIFFENER	34A01340-147
	1		SIDE SKIN ASSY. – AFT R. INBR'D	34A01000-376
	1		SIDE SKIN – AFT R. INBR'D	34A01148-021
	1		STIFFENER	30A01340-140
	1		STIFFENER	30A01340-141
	1		STIFFENER	30A01340-142
	1		STIFFENER	30A01340-143
	1		STIFFENER	30A01340-144
	1		STIFFENER	34A01340-147
22	1		BOTTOM SKIN FWD L.	30A01151-103
	1		BOTTOM SKIN FWD R.	30A01151-102
	2		BOTTOM SKIN SPLICE – AFT	34A01150-145
23	1		BOTTOM SKIN AFTERBODY L.	34S01148-041
	1		BOTTOM SKIN AFTERBODY R.	34S01148-042

WIPLINE MODEL 3450 FLOAT PARTS MANUAL

HULL ASSEMBLY - SEAPLANE, FIGURE 2

<u>REF NO.</u>	<u>NO.</u>	<u>REQ.</u>	<u>PART DESCRIPTION</u>	<u>PART NO.</u>
24	1		DOUBLER – GUNWALL AFT L.	34A01162-054
	1		DOUBLER – GUNWALL AFT R.	34A01162-055
25	1		DOUBLER – GUNWALL FWD L.	30A01162-045
	1		DOUBLER – GUNWALL FWD R.	30A01162-046
26	1		TUBE – SPR. BAR MOUNTING R.	30A03319-001
	1		TUBE – SPR. BAR MOUNTING L.	30A03319-002
	6		BOLT	AN5-24A
	6		WASHER	NAS1149D0532J
	12		WASHER	NAS1149D0563J
	6		NUT	MS21044N5
27	1		GUNWALL CAP (OUTBOARD L)	34A01162-049
	1		GUNWALL CAP (OUTBOARD R) (NOT SHOWN)	34A01162-050
28	2		BAGGAGE REINFORCEMENT	34A01005-385
	4		ANGLE	34A01340-173
	4		ANGLE	34A01340-174
29	2		BAGGAGE REINFORCEMENT	34A01005-384
	4		ANGLE	34A01340-173
	4		ANGLE	34A01340-174
30	2		BAGGAGE REINFORCEMENT	34A01005-383
	4		ANGLE	34A01340-173
	4		ANGLE	34A01340-174

WIPLINE MODEL 3450 FLOAT PARTS MANUAL

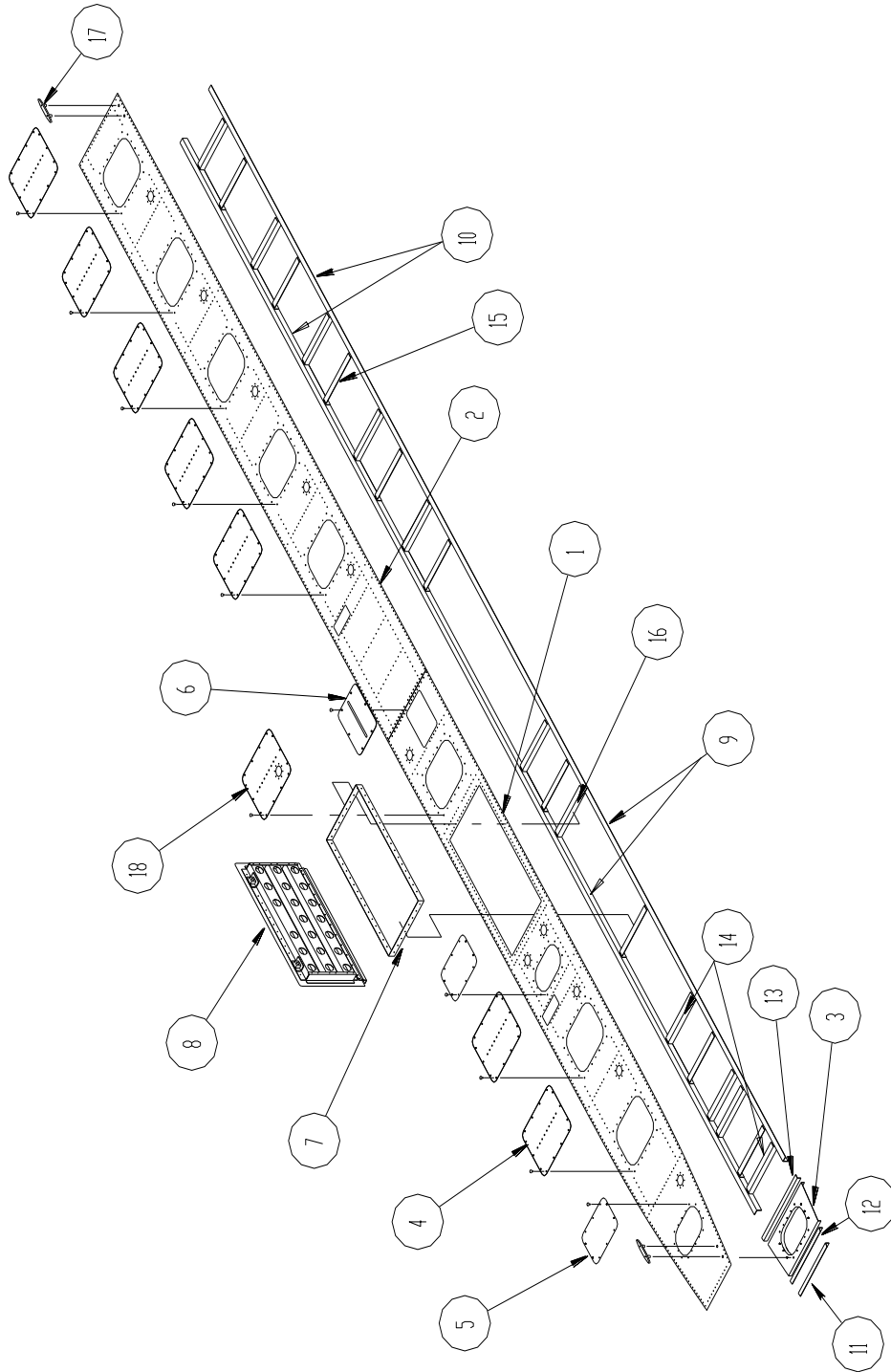

TOP SKIN – HULL – AMPHIBIAN  
FIGURE 3

## WIPLINE MODEL 3450 FLOAT PARTS MANUAL

## TOP SKIN - HULL – AMPHIBIAN, FIGURE 3

<u>REF NO.</u>	<u>NO.</u>	<u>REQ.</u>	<u>PART DESCRIPTION</u>	<u>PART NO.</u>
1	1		SKIN – FWD SECTION L.	34A01148-015
	1		SKIN – FWD SECTION L. (ALUM. GEAR)	1005565
	1		SKIN – FWD SECTION R.	34A01148-016
	1		SKIN – FWD SECTION R. (ALUM. GEAR)	1005566
2	1		SKIN – AFT SECTION L.	34A01148-017
	1		SKIN – AFT SECTION R.	34A01148-018
3	1		SUPPORT – INSP. COVER – SMALL	21A01002-131
	A/R		NUT – TINNERMAN & INSULATOR	1002481
4	7		INSP. COVER – LARGE - W/ ANGLE & GASKETS	21A01000-258
	A/R		SCREW – ATTACH	SS TATP 8 X 5/8
	7		SEAL – GASKET ONLY	1001437
5	2		INSP. COVER – SMALL & GASKETS	21A01000-284
	A/R		SCREW – ATTACH	SS TATP 8 X 5/8
	2		SEAL – GASKET ONLY	1001728
6	1		COVER – GEAR INDICATOR L.	30A01002-203
	1		COVER – GEAR INDICATOR R.	30A01002-202
	1		PLACARD – DOWN - LAND	10A3-6338-1
	1		PLACARD – UP - WATER	10A3-6338-2
	2		SCREW – CAM - LOK	2600-3
	4		SCREW – CAM – LOK	1126000-5
	6		RECEPTACLE – CAM – LOK	212-12N
7	1		JAMB – BAGGAGE DOOR	30A01162-042
	1		JAMB – BAGGAGE DOOR, HINGE SIDE	1001573
8	1		ASSY – BAGGAGE DOOR	30A01000-324
	1		COVER - SKIN	30A01162-041
	1		HINGE	30A01741-006
	1		STIFFENER – DOOR	30A01004-145
	2		STIFFENER - DOOR	30A01004-144
	2		STIFFENER ENDS	4A01004-049
	2		RETAINER - LOCK	3A01206-001

WIPLINE MODEL 3450 FLOAT PARTS MANUAL

TOP SKIN - HULL – AMPHIBIAN, FIGURE 3

<u>REF NO.</u>	<u>NO.</u>	<u>REQ.</u>	<u>PART DESCRIPTION</u>	<u>PART NO.</u>
	2		LOCK PIN	3A01273-004
	2		CATCH – LATCH	3A01702-004
	2		LOCK SPRING	3A01525-003
	2		RING – OPENING	1002663
	1		SEAL – GASKET (NOT SHOWN)	1001499
	1		HINGE	30A01741-007
	1		HINGE PIN 2.04	1002186
	18		POP RIVET	01692-0410
	2		SCREW	SS 10/32 x ½ INCH
9	1		TOP RAIL – FWD L.	34A01326-031
	1		TOP RAIL – FWD R.	34A01326-032
10	1		TOP RAIL – AFT L.	34A01326-033
	1		TOP RAIL – AFT R.	34A01326-034
11	1		STIFFENER	30A01340-175
12	1		STIFFENER	30A01340-176
13	1		STIFFENER	30A01340-177
14	2		STIFFENER	30A01326-032
15	A/R		STIFFENER	30A01326-022
16	2		STIFFENER – BAGGAGE DOOR	30A01326-030
17	2		CLEAT – TIE DOWN	30A01213-007
	4		BOLT	AN4-7A
	4		WASHER	NAS1149D0463J
	4		NUT	MS21083N4
18	1		INSP. COVER – LRG. W/ ANGLE, & GASKET LEFT	30A01000-359
			INSP. COVER – LRG. W/ ANGLE, & GASKET RT.	30A01000-360
	A/R		SCREW – ATTACH	SS TATP 8 X 5/8
	1		GASKET ONLY	1001437

THIS PAGE INTENTIONALLY LEFT BLANK

WIPLINE MODEL 3450 FLOAT PARTS MANUAL

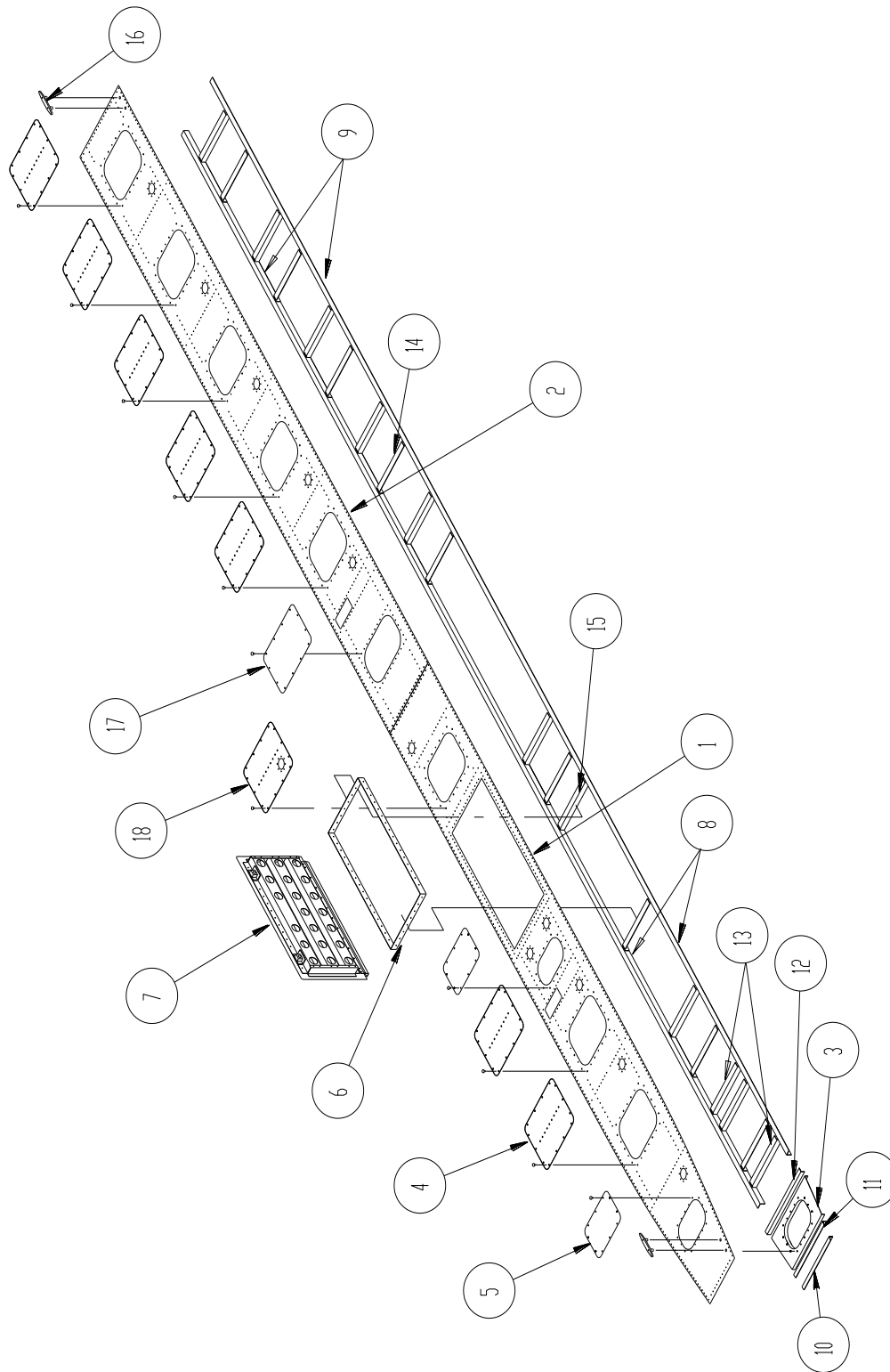

TOP SKIN – HULL – SEAPLANE  
FIGURE 4

## WIPLINE MODEL 3450 FLOAT PARTS MANUAL

## TOP SKIN - HULL – SEAPLANE, FIGURE 4

<u>REF NO.</u>	<u>NO.</u>	<u>REQ.</u>	<u>PART DESCRIPTION</u>	<u>PART NO.</u>
1	1		SKIN – FWD SECTION L.	34A01148-015
	1		SKIN – FWD SECTION R.	34A01148-016
2	1		SKIN – AFT SECTION L.	34S01148-043
	1		SKIN – AFT SECTION R.	34S01148-044
3	1		SUPPORT – INSP. COVER – SMALL	21A01002-131
	A/R		NUT – TINNEMAN & INSULATOR	1002481
4	8		INSP. COVER – LARGE - W/ ANGLE & GASKETS	21A01000-258
	A/R		SCREW – ATTACH	SS TATP 8 X 5/8
	8		SEAL – GASKET ONLY	1001437
	1		STIFFENERS – ANGLE	21A01340-103
5	2		INSP. COVER – SMALL & GASKETS	21A01000-284
	A/R		SCREW – ATTACH	SS TATP 8 X 5/8
	2		SEAL – GASKET ONLY	1001728
6	1		JAMB – BAGGAGE DOOR	30A01162-042
	1		JAMB – BAGAGE DOOR, HINGE SIDE	1002065
7	1		ASSY – BAGGAGE DOOR	30A01000-324
	1		COVER - SKIN	30A01162-041
	1		HINGE	30A01741-006
	1		HINGE	30A01740-007
	1		STIFFENER – DOOR	30A01004-145
	2		STIFFENER - DOOR	30A01004-144
	2		STIFFENER ENDS	4A01004-049
	2		RETAINER - LOCK	3A01206-001
	2		LOCK PIN	3A01273-004
	2		CATCH – LATCH	3A01702-004
	2		LOCK SPRING	3A01525-003
	2		RING – OPENING	1002663
	1		SEAL – GASKET (NOT SHOWN)	1001499
	1		HINGE PIN 2.04	1002186



WIPLINE MODEL 3450 FLOAT PARTS MANUAL

TOP SKIN - HULL – SEAPLANE, FIGURE 4

<u>REF NO.</u>	<u>NO.</u>	<u>REQ.</u>	<u>PART DESCRIPTION</u>	<u>PART NO.</u>
	18		POP RIVET	01692-0410
8	2		SCREW	SS 10/32 x ½ INCH
	1		TOP RAIL – FWD R.	34A01326-032
9	1		TOP RAIL – AFT L.	34A01326-033
	1		TOP RAIL – AFT R.	34A01326-034
10	1		STIFFENER	30A01340-175
11	1		STIFFENER	30A01340-176
12	1		STIFFENER	30A01340-177
13	2		STIFFENER	30A01326-032
14	A/R		STIFFNER	30A01326-022
15	2		STIFFENER – BAGGAGE DOOR	30A01326-030
16	2		CLEAT – TIE DOWN	30A01213-007
	4		WASHER	NAS1149D0463J
	4		NUT	MS21083N4
17	1		INSP. COVER – MED. W/ GASKET	21S01000-399
	A/R		SCREW ATTACH	SS TATP 8 X 5/8
	1		GASKET ONLY	21S01567-013
18	1		INSP. COVER – LRG. W/ ANGLE & GASKET LEFT	30A01000-360
			INSP. COVER – LRG. W/ ANGLE & GASKET RIGHT	30A01000-359
	A/R		SCREW ATTACH	SS TATP 8 X 5/8
	1		GASKET	1001437

THIS PAGE INTENTIONALLY LEFT BLANK

WIPLINE MODEL 3450 FLOAT PARTS MANUAL

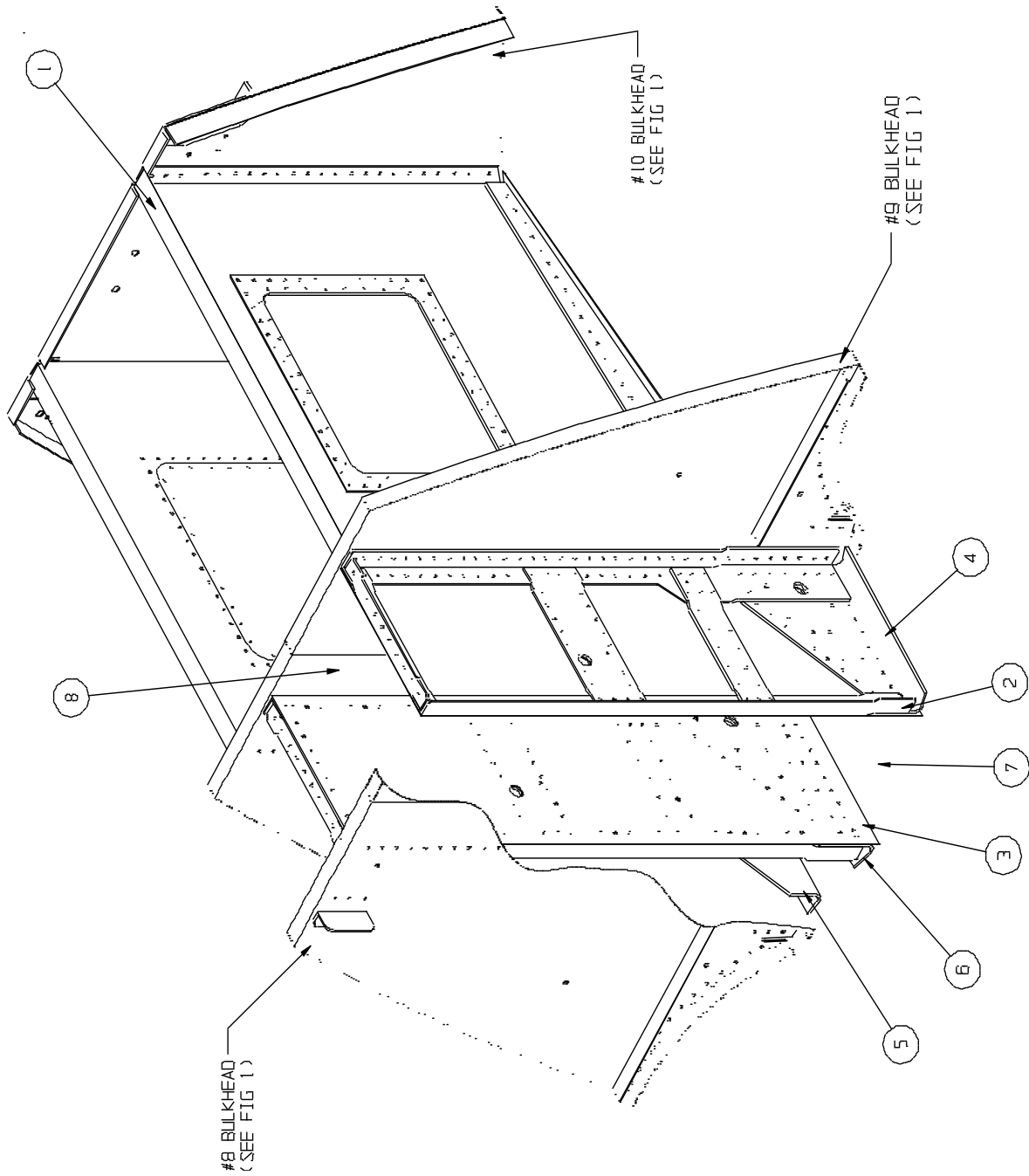

WHEEL WELL – ASSEMBLY - AMPHIBIAN  
FIGURE 5

WIPLINE MODEL 3450 FLOAT PARTS MANUAL

WHEEL WELL – ASSEMBLY – AMPHIBIAN, FIGURE 5

<u>REF NO.</u>	<u>NO.</u>	<u>PART DESCRIPTION</u>	<u>PART NO.</u>	
1	1	ASS'Y – WHEELWELL HALF L.	30A01000-349	
	1	PANEL – FORMED L.	30A01158-235	
	1	RING – COVER REINFORCEMENT	13A01156-124	
	1	COVER	21A01004-101	
	28	SCREW	AN526-632R6	
	2	1	ASS'Y – WHEELWELL HALF R.	30A01000-348
		1	PANEL – FORMED R.	30A01158-234
		1	RING – COVER REINFORCEMENT	13A01156-124
		1	COVER	21A01004-101
		28	SCREW	AN526-632R6
		2	1	ASS'Y – WHEELWELL PANEL – OUTBR'D L.
	1		ASS'Y - WHEELWELL PANEL – OUTBR'D R.	30A01000-350
	3	1	ASS'Y – WHEELWELL PANEL – INBR'D L.	30A01000-347
		1	ASS'Y - WHEELWELL PANEL – INBR'D R.	30A01000-346
4	1	CARRY-THRU STRAP OUTBR'D L.	30A01156-139	
	1	CARRY-THRU STRAP OUTBR'D R.	30A01156-142	
5	1	CARRY-THRU STRAP INBR'D L.	30A01156-141	
	1	CARRY-THRU STRAP INBR'D R.	30A01156-140	
6	1	CARRY-THRU STRAP INBR'D L.	30A01156-143	
	1	CARRY-THRU STRAP INBR'D R.	30A01156-138	
	1	ANGLE – ATTACH AFT L.	30A01156-145	
	1	ANGLE – ATTACH AFT R.	30A01156-150	
	1	SHIM	30A01160-035	
	2	ANGLE – ATTACH FWD	21A01326-015	
7	1	SAND GUARD (NOT SHOWN) L.	30A01000-287	
	1	SAND GUARD (NOT SHOWN) R.	30A01000-288	
	8	SCREW	AN526-1032R8	
	4	NUT PLATE	MS21078-3	
8	1	MUD FLAP (NOT SHOWN)	30A01569-002	
	1	REINFORCEMENT	30A01150-141	

WIPLINE MODEL 3450 FLOAT PARTS MANUAL

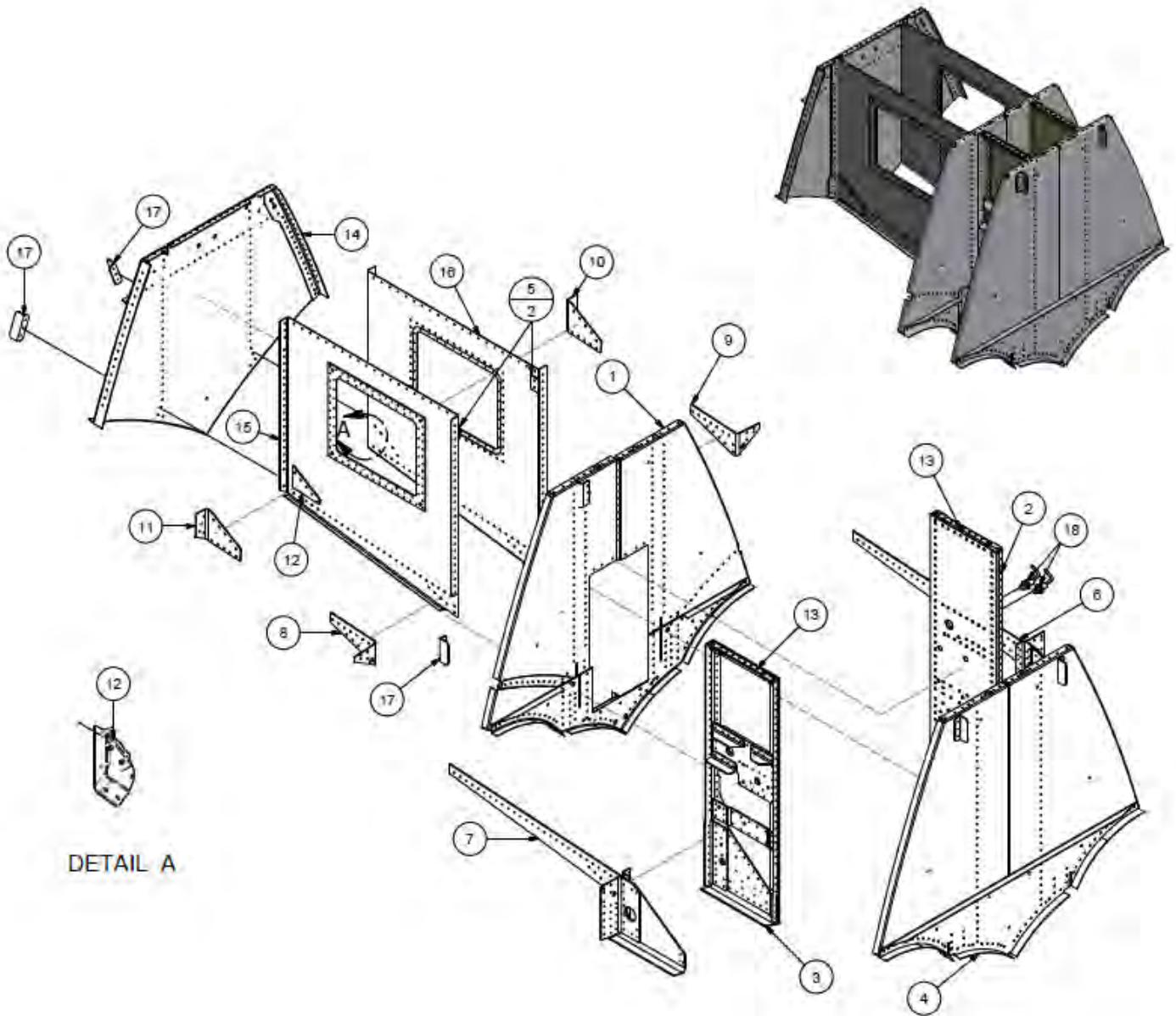

ASSEMBLY, WHEEL WELL (ALUM. GEAR)  
FIGURE 5A

WIPLINE MODEL 3450 FLOAT PARTS MANUAL

ASSEMBLY WHEEL WELL (ALUM. GEAR), FIGURE 5A

<u>REF NO.</u>	<u>NO.</u>	<u>PART DESCRIPTION</u>	<u>PART NO.</u>
1	1	ASS'Y BULKHEAD #9	1004888
2	1	ASSEMBLY, PANEL, MAIN GEAR	1004893
3	1	ASSEMBLY, PANEL, MAIN GEAR	1004894
4	1	ASSEMBLY, BULKHEAD	1004914
5	2	SPACER, ATTACH, ANGLE, TOP RAIL	1005520
6	1	ASSEMBLY, CARRY THRU STRAP, RIGHT	1005523
7	1	ASSEMBLY, CARRY THRU STRAP, LEFT	1005524
8	1	GUSSET, WHEELWELL	1005531
9	1	GUSSET, WHEEL WELL	1005532
10	1	GUSSET, WHEELWELL, REAR	1005542
11	1	GUSSET, WHEELWELL, REAR	1005543
12	2	SPACER, GUSSET, CARRY-THRU	1005550
13	2	SPACER, ANGLE, PANEL, MAIN GEAR	1005557
14	1	ASS'Y BULKHEAD #10	30A01000-339
15	1	ASSEMBLY, PANEL, SIDE, WHEEL WELL, RH	30A01000-348
16	1	ASSEMBLY, PANEL, SIDE, WHEEL WELL, LH	30A01000-349
17	4	ANGLE - SUPPORT	6A01359-004
18	2	SWITCH, PROXIMITY	1005724

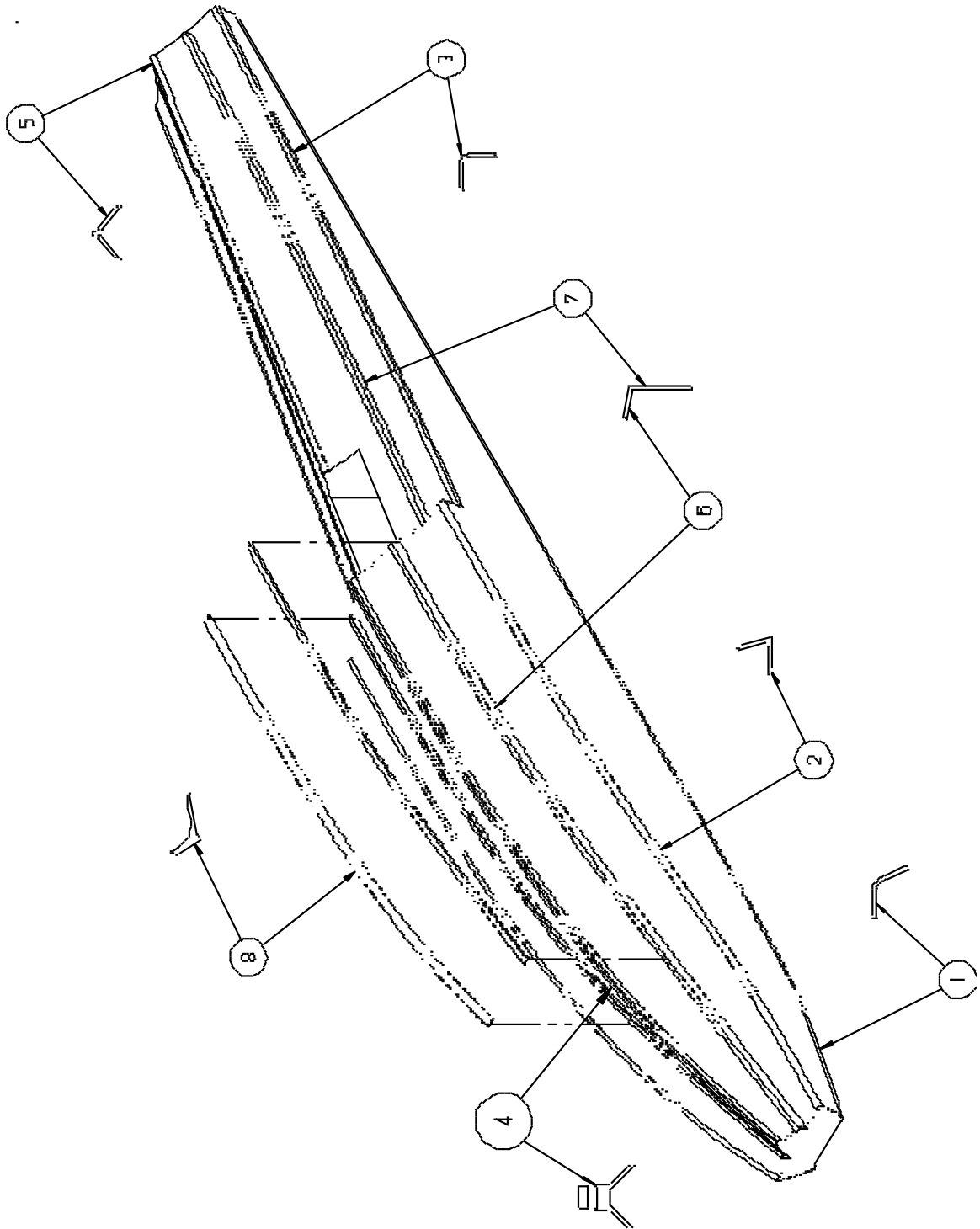

EXTRUSIONS – HULL – AMPHIBIAN  
FIGURE 6

WIPLINE MODEL 3450 FLOAT PARTS MANUAL

EXTRUSION – HULL – AMPHIBIAN, FIGURE 6

<u>REF NO.</u>	<u>NO.</u>	<u>REQ.</u>	<u>PART DESCRIPTION</u>	<u>PART NO.</u>
1	1		GUNWALL – L. INBOARD	34A01324-007
	1		GUNWALL – R. INBOARD	34A01324-008
	1		GUNWALL – L. OUTBOARD	34A01324-009
	1		GUNWALL – R. OUTBOARD	34A01324-010
2	1		CHINE - FWD L.	34A01394-145
	1		CHINE – FWD R.	34A01394-146
3	1		CHINE – AFTERBODY L.	34A01395-003
	1		CHINE – AFTERBODY R.	34A01395-004
4	1		KEEL - MAIN	34A01377-002
	1		STRIP, WEAR	3A01200-001
5	1		KEEL - AFTERBODY	34A01425-002
6	1		SISTER KEEL – FWD L.	34A01361-041
	1		SISTER KEEL – FWD R.	34A01361-042
7	1		SISTER KEEL – AFT L.	34A01361-043
	1		SISTER KEEL – AFT R.	34A01361-044
8	1		SISTER KEEL – OUTER L.	34A01342-011
	1		SISTER KEEL – OUTER R.	34A01342-012



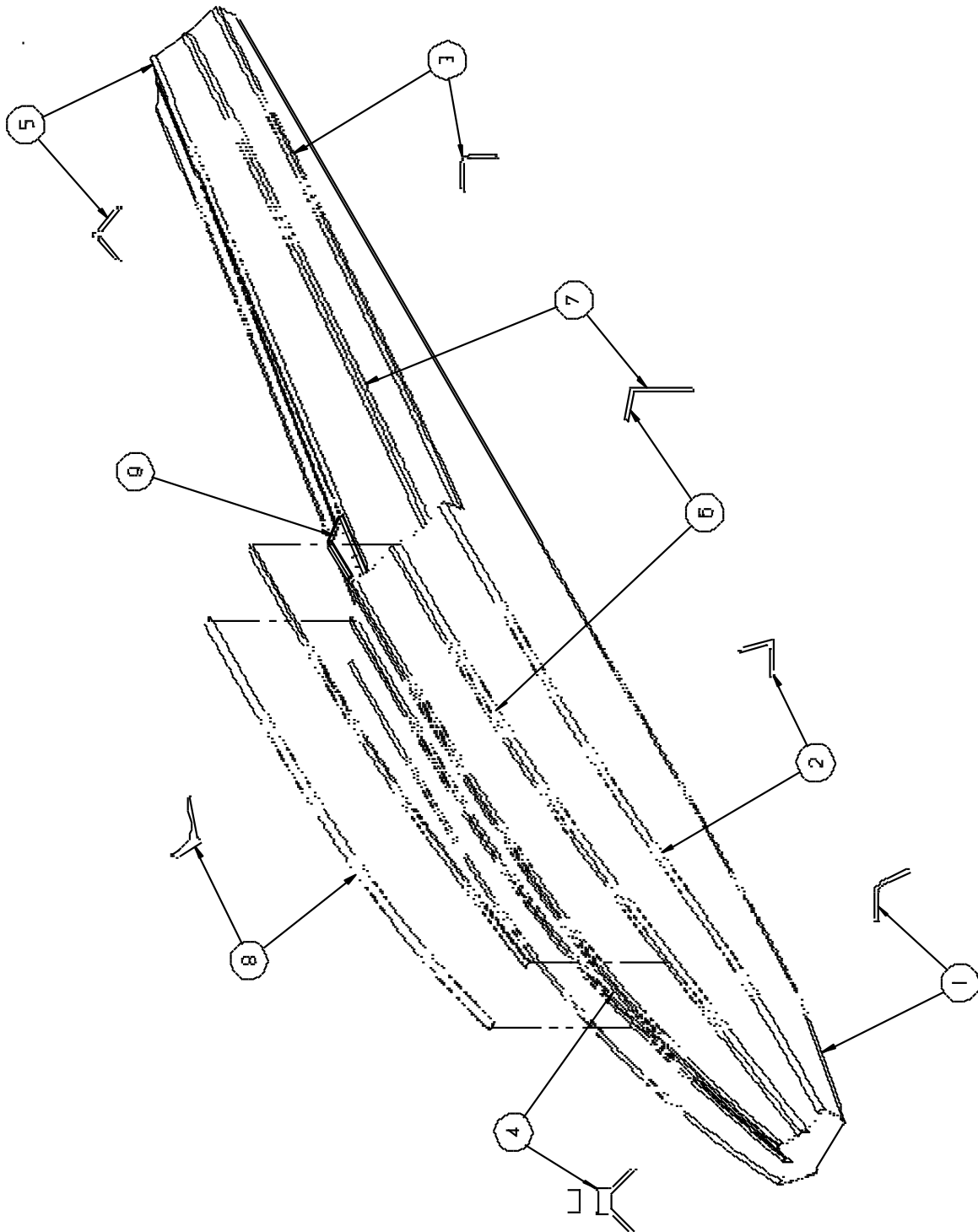

EXTRUSIONS – HULL – SEAPLANE  
FIGURE 7

WIPLINE MODEL 3450 FLOAT PARTS MANUAL

EXTRUSION – HULL – SEAPLANE, FIGURE 7

<u>REF NO.</u>	<u>NO.</u>	<u>REQ.</u>	<u>PART DESCRIPTION</u>	<u>PART NO.</u>
1	1		GUNWALL – L. INBOARD	34A01324-007
	1		GUNWALL – R. INBOARD	34A01324-008
	1		GUNWALL – L. OUTBOARD	34A01324-009
	1		GUNWALL – R. OUTBOARD	34A01324-010
2	1		CHINE - FWD L.	34A01394-145
	1		CHINE – FWD R.	34A01394-146
3	1		CHINE – AFTERBODY L.	34A01395-003
	1		CHINE – AFTERBODY R.	34A01395-004
4	1		KEEL - MAIN	34A01377-002
	1		STRIP, WEAR	3A01200-001
5	1		KEEL - AFTERBODY	34S01425-002
6	1		SISTER KEEL – FWD L.	34A01361-041
	1		SISTER KEEL – FWD R.	34A01361-042
7	1		SISTER KEEL – AFT L.	34S01361-045
	1		SISTER KEEL – AFT R.	34S01361-046
8	1		SISTER KEEL – OUTER L.	34A01342-011
	1		SISTER KEEL – OUTER R.	34A01342-012
9	1		ANGLE SUPPORT – AFTERBODY L.	30S01163-085
	1		ANGLE SUPPORT – AFTERBODY R.	30S01163-086

WIPLINE MODEL 3450 FLOAT PARTS MANUAL

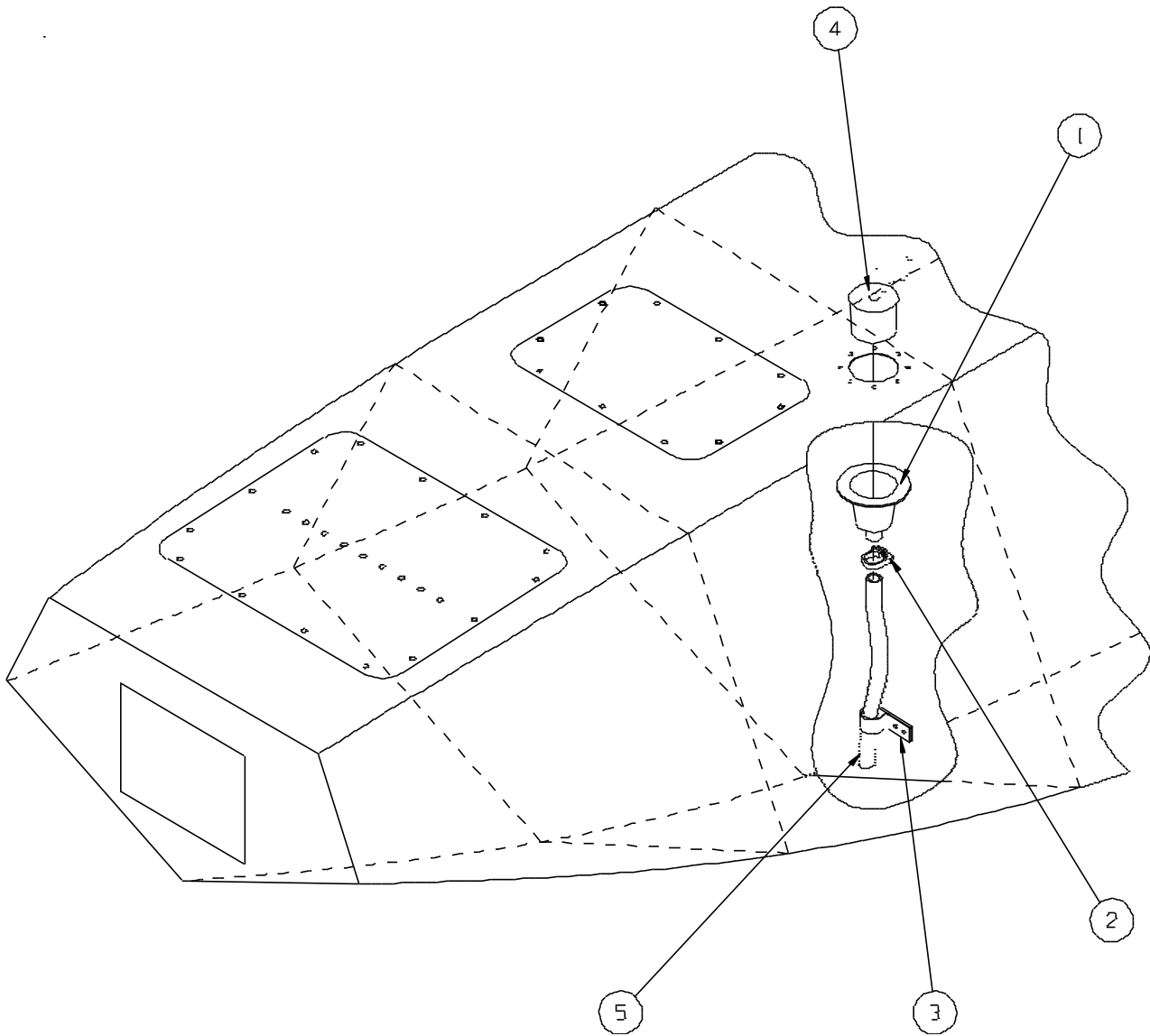

PUMPER TUBE INSTALLATION  
FIGURE 8

WIPLINE MODEL 3450 FLOAT PARTS MANUAL

PUMPER TUBE INSTALLATION, FIGURE 8

<u>REF NO.</u>	<u>NO.</u>	<u>PART DESCRIPTION</u>	<u>PART NO.</u>
1	1	CUP – PUMPOUT ALUM.	4A01749-001
	A/R	RIVETS	MS20470AD 4-4
2	1	CLAMP – UPPER END	57134
3	1	CLAMP – LOWER END	3A01158-003
4	1	STOPPER – PUMPER TUBE	2111
5	1	PUMPOUT TUBE 18.5 IN.	30A01618-064
	1	PUMPOUT TUBE 24.5	30A01618-065
	1	PUMPOUT TUBE 26.5	30A01618-066
	1	PUMPOUT TUBE 29.0	30A01618-067
	1	PUMPOUT TUBE 23.0	30A01618-068
	1	PUMPOUT TUBE 26.5	30A01618-069
	1	PUMPOUT TUBE 22.0	30A01618-070
	1	PUMPOUT TUBE 18.0	30A01618-071
	1	PUMPOUT TUBE 15.5	30A01618-072
	1	PUMPOUT TUBE 12.5	30A01618-073
	1	PUMPOUT TUBE 25.0	30A01618-074

WIPLINE MODEL 3450 FLOAT PARTS MANUAL

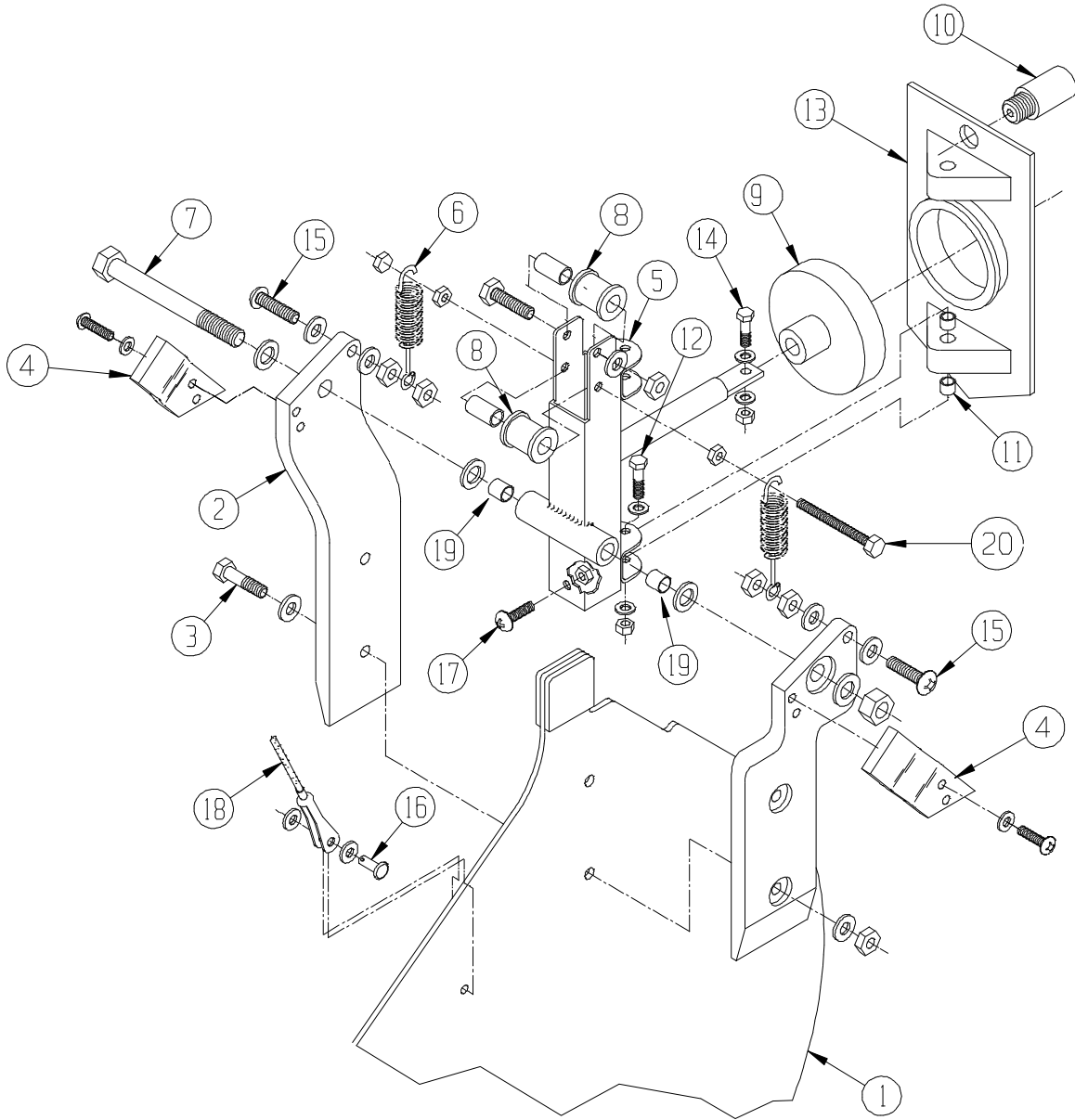

INSTALLATION WATER RUDDER  
FIGURE 9

WIPLINE MODEL 3450 FLOAT PARTS MANUAL

INSTALLATION WATER RUDDER, FIGURE 9

<u>REF NO.</u>	<u>NO.</u>	<u>REQ.</u>	<u>PART DESCRIPTION</u>	<u>PART NO.</u>
1	1		ASS'Y - BLADE	4A08000-094
	1		BLADE	4A08000-062
2	1		ARM – BLADE – L.H.	4A08197-009
	1		ARM – BLADE – R.H.	4A08197-008
3	2		BOLT – ARM ATTACH	AN4-10A
	A/R		WASHER	NAS1149D0463J
	2		NUT	NAS679A4W
4	2		RUDDER STOP - UP	4A08205-003
	4		SCREW	AN526-1032R10
	4		WASHER - LOCK	MS35333-39
5	1		ASS'Y – WATER RUDDER PIVOT	4A08000-097
6	2		SPRING - RETRACT	4A08525-004
7	1		BOLT – WATER RUDDER HINGE	AN6C34A
	A/R		WASHER	NAS1149D0663J
	1		NUT	MS21083N6
8	2		ROLLER – RETRACT CABLE - LOWER	3A08606-001
	2		BUSHING - ROLLER	3A08502-001
	2		BOLT – ROLLER (HEX HD. S.S.)	AN3C10A
	6		NUT	NAS679A3W
9	1		BOOT – WATER RUDDER	3A08650-001
10	1		GUIDE – WATER RUDDER CABLE	3A08605-001
11	4		BEARING	03DU-04
12	2		BOLT – RUDDER POST HINGE	AN3C10A
	A/R		WASHER	NAS1149D0363J

WIPLINE MODEL 3450 FLOAT PARTS MANUAL

INSTALLATION WATER RUDDER, FIGURE 9

<u>REF NO.</u>	<u>NO.</u>	<u>REQ.</u>	<u>PART DESCRIPTION</u>	<u>PART NO.</u>
	2		NUT	NAS679A3W
13	1		CASTING – PIVOT – WATER RUDDER	4A01000-301
14	1		BOLT – RUDDER TO ARM ATTACH	AN3-6A
	A/R		WASHER	NAS1149D0363J
	1		NUT	MS21044N3
15	2		SCREW – SPRING ATTACH	AN526-428R16
	A/R		WASHER	NAS1149D0363J
	4		NUT	NAS679A3W
16	1		PIN - CLEVIS	MS20392-2C11
	A/R		WASHER	NAS1149D0316J
	1		COTTER PIN	MS24665-151
17	1		SCREW – RUDDER STOP - DOWN	AN526-1032R16
	1		NUT	NAS679A3W
18	1		ASS'Y – CABLE – RETRACT	34A08000-161
19	4		BEARING – NYLINER (NOTE 4)	06DU08
20	1		BOLT	1032 X 2" SS

THIS PAGE INTENTIONALLY LEFT BLANK



WIPLINE MODEL 3450 FLOAT PARTS MANUAL

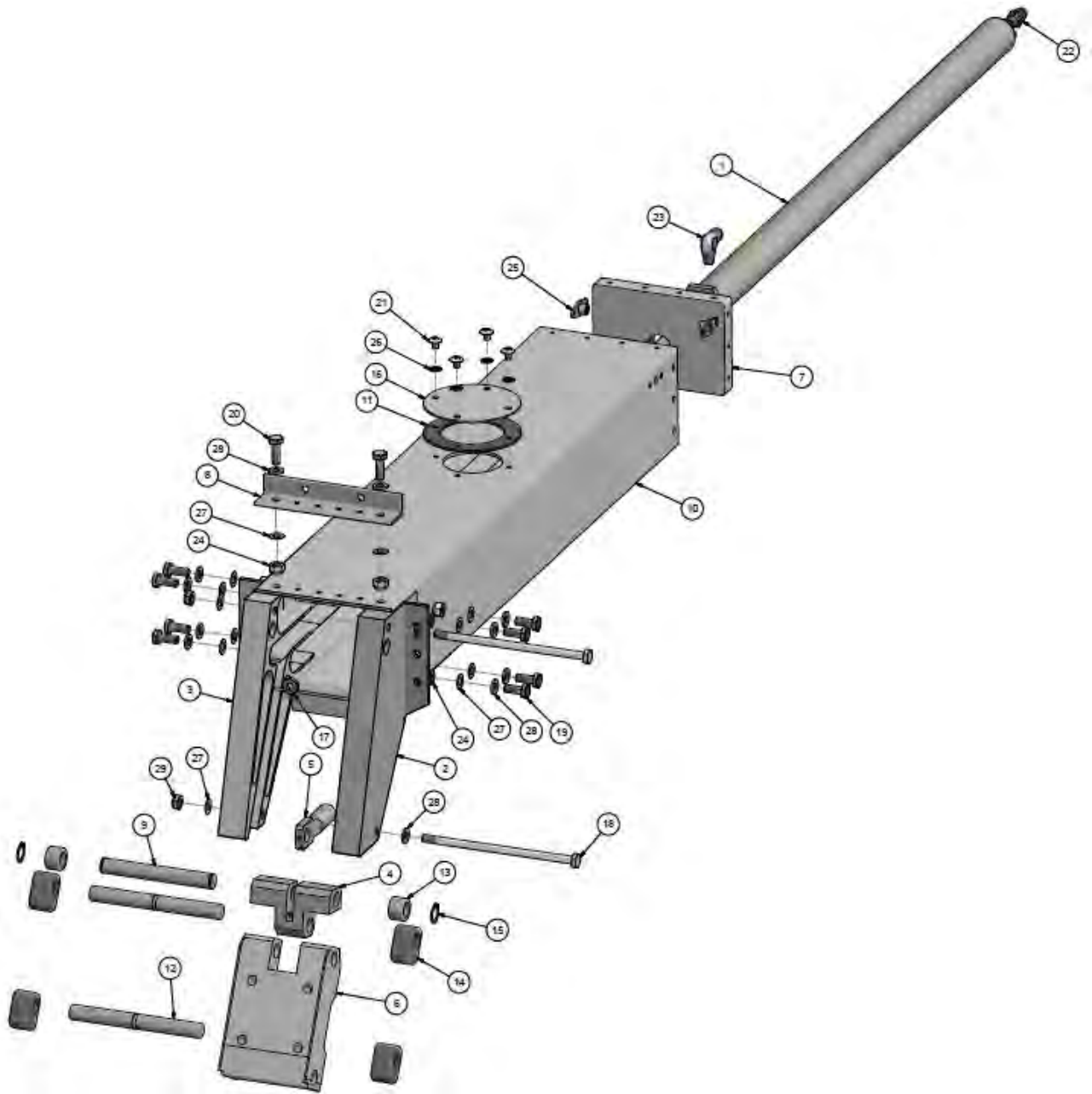

ASSEMBLY – NOSE GEAR RETRACTION  
FIGURE 10

WIPLINE MODEL 3450 FLOAT PARTS MANUAL

ASSEMBLY – NOSE GEAR RETRACTION, FIGURE 10

<u>REF NO.</u>	<u>NO.</u>	<u>REQ.</u>	<u>PART DESCRIPTION</u>	<u>PART NO.</u>
1	1		CYLINDER, NOSE GEAR, 3000/3450	1002572
2	1		END, NOSE GEAR TRACK LEFT	1005837
3	1		END, NOSE GEAR TRACK, RIGHT	1005838
4	1		LINK - TROLLEY, NOSE GEAR	21A07032-005
5	1		END - ROD, CYLINDER, NOSE GEAR	21A07094-002
6	1		TROLLEY - NOSE GEAR	21A07187-009
7	1		END CAP, NOSE BOX	21A07237-002
8	1		EXTRUSION, ANGLE	21A07359-194
9	1		AXLE, TROLLEY LINK	21A07509-007
10	1		NOSE BOX, 3000 FLOAT	1005857
11	1		GASKET, COVER, NOSE BOX, 2100 AND 3000	30A07567-011
12	2		AXLE, TROLLEY	34A07509-008
13	2		BEARING - TROLLEY, NOSE GEAR	3A07530-001
14	4		BLOCK, SLIDE, TROLLEY, NOSE GEAR	3A07604-001
15	2		SNAP RING	5100-46-H
16	1		COVER, BULKHEAD HYD CYL. HOLE	8A01008-080
17	1		NUT	AN316-5R
18	2		BOLT	AN4-53A
19	8		BOLT	AN4-5A
20	2		BOLT	AN4-6A

WIPLINE MODEL 3450 FLOAT PARTS MANUAL

ASSEMBLY – NOSE GEAR RETRACTION, FIGURE 10

<u>REF NO.</u>	<u>NO.</u>	<u>PART DESCRIPTION</u>	<u>PART NO.</u>
<u>NO.</u>	<u>REQ.</u>		
21	4	SCREW, MACHINE, TRUSS HEAD	AN526-1032R4
22	1	NIPPLE, FLARED TUBE AND PIPE THREAD	AN816-4D
23	1	ELBOW	MS20822-4D
24	10	NUT	MS21044N4
25	2	NUT PLATE	MS21078-4
26	4	STAR WASHER	MS35333-39
27	12	WASHER	NAS1149D0416J
28	12	WASHER	NAS1149D0463J
29	2	KAYNAR NUT	NAS679-A4W
	1	NOSE SPRING (NOT SHOWN)	34A06656-001

THIS PAGE INTENTIONALLY LEFT BLANK

WIPLINE MODEL 3450 FLOAT PARTS MANUAL

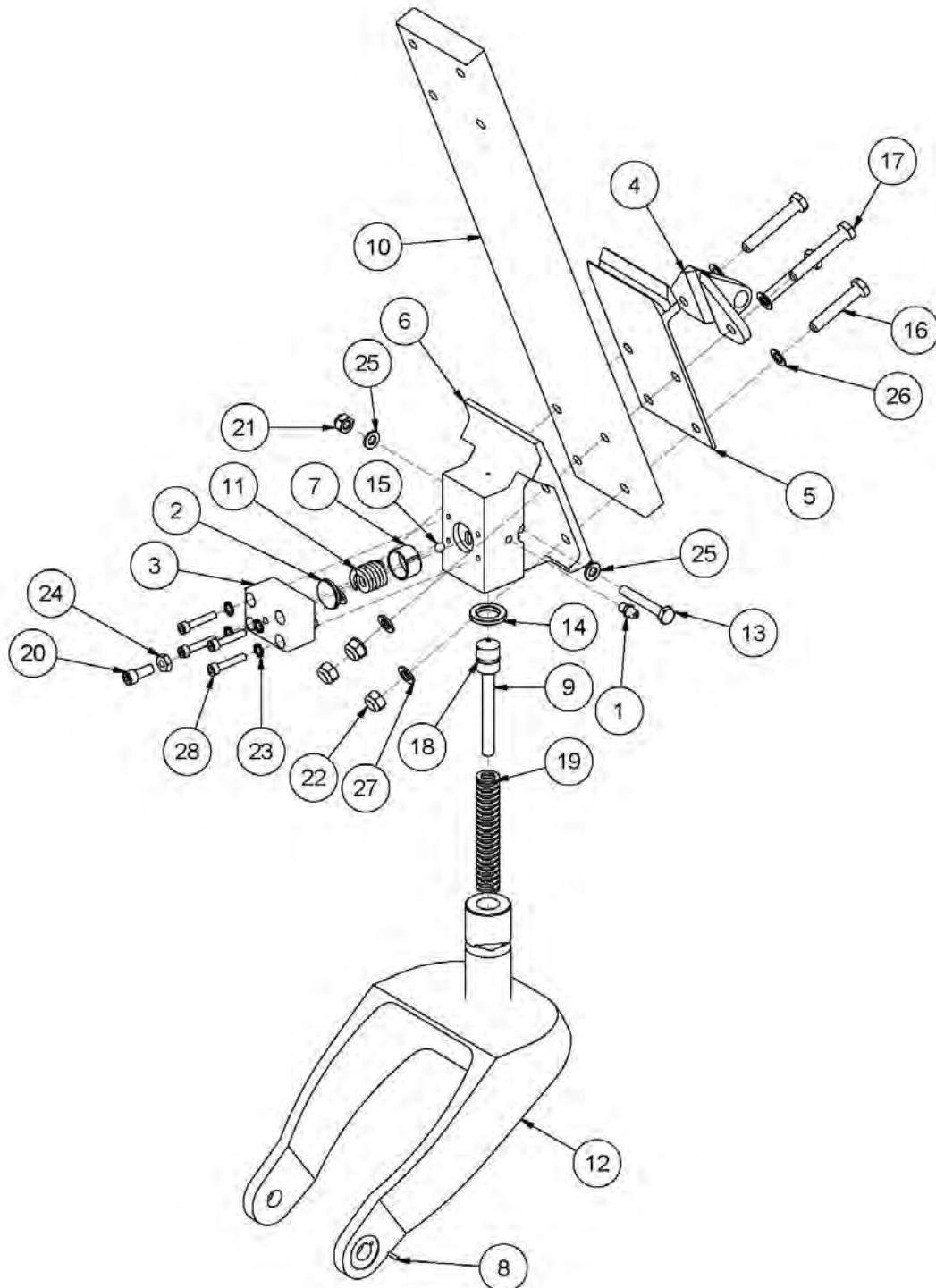

ASSEMBLY – NOSE GEAR – LOWER  
FIGURE 11

## WIPLINE MODEL 3450 FLOAT PARTS MANUAL

## ASSEMBLY – NOSE GEAR - LOWER, FIGURE 11

<u>REF NO.</u>	<u>NO.</u>	<u>PART DESCRIPTION</u>	<u>PART NO.</u>
1	1	COMMON GREASEZERK	1095K41
2	1	PRESSURE PLATE	21A06160-053
3	1	BLOCK - SPRING	21A06194-005
4	1	TOW HOOK NOSE GEAR	21A06213-006
5	1	BEARING PLATE, LOWER, NOSE GEAR	21A06237-001
6	1	BLOCK - PIVOT, NOSE GEAR	21A06318-005
7	1	FRICTION CUP	21A06475-006
8	1	PIN, ANTIROTATION	21A06476-003
9	1	PLUNGER- NOSE WHEEL, 21,23,3,34	21A06605-002
10	1	SPRING NOSE GEAR	21A06653-001
11	1	PRESSURE SPRING	21A06705-005
12	1	ASSEMBLY,- PIVOT AND FORK, NOSE GEAR	30A06000-024
13	1	BOLT - MODIFIED, PIVOT BLOCK	30A06702-016
14	1	THRUST WASHER	3A06602-001
15	1	1/4" CHROME BALL BEARING	9528K15
16	2	BOLT	AN5-15A
17	2	BOLT	AN5-17A
18	1	O-RING	AN6227-9
19	1	SPRING	M62-350
20	1	BOLT	MS16997-60
21	1	NUT	MS21044N4
22	4	NUT	MS21044N5
23	4	STAR WASHER	MS35333-39
24	1	NUT	MS35649-2252
25	2	WASHER	NAS1149D0463J
26	4	WASHER	NAS1149F0532P
27	4	WASHER	NAS1149F0563P
28	4	BOLT	NAS1352-316P

WIPLINE MODEL 3450 FLOAT PARTS MANUAL

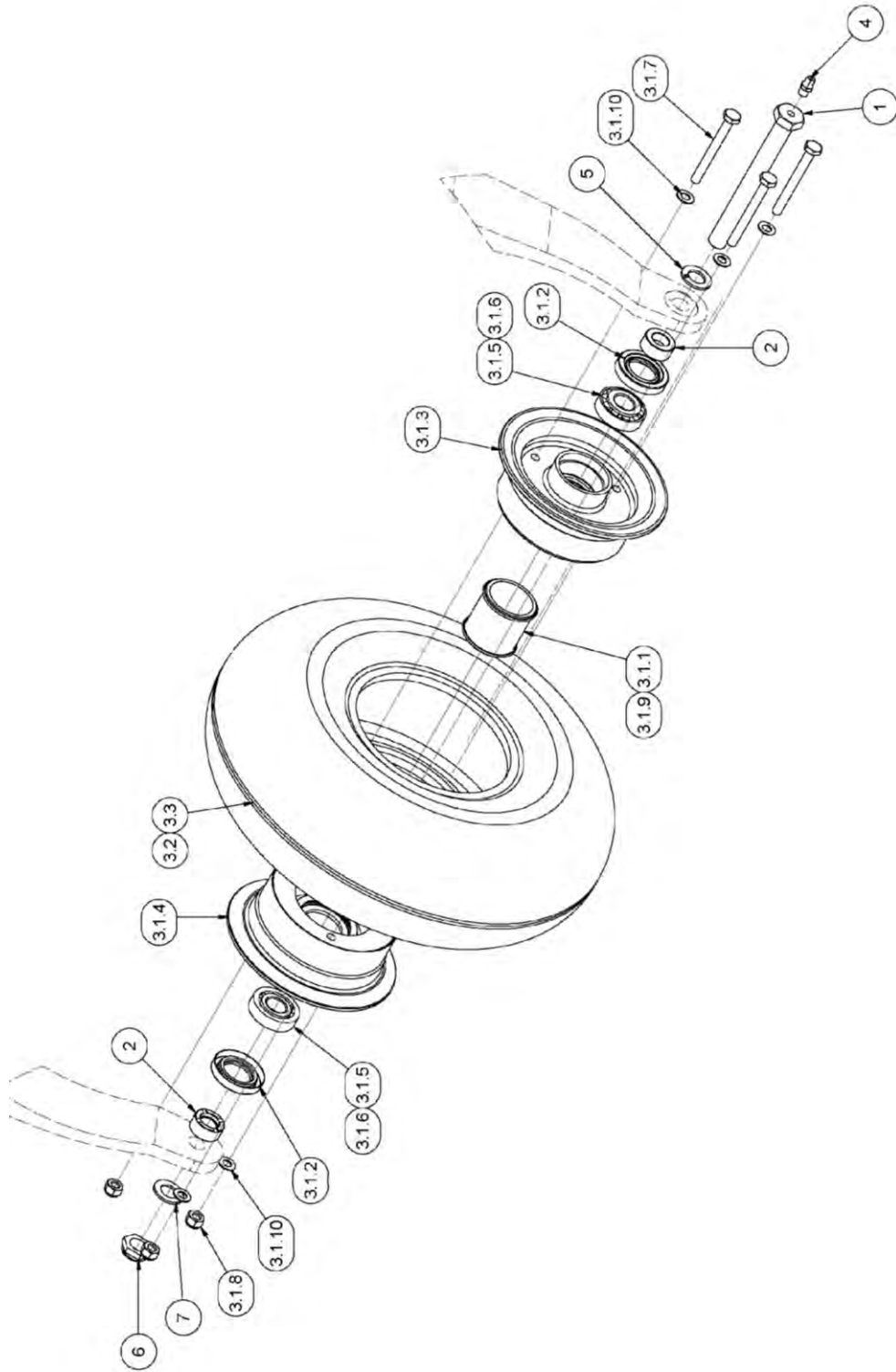

ASSEMBLY - NOSE WHEEL (GROVE)  
FIGURE 12A

WIPLINE MODEL 3450 FLOAT PARTS MANUAL  
 ASSEMBLY – NOSE GEAR - LOWER, FIGURE 12A

<u>REF NO.</u>	<u>NO.</u>	<u>REQ.</u>	<u>PART DESCRIPTION</u>	<u>PART NO.</u>
1	1		BOLT, MODIFIED, AXLE, NOSE GEAR	1005927
2	2		SPACER	1005928
3	1		ASSEMBLY, NOSE WHEEL	1006679
3.1	1		WHEEL ASSEMBLY, GROVE	49-12AF-001
3.1.1	1		GREASE RETAINER	010-019
3.1.2	2		SEAL	010-026
3.1.3	1		WHEEL HALF INNER	015-020A
3.1.4	1		WHEEL HALF OUTER	016-020AF
3.1.5	2		BEARING CORE	A4050
3.1.6	2		BEARING CONE	A4138
3.1.7	3		BOLT	AN4-23A
3.1.8	3		NUT	MS21044N-4
3.1.9	2		O-RING	MS28775-029
3.1.10	6		WASHER	NAS1149F0416
3.2	1		TUBE	XA1AB
3.3	1		TIRE	AD1B2
4	1		COMMON GREASEZERK	1095K41
5	1		MODIFIED WASHER	3A06702-003
6	1		NUT	MS21083N8
7	1		WASHER	NAS1149D0863J



WIPLINE MODEL 3450 FLOAT PARTS MANUAL

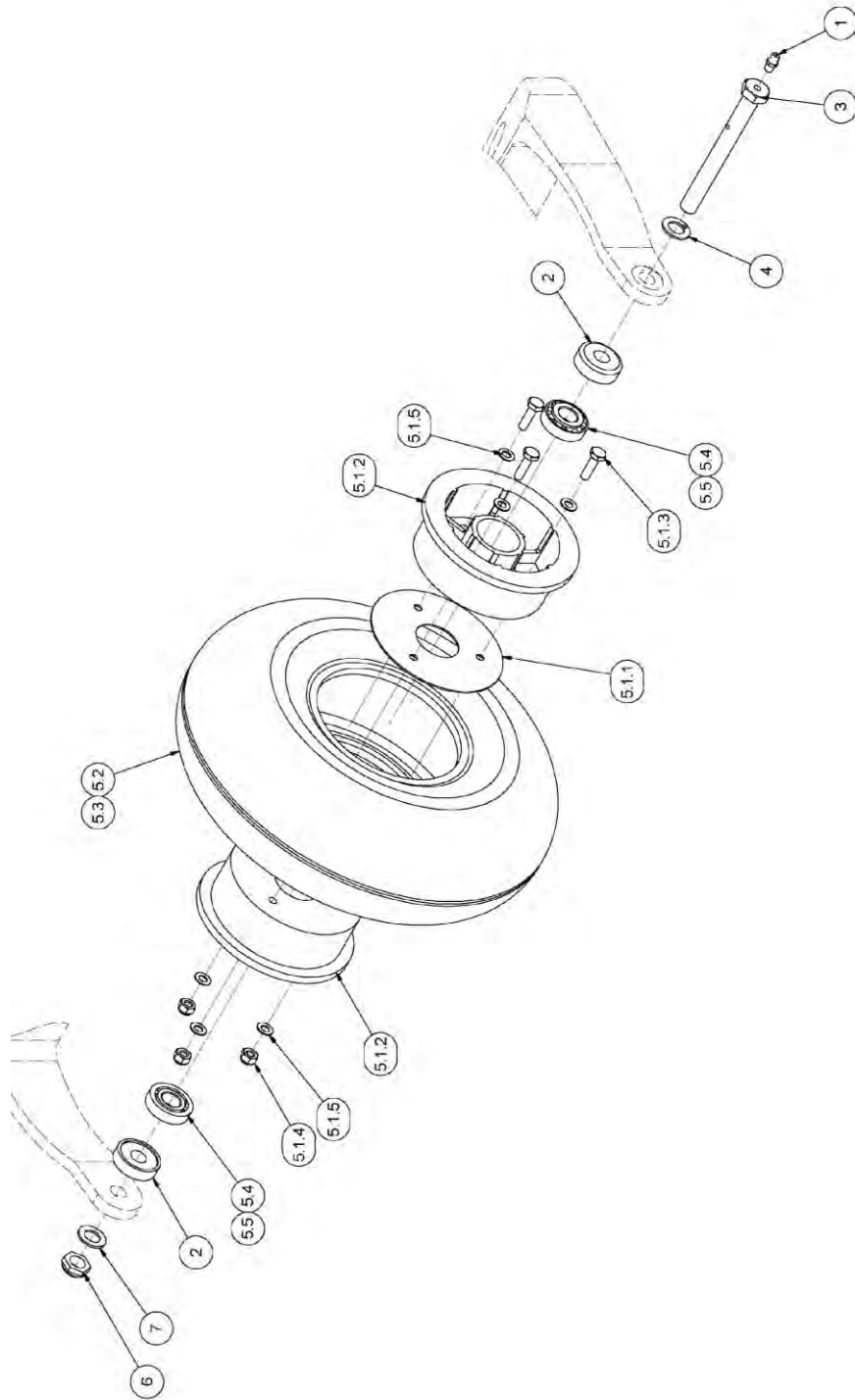

ASSEMBLY - NOSE WHEEL (PARKER)  
FIGURE 12B

WIPLINE MODEL 3450 FLOAT PARTS MANUAL  
 ASSEMBLY – NOSE GEAR - LOWER, FIGURE 12B

<u>REF NO.</u>	<u>NO.</u>	<u>PART DESCRIPTION</u>	<u>PART NO.</u>
1	1	COMMON GREASEZERK	1095K41
2	2	SPACER - NOSE WHEEL - SMALL FLOAT	3A06259-001
3	1	BOLT, MODIFIED, AXLE, NOSE GEAR	3A06702-002
4	1	MODIFIED WASHER	3A06702-003
5	1	NOSE WHEEL ASSEMBLY	30A06000-025
5.1	1	PARKER WHEEL ASSEMBLY	D-30380
5.1.1	1	GASKET	068-30373
5.1.2	2	WHEEL HALF	161-30382
5.1.3	3	BOLT	AN4-7A
5.1.4	3	NUT	MS21044N4
5.1.5	6	WASHER	NAS1149F0432P
5.2	1	TIRE	AD1B2
5.3	1	TUBE	XA1AB
5.4	2	BEARING CORE	A4050
5.5	2	BEARING CONE	A4138
6	1	NUT	MS21083N8
7	1	WASHER	NAS1149D0863J

WIPLINE MODEL 3450 FLOAT PARTS MANUAL

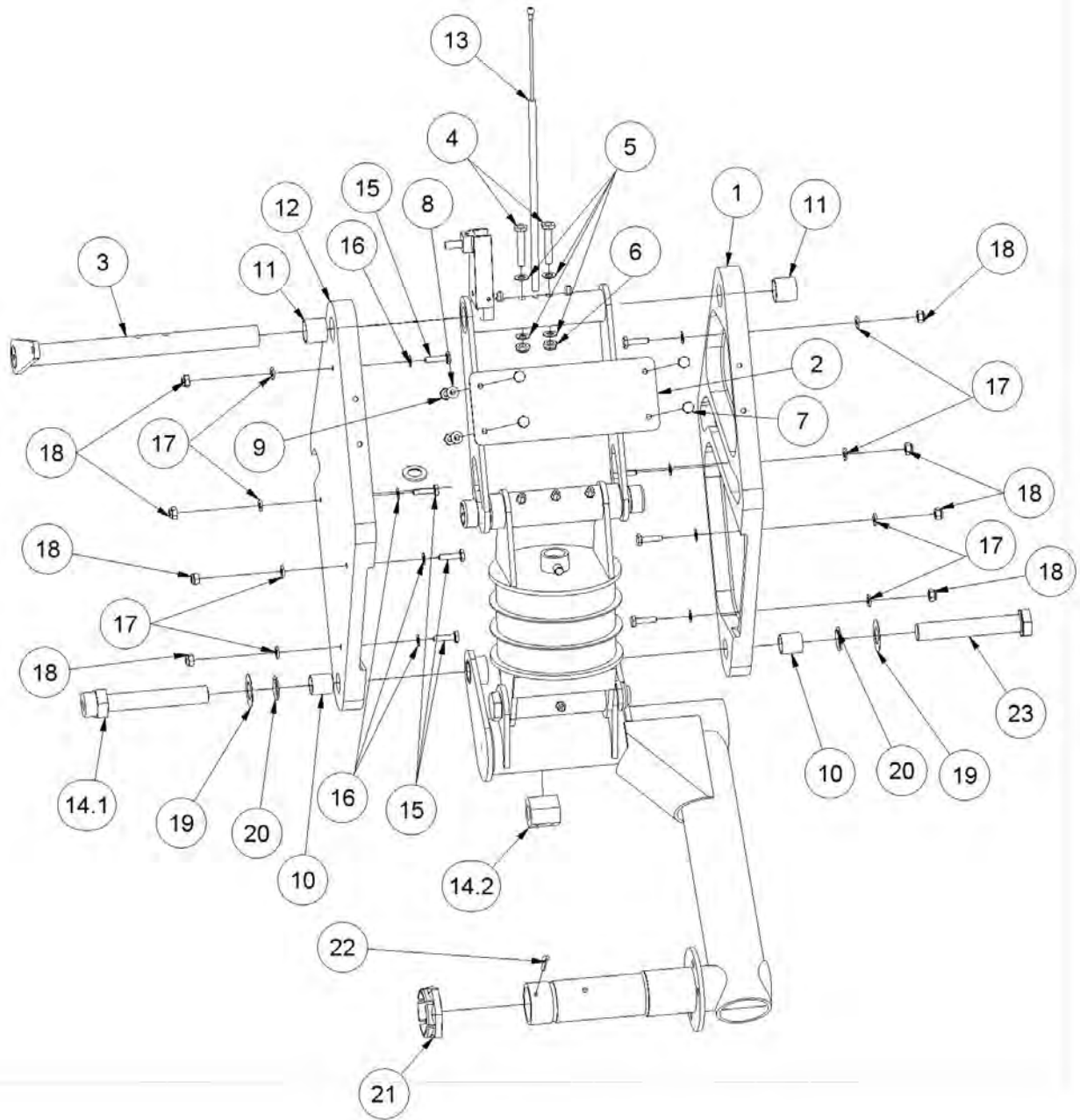

MAIN GEAR INSTALLATION  
FIGURE 13

## WIPLINE MODEL 3450 FLOAT PARTS MANUAL

## MAIN GEAR INSTALLATION, FIGURE 13

<u>REF NO.</u>	<u>NO.</u>	<u>PART DESCRIPTION</u>	<u>PART NO.</u>
1	1	TRACK - MAIN GEAR - RIGHT	30A05114-008
2	1	SPACING PLATE	30A05003-085
3	1	ASS'Y. ARM RETRACT	30A05000-039
4	2	BOLT	NAS6204-17
5	4	WASHER	NAS1149F0432P
6	2	NUT	MS21083N4
7	4	BOLT	AN3-5A
8	4	WASHER	NAS1149D0316J
9	4	NUT	MS21044N3
10	2	BUSHING	10DU12
11	2	BUSHING	12DU12
12	1	TRACK - MAIN GEAR - LEFT	30A05114-007
13	1	ASS"Y - ARM - GEAR INDICATOR	30A05000-027
14	1	MAIN GEAR BOLT ASS"Y - LOWER	30A05000-038
14.1	1	MODIFIED BOLT - DRAG LINK ATTACH	30A05558-001
14.2	1	COUPLING - MAIN GEAR	30A04574-001
15	8	BOLT	AN3-6A
16	8	WASHER	NAS1149D0316J
17	8	WASHER	NAS1149D0363J
18	8	NUT	MS21044N3
19	2	WASHER	NAS1149D1016J
20	2	SEALING WASHER	93783A033
21	1	NUT, AXLE	MS21025-24
22	1	COTTER PIN	MS24665-351
23	1	BOLT	NAS6210-52

WIPLINE MODEL 3450 FLOAT PARTS MANUAL

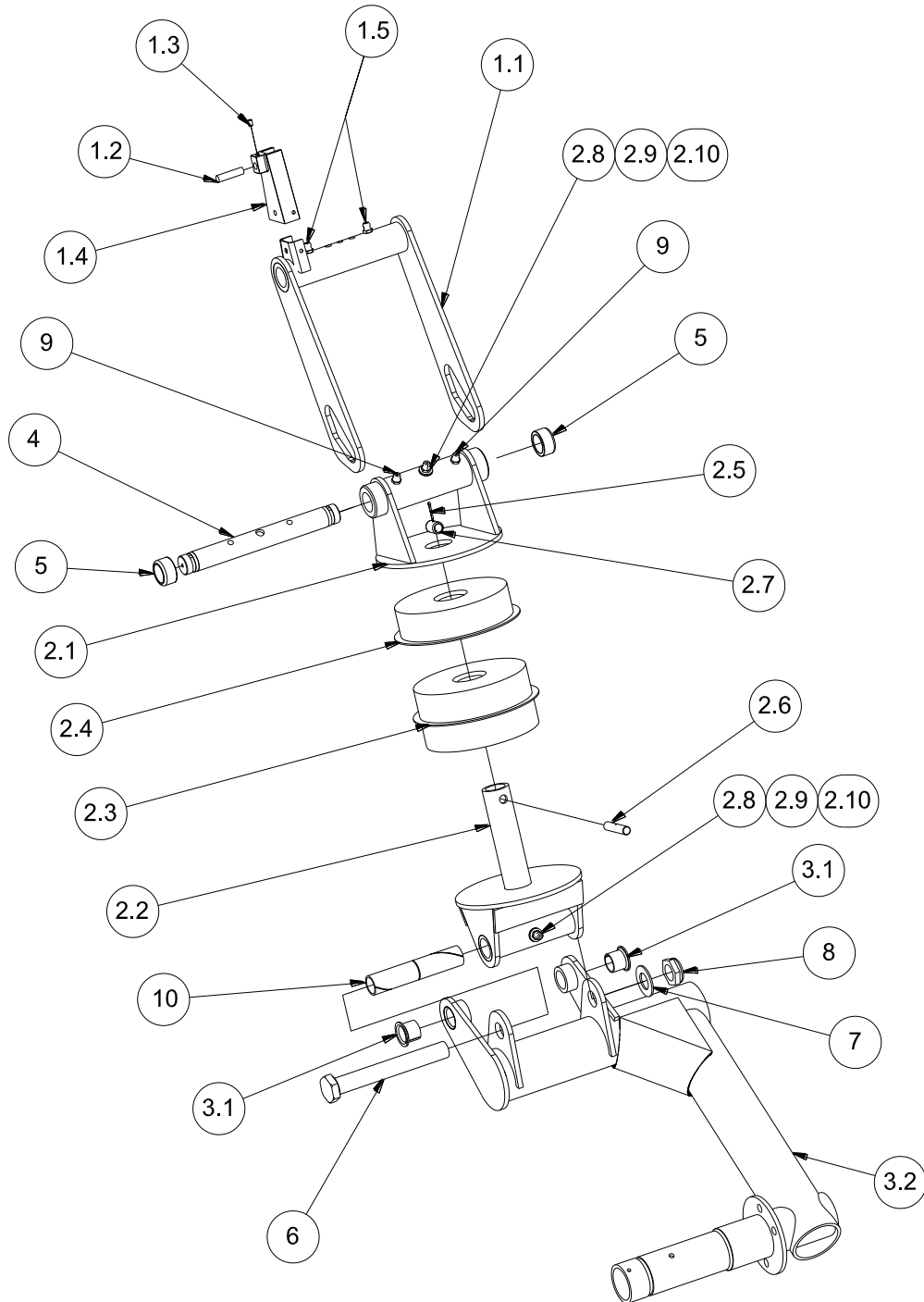

MAIN GEAR RETRACTION  
FIGURE 14

WIPLINE MODEL 3450 FLOAT PARTS MANUAL

MAIN GEAR RETRACTION, FIGURE 14

<u>REF NO.</u>	<u>NO.</u>	<u>REQ.</u>	<u>PART DESCRIPTION</u>	<u>PART NO.</u>
1	1		ASS'Y. ARM RETRACT - DRAG LINK	30A05000-042
1.1	1		ASS'Y. ARM RETRACT - DRAG LINK	30A05000-041
1.2	1		CYLINDRICAL MAGNET	3A05701-001
1.3	1		SET SCREW	1032 NFX 3/16
1.4	1		PROX. SWITCH HOLDER	30A05214-007
1.5	2		COMMON GREASEZERK	1095K41
	2		WASHER	NAS1149F0463P
2	1		ASS"Y - SHOCK STRUT	30A04000-100
2.1	1		ASSEMBLY - END SHOCK STRUT - UPPER	30A04000-093
2.2	1		ASSEMBLY - END SHOCK STRUT - LOWER	30A04000-120
2.3	1		DUAL BUSHING ASSEMBLY	1002090
2.4	1		BUSHING ASSEMBLY	1001103
2.5	1		COTTER PIN	MS24665-151
2.6	1		PIN - RETAINING, SHOCK STRUT	30A04476-004
2.7	1		SLEEVE - SHOCK STRUT RETAINER	30A04459-002
2.8	2		COMMON GREASEZERK	1095K41
2.9	2		WASHER	NAS1149D0416J
2.10	2		WASHER	NAS1149D0463J
3	1		DRAG LINK - MAIN GEAR	30A04000-091
3.1	2		BUSHING	10FDU10
3.2	1		ASS'Y. DRAG LINK, MAIN GEAR	30A04000-091

WIPLINE MODEL 3450 FLOAT PARTS MANUAL

MAIN GEAR RETRACTION, FIGURE 14

<u>REF NO.</u>	<u>NO.</u>	<u>REQ.</u>	<u>PART DESCRIPTION</u>	<u>PART NO.</u>
4	1		SHAFT - AXLE - SHOCK STRUT	30A04454-007
5	2		ROLLER, SHOCK STRUT - RETRACT	21A05520-003
6	1		BOLT - DRAG LINK	30A05702-016
7	1		WASHER	NAS1149F1063P
8	1		NUT	MS21083N10
9	2		COMMON GREASEZERK	1095K41
10	1		BUSHING	30A04475-006

THIS PAGE INTENTIONALLY LEFT BLANK



WIPLINE MODEL 3450 FLOAT PARTS MANUAL

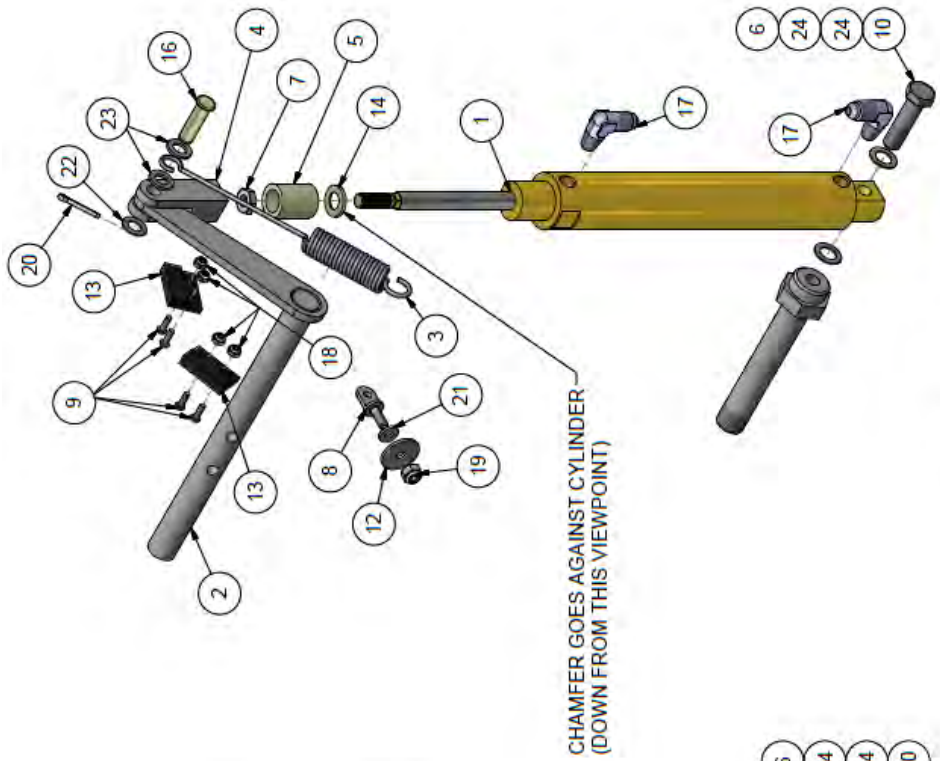

**NEW STYLE CLEVIS**  
(SEE SERVICE LETTER 139)

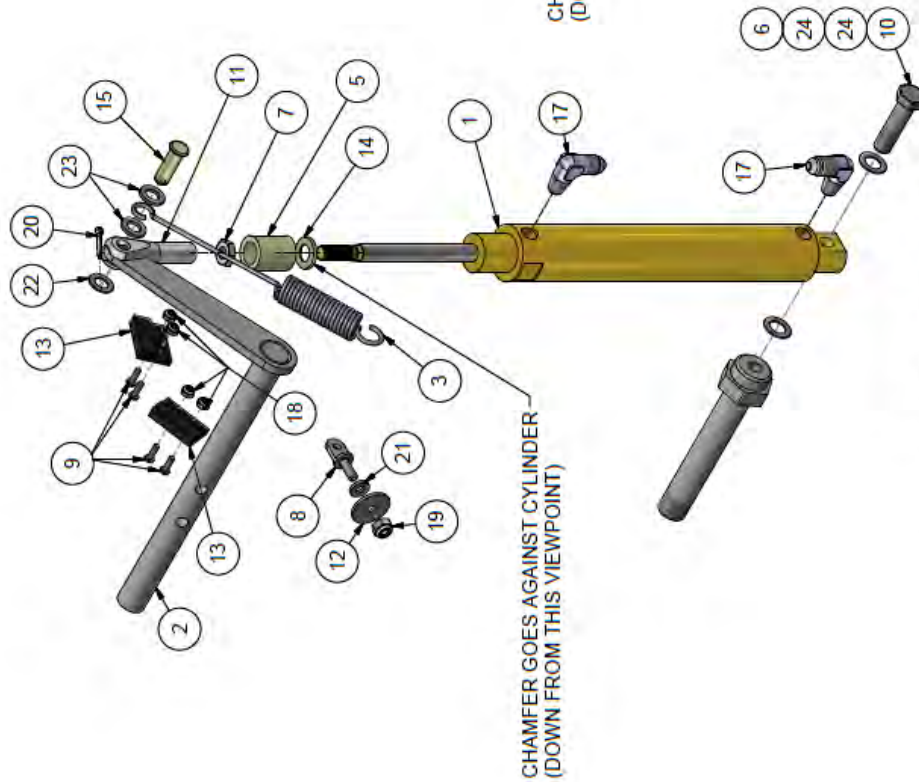

**OLD STYLE CLEVIS**

MAIN GEAR HYDRAULIC INSTALLATION  
FIGURE 15

WIPLINE MODEL 3450 FLOAT PARTS MANUAL

MAIN GEAR HYDRAULIC INSTALLATION, FIGURE 15

<u>REF NO.</u>	<u>NO.</u>	<u>PART DESCRIPTION</u>	<u>PART NO.</u>
1	1	CYLINDER-MAIN GEAR, 3000-3450	1002573
2	1	WELDMENT, ARM RETRACT, RIGHT	21A05000-016
3	1	SPRING - GEAR	21A05525-008
4	1	SPACER - HYDRAULIC CYLINDER	30A05252-001
5	1	CLEVIS - RETRACT ARM, MAIN GEAR, (30/3450)	30A05460-001
6	1	MODIFIED BOLT, DRAG LINK ATTACH	30A05558-001
7	1	NUT	AN316-5R
8	1	EYE BOLT	AN42-4A
9	4	SCREW, MACHINE	AN515-4R6
10	1	BOLT	AN6-13A
11	1	TERMINAL, FLY WIRE	AN665-46RS
12	1	WASHER	AN970-3
13	2	HAMLIN MAGNETIC SWITCH	Hamlin 59135-20
14	1	WASHER - COUNTER SUNK	MS20002C6
15	1	CLEVIS PIN	MS20392-4C25
16	1	CLEVIS PIN	MS20392-4C29
17	2	ELBOW	MS20822-4-4D
18	4	NUT	MS21044N04
19	1	NUT	MS21044N3
20	2	COTTER PIN	MS24665-283
21	1	WASHER	NAS1149D0363J
22	1	WASHER	NAS1149F0532P
23	2	WASHER	NAS1149F0563P
24	2	WASHER	NAS1149F0632P

WIPLINE MODEL 3450 FLOAT PARTS MANUAL

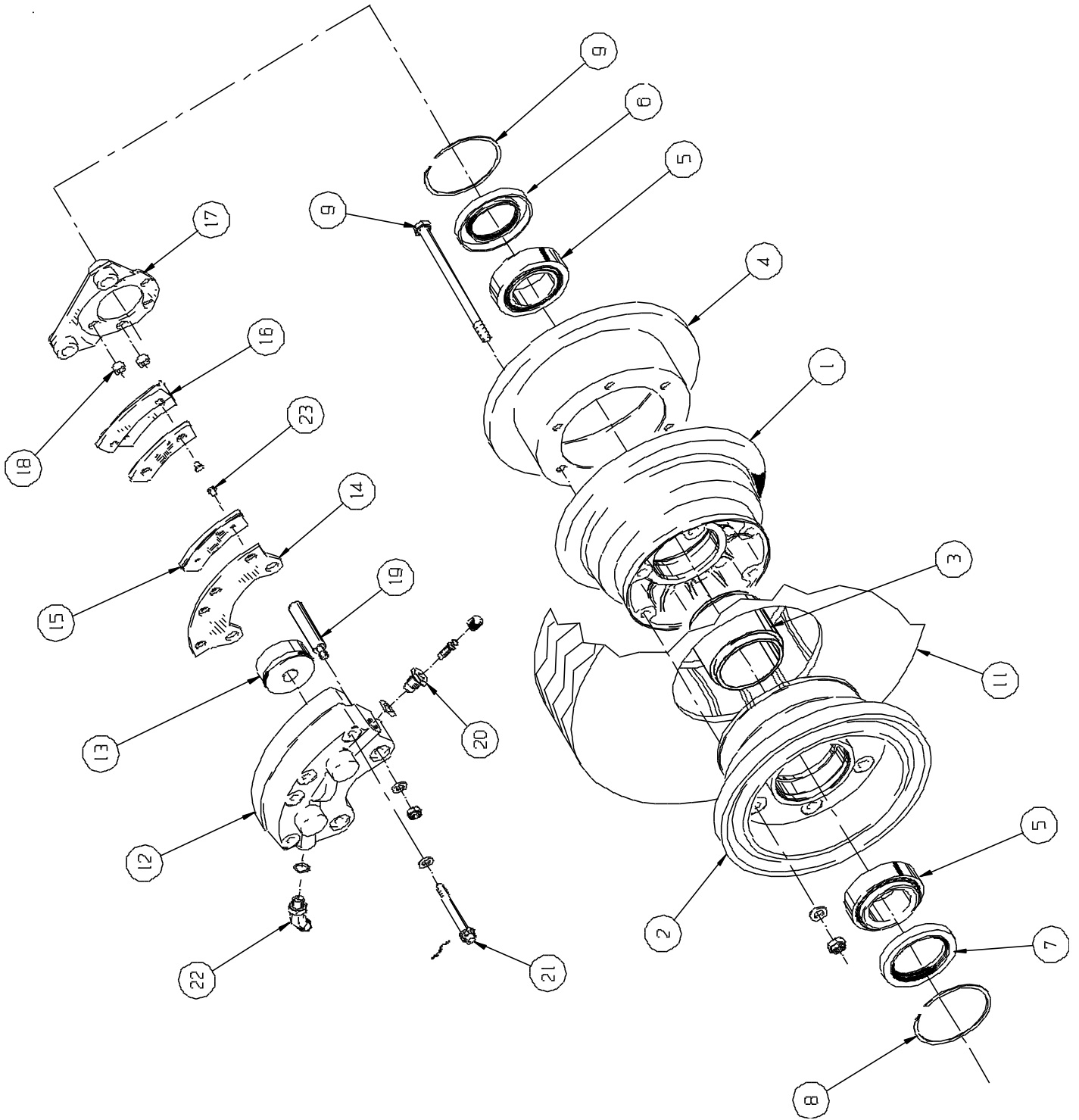

ASSEMBLY – MAIN GEAR WHEEL  
FIGURE 16

WIPLINE MODEL 3450 FLOAT PARTS MANUAL

ASSEMBLY – MAIN GEAR WHEEL, FIGURE 16

<u>REF NO.</u>	<u>NO.</u>	<u>REQ.</u>	<u>PART DESCRIPTION</u>	<u>PART NO.</u>
1	1		WHEEL ASS'Y (W/ TIRE & TUBE)	8A04000-031
2	1		WHEEL ASS'Y (BOTH HALVES)	40-418-3
3	1		SPACER – GREASE DAM	067-14700
4	1		DISC – BRAKE	164-24500
5	2		CUP – BEARING	13836
	2		CONE – BEARING	13889
6	1		SEAL – GREASE	473232
7	1		SEAL – GREASE	472439
8	2		RING - SNAP	155-14300
9	6		BOLT	AN5-35A
	6		WASHER	NAS1149F0563P
	6		NUT	MS21042-5
10	1		NAMEPLATE – “WARNING” (NOT SHOWN)	166-20000
	1		NAMEPLATE (NOT SHOWN)	166-19700
11	1		TIRE 6.00 X 6, 8 PLY	AA1E6*
	1		TUBE 6.00 X 6	XA1AD**
12	1		BRAKE ASS'Y	30A04000-103 RH 30A04000-102 LH
	1		BRAKE	6A04561-001
13	2		PISTON	062-10700
	1		O-RING	MS28775-222
14	1		PLATE - PRESSURE	063-01100

## WIPLINE MODEL 3450 FLOAT PARTS MANUAL

## ASSEMBLY – MAIN GEAR WHEEL, FIGURE 16

<u>REF NO.</u>	<u>NO.</u>	<u>REQ.</u>	<u>PART DESCRIPTION</u>	<u>PART NO.</u>
15	2		LINING - BRAKE	066-10500
16	1		PLATE – BACK	064-01500
17	1		PLATE - TORQUE	075-20700
18	1		BUSHING	145-01000
19	2		BOLT - ANCHOR	069-03100
	2		WASHER	NAS1149F0463P
	2		NUT	MS21044N4
20	1		SEAT - BLEEDER	081-00200
	1		O-RING	MS28775-012
	1		SCREW – BLEEDER	079-00300
	1		CAP – BLEEDER	183-00100
21	4		BOLT	MS21250H04026
	4		WASHER	MS20002C4
	A/R		LOCKWIRE	MS20995-C32
22	1		FITTING	104-04700
	1		O-RING	MS28775-012
23	4		RIVET	105-00200

THIS PAGE INTENTIONALLY LEFT BLANK

WIPLINE MODEL 3450 FLOAT PARTS MANUAL

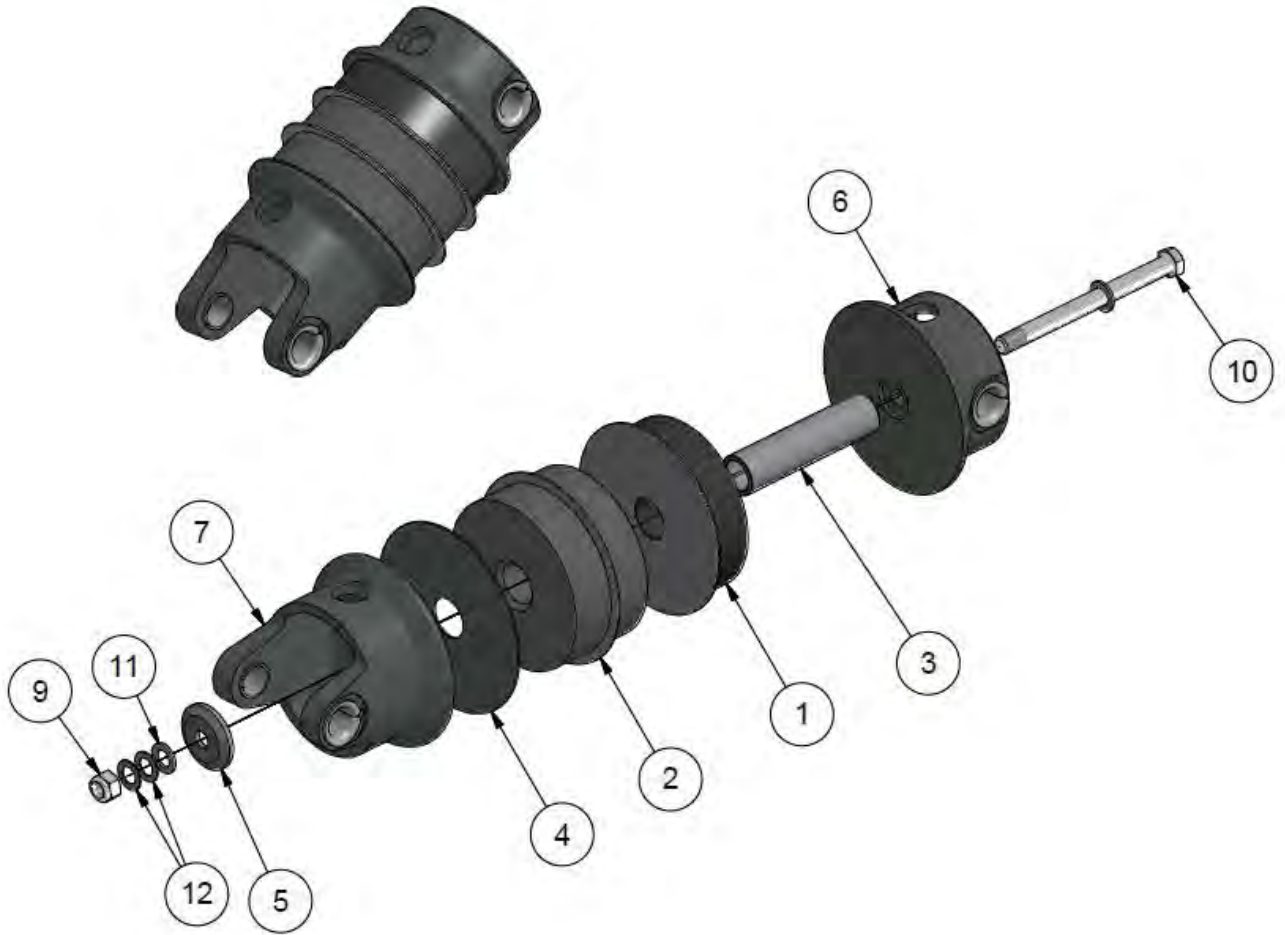

ASSEMBLY, SHOCK, MAIN GEAR (ALUM. GEAR)  
FIGURE 17

WIPLINE MODEL 3450 FLOAT PARTS MANUAL

ASSEMBLY – MAIN GEAR WHEEL, FIGURE 17

<u>REF NO.</u>	<u>NO.</u>	<u>PART DESCRIPTION</u>	<u>PART NO.</u>
	<b>2</b>	<b>ASS'Y. SHOCK, HEAVY DUTY, MAIN GEAR (185)</b>	<b>1004286-04</b>
1	1	BUSHING ASS'Y., SHOCK STRUT	1001103
2	1	BUSHING ASS'Y., DUAL, SHOCK STRUT	1002090
3	1	TUBE, STRUT, MAIN	1004267
4	1	SHOCK SPACER, MAIN	1004268
5	1	STRUT END CAP, MAIN	1004269
6	1	ASS'Y., UPPER SHOCK STRUT, MAIN	1005765
7	1	ASS'Y., LOWER SHOCK STRUT, MAIN	1005766
9	1	NUT	MS21044N7
10	1	BOLT	AN7-51A
11	2	WASHER	NAS1149D0763P
12	2	WASHER	NAS1149D0732P



WIPLINE MODEL 3450 FLOAT PARTS MANUAL

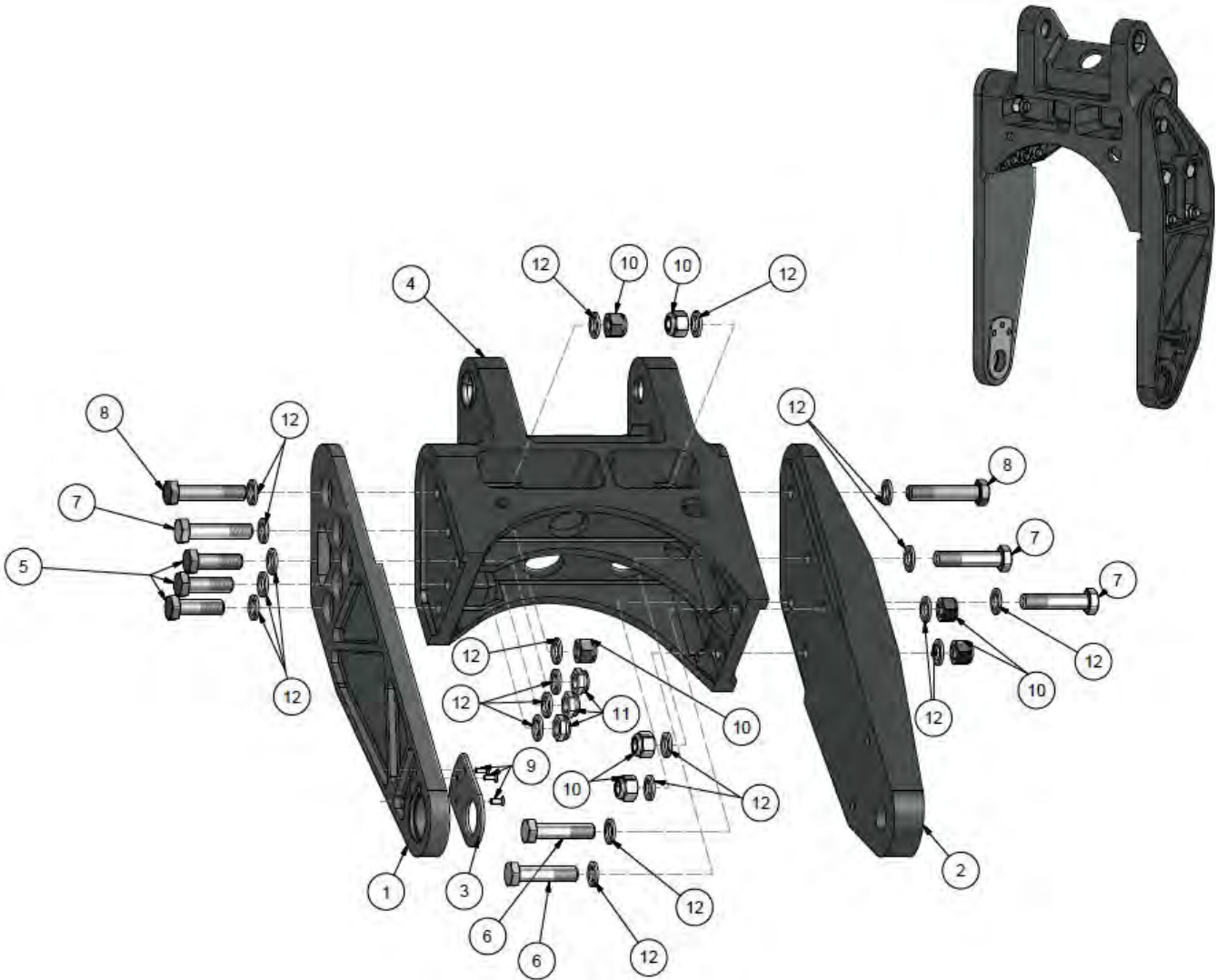

ASSY. PIVOT, MAIN GEAR W/O WHEEL (ALUM. GEAR)  
FIGURE 18

WIPLINE MODEL 3000 FLOAT PARTS MANUAL

ASSY., PIVOT, MAIN GEAR W/O WHEEL (ALUM. GEAR)  
FIGURE 18

<u>REF</u> <u>NO.</u>	<u>NO.</u> <u>REQ.</u>	<u>PART DESCRIPTION</u>	<u>PART NO.</u>
	1	<b>ASS'Y., PIVOT, RH, MAIN GEAR W/O WHEEL</b>	<b>1005746</b>
	1	<b>ASS'Y., PIVOT, LH, MAIN GEAR W/O WHEEL</b>	<b>1005747</b>
1	1	LINK ARM, OUTBRD, RT FLOAT	1004274
	1	LINK ARM, OUTBRD, LT FLOAT	1005370
2	1	LINK ARM, INBRD, RT FLOAT	1004275
	1	LINK ARM, INBRD, LT FLOAT	1005369
3	1	GREASE COVER, MAIN GEAR, 3000 3450	1005387
4	1	ASSY, CENTER LINK, RH, MAIN GEAR	1005744
	1	ASSY, CENTER LINK, LH, MAIN GEAR	1005745
5	3	BOLT	AN6-11A
6	2	BOLT	AN6-14A
7	3	BOLT	AN6-15A
8	2	BOLT	AN6-16A
9	3	RIVET-FLAT HEAD	MS20426-4
10	7	NUT	MS21044N6
11	3	NUT	MS21083N6
12	20	WASHER	NAS1149D0663J

WIPLINE MODEL 3450 FLOAT PARTS MANUAL

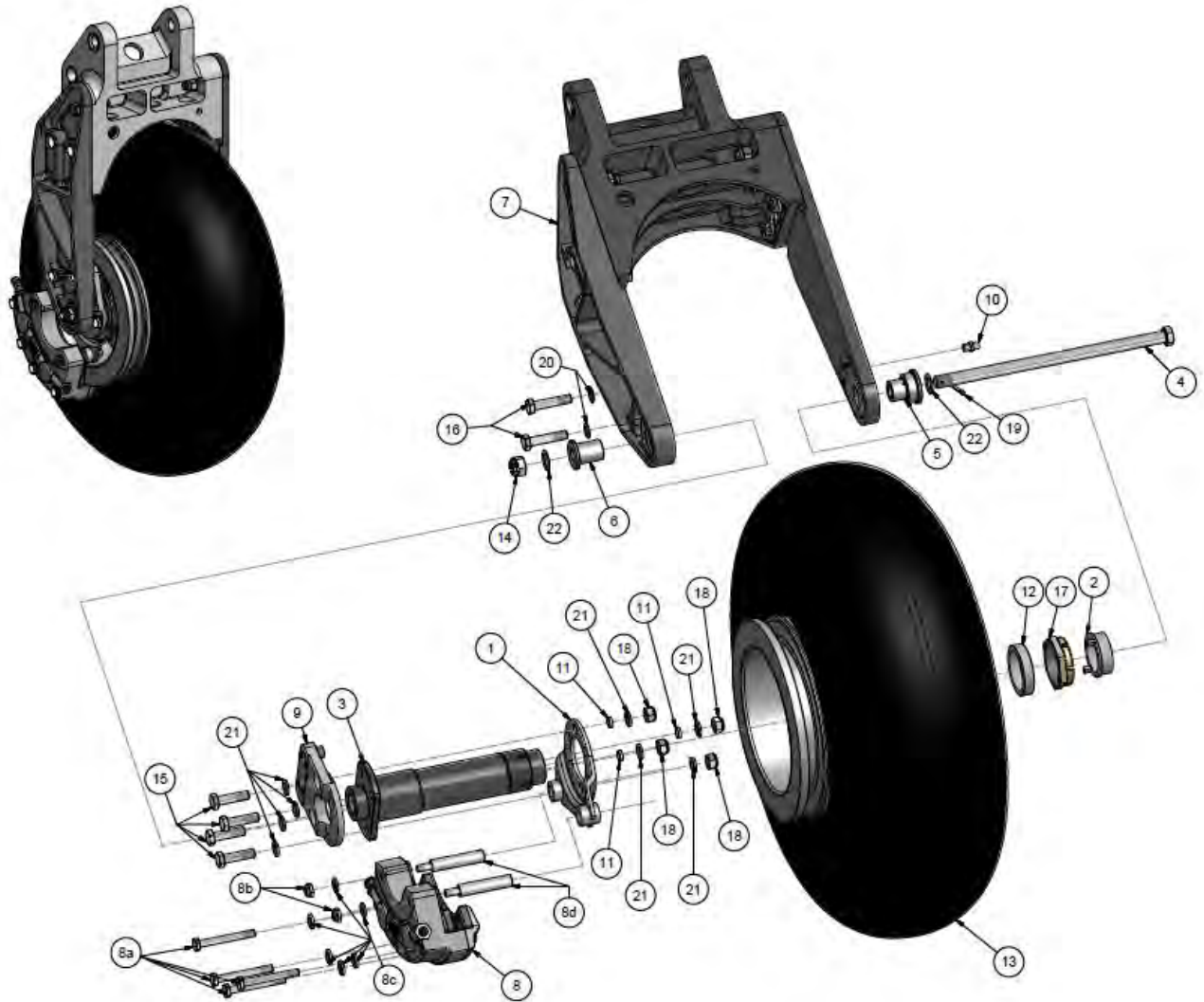

ASSY. PIVOT, MAIN GEAR WITH WHEEL (ALUM. GEAR)  
FIGURE 19

WIPLINE MODEL 3000 FLOAT PARTS MANUAL

ASSY., PIVOT, MAIN GEAR WITH WHEEL (ALUM. GEAR)  
FIGURE 19

<u>REF</u> <u>NO.</u>	<u>NO.</u> <u>REQ.</u>	<u>PART DESCRIPTION</u>	<u>PART NO.</u>
	1	<b>ASS'Y., PIVOT, RH, MAIN GEAR</b>	<b>1004288</b>
	1	<b>ASS'Y., PIVOT, LH, MAIN GEAR</b>	<b>1005377</b>
1	1	TORQUE PLATE	075-20700
2	1	LOCKING HUB, MAIN	1004281
3	1	AXLE, MAIN GEAR	1004283
4	1	BOLT - 7/16-20 UNF-3A, 8.20 GRIP	1005374
5	1	HUB, AXLE	1005378
6	1	HUB, AXLE	1005389
7	1	ASS'Y., PIVOT, RH, MAIN GEAR W/O WHEEL	1005746
	1	ASS'Y., PIVOT, LH, MAIN GEAR W/O WHEEL	1005747
8	1	BRAKE ASSEMBLY COMPLETE, RH	1005844
	1	BRAKE ASSEMBLY COMPLETE, LH	1005775
8a	4	BOLT	AN4H21A
8b	2	NUT	MS21083N4
8c	6	WASHER	NAS1149F0463P
8d	2	BOLT - ANCHOR	069-03100
9	1	ASSY, BRACKET, ANTI ROTATION, MAIN, 3000 3450	1005855
10	1	COMMON GREASEZERK	1095K41
11	3	BUSHING, TORQUE PLATE	30A04523-002
12	1	AXLE SPACER, MAIN WHEEL	6A04093-002
13	1	MAIN WHEEL ASSEMBLY	8A04000-031
14	1	NUT, HEX, CASTLE , 7/16-20 UNF	AN310-7
15	4	BOLT	AN5-11A
16	2	BOLT	AN5-13A
17	1	NUT, AXLE	MS21025-24
18	6	NUT	MS21044N5
19	1	COTTER PIN	MS24665-302

WIPLINE MODEL 3000 FLOAT PARTS MANUAL

ASSY., PIVOT, MAIN GEAR WITH WHEEL (ALUM. GEAR)  
FIGURE 19

<u>REF</u> <u>NO.</u>	<u>NO.</u> <u>REQ.</u>	<u>PART DESCRIPTION</u>	<u>PART NO.</u>
20	2	WASHER	NAS1149F0532P
21	12	WASHER	NAS1149F0563P
22	2	WASHER	NAS1149F0732P

THIS PAGE INTENTIONALLY LEFT BLANK

WIPLINE MODEL 3450 FLOAT PARTS MANUAL

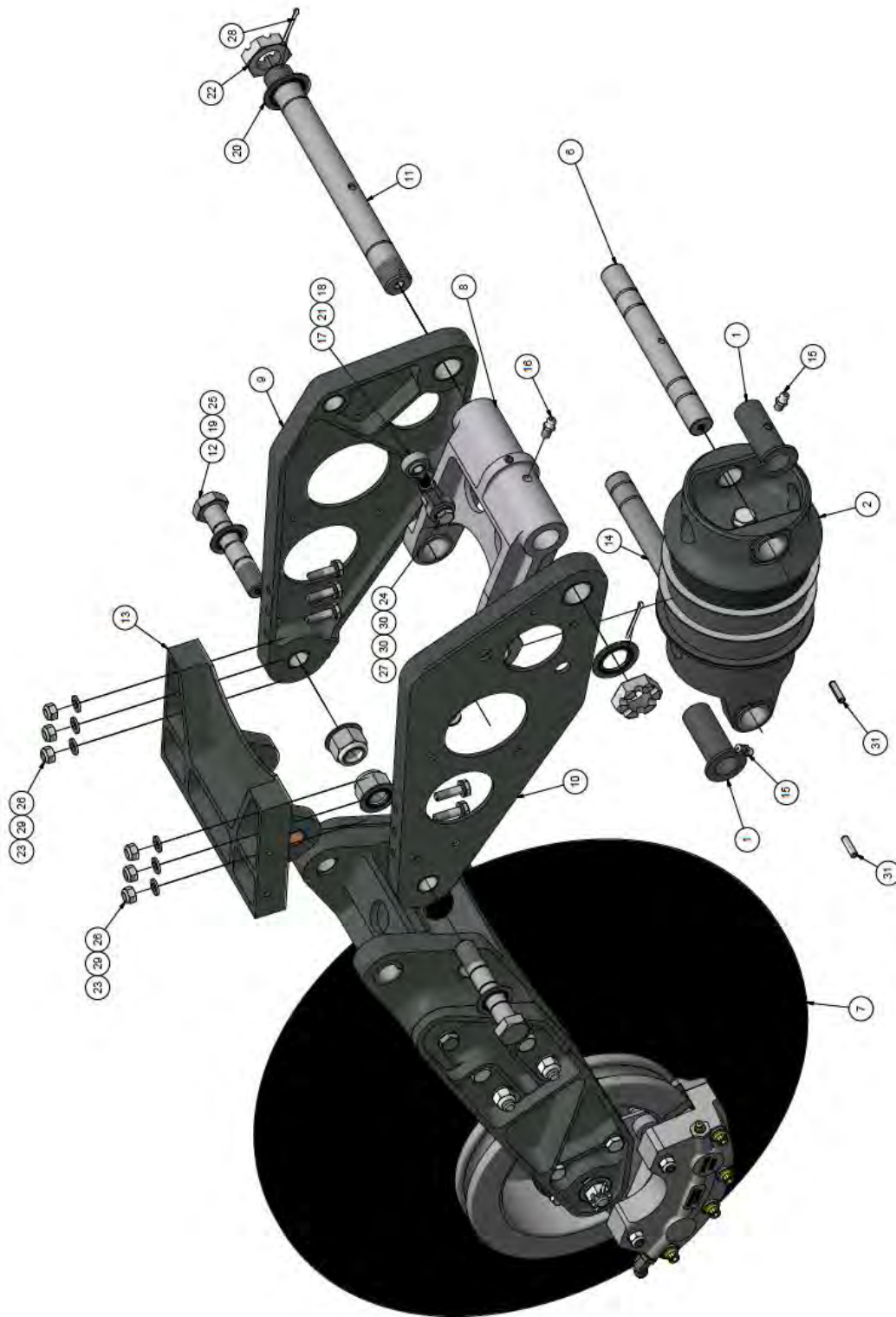

ASSY., MAIN GEAR (ALUM. GEAR)  
FIGURE 20

WIPLINE MODEL 3000 FLOAT PARTS MANUAL

ASSY., MAIN GEAR (ALUM. GEAR)  
FIGURE 20

<u>REF</u> <u>NO.</u>	<u>NO.</u> <u>REQ.</u>	<u>PART DESCRIPTION</u>	<u>PART NO.</u>
	<b>1</b>	<b>ASS'Y., MAIN GEAR, RIGHT, HEAVY DUTY (185)</b>	<b>1004291-04</b>
	<b>1</b>	<b>ASS'Y., MAIN GEAR, LEFT, HEAVY DUTY (185)</b>	<b>1004251-04</b>
1	2	RETAINER, MAIN	1004263
2	1	ASS'Y., SHOCK, LIGHT DUTY, MAIN GEAR	1004286-04
6	1	ASS'Y., PIVOT PIN, SHOCK, UPPER, MAIN	1004287
7	1	ASSY, PIVOT, RH, MAIN GEAR	1004288
	1	ASS'Y., PIVOT, LH, MAIN GEAR	1005377
8	1	ASS'Y., UPPER SHOCK LINK	1004289
9	1	ASS'Y., SIDE SUPPORT, LH, MAIN	1004882
10	1	ASS'Y., SIDE SUPPORT, RH, MAIN	1005375
11	1	ASSEMBLY, SHAFT, UPPER SHOCK, MAIN GEAR	1005733
12	2	ASSEMBLY, BOLT, MODIFIED, LOWER PIVOT	1005734
13	1	ASSEMBLY, SUPPORT, PIVOT, LOWER, MAIN GEAR	1005735
14	1	ASS'Y., PIVOT PIN, SHOCK, LOWER, MAIN	1005750
15	4	COMMON GREASEZERK	1095K41
16	1	COMMON GREASEZERK	1095K42
17	1	BALL JOINT ROD END, 5/16" BALL ID, MALE	59915K273
18	1	BALL JOINT END, 5/16" BALL ID, FEMALE	59915K483
19	4	SEALING WASHER	93783A035
20	2	SEALING WASHER	93783A046
21	1	NUT	AN316-4R
22	2	NUT, HEX, SLOTTED , 7/8-14 UNF	AN320-14
23	6	BOLT	AN4-7A
24	1	BOLT	AN5-11A
25	2	NUT	MS21044N10
26	6	NUT	MS21044N4



WIPLINE MODEL 3000 FLOAT PARTS MANUAL

ASSY., MAIN GEAR (ALUM. GEAR)  
FIGURE 20

<u>REF</u> <u>NO.</u>	<u>NO.</u> <u>REQ.</u>	<u>PART DESCRIPTION</u>	<u>PART NO.</u>
27	1	NUT	MS21044N5
28	2	COTTER PIN	MS24665-304
20	12	WASHER	NAS1149F0463P
30	2	WASHER	NAS1149F0532P
31	2	COTTER PIN	NAS561P6-12

THIS PAGE INTENTIONALLY LEFT BLANK

WIPLINE MODEL 3450 FLOAT PARTS MANUAL

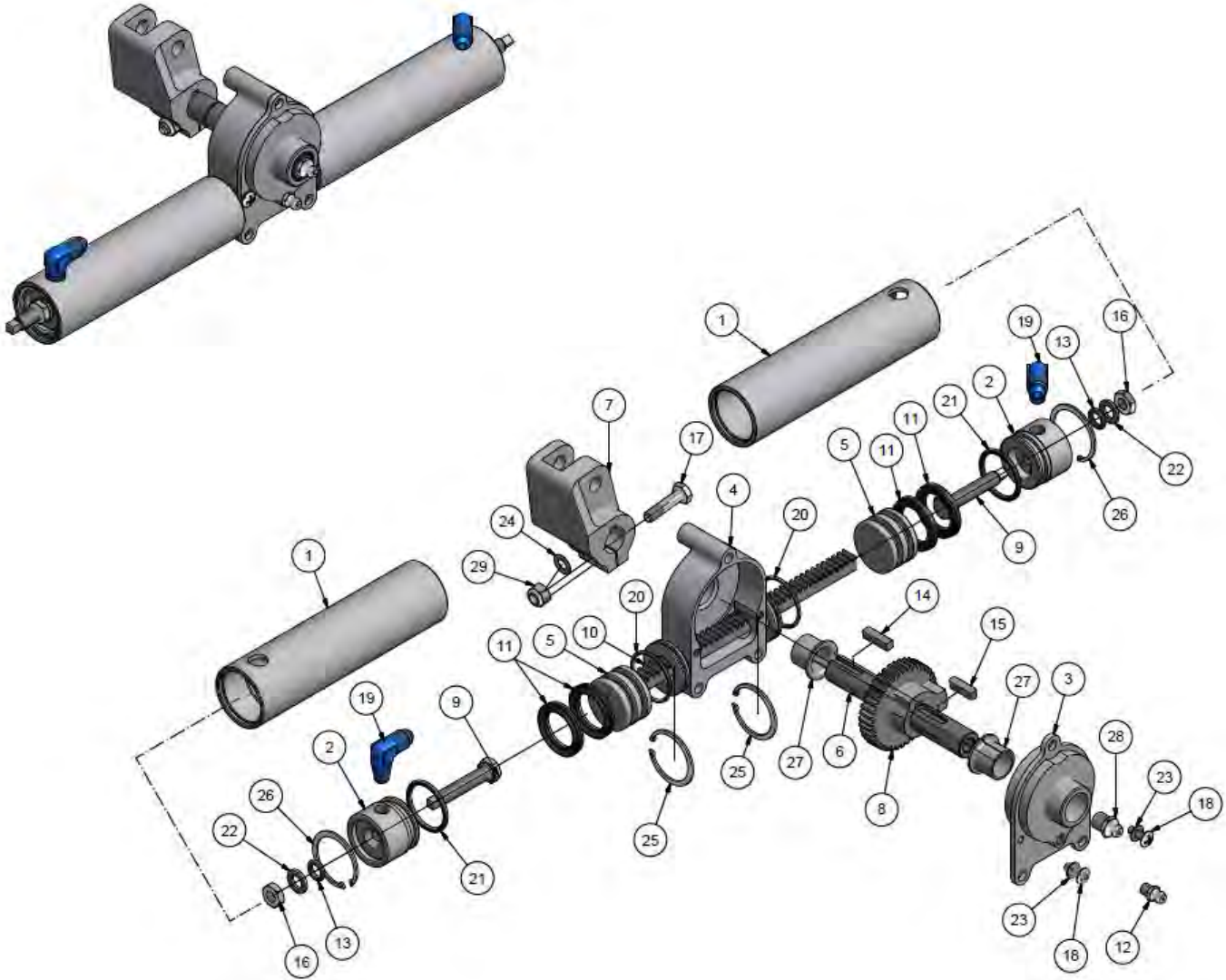

ASSEMBLY, ROTARY ACTUATOR, MAIN GEAR  
FIGURE 21

WIPLINE MODEL 3450 FLOAT PARTS MANUAL

ASSEMBLY, ROTARY ACTUATOR, MAIN GEAR

FIGURE 21

<u>REF</u> <u>NO.</u>	<u>NO.</u> <u>REQ.</u>	<u>PART DESCRIPTION</u>	<u>PART NO.</u>
	<b>1</b>	<b>ASSMEBLY, ROTARY ACUTATOR, MAIN GEAR</b>	<b>1005271</b>
1	2	CYLINDER, ROTARY ACTUATOR, MAIN GEAR	1005272
2	2	CYLINDER CAP, ROTARY ACTUATOR, MAIN GEAR	1005273
3	1	HOUSING TOP, ROTARY ACTUATOR, MAIN GEAR	1005274
4	1	HOUSING, ROTARY ACTUATOR, MAIN GEAR	1005275
5	2	PISTON, ROTARY ACTUATOR, MAIN GEAR	1005276
6	1	SHAFT, ROTARY ACTUATER, MAIN GEAR	1005277
7	1	ARM, GEAR ACTUATOR, 3000 3450	1005280
8	1	SPUR GEAR, PDIA 2.00 BORE .625 MODIFIED	1005282
9	2	BOLT, 5/16-24 UNF X 1.5, W/ 1/8 DRIVE, SST, MODIFIED	1005283
10	1	RACK, MOD, ROTARY ACTUATOR, MAIN GEAR	1005284
11	4	SEAL, U-CUP, .156 C/S, .937 ID, 1.250 OD, 90 DURO,	1005285
12	1	GREASE ZERK	1095K41
13	2	5018T168	5018T168
14	1	KEY, 3/16 X 3/16 X .75 LG, 1018 STL, .002 OVER SIZED	98870A330
15	1	KEY, 3/16 X 3/16 X .75 LG, 1018 STL, .002 OVER SIZED	98870A570
16	2	NUT	AN316C5R
17	1	BOLT	AN4-10A
18	2	SCREW, MACHINE, TRUSS HEAD	AN526C832R8
19	2	ELBOW	MS20822-4D
20	2	"O" RING	MS28775-024
21	2	"O" RING	MS28775-121
22	2	WASHER	NAS1149C0563R
23	2	WASHER	NAS1149CN832R
24	1	WASHER	NAS1149D0416J
25	2	RETAINING RING, INTERNAL	MS16625-4125
26	2	RETAINING RING, INTERNAL	MS16625-4131
27	2	FLANGED BUSHING	10FDU10
28	1	GREASE ZERK	1095K11
29	1	NUT	MS21044N4

# WIPLINE MODEL 3450 FLOAT PARTS MANUAL

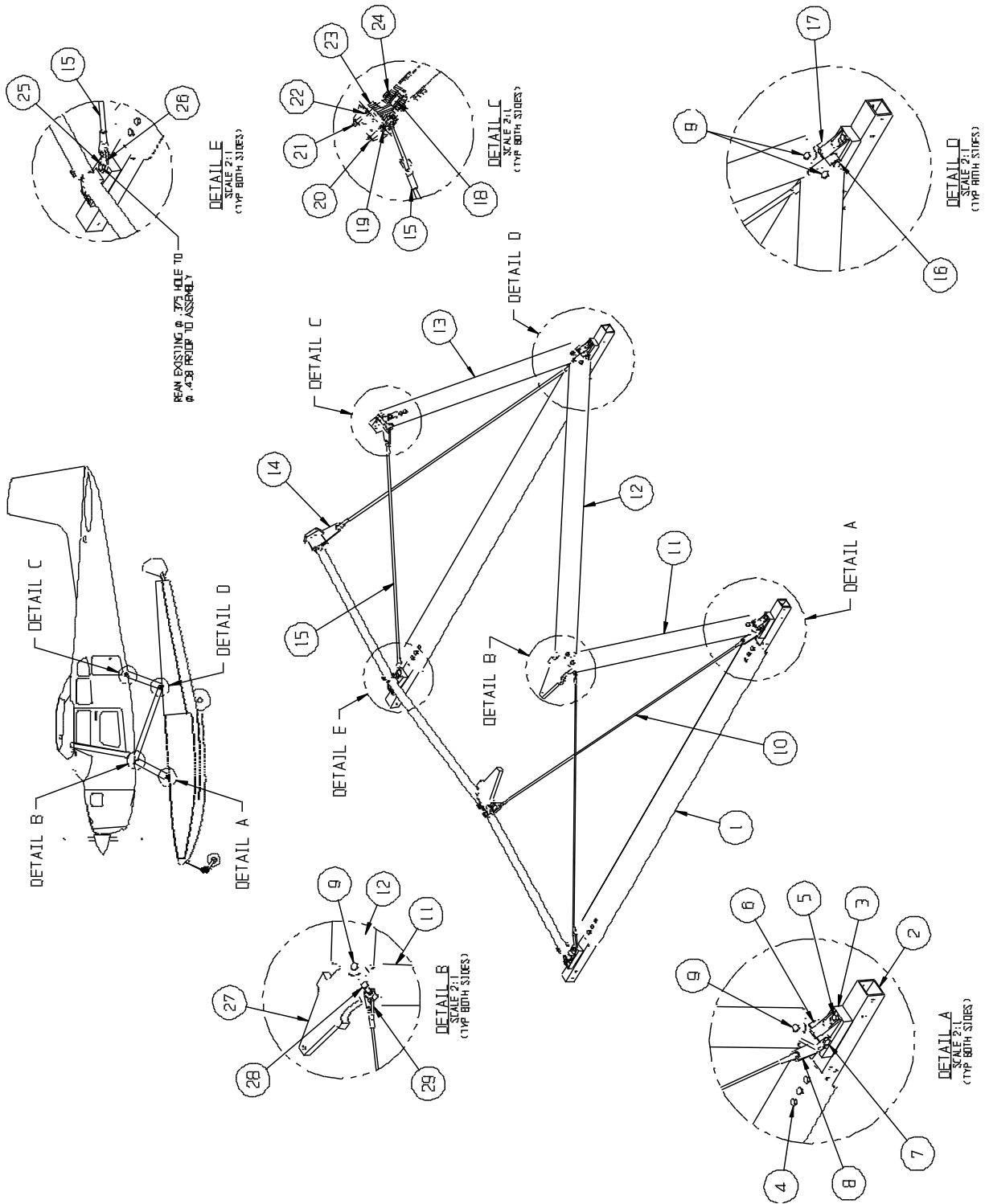

INSTALLATION – STRUTS, WIRES AND SPREADER BARS  
FIGURE 22

WIPLINE MODEL 3450 FLOAT PARTS MANUAL

INSTALLATION – STRUTS, WIRES, & SPREADER BARS, FIGURE 22

<u>REF NO.</u>	<u>NO.</u>	<u>REQ.</u>	<u>PART DESCRIPTION</u>	<u>PART NO.</u>
1	2		SPREADER BAR	30A03000-031
2	2		TUBE – SPREADER BAR – L. (SEE FIG 1 &2)	30A03319-001
	2		TUBE – SPREADER BAR – R. (SEE FIG 1 &2)	30A03319-002
3	4		FLOAT DECK FITTING	30A02219-003
4	12		BOLT – SPREADER BAR ATTACH	AN6-30A
	24		WASHER	NAS1149F0663P
	12		NUT	MS21044N6
5	4		BOLT – OUTBOARD ATTACH	AN6-41A
	8		WASHER	NAS1149F0663P
	4		NUT	MS21044N6
6	2		FITTING – LOWER FRONT	34A02204-015
7	2		BOLT – FITTING ATTACH	AN7-27A
	4		WASHER	NAS1149F763P
	2		NUT	MS21044N7
8	2		WIRE PULL - FWD	30A02462-016
	2		BOLT – ATTACH	AN6-43A
	4		WASHER	NAS1149F0663P
	2		NUT	MS21044N6
9	8		BOLT – STRUT ATTACH	AN7-20A
	16		WASHER	NAS1149F0763P
	8		NUT	MS21044N7
10	2		ASS'Y – FRONT DRAG WIRE	3A02000-044
	2		PIN - CLEVIS	MS20392-5C21
	2		PIN - COTTER	MS24665-301
	1		CLEVIS “L”	AN665-80LAS *

\* “S” DENOTES STAINLESS STEEL

WIPLINE MODEL 3450 FLOAT PARTS MANUAL

INSTALLATION – STRUTS, WIRES, & SPREADER BARS, FIGURE 22

<u>REF NO.</u>	<u>NO.</u>	<u>REQ.</u>	<u>PART DESCRIPTION</u>	<u>PART NO.</u>
	1		CLEVIS “R”	AN665-80RAS *
	1		CHECK NUT “L”	AN316C6L
	1		CHECK NUT “R”	AN316C6R
11	1		ASS’Y – FWD STRUT - LH	34A02000-229
	1		ASS’Y – FWD STRUT – RH	34A02000-204
12	2		ASS’Y – CENTER STRUT	34A02000-205
13	1		ASS’Y – REAR STRUT - LH	34A02000-207
	1		ASS’Y – REAR STRUT - RH	34A02000-206
14	1		WIRE PULL – UPPER REAR - LH	4A02079-003
	1		WIRE PULL – UPPER REAR – RH	4A02079-004
15	2		ASS’Y – REAR DRAG WIRE	34A02000-208
	2		PIN - COTTER	MS24665-370
	2		PIN - CLEVIS	MS20392-6C25
	1		CLEVIS “L”	AN665-115LS *
	1		CLEVIS “R”	AN665-115RS *
	1		CHECK NUT “L”	AN316C7L
	1		CHECK NUT “R”	AN316C7R
16	2		BOLT – RH LOWER – FITTING ATTACH	AN7-32A
	4		WASHER	NAS1149F0763P
	2		NUT	MS21044N7
17	1		FITTING – AFT LOWER - LH	34A02207-007
	1		FITTING – AFT LOWER – RH	34A02207-006
18	2		BEARING - STRUT	COM-8
	2		RETAINER RING	N5000-100H
19	2		BOLT – FITTING ATTACH	AN5-17A
	2		WASHER	NAS1149F0563P

\* “S” DENOTES STAINLESS STEEL

WIPLINE MODEL 3450 FLOAT PARTS MANUAL

INSTALLATION – STRUTS, WIRES, & SPREADER BARS, FIGURE 22

<u>REF NO.</u>	<u>NO. REQ.</u>	<u>PART DESCRIPTION</u>	<u>PART NO.</u>
	2	NUT	MS21044N5
20	2	BOLT – STRUT ATTACH	AN5-34A
	2	WASHER	NAS1149F0563P
	2	NUT	MS21044N5
21	2	BOLT – STRUT ATTACH	AN5-31A
	2	WASHER	NAS1149F0563P
	2	NUT	MS21044N5
22	2	BOLT – FITTING ATTACH	AN5-12A
	2	WASHER	NAS1149F0563J
	2	NUT	MS21044N5
23	1	FITTING – UPPER REAR - LH	4A02370-001
	1	FITTING – UPPER REAR - RH	4A02370-002
24	2	BOLT - ATTACH	AN8-22A
	4	WASHER	NAS1149F0863P
	2	NUT	MS21044N8
25	2	BOLT – REAR LUG ATTACH	AN7-43A
	4	WASHER	NAS1149F0763P
	2	NUT	MS20365-720A
26	2	WIRE PULL – REAR	34A02496-003
27	1	FITTING – UPPER FWD – LH	34A02062-015
	1	FITTING – UPPER FWD – RH	34A02062-014
28	2	BOLT – UPPER WIRE ATTACH	AN7-20A
	2	WASHER	NAS1149F0763P
29	1	FITTING – UPPER DRAG WIRE - LH	4A02000-071
	1	FITTING – UPPER DRAG WIRE – RH	4A02000-072



# WIPLINE MODEL 3450 FLOAT PARTS MANUAL

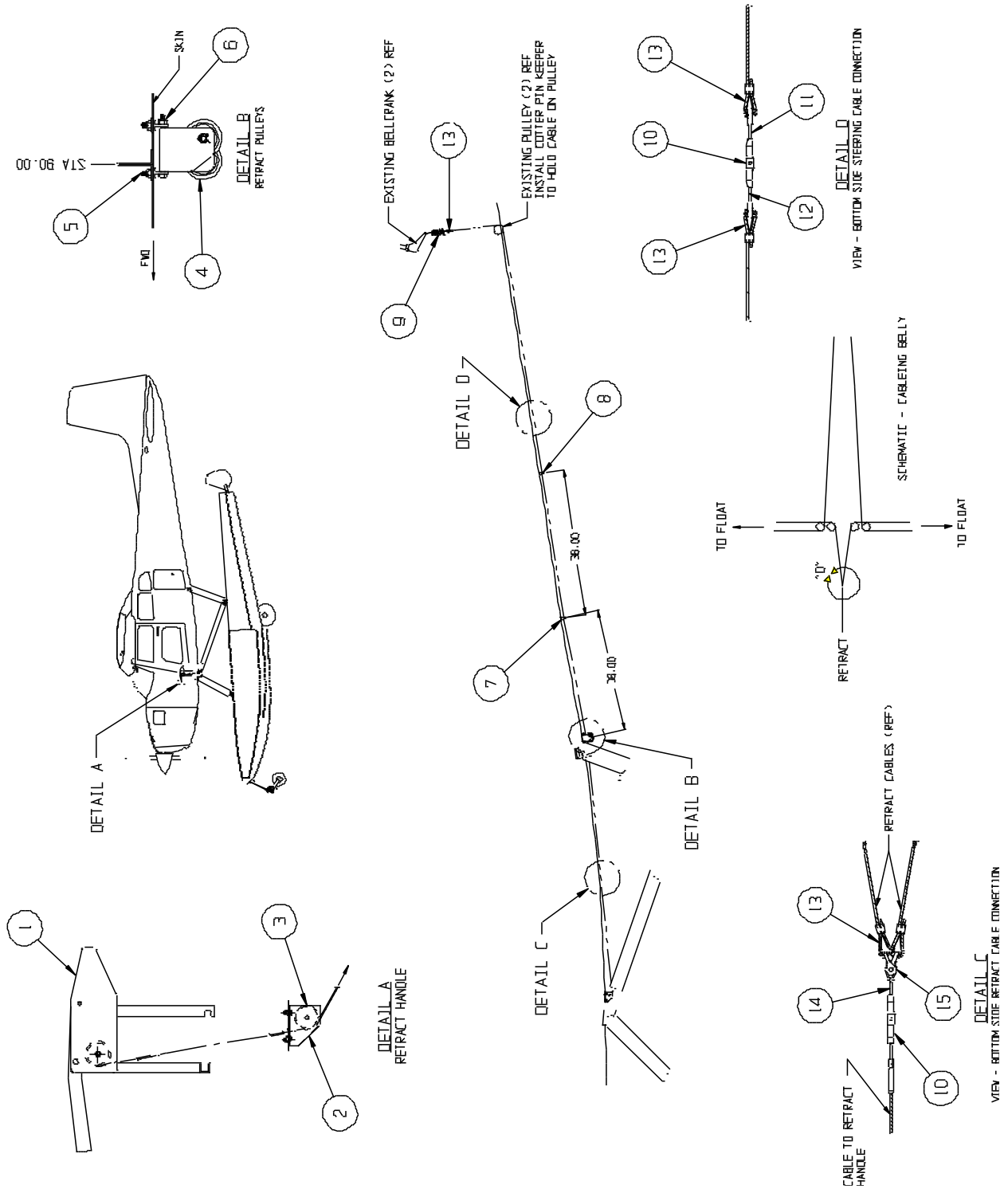

INSTALLATION – STEERING AND RETRACT SYSTEM  
FIGURE 23

WIPLINE MODEL 3450 FLOAT PARTS MANUAL

INSTALLATION – STEERING AND RETRACT SYSTEM, FIGURE 23

<u>REF NO.</u>	<u>NO.</u>	<u>REQ.</u>	<u>PART DESCRIPTION</u>	<u>PART NO.</u>
1	1		ASS'Y – RETRACT HANDLE COMPLETE (SEE FIGURE 23)	4A08000-087
2	1		PULLEY BRACKET	3A08151-046
	4		BOLT	AN526-1032R8
	4		WASHER	NAS1149D0316J
	4		NUT	MS21044N3
3	1		PULLEY	MS20219-2
	1		BOLT	AN4-10A
	1		WASHER	NAS1149D0463J
	1		NUT	MS21044N4
4	4		PULLEY BRACKET	4A08151-093
	4		PULLEY	MS20219-2
	4		BOLT	AN4-10A
	8		WASHER	NAS1149D0463J
	4		NUT	MS21044N4
5	8		EYEBOLT	AN42-4A
	8		WASHER	NAS1149D0363J
	4		WASHER	AN970-3
6	8		NUT	MS21044N3
	4		BOLT – BRACKET TO EYEBOLT	AN3-25A
	4		WASHER	NAS1149D0316J
7	4		NUT	MS21044N3
	2		CABLE GUIDE HOLDER	4A08153-010
8	2		GUIDE	3A08601-003
	2		CABLE GUIDE HOLDER	4A08153-010
9	2		SPRING	0742016-1

WIPLINE MODEL 3450 FLOAT PARTS MANUAL

INSTALLATION – STEERING AND RETRACT SYSTEM, FIGURE 23

<u>REF NO.</u>	<u>NO.</u>	<u>PART DESCRIPTION</u>	<u>PART NO.</u>
<u>NO.</u>	<u>REQ.</u>		
10	3	TURNBUCKLE - BARREL	MS21251B3S
11	2	EYE - TERMINAL	AN170-16RS
12	2	EYE - TERMINAL	MS21255-3LS
	A/R	THIMBLE	AN100-3
13	A/R	NICOPRESS	18-2-G
14	1	FORK – TERMINAL	MS21252-3RS
15	2	SHACKLE	MS20115-3
	1	PIN – CLEVIS	MS20392-2-19

THIS PAGE INTENTIONALLY LEFT BLANK

WIPLINE MODEL 3450 FLOAT PARTS MANUAL

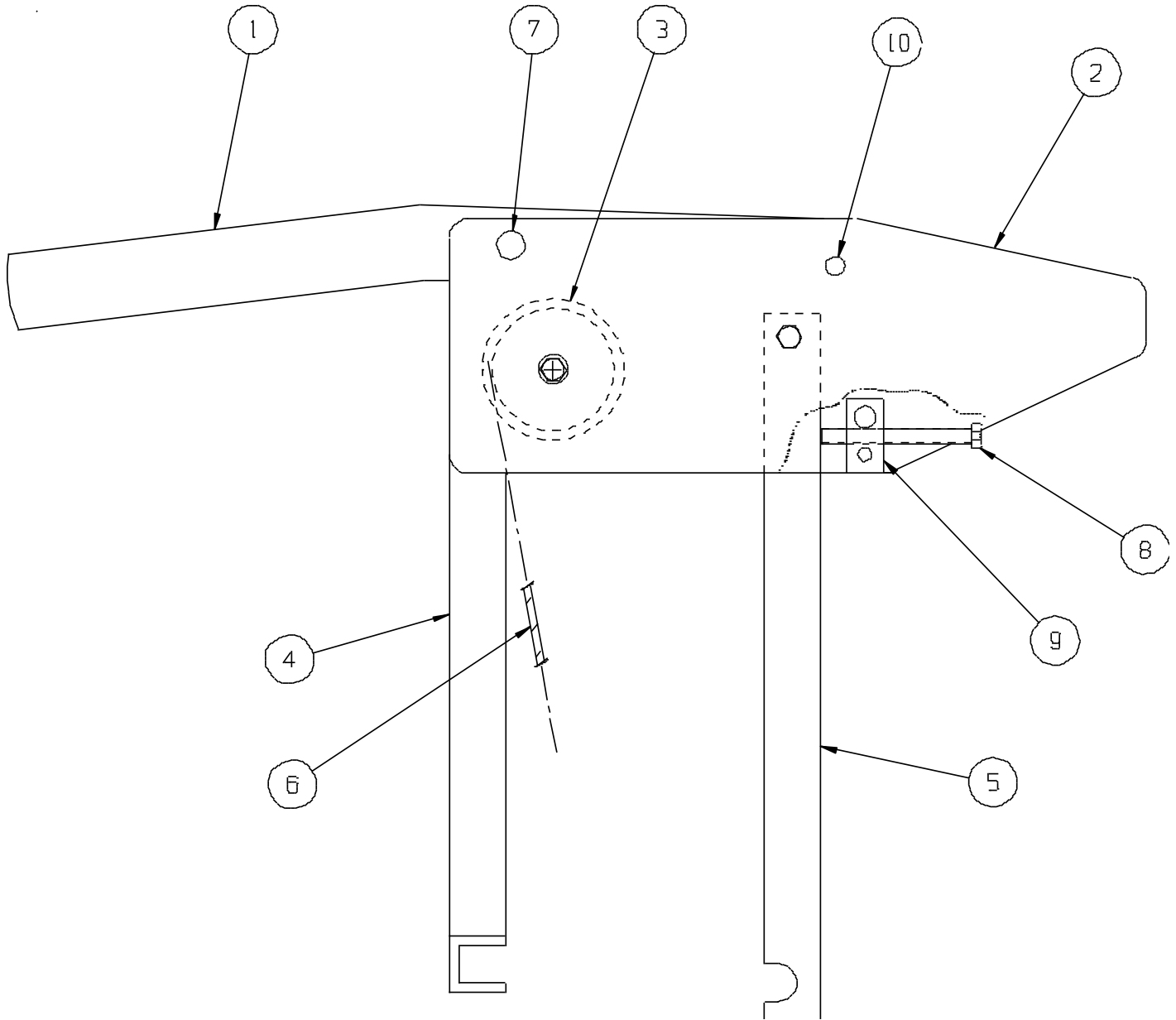

ASSEMBLY - RETRACT HANDLE  
FIGURE 24

## WIPLINE MODEL 3450 FLOAT PARTS MANUAL

## ASSEMBLY- RETRACT HANDLE, FIGURE 24

<u>REF NO.</u>	<u>NO.</u>	<u>REQ.</u>	<u>PART DESCRIPTION</u>	<u>PART NO.</u>
	1		ASS'Y – RETRACT HANDLE	4A08000-087
1	1		HANDLE	4A08414-003
2	2		SIDE PLATE	3A08003-017
3	1		PULLEY	MS20219-2
	1		BOLT – ATTACH	AN4-10A
	2		WASHER	NAS1149DO463P
	2		WASHER	NAS1149DO432P
	1		NUT	H10-4
4	1		LEG - FWD	3A08000-007
5	1		LEG - AFT	3A08415-001
6	1		CABLE ASS'Y	3A08000-051
7	1		CABLE - SWIVEL	4A08506-002
8	1		SCREW - ADJUSTING	10-32 X 2 S.S. HEX
9	1		BLOCK – ADJUSTING	3A08061-003
10	2		PIVOT PIN	3A08702-006
	2		WASHER	NAS1149F0332P
	2		NUT	H10-3

WIPLINE MODEL 3450 FLOAT PARTS MANUAL

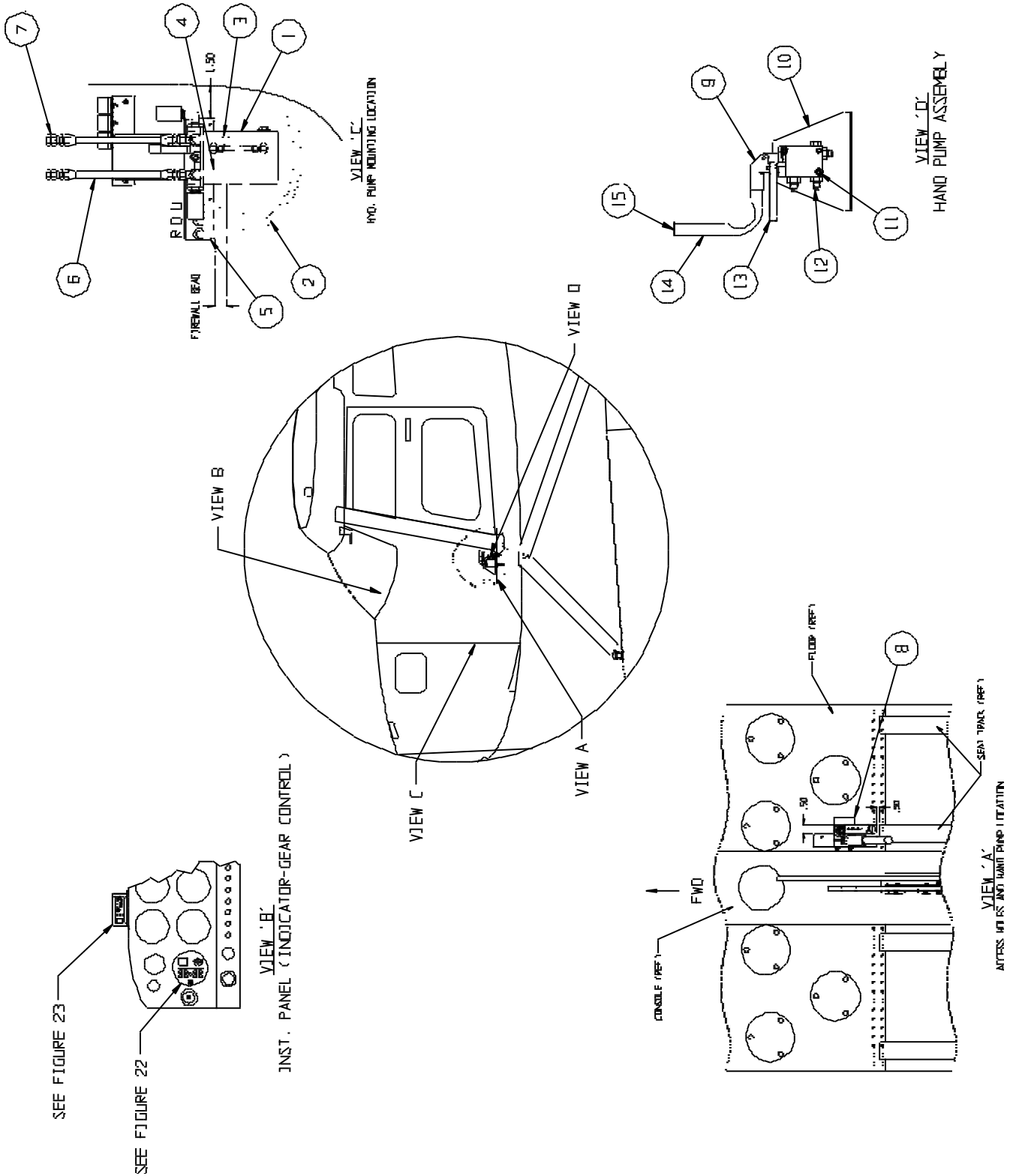

INSTALLATION – HYDRAULIC SYSTEM  
FIGURE 25

WIPLINE MODEL 3450 FLOAT PARTS MANUAL

INSTALLATION – HYDRAULIC SYSTEM, FIGURE 25

<u>REF NO.</u>	<u>NO.</u>	<u>REQ.</u>	<u>PART DESCRIPTION</u>	<u>PART NO.</u>
1	1		ASS'Y – HYDRAULIC PUMP (12V)	34A09000-266
2	1		ASS'Y – HYDRAULIC PUMP (24V)	34A09000-281
3	1		ASS'Y – HYDRAULIC HOSE	34A09000-246
4	1		ASS'Y – HYDRAULIC HOSE	34A09000-247
5	1		ASS'Y – HYDRAULIC HOSE	34A09000-248
	1		ANGLE – PUMP MOUNT	34A09357-074
	4		RIVET - ATTACH	CR3243-4-3
	2		SPACER	3A09271-001
	2		BOLT - ATTACH	3A09702-012
6	4		WASHER	NAS1149FO663P
7	2		ASS'Y – HOSE ACCUMULATOR	8A09000-048
8	2		PLUG	AN806-4D
9	1		ASS'Y – HAND PUMP (COMPLETE)	34A09000-267
10	1		HAND PUMP ONLY	638203
11	1		BRACKET	34A09156-166
	3		CAP SCREW	5/16-18UNC-2B X .63
	3		WASHER	MS35333-40
12	3		WASHER	NAS1149FO563J
	3		UNION	AN815-4D
13	3		“O” RING	MS28775-011
14	1		ASS'Y – HANDLE SELECTOR	21A12000-052
15	1		HANDLE - PUMP	21A09396-001
	1		CAP PLUG	9283K13



WIPLINE MODEL 3450 FLOAT PARTS MANUAL

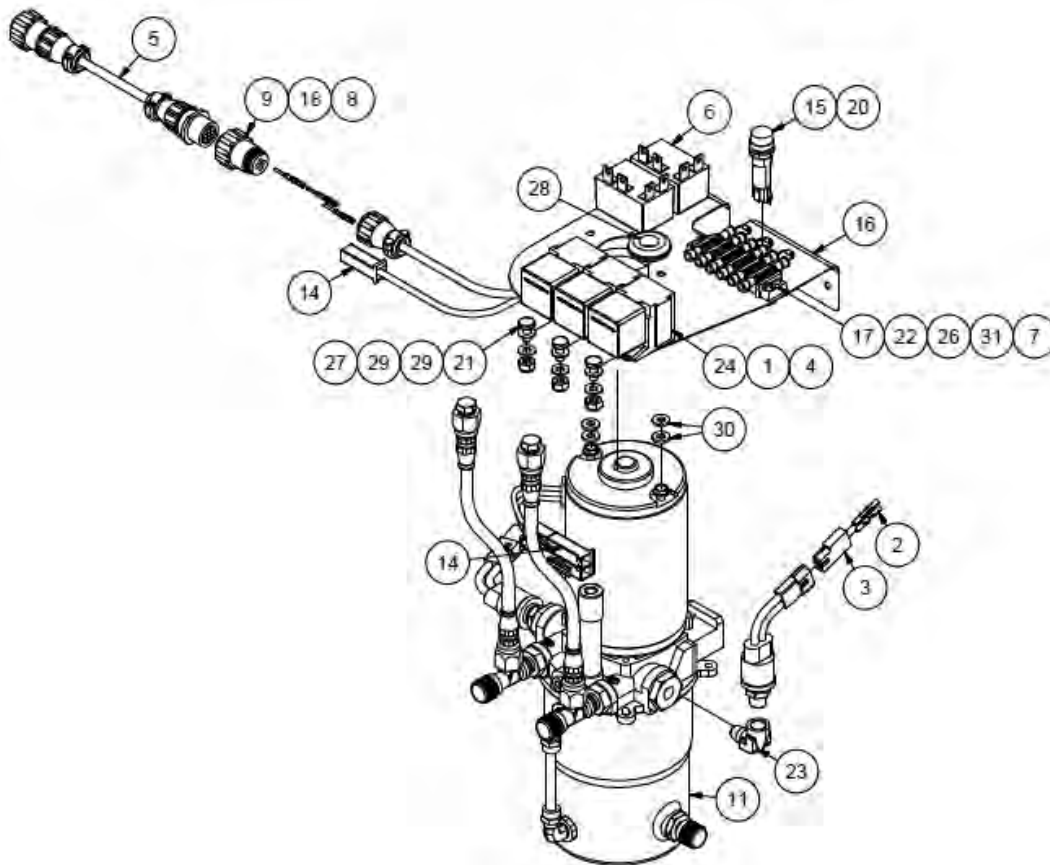
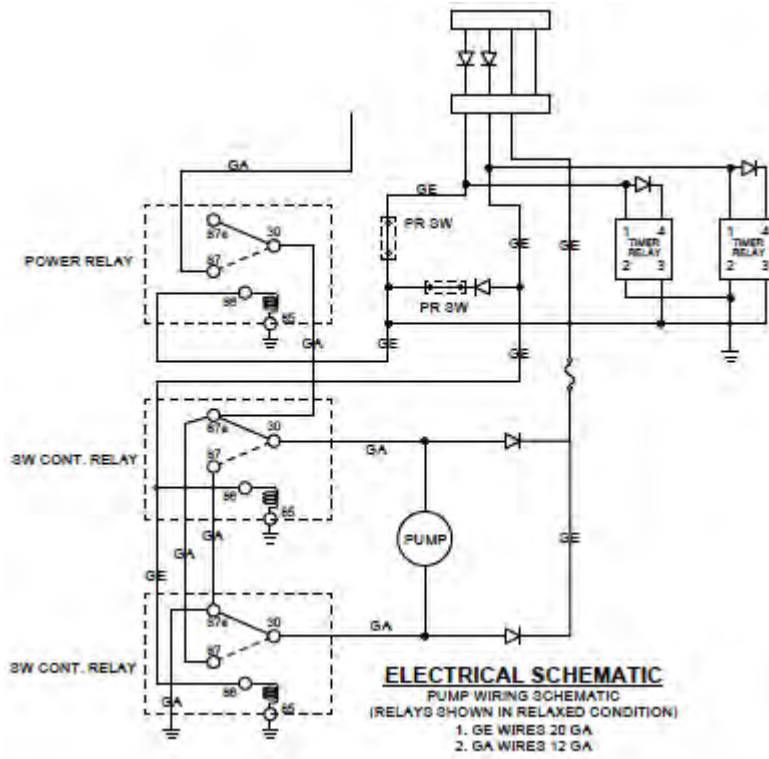

ASSEMBLY – HYDRAULIC PUMP  
 FIGURE 26

WIPLINE MODEL 3450 FLOAT PARTS MANUAL

ASSEMBLY – HYDRAULIC PUMP, FIGURE 26

<u>REF NO.</u>	<u>NO.</u>	<u>PART DESCRIPTION</u>	<u>PART NO.</u>
1	3	RELAY, 12V, 5 PRONG	0-332-209-137
	3	RELAY, 24V, 5 PRONG	0-332-209-211
2	4	PIN, CRIMP FEMALE, 1/8" DIA	02-09-1104
3	2	CONNECTOR PLUG, MALE, 2 CONN.	03-09-1022
4	14	TERMINAL	1-901-355-917
5	1	CABLE, DIODE ADAPTOR	1004949
6	1	TIMER RELAY HARNESS 12V	1005042
	1	TIMER RELAY HARNESS 24V	1005043
7	3	DIODE, 2-1/2"	1N4004
8	2	CLAMP, CABLE, CPC SIZE 11	206062-3
9	1	PLUG, MALE, CPC SIZE 1, 4 PIN	206429-1
10	1	CPC FREE HANG, 4 PIN, FEMALE	206430-2
11	1	ASSEMBLY, HYDRAULIC PUMP, 12V	21A09000-215
	1	ASSEMBLY, HYDRAULIC PUMP, 24V	21A09000-282
12	6 FT	WIRE, 12 AWG, WHITE	22759-16-12-9
13	10.1 FT	WIRE, 20 AWG, WHITE	22759-16-20-9
14	3	HOUSING CONNECTOR ASSEMBLY	2601048-200
15	1	FUSE HOLDER	3453LF2A
16	1	BRACKET - HYD. PUMP	34A09005-291
17	1	TERMINAL BLOCK, 6 CONNECTOR	6-140

## WIPLINE MODEL 3450 FLOAT PARTS MANUAL

## ASSEMBLY – HYDRAULIC PUMP, FIGURE 26

<u>REF NO.</u>	<u>NO.</u>	<u>REQ.</u>	<u>PART DESCRIPTION</u>	<u>PART NO.</u>
18	3		PIN, CRIMP SOCKET, 24-20G	66103-4
19	3		CRIMP SOCKET, FEMALE	66105-4
20	1		FUSE, 250V, (S2565-1)	AGC-1
21	3		BOLT	AN3-3A
22	2		SCREW, MACHINE, TRUSS HEAD	AN526-632R8
23	1		ELBOW,90°, INTERNALEXTERNAL PIPE	AN914-1D
24	3		SOCKET, 5 PRONG, PLASTIC	BR05FW
25	1.5 FT		HEAT SHRINK, TUBING, BLACK	HS105-3/16-0
26	2		NUT	MS21044N06
27	3		NUT	MS21044N3
28	1		GROMMET	MS35489-14
29	6		WASHER	NAS1149F0332P
30	4		WASHER	NAS1149F0363P
31	12		RING CONNECTOR	R-3
32	1		ANGLE - PUMP MOUNT (NOT SHOWN)	34A09357-074

THIS PAGE INTENTIONALLY LEFT BLANK

WIPLINE MODEL 3450 FLOAT PARTS MANUAL

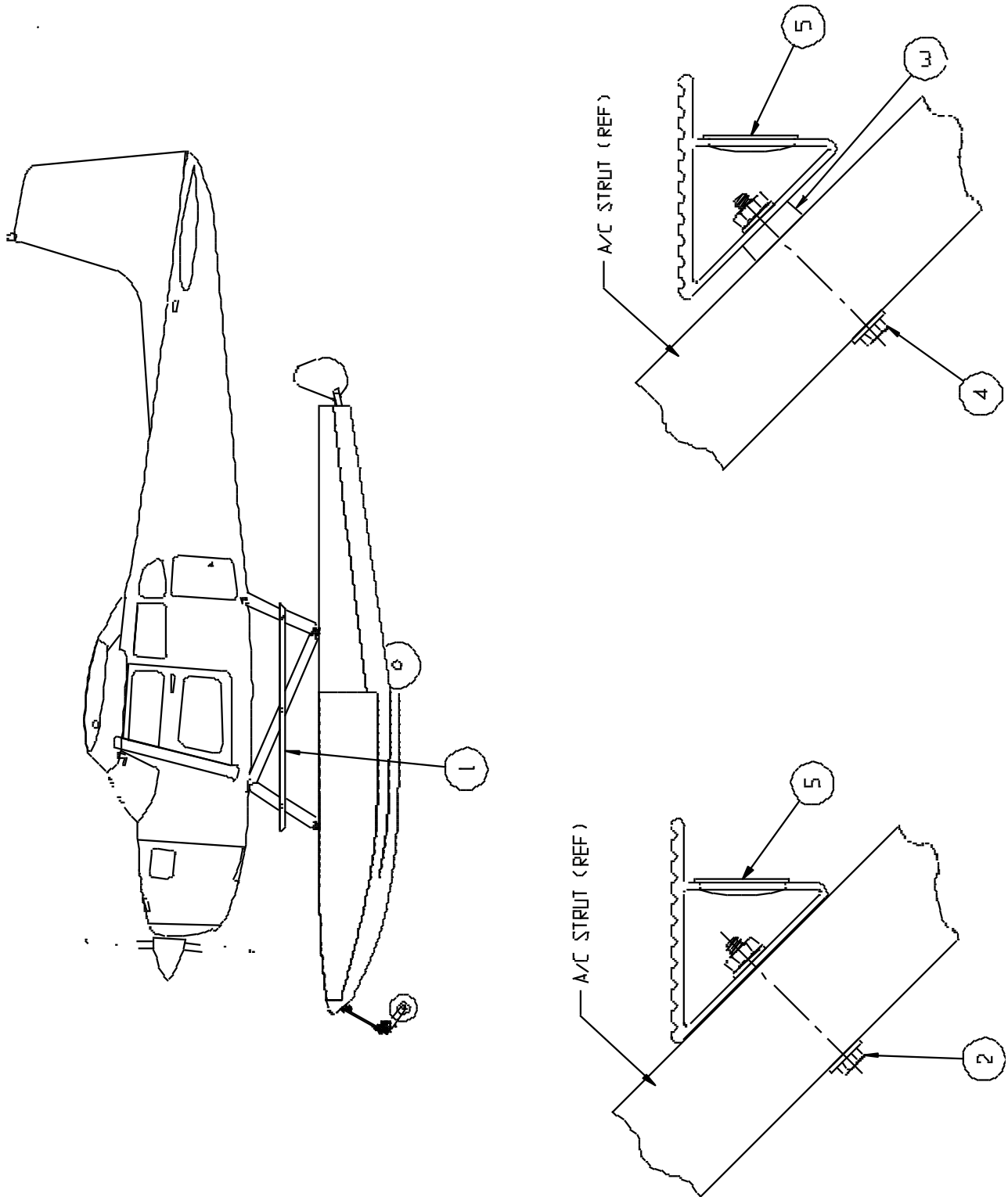

INSTALLATION STEPS  
FIGURE 27

WIPLINE MODEL 3450 FLOAT PARTS MANUAL

INSTALLATION STEPS, FIGURE 27

<u>REF NO.</u>	<u>NO.</u>	<u>REQ.</u>	<u>PART DESCRIPTION</u>	<u>PART NO.</u>
1	1		STEP - L.H.	34A02369-051
	1		STEP – R.H.	34A02369-050
2	2		BOLT – CENTER ATTACH	AN3-21A
	4		WASHER	NAS1149F0363P
	2		NUT	MS21044N3
3	4		SPACER – FRONT & REAR	6A02273-006
4	4		BOLT – FRONT & REAR ATTACH	AN3-24A
	8		WASHER	NAS1149F0363P
	4		NUT	MS21044N3
5	6		HOLE PLUG, 1”	BPF

WIPLINE MODEL 3450 FLOAT PARTS MANUAL

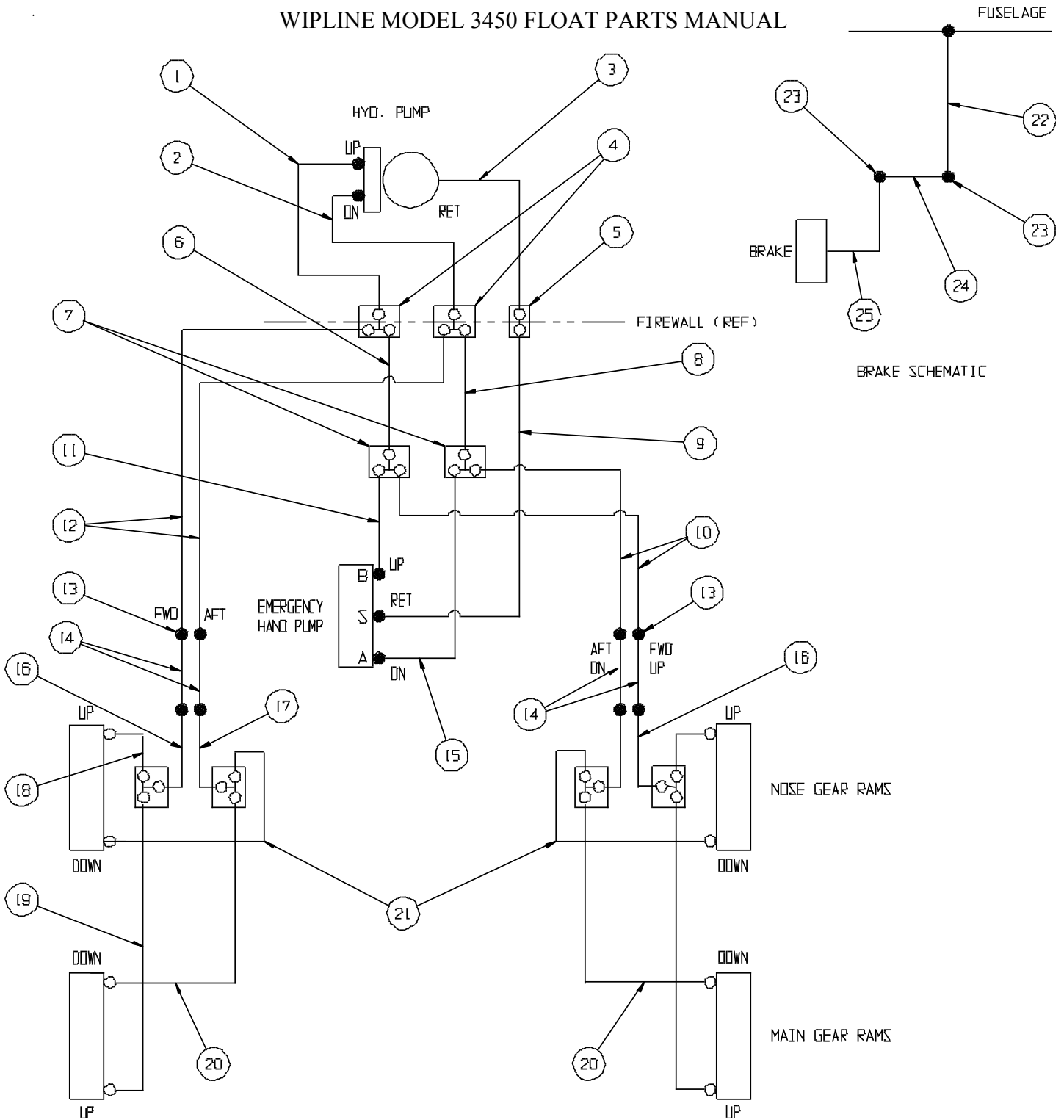

HYDRAULIC SCHEMATIC – PUMP  
FIGURE 28

1	1	ASS'Y – HYDRAULIC HOSE	34A09000-248
2	1	ASS'Y – HYDRAULIC HOSE	34A09000-247
3	1	ASS'Y – HYDRAULIC HOSE	34A09000-246
4	2	“T” FITTING	AN804-4D
	2	NUT	AN924-4D
	2	WASHER	NAS1149F0763P
5	1	UNION FITTING	AN832-4D
	1	NUT	AN924-4D
	1	WASHER	NAS1149F0763P
6	1	ASS'Y – HYDRAULIC HOSE	34A09000-254
7	2	“T” FITTING	AN824-4D
8	1	ASS'Y – HYDRAULIC HOSE	34A09000-253
9	1	ASS'Y – HYDRAULIC HOSE	34A09000-252
10	2	ASS'Y – HYDRAULIC HOSE	34A09000-249
11	1	ASS'Y – HYDRAULIC HOSE	34A09000-250
12	2	ASS'Y – HYDRAULIC HOSE	34A09000-255
13	4	ELBOW FITTING	AN833-4D
	4	NUT	AN924-4D
	4	WASHER	NAS1149F0763P
14	4	ASS'Y – HYDRAULIC HOSE (W/ SK 66 and/or SN 30154 and lower)	21A09000-206
	4	ASS'Y – HYDRAULIC HOSE (W/O SK 66 and/or SN 30155 and up)	1002482
15	1	ASS'Y – HYDRAULIC HOSE	34A09000-251
16	2	ASS'Y – HYDRAULIC HOSE	30A09000-272



WIPLINE MODEL 3450 FLOAT PARTS MANUAL

HYDRAULIC SCHEMATIC – PUMP, FIGURE 28

<u>REF NO.</u>	<u>NO.</u>	<u>REQ.</u>	<u>PART DESCRIPTION</u>	<u>PART NO.</u>
17	2		ASS'Y - HYDRAULIC HOSE	30A09000-273
18	2		ASS'Y – HYDRAULIC HOSE	30A09000-268
19	2		ASS'Y – HYDRAULIC HOSE	34A09000-274
20	2		ASS'Y – HYDRAULIC HOSE	34A09000-275
21	2		ASS'Y – HYDRAULIC HOSE	30A09000-269
22	2		ASS'Y – HYDRAULIC HOSE	21A09000-080
	2		FITTINGS – END	63-190600-3
23	2		FITTING – ELBOW	AN833-3D
	4		WASHER	NAS1149DO663J
	2		NUT	AN924-3D
24	2		LINE ASS'Y – HARD	21A04000-079
25	2		LINE ASS'Y – FLEX	21A04000-078

THIS PAGE INTENTIONALLY LEFT BLANK

# WIPLINE MODEL 3450 FLOAT PARTS MANUAL

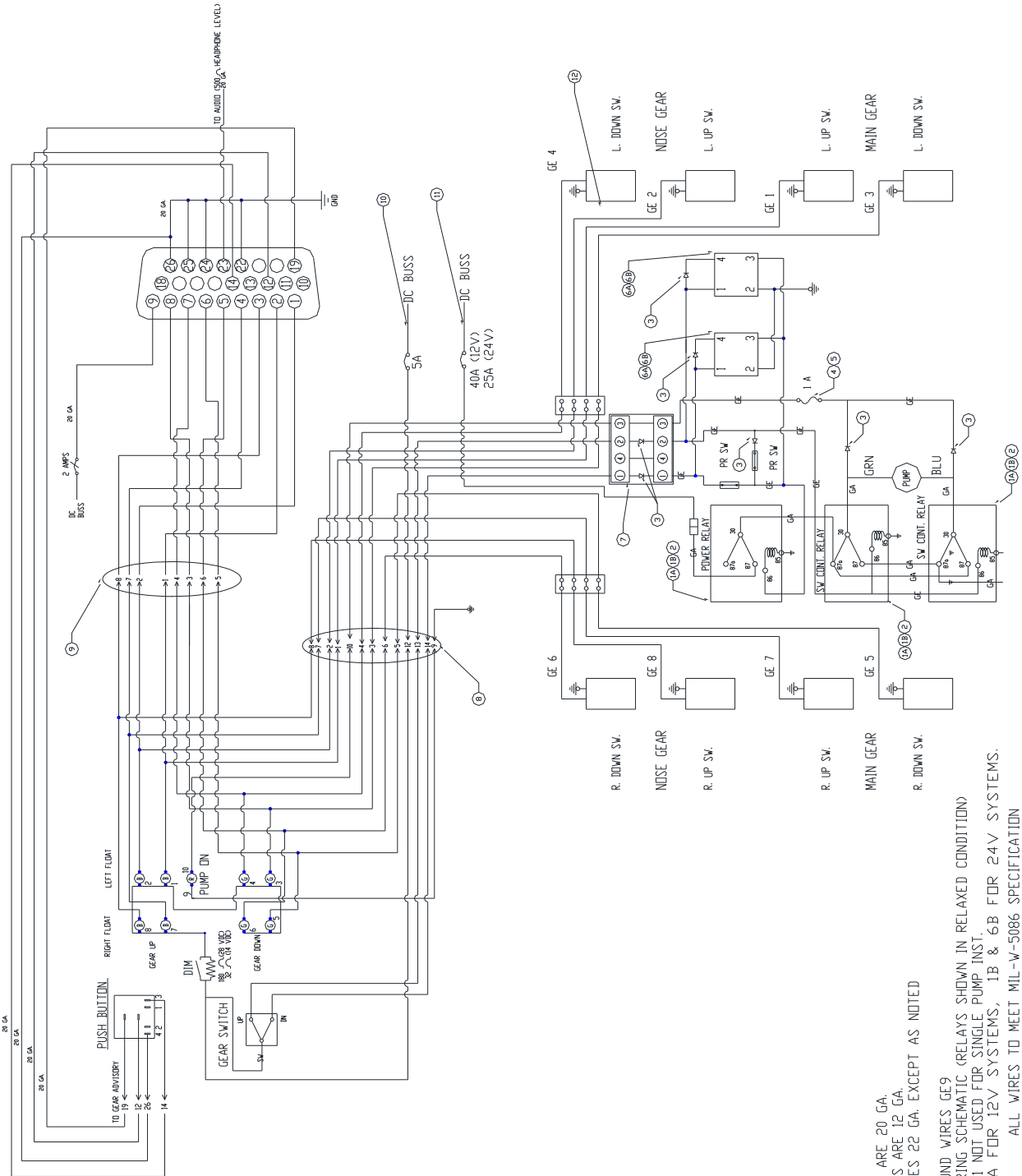

- NOTES:
1. GE WIRES ARE 20 GA.  
GA WIRES ARE 12 GA.  
ALL WIRES 22 GA. EXCEPT AS NOTED
  2. ALL GROUND WIRES GE9
  3. PUMP WIRING SCHEMATIC (RELAYS SHOWN IN RELAXED CONDITION)
  4. ONE GE 11 NOT USED FOR SINGLE PUMP INST.
  5. 1A & 6A FOR 12V SYSTEMS, 1B & 6B FOR 24V SYSTEMS.  
ALL WIRES TO MEET MIL-W-5086 SPECIFICATION

ELECTRICAL SCHEMATIC  
FIGURE 29

WIPLINE MODEL 3450 FLOAT PARTS MANUAL

ELECTRICAL SCHEMATIC, FIGURE 29

<u>REF NO.</u>	<u>NO.</u>	<u>REQ.</u>	<u>PART DESCRIPTION</u>	<u>PART NO.</u>
1A	3		RELAY 12V	0-332-209-211
1B	3		RELAY 24V	0-332-209-137
2	3		RELAY SOCKET	BR05FW
3	7		DIODE	1N4004
4	1		FUSE 1 AMP	AGC-1
5	1		FUSE HOLDER	3453LF2A
6A	1		ASSEMBLY, TIMER RELAY 12V	1005042
6B	2		ASSEMBLY, TIMER RELAY 24V	1005043
7	1		DIODE CABLE ADAPTOR	1004949
8	1		WIRE HARNESS	4A11000-014
9	1		WIRE HARNESS	4A11000-012
10	1		CIRCUIT BREAKER	5 AMP
11	1		CIRCUIT BREAKER (12V)	40 AMP
	1		CIRCUIT BREAKER (24V)	25 AMP
12	8		SWITCH – PROXIMITY - MAGNETIC	5801
	8		CLIP – SWITCH HOLDER	21A09005-262

# WIPLINE MODEL 3450 FLOAT PARTS MANUAL

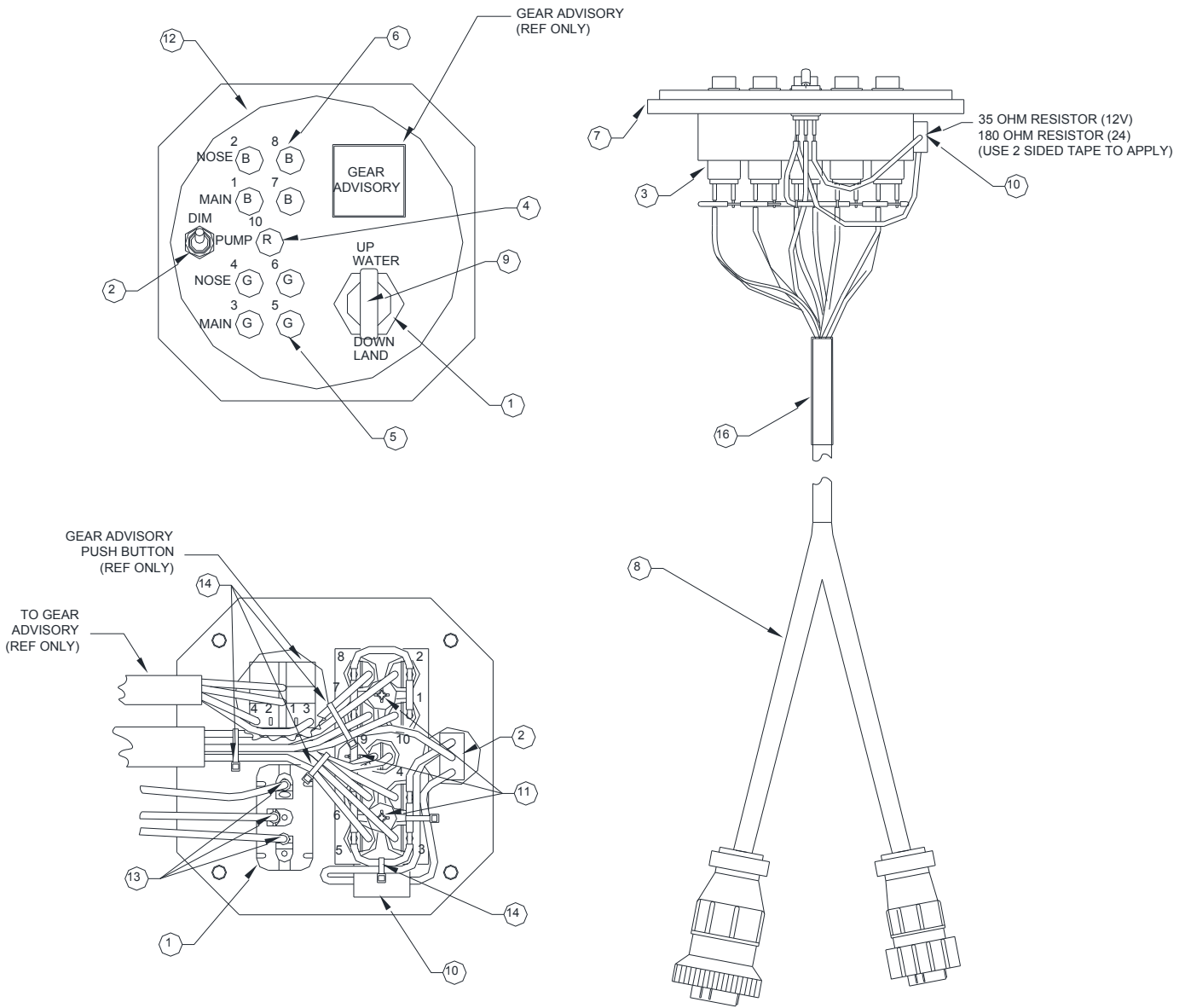

GEAR CONTROL (ROUND)  
FIGURE 30

## WIPLINE MODEL 3450 FLOAT PARTS MANUAL

## GEAR CONTROL (ROUND), FIGURE 30

<u>REF NO.</u>	<u>NO.</u>	<u>REQ.</u>	<u>PART DESCRIPTION</u>	<u>PART NO.</u>
	1		GEAR SELECTOR ASSY. ROUND (12V)	21A11000-009
	1		GEAR SELECTOR ASSY. ROUND (24V)	21A11000-019
1	1		SWITCH	8857K44
2	1		TOGGLE SWITCH, SPDT, ON-ON	A101SYCB
3	9		SOCKET	515-0012
4	1		INDICATOR LAMP, 14V, RED	507-3914-1431-600
	1		INDICATOR LAMP, 28V, RED	507-3918-1431-600
5	4		INDICATOR LAMP, 14V, GREEN	507-3914-1432-600
	4		INDICATOR LAMP, 28V, GREEN	507-3918-1432-600
6	4		INDICATOR LAMP, 14V, BLUE	507-3914-1434-600
	4		INDICATOR LAMP, 28V, BLUE	507-3918-1434-600
7	1		BLOCK, GEAR CONTROL	21A11179-001
8	1		HARNESS ASSEMBLY, GEAR SELECTOR	4A11000-008
9	1		GEAR SWITCH KNOB	21A11259-003
10	1		RESISTOR, 14V, DALE RH5 5W	RH-5-35
	1		RESISTOR, 28V, DALE RH5 5W	RH-5-180
11	3		SCREW, TRUSS HEAD, 6-32	AN526-632R8
12	1		PLACARD, ROUND2100 GEAR SELECTOR	10B3-6202
13	3		RING CONNECTOR, #6, 20 AWG, RED	R-3
14	5		CABLE TIE	PLT1M-M
15	16"		SHRINK WRAP, 3/16, WHITE	HIXR-3/16
16	3"		HEAT SHRINK TUBING	HS105-1/2-0
17	6"		WIRE, 20AWG, WHITE	22759-16-20-9

# WIPLINE MODEL 3450 FLOAT PARTS MANUAL

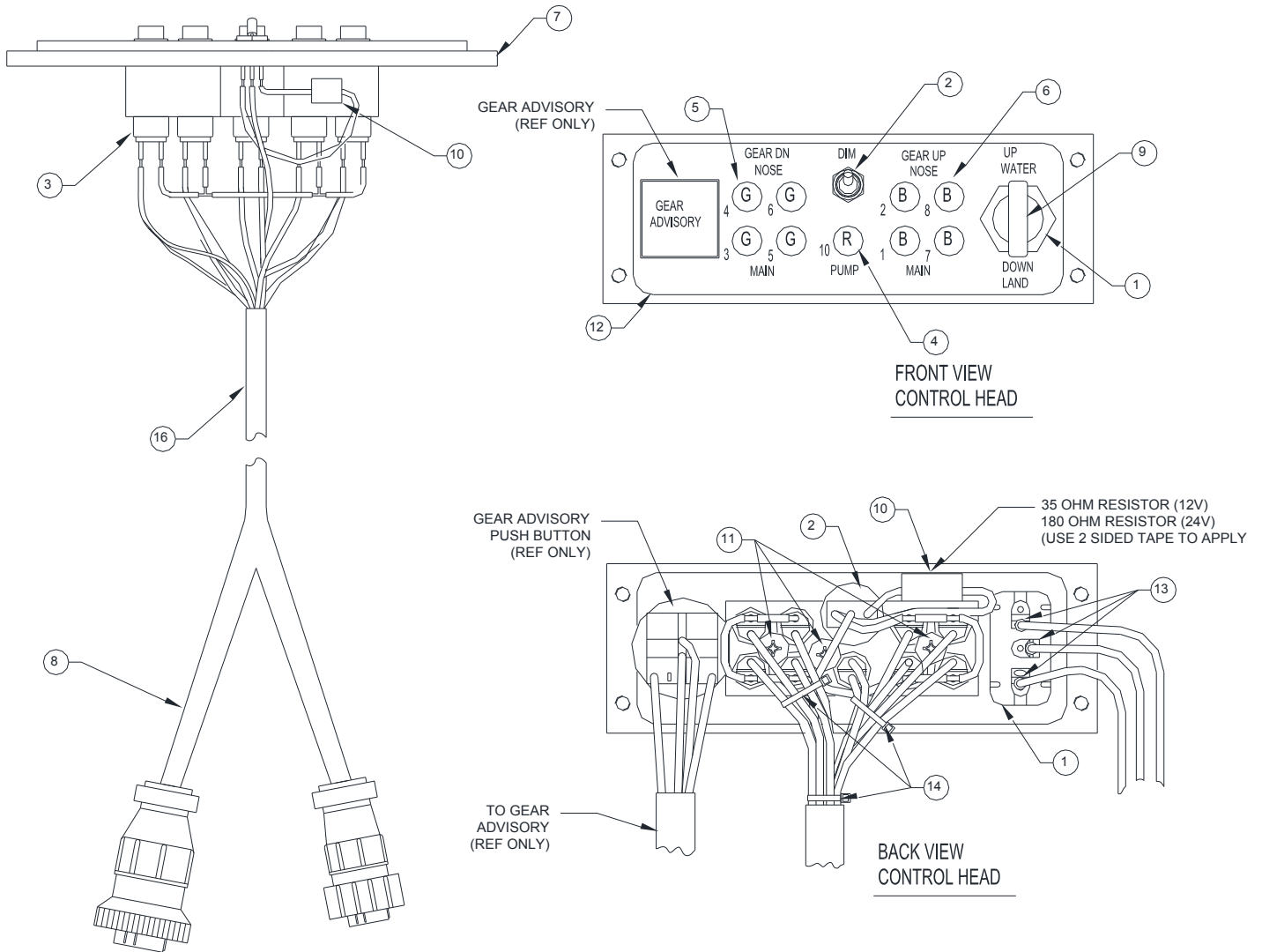

GEAR CONTROL (RECTANGLE)  
FIGURE 31

WIPLINE MODEL 3450 FLOAT PARTS MANUAL

GEAR CONTROL (RECTANGLE), FIGURE 31

<u>REF NO.</u>	<u>NO.</u>	<u>REQ.</u>	<u>PART DESCRIPTION</u>	<u>PART NO.</u>
	1		GEAR SELECTOR ASSY. ROUND (12V)	21A11000-009
	1		GEAR SELECTOR ASSY. ROUND (24V)	21A11000-019
1	1		SWITCH	8857K44
2	1		TOGGLE SWITCH, SPDT, ON-ON	A101SYCB
3	9		SOCKET	515-0012
4	1		INDICATOR LAMP, 14V, RED	507-3914-1431-600
	1		INDICATOR LAMP, 28V, RED	507-3918-1431-600
5	4		INDICATOR LAMP, 14V, GREEN	507-3914-1432-600
	4		INDICATOR LAMP, 28V, GREEN	507-3918-1432-600
6	4		INDICATOR LAMP, 14V, BLUE	507-3914-1434-600
	4		INDICATOR LAMP, 28V, BLUE	507-3918-1434-600
7	1		BLOCK, GEAR CONTROL	21A11179-001
8	1		HARNESS ASSEMBLY, GEAR SELECTOR	4A11000-008
9	1		GEAR SWITCH KNOB	21A11259-003
10	1		RESISTOR, 14V, DALE RH5 5W	RH-5-35
	1		RESISTOR, 28V, DALE RH5 5W	RH-5-180
11	3		SCREW, TRUSS HEAD, 6-32	AN526-632R8
12	1		PLACARD, ROUND2100 GEAR SELECTOR	10B3-6202
13	3		RING CONNECTOR, #6, 20 AWG, RED	R-3
14	3		CABLE TIE	PLT1M-M
15	16"		SHRINK WRAP, 3/16, WHITE	HIXR-3/16
16	3"		HEAT SHRINK TUBING	HS105-1/2-0
17	6"		WIRE, 20AWG, WHITE	22759-16-20-9



WIPLINE MODEL 3450 FLOAT PARTS MANUAL

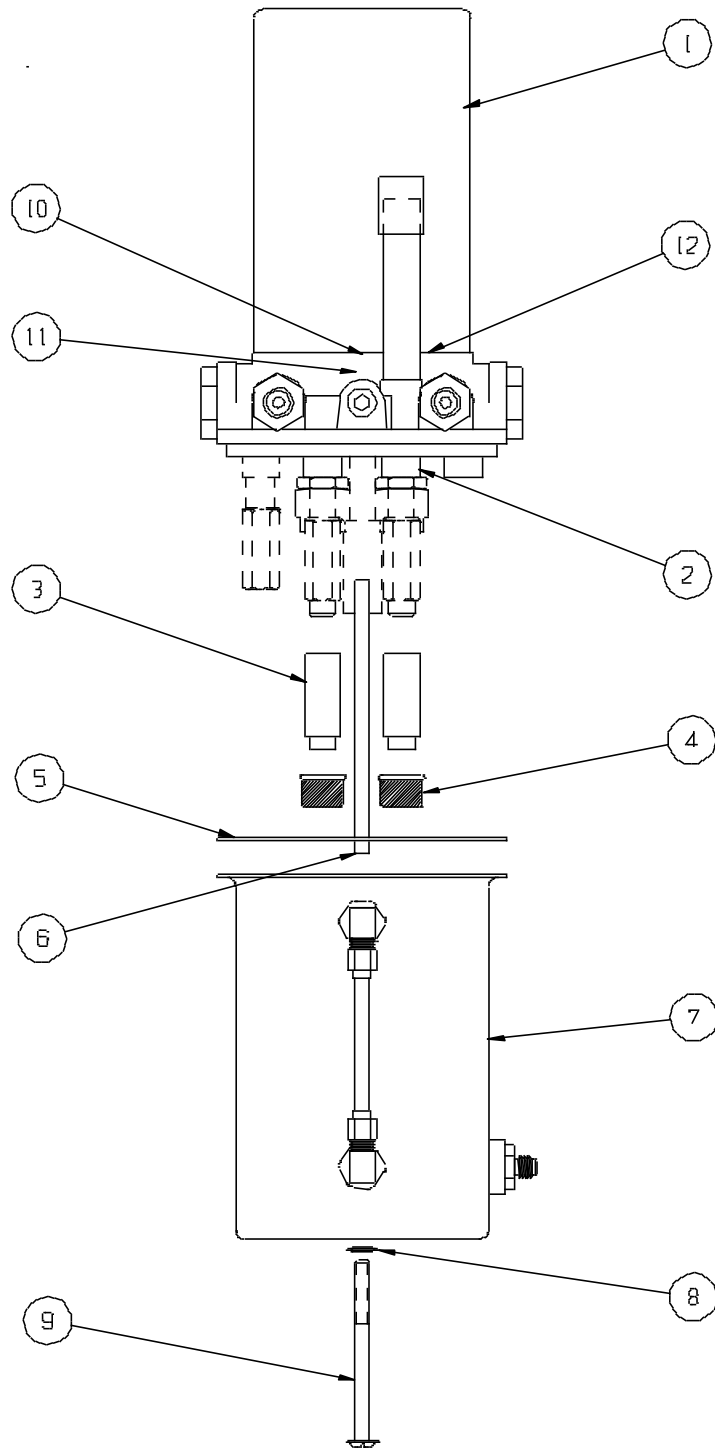

HYDRAULIC PUMP  
FIGURE 32

WIPLINE MODEL 3450 FLOAT PARTS MANUAL

HYDRAULIC PUMP, FIGURE 32

<u>REF NO.</u>	<u>NO.</u>	<u>PART DESCRIPTION</u>	<u>PART NO.</u>
1	1	HYDRAULIC PUMP ASS'Y (12V)	21A09000-215
		HYDRAULIC PUMP ASS'Y (24V)	21A09000-282
		MOTOR (12V)	640661
		MOTOR (24V)	641131
2	1	BASIC PUMP	634873
3	2	TUBE EXTENSIONS	362136
4	2	FILTER	410521
5	1	SEAL RESERVIOR	410578
6	1	RETURN TUBE	365047
7	1	RESERVIOR – GAUGE ASS'Y	775260
8	1	SEAL THREAD	415067
9	1	SCREW – RESERVIOR ATTACH	409715
10	1	COUPLING – MOTOR TO PUMP	361183
11	1	SEAL – PUMP SHAFT	410512
12	1	“O” RING MOTOR TO BASE	405673