

DATE: June 1, 2000

SERVICE KIT: #27

SUBJECT: Conversion Kit for Replacement of McCauley Main Wheels and Brakes on Wipline Floats

MODEL: Wipline Model 6000, 6100, and 8000 Floats

<u>Item</u>	<u>Quantity</u>	<u>Part No.</u>	<u>Description</u>
1.	1	199-243 (4 Wheels/4 Brakes)	Parker Hannifin Conversion Kit
	4	40-418	Main Wheel Assembly (6.00-6)
	4	30-241	Brake Assembly
			Brake Lining Conditioning Procedure

Note: This service kit will convert 1 aircraft (2 floats) from existing McCauley wheels and brakes to Parker sand cast aluminum wheels and brakes. Intermixing of McCauley and Parker equipment is not recommended.

INSTALLATION INSTRUCTIONS:

1. Refer to your applicable Wipaire Service Manual for jacking procedures before wheel & brake removal and installation instructions.
2. Existing tires and tubes may be used on new wheels provided they are serviceable.
3. Refer to Parker Hannifin Component Maintenance Manual Number AWBCMM0001-3/USA for proper wheel and brake repair and service instructions. Contact Parker Hannifin Technical Service Hotline @ 1-800-272-5464 to procure this manual.
4. Refer to pages 2 and 3 for illustrated parts breakdown of above wheel and brake assembly and fastener torque values.
5. Upon completion of installation, make appropriate entries to aircraft maintenance logs denoting installation of kit.
6. Prior to returning aircraft to service, condition brake linings in accordance to Parker Hannifin brake lining conditioning procedure.

WEIGHT AND BALANCE:

The shipset weight for 4 McCauley wheels and brakes is 47.78 lbs. The weight of 2 p/n 40-418 wheel assemblies and 4 p/n 30-241 brake assemblies is 54.12 lbs. Therefore, there is a 6.64 lb. weight increase utilizing the p/n 199-243 kit.

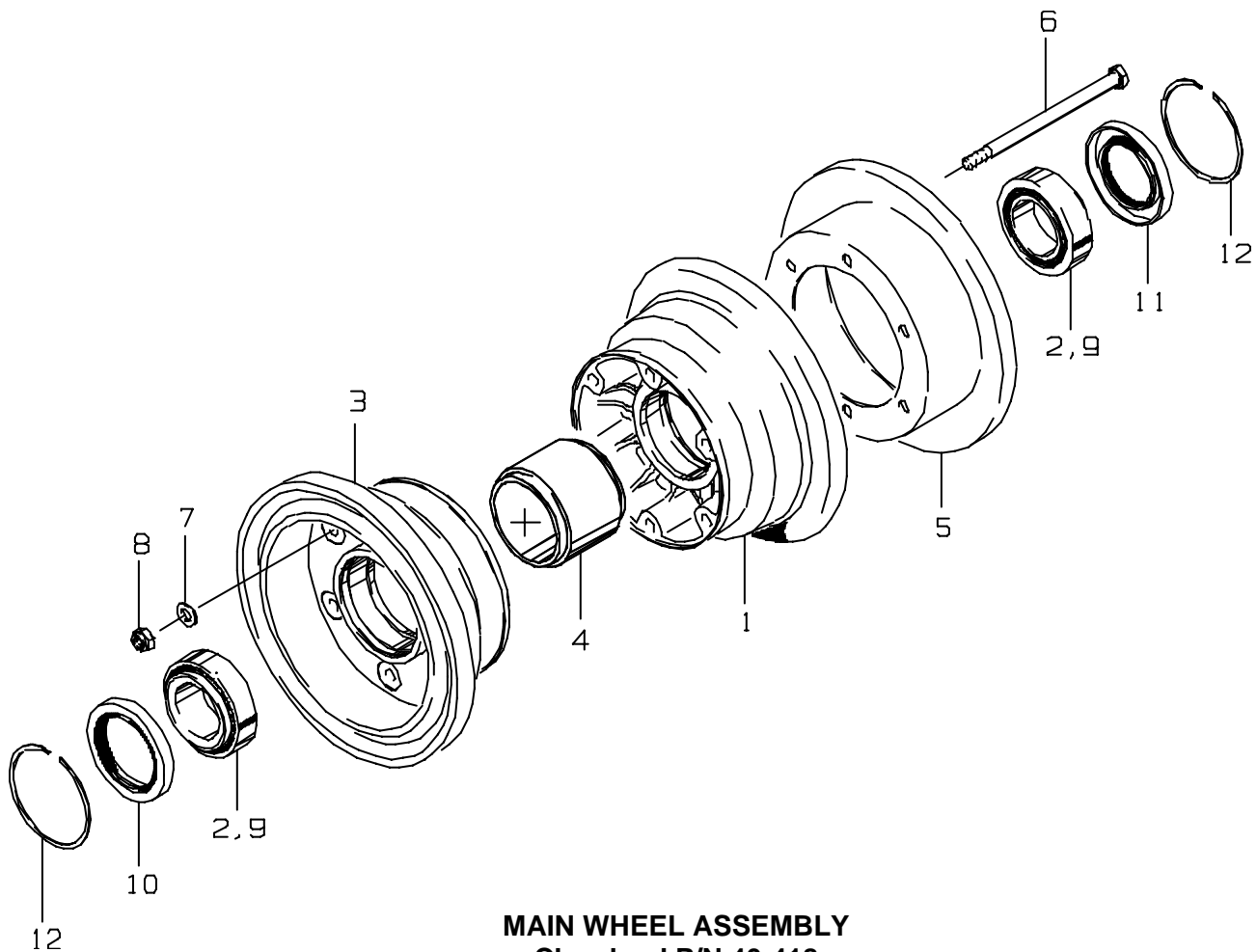

MAIN WHEEL ASSEMBLY
Cleveland P/N 40-418

ITEM	PART NUMBER	DESCRIPTION	QTY PER ASS'Y
* 1	161-19900	Subassembly, Wheel Half, Inner	1
2	214-01100	Cup, Bearing	1
* 3	162-19900	Subassembly, Wheel Half, Outer	1
2	214-01100	Cup- Bearing	1
4	067-14700	Spacer, Grease Dam	1
5	164-24500	Disc, Brake	1
** 6	103-20400	Bolt (AN5-35A)	6
7	095-10500	Washer (AN960-516)	6
** 8	094-10400	Nut (MS21044-N5)	6
9	214-01200	Cone, Bearing	2
10	154-08300	Seal, Grease	1
11	154-08200	Seal, Grease	1
12	155-14300	Ring, Snap	2
- 13	166-20000	Nameplate "Warning"	1
- 14	166-19700	Nameplate	1

- Item not illustrated.

* Subassembly includes wheel half with bearing cup installed.

** Dry torque fasteners to 150 in-lbs. during tire installation.
 Grease bearings with BG Products #605 HCF Grease.

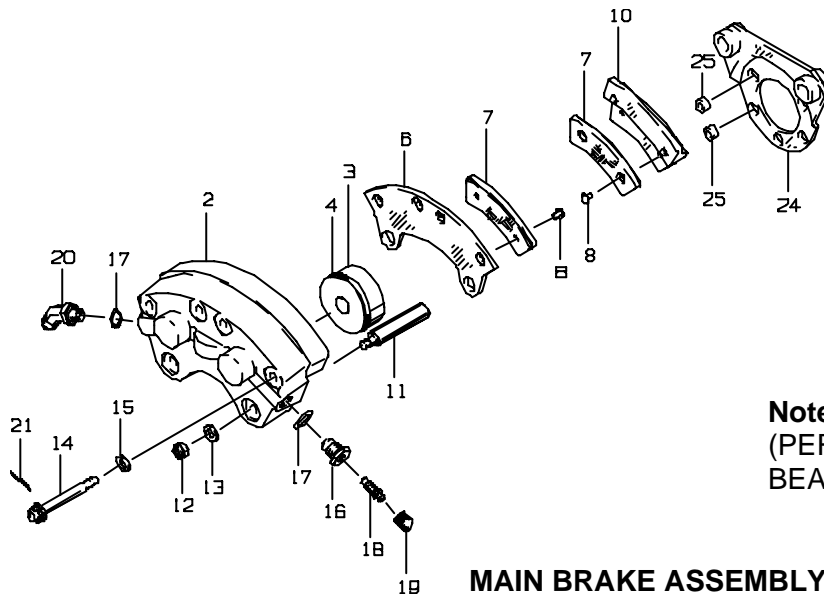

Note: APPLY ANTISEIZE COMPOUND (PER MIL-T-5544) TO THREADS AND BEARING SURFACES.

**MAIN BRAKE ASSEMBLY
Cleveland P/N 30-241**

ITEM	PART NUMBER	DESCRIPTION	QTY PER ASS'Y	TORQUE VALUE
*- 1	091-21600	Subassembly, Cylinder	1	
2	061-16600	Cylinder	1	
3	062-10700	Piston	2	
4	101-02700	O-Ring (MS28775-222)	1	
- 5	073-04200	Subassembly, Plate, Pressure	1	
6	063-01100	Plate, Pressure	1	
7	066-10500	Lining	2	
8	105-00200	Rivet	4	
- 9	074-02900	Subassembly, Plate, Back	2	
10	064-01500	Plate, Back	2	
7	066-10500	Lining	2	
8	105-00200	Rivet	4	
11	069-03100	Bolt, Anchor	2	
12	094-10300	Nut (MS21044-N4)	2	Dry Torque 60 to 95 in-lbs.
13	095-10400	Washer (AN960-416)	2	
** 14	103-85500	Bolt (MS21250H04026)	4	Lubtork to 90 in-lbs.
15	095-14300	Washer (MS20002C4)	4	
16	081-00200	Seat, Bleeder	1	Dry Torque 65 to 70 in-lbs.
17	101-00700	O-Ring (MS28775-012)	1	
18	079-00300	Screw, Bleeder	1	Torque "snug"
19	183-00100	Cap, Bleeder	1	
20	104-04700	Fitting	1	Dry torque 65 to 70 in-lbs.
21	MS20995-C32	Lockwire	AR	
- 22	166-20100	Nameplate	1	
- 23	215-00800	Cap, Shipping	1	
24	075-20700	Assembly, Plate, Torque	1	
25	145-01000	Bushing	2	

AR...As Required (for bulk items).

- Item not illustrated.

* Subassembly includes all items except 24 and 25.

** Lockwire bolt heads (item 14) together per MS33540 after torquing.