



WIPLINE FLOATS • SKIS • MODIFICATIONS • AIRCRAFT SALES
AVIONICS • INTERIOR • MAINTENANCE • PAINT REFINISHING



**SERVICE MANUAL AND INSTRUCTIONS FOR
CONTINUED AIRWORTHINESS
WIPLINE MODEL 10000 AMPHIBIOUS FLOATS
AT-802A FIRE BOSS CONVERSION**

Revision AB

1700 Henry Avenue — Fleming Field South St. Paul, MN 55075
direct: 651.209.7191 • fax: 651.294.0050 • www.firebossllc.com



THIS PAGE INTENTIONALLY LEFT BLANK

LOG OF REVISIONS

Rev	Pages	Description	Date
A-L	All	For previous revision changes, reference Service Manual for 10000 Amphibian Floats on Air Tractor AT-802A - Fire Boss Conversion Revision L part number 1002545.	5/26/2015
M	3, 17, 83, 89	Added Dow Corning DC4, Corrosion X, and Mobil Aviation Grease SHC 100 to approved product list. Modified torque limit section.	12/4/2015
N	All	Updated headers, footers, and document formatting. Added scoop probe damage and weld crack check to 100-hour inspection interval. Added Main Landing Gear Lower Attach Bolt inspection to annual inspection interval. Added "inside hydraulic reservoir" after hydraulic fluid screen in inspection checklist and changed to annual interval. Added "replace spin on filter" in inspection checklist. "Metering Pin" changed to "Metering Tube" in Shock Strut Servicing Section. Added overgross landing inspection checklist and added overgross landing to "Hard Landing Damage Investigation" section. Added spin on filter bypass flag inspection.	6/6/2017
P	4	Added reference for Structural Repair Manual part number 1008274 in introduction.	5/1/2019
R	7, 18, 51, 88	Removed mention of drawing for lifting beam. Changed metering tube dimension. Adjusted steering and balance cable tension. Updated torque limit chart.	7/12/2019
T	18, 88, 90	Added note about STA-Lube. Added STA-Lube to Brake Caliper Grease. In Nose and Main Gear Tracks section, changed Teflon coating spray to grease.	1/23/2020
U	19, 100, 103-105, 108-111, 114	Updated Nose Box Track tolerance from .070" to .050". Added info about hardware replacement. Added Section 14.2 checklist for hardware retorque and replacement. Updated Inspection Time Checklist with details about Aft Pylon Drag Strut Bolt, Nose Gear Spring, Service Letter 170, and Nose Gear Tracks. Added details about Nose Gear Springs in Inspection Checklist. Added Figure 15.1.	6/30/2020
V	11-14, 18, 88, 97	Added Sections 1.3 through 1.7. Added information about corrosion limits. Removed content in Chapter 13 and replaced with note about SRM. Removed Comet Industries 6P-730A. Added item 21 in Retorque and Replacement Checklist.	2/3/2021
Y	48-50, 53-54, 92	Updated Section 4.2 and Section 4.4. Updated Figure 4.2A. Added Figure 4.2B and 4.2C. Added Section 4.7 Asymmetric Scoop Reporting and instructions. Added Aeroshell 64 as an approved Wheel Bearing grease for nose pivot block only.	9/22/2021
AA	7	Added note about 1011959 in Introduction for Commercial Parts List.	5/10/2022
AB	15, 24-25, 103	Added note about Baldwin filter in section 1.8 and the Inspection Checklist. Updated instructions in Shock Strut Servicing section. Updated Shock Strut Servicing instruction step 5 and removed note.	11/3/2022

View most current revision of this ICA at www.wipaire.com.

THIS PAGE INTENTIONALLY LEFT BLANK

TABLE OF CONTENTS

INTRODUCTION.....	7
CHAPTER 1 GENERAL INFORMATION	9
CHAPTER 2 MAIN GEAR AND NOSE GEAR OPERATION, REMOVAL AND SERVICE	21
CHAPTER 3 HYDRAULIC PUMP SYSTEM, DISASSEMBLY AND SERVICE	41
CHAPTER 4 SCOOP SYSTEM OPERATION, REMOVAL, AND SERVICE.....	47
CHAPTER 5 FOAM DELIVERY SYSTEM OPERATION, REMOVAL AND SERVICE.....	55
CHAPTER 6 FLOAT BILGE SYSTEM OPERATION, REMOVAL, AND SERVICE	59
CHAPTER 7 VENT AND OVERFILL PROTECTION SYSTEM.....	61
CHAPTER 8 FLOAT STEERING AND RETRACT SYSTEM.....	63
CHAPTER 9 ANGLE OF ATTACK SYSTEM.....	67
CHAPTER 10 AIRCRAFT WING AND CONTROL SURFACE MODIFICATIONS	69
CHAPTER 11 AUXILIARY INSTRUMENT PANEL	71
CHAPTER 12 ELECTRICAL	75
CHAPTER 13 REPAIRING FLOAT HULL SHEET METAL, BULKHEADS AND OTHER AREAS.....	89
CHAPTER 14 CONTINUED AIRWORTHINESS	91
CHAPTER 15 INSPECTION CHECKLISTS	101
CHAPTER 16 WEIGHT AND BALANCE	109

LIST OF FIGURES

FIGURE 1.1 JACK CRADLE RECOMMENDED MODIFICATION	12
FIGURE 1.2 JACKING LOCATION.....	12
FIGURE 1.3 FLOAT SECURING LOCATIONS.....	13
FIGURE 1.4 FLOAT SECURING LOCATIONS OVERVIEW	14
FIGURE 2.1 SCHEMATIC - HYDRAULIC SYSTEM	31
FIGURE 2.2 SCHEMATIC - ELECTRICAL SYSTEM	32
FIGURE 2.3 LAYOUT – MAIN GEAR	33
FIGURE 2.4 CARRIAGE ASSEMBLY – MAIN GEAR	34
FIGURE 2.5 ASSEMBLY – MAIN GEAR SHOCK STRUT	35
FIGURE 2.6 ASSEMBLY – MAIN GEAR ASSEMBLY	36
FIGURE 2.7 ASSEMBLY – MAIN GEAR DRAG LINK.....	37
FIGURE 2.8 ASSEMBLY – MAIN GEAR WHEEL AND BRAKE	38
FIGURE 2.9 ASSEMBLY – NOSE GEAR BOX AND RETRACTION	39
FIGURE 2.10 ASSEMBLY – NOSE GEAR LOWER END	40
FIGURE 4.1A ASSEMBLY – SCOOPING SYSTEM - COMPLETE	51
FIGURE 4.1B ASSEMBLY – SCOOPING SYSTEM.....	52
FIGURE 4.2A ASSEMBLY – CYLINDER PROBE JACK.....	53
FIGURE 4.2B – PROBE UP POSITION ADJUSTMENT.....	54
FIGURE 4.2C – PROBE DOWN POSITION ADJUSTMENT	54
FIGURE 5.1 SCHEMATIC – PLUMBING – FOAM SYSTEM.....	57
FIGURE 8.1 WATER RUDDER STEERING AND RETRACTION SYSTEM	65
FIGURE 11.1 INSTRUMENT PANEL.....	72
FIGURE 11.2 INSTRUMENT PANEL (CIRCUIT BREAKER).....	73
FIGURE 12.1 SCHEMATIC – AUXILIARY INSTRUMENT PANEL.....	77
FIGURE 12.2 SCHEMATIC – CIRCUIT BREAKER PANEL.....	78
FIGURE 12.3 SCHEMATIC – INSTALLATION – ANGLE OF ATTACK	79
FIGURE 12.4 AOA FLAP CALIBRATION READINGS	80
FIGURE 12.5 SCHEMATIC – INSTALLATION – FOAM TANKS/PUMPS	81
FIGURE 12.6 SCHEMATIC – INSTALLATION – BILGE PUMPS	82
FIGURE 12.7 SCHEMATIC – INSTALLATION – SCOOP/FILL SYSTEM	83
FIGURE 12.8 SCHEMATIC – INSTALLATION – PROBE POSITION	84
FIGURE 12.9 SCHEMATIC – INSTALLATION – PDR 60 AUDIO	85
FIGURE 12.10 SCHEMATIC – INSTALLATION – ITT / EXCESS POWER LIGHT	86
FIGURE 12.11 SCHEMATIC – INSTALLATION – WATER IN FLOAT SENSORS	87
FIGURE 15.1 EXAMPLE NOSE SPRING CRACK MEASUREMENTS (NOT TO SCALE).....	108

INTRODUCTION

This manual describes the general servicing and maintenance for the Model 10000 float, on the Air Tractor AT-802A aircraft. Includes hull, landing gear, and scooping systems. For services and repairs not covered by this manual contact Wipaire Customer Service.

When performing standard repairs for Wipline Aluminum Floats, please refer to the “Structural Repair Manual For Wipline Aluminum Floats” part number 1008274. It is available free of charge online at www.wipaire.com.

The service products referred to throughout this manual are described by their trade name and may be purchased from the Wipaire Parts Department.

Reference Wipaire document number 1011959 for a list of commercial parts applicable to STC SA01795CH.

To contact Wipaire for technical support or parts sales, call, write or email:

Wipaire, Inc.
Customer Service
1700 Henry Avenue – Fleming Field
South St. Paul, MN 55075
Phone: (651) 306-0459
Fax: (651) 306-0666
Website: www.wipaire.com
Email: CustomerService@wipaire.com

THIS PAGE INTENTIONALLY LEFT BLANK

CHAPTER 1 GENERAL INFORMATION

CONTENTS

1.1 AIRPLANE	10
1.2 FLOATS.....	10
1.3 TOWING.....	11
1.4 HOISTING.....	11
1.5 LEVELING	12
1.6 JACKING PROCEDURES.....	12
1.7 JACK REMOVAL	14
1.8 AMPHIBIAN LANDING GEAR SYSTEM.....	14
1.8.1 LANDING GEAR HANDLE	15
1.8.2 INDICATOR LIGHTS.....	15
1.8.3 LANDING GEAR OPERATION	15
1.8.4 EMERGENCY PUMP HANDLE.....	16
1.9 SCOOP SYSTEM.....	16
1.10 FOAM SYSTEM.....	16
1.11 VENT AND OVERFLOW PROTECTION.....	17
1.12 HARD AND OVERGROSS LANDING AND DAMAGE INVESTIGATION.....	17
1.13 CLEANING.....	18
1.14 CORROSION.....	18
1.15 MEANS FOR LEVELING	19

CHAPTER 1 - GENERAL

1.1 AIRPLANE

The airframe of the Fire Boss is adapted from the Air Tractor AT-802A agricultural airplane. It is an all-metal, low cantilever wing design. It is powered by a Pratt and Whitney PT6A-67AG turboprop engine of 1350 SHP or PT6A-67F of 1600 SHP. The airframe is detailed in Air Tractor publications.

To create this fire suppression version of the airplane, a number of changes to the landplane were incorporated:

1. Amphibious floats with hydraulically actuated water scoops are installed.
2. The Air Tractor Fire Retardant Delivery System (FRDS) is utilized.
3. The Air Tractor foam system and controls are utilized.
4. Additional foam tanks in the floats supplement the standard firewall tank.
5. Changes to the hopper venting system are incorporated.
6. A new upper instrument panel is added to contain some of the scoop related and system controls and indicators.
7. A bilge pumping system and a water in floats warning system are incorporated.

These changes will be briefly discussed in the following paragraphs.

1.2 FLOATS

The model 10000 amphibious float is an all aluminum constructed float with (12) watertight compartments of approximately 10,000 pounds buoyancy. As a part of the float installation, the following additional changes are made to the landplane:

1. The hydraulic landing gear retraction system components and cockpit controls are added.
2. The cockpit landing gear controls and emergency hand pump and system are added.
3. The float water rudder retraction system and cockpit controls are added. The water rudders are locked center when retracted for improved directional stability.
4. A ventral fin is added for improved directional stability.
5. Two auxiliary finlets are added to each side of the horizontal stabilizer for improved directional stability. Four total per aircraft.
6. The vertical fin is sealed to the fuselage/stabilizer top for improved directional stability.
7. The open fuselage structure near the landplane tail-wheel mount is faired over for improved directional stability.

8. Pump-out cups on float top deck are placed between each float watertight compartment to pump out any water in floats before flight.
9. Vortex generators are added to the wing upper surface leading edges for improved longitudinal controllability.
10. Vortex generators are added to the horizontal stabilizer upper surface leading edges for improved longitudinal controllability and stall speed reduction.
11. The elevator trim/servo tabs incorporate a 1-inch chord extension for improved longitudinal controllability.
12. Access to the float interior is accomplished by removing covers on the top deck and six covers inside the wheel well. When necessary, water inside the float hulls may be removed through pump-out cups located on the outboard edge of each float top skin.

1.3 TOWING

When towing the amphibian aircraft, 2 lugs are provided on the lower forward side of the nose spring.

On land, a rigid "V" frame can be fabricated to attach to these lugs for towing the aircraft with a tractor. Lake & Air Training and Pilot Shop has this tow bar available for purchase.



On water, a rope bridle arrangement can be used to tow the aircraft from the lugs described above.

1.4 HOISTING

Hoisting the aircraft can be performed using a lifting rig that attaches to the aircraft with lifting rings that are installed at the wing attach points. If the lifting rings are not installed, reference applicable aircraft maintenance/service manual for additional hoisting specifications. Lake & Air Training and Pilot Shop has this hoisting rig available for purchase. Contact Wipaire Customer Service for additional guidance in removal or installation of floats.

CAUTION!

Make sure nothing is under or above the airplane or floats when hoisting the aircraft

1. Raise aircraft high enough to place float cradle under floats as shown in Figure 1.4.
2. Lower aircraft onto float cradle as shown in Figure 1.4.
3. Place fore and aft supports as shown in Figure 1.3 and Figure 1.4.

1.5 LEVELING

See applicable aircraft maintenance/service manual.

1.6 JACKING PROCEDURES

CAUTION!

Make sure nothing is under or above the airplane or floats when jacking the aircraft.

1. Turn off fuel.
2. Place weighted bags above the nose gear (approximately 100 lbs. on each float to start, more may be added as needed).
3. Position 1 person at each fore and aft of each float, and 3 people at the jacking location of one float.
4. Modify jack saddle of a 3 ton minimum jack by welding as shown in Figure 1.1.

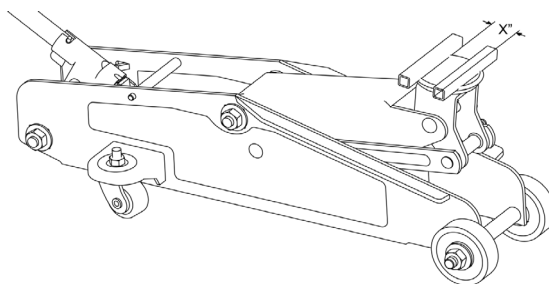

(X = WIDTH OF CRADLE)

FIGURE 1.1 JACK CRADLE RECOMMENDED MODIFICATION

NOTE: This is not required and Wipaire does not have the parts for modification. It is recommended a similar modification be performed to the jack saddle to prevent the slippage of the cradle.

1. Center cradle on saddle and position so cradle is as far aft on the main keel as possible without interfering with main gear as it decompresses as shown in Figure 1.2.

NOTE: If desired to prevent possible cosmetic damage to float, use material to separate cradle and float.



FIGURE 1.2 JACKING LOCATION

SERVICE MANUAL & ICA
10000 AMPHIBIAN FLOATS ON AIR TRACTOR AT-802A

1. Jack one side at a time, taking care to check the balance of the aircraft and adding more weight to the front if needed.
2. Two people, both outboard, lift the fore and aft cradle stands up to the cradle as a 3rd person release the pressure slowly, allowing the cradle and stands to gently contact the ground.
3. Repeat previous procedure to the other float.

NOTE: A smaller jack may be needed to slightly lift the float into a high enough position for the main jack.

4. Secure floats with fore and aft supports as shown in Figure 1.3 and Figure 1.4.



FIGURE 1.3 FLOAT SECURING LOCATIONS



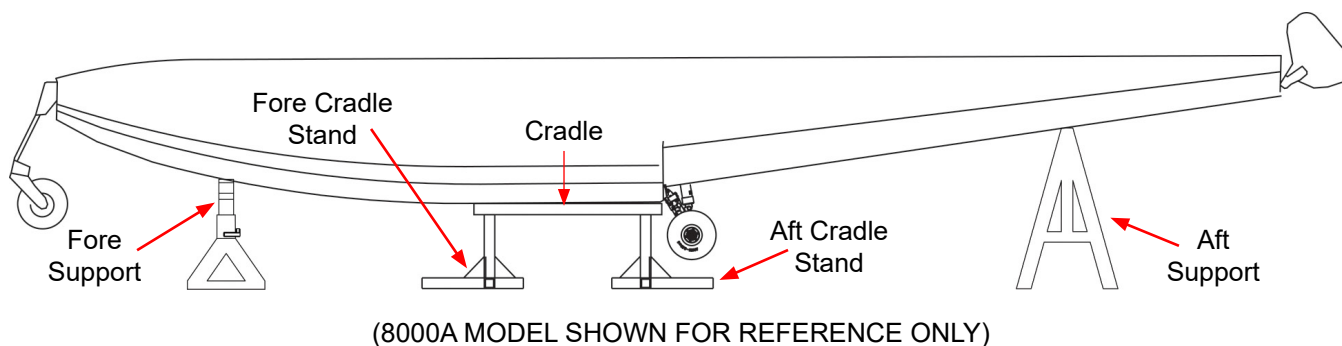

FIGURE 1.4 FLOAT SECURING LOCATIONS OVERVIEW

1.7 JACK REMOVAL

Make sure nothing is under or above the airplane or floats when removing the jacks from the aircraft

1. Turn off fuel.
2. Verify landing gear is in the down and locked position.
3. Verify weighted bags are still located above the nose gear.
4. Position 1 person at each fore and aft of each float, and 1 person at the jacking location of one float.
5. Remove all fore and aft supports as shown in Figure 1.3 and Figure 1.4.
6. Using modified jack saddle as shown in Figure 1.1, center jack saddle in center of cradle on 1 of the floats,
7. Lift aircraft to clear fore and aft cradle stands and remove fore and aft cradle stands of lifted float.
8. Slowly lower float to the ground, remove jack from under float, and remove cradle from jack saddle.
9. Repeat previous procedure to the other float.
10. Remove weighted bags from floats.

1.8 AMPHIBIAN LANDING GEAR SYSTEM

The landing gear incorporated within the amphibious floats on this airplane is retractable, quadricycle type with two swiveling nose (or bow) wheels and four (4) (two (2) sets of dual) main wheels. Air-oil shock struts on the two main landing gear assemblies provide shock absorption.

The main landing gear has dual 8:50 x 10 8-ply tires and the nose landing gear has one 6:00 x 6 8-ply tire. The gear system is hydraulically actuated and driven by two hydraulic pumps. Brakes are hydraulic and have a caliper on each main wheel for a total of four brakes.

Steering on land is accomplished by differential braking. The nose wheels are full casting.

Landing gear extension and retraction is accomplished by two (2) electrically-driven hydraulic pumps and four (4) hydraulic actuators (one (1) for each gear). The hydraulic pumps are located in fuselage aft of cockpit and the hydraulic actuators are located adjacent to each gear. Hydraulic system fluid level should be checked periodically by viewing the sight glass for fluid level in the upper one-third of the range. If fluid is low, fill with MIL-H-5606 or equivalent. Filter screens are installed on each pickup tube inside of hydraulic reservoirs and there are also 3 external 10 micron filters as well. Clean filter screens and elements every 100 hours.

Per Service Letter 103, a Spin-on Type filter assembly with a Baldwin Filter has been incorporated to facilitate additional filtering of the hydraulic system. Replace Baldwin filter if pop out gage (if equipped) has been released indicating bypass has been activated due to clogged filter or at time of annual inspection.

Landing gear operation is initiated by movement of the landing gear handle. When the handle is repositioned, hydraulic pressure in the system will drop and pressure switches will automatically turn on the hydraulic pump motors to maintain operating pressure in the system. When the gear cycle is completed, the pump will automatically shut off. If the pressure in the system drops to a preset value, the pressure switches turn the pump motors back on and build up the pressure to the limit again. Eight (8) position-indicator lights four (4) gear UP and four (4) gear DOWN are provided to show landing gear position. Two (2) additional indicator lights show when the landing gear pump motors are operating.

1.8.1 LANDING GEAR HANDLE

The landing gear handle controls a hydraulic selector valve within the control unit on the left-hand side of cockpit by fuel shut-off handle and has two (2) positions (UP and DOWN LAND) which give a mechanical indication of the gear position selected. From either position, the handle must be pulled out to clear a detent before it can be repositioned.

1.8.2 INDICATOR LIGHTS

Ten (10) indicator lights are mounted on the landing gear control unit adjacent to the landing gear handle. Four (4) blue indicator lights, labeled NOSE and MAIN (left-hand lights for the left float and right-hand lights for the right float), show by their illumination that the landing gear is up and locked. The four (4) green indicator lights, labeled NOSE and MAIN (left-hand lights for the left float and right-hand lights for the right float), are illuminated when the landing gear is down and locked. Neither set of lights is illuminated when the landing gear is in transit. Two (2) red indicator lights, labeled PUMP ON 1 and 2 illuminate when current is supplied to the landing gear motors.

If the motors continue running during flight or on and off repeatedly, the motors should be shut off by pulling AMPHIBIAN PUMP 1 AND AMPHIBIAN PUMP 2 circuit breakers. Continual running of the motors can result in premature motor failure. Prior to landing, the circuit breakers should be pushed in to reactivate the circuits. Troubleshoot hydraulic problem per section 3.1.

1.8.3 LANDING GEAR OPERATION

To retract or extend the landing gear, pull out on the landing gear handle and move it to the desired position. When the handle is positioned, pressure on the hydraulic system reduces to where the hydraulic motors automatically turn on.

The motors power the hydraulic pumps and actuate the gear actuator for each gear. During operation of the landing gear motors the PUMP ON 1 and 2 indicator lights are illuminated. When the gear cycle is completed, pressure builds up in the hydraulic system and automatically shuts off the hydraulic motors. Each gear operates independently of the other, and therefore, the position lights illuminate at various times.

1.8.4 EMERGENCY PUMP HANDLE

An emergency hand pump is located on the floor to the left side of the seat for use in the event the normal hydraulic system fails. This hand pump may be used to retract or extend the land gear. Prior to utilizing the emergency hand pump, pull the AMPHIB PUMP 1 and 2 circuit breakers to deactivate the electric hydraulic pumps. Select UP and DOWN using the normal landing gear selector handle. Pump the attached handle back and forth (approximately 400 cycles). When a gear reaches the selected position, its indicator light will illuminate. After all four (4) gears are in the selected position there is a noted increase in resistance of hand pump operation.

1.9 SCOOP SYSTEM

The Wipaire 802 Fire Boss has two water scoops, one in each float. The scoops are three inches in diameter and are hydraulically operated by the 1000 psi float hydraulic system. The hydraulic system has an accumulator to enhance the speed of scoop deployment and retraction. The scoops complete down or up cycle in approximately one second. A trigger switch located on the front of the control stick grip controls the scoops. Pulling in the top of the trigger switch puts the scoops down. Releasing the trigger switch puts the scoops back up (pulling on the bottom of the trigger switch operates the smoke system; see Air Tractor Flight Manual).

The scoop system master switch is located on the glare shield panel and has three positions, auto, off, and manual. When manual is selected, the scoops move to the down position and remain there as long as the trigger switch is depressed; when the trigger switch is released, the probes move back to the up/stowed position.

CAUTION!!

In the manual position, it is possible to overflow the hopper.

When auto is selected, the pilot may select how many gallons he wants to scoop by rotating the fill level selector knob located to the right side of the hopper quantity and fill level readout window (hopper quantity is on the top reading and the selected fill level is on the bottom).

When the quantity reads approximately 255 gallons the hopper empty (the scale starts at that number) with auto selected, the scoops will go down when the rocker switch is depressed and move back up automatically when the quantity selected is reached (with the rocker switch still depressed). If the rocker switch is released before the quantity is reached, the scoops will move back up.

If the pilot wants to abort the scoop operation once it is initiated, simply releasing the rocker switch will put the scoops back up, such as in an emergency or other unplanned occurrence. Scoop up and scoop down lights are provided that indicate scoop position via a pressure switch that illuminates the lights. The scoop lights (2) can be tested utilizing the test switch on the left side of the glare shield panel.

1.10 FOAM SYSTEM

The Wipaire 802A Fire Boss foam system consists of three individual tanks. The original 18-gallon firewall tank is supplemented by an additional 30 U.S. gallon tank in each float (at sta +1) of which approximately 28 U.S. gallons is usable in the automatic mode. In the manual mode all 30 gallons are usable. A total of approximately 74 U. S. gallons can be delivered to the hopper (in the automatic mode) utilizing the foam control panel located on the left side of the cockpit just below the fire gate computer. In the manual mode, a total of 78 gallons can be delivered to the hopper. The float tanks are optional and one or both can be removed depending on the type of operation. (Tank and floor 50 lbs at +1.0 each float)

To use fluid stored in the float tanks, it is necessary to pump fluid from the float tank to the fuselage firewall tank. This transfer can be accomplished manually or automatically by selecting the appropriate position with the left and right foam control switches located on the glare shield panel. When manual "on" is selected, fluid will be pumped via the electric pump located on the top of the tank to the firewall tank.

The pump does not shut off when the tank is full. In the event of an over flow, fluid would come out of the firewall tank vent fitting located just aft of the front left float strut.

When auto is selected, the float tank transfer pump will come on at approximately 7 gallons of fluid remaining in the fuselage tank. It will shut off automatically when the fuselage tank is approximately 2/3 full or whenever the selected float tank has about 2 gallons remaining.

The left and right transfer systems can be used individually or simultaneously as desired. Whenever a foam transfer pump is operating, the appropriate green Pump On light will illuminate (manual or auto). The Pump On lights can be tested utilizing the test switch on the left side of the glare shield panel.

1.11 VENT AND OVERFLOW PROTECTION

The original 802-hopper vent/door has been modified to allow for a greater venting volume during scooping operations. The original 3-inch Air Tractor vent located on the aft right side of the fire gate is supplemented with the addition of a 5-inch vent that exits at the right aft side of the rear fire gate fairing. In the event of an overflow during scoop operations, a spring loaded relief valve door is located directly aft of the main drop vent door. Water will exit the hopper to the right and forward of the cockpit windshield. The pilot can see ahead out of the left side of the windshield during an overflow condition.

The door spring needs approximately 40 pounds of pressure to open. To check this, use a hand held spring type scale. Locate scale to the center of door on outside edge.

NOTE: Before opening the main vent door for access, the door bracing turnbuckles (located inside the hopper just below the vent door) need to be disconnected. They are accessible with the drop vent door open (1 on each side).

1.12 HARD AND OVERGROSS LANDING AND DAMAGE INVESTIGATION

After a thorough cleaning of the suspected damaged area, all structural parts should be carefully examined to determine the extent of damage. Frequently the force causing the initial damage is transmitted from one member to the next causing strains and distortions. Abnormal stresses incurred by shock or impact forces on a rib, bulkhead or similar structure may be transmitted to the extremity of the structural member, resulting in secondary damage, such as sheared or stretched rivets, elongated bolt holes or wrinkled skins or bulkheads.

Points of attachment should be examined carefully for distortion and security of fastenings in the primary and secondary damaged areas at locations beyond the local damage. A checklist in the Continuous Airworthiness chapter of this manual provides the details on areas requiring inspection when aircraft is suspected of exceeding its published landing weight.

1.13 CLEANING

The outside of the float should be kept clean by washing with soap and water. Special care should be taken to remove engine exhaust trails, waterline marks, and barnacle deposits. After saltwater operation, washing with fresh water should be done daily with special attention to hard-to-reach places such as: seams, wheel well, etc.

Alternatively, water taxiing in FRESH WATER at step-speed with the water scoops in the DOWN position and the fire gates OPEN can help to flush the entire system. This method is especially recommended as a daily cleaning for operators scooping in saltwater.

NOTE: Operators scooping saltwater are strongly cautioned – rinsing the entire aircraft & floats with fresh water inside and outside at the end of each day is critical. Failing in this cleaning will severely shorten the life of the floats.

The float interior should be flushed if saltwater enters the compartments. If the floats are being stored inside, remove inspection covers so the interior will dry out.

NOTE: The above cleaning techniques are vital for keeping corrosion to a minimum. Saltwater operations and environment are strongly linked to corrosion and must be addressed proactively.

1.14 CORROSION

Reference the Wipaire Structural Repair Manual (SRM) for allowable corrosion/material loss limits. Corrosion is a reaction that destroys metal by an electrochemical action that converts metal to oxide. Corrosion is accelerated when in contact with dissimilar metals such as aluminum and steel, or any material that absorbs moisture like wood, rubber, or dirt.



The primary means of detection of corrosion is visual. The most obvious sign is a corrosive deposit of white powder. Other signs are discoloration of the metal surface or bubbles and blisters under the painted surface. Light corrosion may be removed by light hand sanding or chromic acid. Moderate and severe corrosion (blistering, flaking, and pitting) may be removed by heavy sanding or grinding, and applying chromic acid. If significant loss of skin material thickness will result after corrosion treatment, reinforcement or replacement of the affected area may be necessary.

After removing the corroded area, restore area to original finish (prime and enamel). BOESHIELD T9, Corrosion X, or ACF-50 may also be applied to stop corrosion. Refer to manufacturer's instructions for application instructions.

Maintaining the float inside and outside finishes by washing after saltwater operations will help protect the float from corrosion. Periodically all hardware should be covered with a waterproof grease or Paralketone. Under saltwater conditions, bolts should be removed at least once a year and grease reapplied to the shafts, heads and nuts.

NOTE: The above cleaning techniques are vital for keeping corrosion to a minimum. Saltwater operations and environment are strongly linked to corrosion and must be addressed proactively.

1.15 MEANS FOR LEVELING

The airplane is leveled to "level flight attitude". See Float Handling, Jacking, and Aircraft Towing section of this manual. The airplane should be in this level position for aircraft weighing and other maintenance/installation items that require the aircraft to be in level flight attitude. The airplane is in level flight attitude when the top (right next to the side of the fuselage) of the L/H Main Gear Float Attach Fitting on airplane is at an angle of 5 degrees (tail down) from level. To measure this angle, use an electronic level placed atop the Main Gear Float Attach Fitting on airplane.

On aircraft equipped with the aluminum engine air scoop on the bottom of the cowling (non-ram air induction system), there are two small screws provided on the left hand side of the engine air scoop that provide a level reference. When a bubble level is aligned with the heads of these screws, the bubble level will indicate level when the aircraft is level.

THIS PAGE INTENTIONALLY LEFT BLANK

CHAPTER 2 MAIN GEAR AND NOSE GEAR OPERATION, REMOVAL AND SERVICE

CONTENTS

2.1 DESCRIPTION AND OPERATION	22
2.2 SERVICE – NOSE GEAR	23
2.3 NOSE BOX TRACK WEAR	23
2.4 SERVICE – MAIN WHEELS AND BRAKES	23
2.5 SERVICE – MAIN GEAR OLEO.....	23
2.6 SERVICE NOSE AND MAIN GEAR RAMS.....	28
2.7 ADJUSTMENT/TEST	28
2.7.1 NOSE GEAR.....	28
2.7.2 MAIN GEAR.....	28
2.7.3 BLEEDING HYDRAULIC SYSTEM AFTER SERVICE	29
2.7.4 HYDRAULIC ACCUMULATOR SERVICE.....	29
2.8 MAIN AND NOSE GEAR REMOVAL AND DISASSEMBLY	29
2.8.1 REMOVAL OF MAIN GEAR OLEO	29
2.8.2 REMOVAL OF MAIN GEAR RETRACTION CYLINDER.....	29
2.8.3 REMOVAL OF MAIN GEAR DRAG LINK	30
2.8.4 REMOVAL OF NOSE GEAR TROLLEY ASSEMBLY FROM NOSE BOX	30
2.8.5 REMOVAL OF NOSE GEAR BOX	30
2.8.6 REMOVAL OF LOWER NOSE GEAR FROM PIVOT BLOCK	30
2.8.7 TO REMOVE THE NOSE GEAR.....	30

CHAPTER 2 - MAIN GEAR AND NOSE GEAR OPERATION, REMOVAL AND SERVICE

2.1 DESCRIPTION AND OPERATION

Retraction and extension of the main and nose landing gear is effected by a hydraulic actuation system shown schematically in figure 2.1.

The gear system is hydraulically actuated and driven by two hydraulic pumps located in the fuselage station 159.5.

A pressure of between 525 and 1250 psi is maintained in the supply line. When the pressure falls below 525 psi, the pressure switch activates the pump solenoid, providing power to the pump. When the pressure reaches 1150-1250 psi, the pressure switch deactivates the solenoid and the pump motor stops. Figure 2.2 shows the electrical schematic of the system. A check valve on the output side of the pump retains pressure in the system while the pump is off. The pump has an internal relief valve, which directs oil back to the pump reservoir when the line pressure exceeds 1450 psi. The system also has an internal relief valve to protect against thermal expansion when line pressure exceeds 2000 psi.

A cockpit mounted control valve accomplishes the selection of gear up or gear down. Each float gear has individual indicator lights on the control valve allowing the pilot to confirm that each gear has fully retracted or extended. An emergency hand pump is provided, in case of total electric pump failure, or loss of fluid. The reservoir has additional hydraulic fluid, available only to the hand pump.

The main gear is mechanically locked in both up and down positions. Locking and unlocking is effected utilizing a small amount of lost motion of the actuator rod. Retraction takes place when pressure is exerted on the actuator piston driving the collar along the slide tube. The lock is tripped when the follower slides up the contoured track in the actuator as shown in figure 2.4. A reverse process affects extension. Gear position light proximity switches are closed when the appropriate hook (containing the magnetic material) nests over the locking bar.

Shock absorption for the main landing gear is provided by a hydraulically dampened air spring. Figure 2.5 shows the main components. The oil and air share a common chamber. When the oleo is collapsed, the oil is forced through the main orifice, compressing the air in the upper cylinder. Extension reverses this process. The extended oleo is initially set at the factory to 250 psi no load. In-field adjustment of air pressure and oil volume is described in section 2.2

The nose gear has an over-center down lock. Retraction occurs when pressure is applied to the forward face of the actuator piston and the carriage is drawn along the tracks in the nose box as shown in figure 2.9. Gear position light proximity switches are closed when the piston containing the magnetic material has reached either end of its travel.

The nose gear consists of composite fiberglass beams that are attached at the bottom to castoring blocks. Inside the block is a castoring pin that is set into the machined fork assembly. The castoring pin allows the nose wheel to pivot in a complete circle. The geometry is such that no shimmy dampers are necessary. A spring loaded ball rides in a groove machined in the castoring pin. This groove has a round pocket on the back face with the result that the cam provides retention of the pin in the block and self-centering of the wheel. A thrust bearing is on top of the castoring pin, along with a lower bearing.

2.2 SERVICE – NOSE GEAR

The nose gear pivot assembly should be cleaned and greased every 25 hours or more frequently whenever in water for extended period of time. Nose gear tracks to be lightly greased. Apply grease to a cloth on a stick or rod and run along tracks inside of the nose box, both sides.

The nose gear pivot bearings are matched to bearing and race. If replacement is necessary, replace entire bearing. The nose wheels contain grease zerks for the wheel bearings. They should be greased every 25 hours.

Nose tires are standard 6:00 x 6, 8-ply, inflated to 50 +/- 5 psi.

2.3 NOSE BOX TRACK WEAR

Due to the wear the roller/slide block places on the track as the gear are retracted, the block needs to be measured for the amount of wear. The tolerance for wear is .050 inches. If the wear is, or is less than the limit, it can still be used. If the wear in the track is greater than .050 inches, the block must be replaced. This check is to be done every annual Insp. and is part of the maintenance checklist.

On the 10000 Series Floats Gear Track P/N 13A07104 (-001 LT -002 RT).

2.4 SERVICE – MAIN WHEELS AND BRAKES

Grease nipples are provided on all wheels and bearings and should be greased every 25 hours or after an extended period of time in the water. Water/heat resistant grease is recommended.

At brake installation, apply STA-Lube synthetic brake and caliper grease or equivalent to brake caliper pins.

The dual piston brakes need no special care other than to maintain the brake disc free of rust, which causes premature brake lining wear. Bleeding is carried out in the usual manner from the bottom up. Although, since the line is "T"ed to the double brake, one must remember to bleed one segment of the Y first, then finish the entire job through the remaining segment.

Main wheel tires are standard 8:50 x 10, 8-ply type III aircraft tires, inflated to 50 +/- 5 psi. (Refer to figure 2.10).

2.5 SERVICE – MAIN GEAR OLEO

Oil Level – The correct level is best set by draining and refilling with the correct quantity of fluid (1900 ml). This should be done with the oleo removed from the float. CAUTION: Release air pressure and remove air valve before attempting to service oleo. After filling, refit valve and cap, then pressurize to 250 psi. (Note: Use only MIL-H-5606 hydraulic fluid.)

Air Pressure – The correct air pressure is 250 psi (+/-10 psi) on a fully extended oleo (no load) or it can be inflated to approximately 3-4 inches on an unloaded aircraft while sitting static on level ground.

Seals – Seals should be replaced whenever the oleo is disassembled or leaking. CAUTION: Release air pressure and remove air valve before attempting to disassemble oleo. The seals are standard "O" rings whose part numbers are depicted in figure 2.5

NOTE: When reinstalling the main gear oleo bolts, tighten so oleo is free to rotate.

Shock Strut Servicing

WARNING!

RELEASE PRESSURE IN STRUT BEFORE DISASSEMBLY

1. Disassemble the strut, removing both end caps. Take apart the gland section and metering tube so the parts can be easily inspected for wear and replacement parts can installed as needed.



2. Inspect all parts carefully after cleaning for wear and scoring, especially the piston, gland section, and the inside of the outer cylinder. Also make sure to check the bushings in the end-caps for wear and security.
3. The metering tube does not need to be taken apart from the end-cap of the inside cylinder unless extensive cleaning is desired. If it is disassembled:
 - a. To return the metering tube height and condition to factory preset, first apply blue Loctite to the threads of the inner end-cap threads that hold the metering tube for added security until next removal.
 - b. The metering tube is threaded until the measurement from the floor of the inside of the end-cap to the end of the inserted metering tube is 13.875 inches.
 - c. Tighten the associated jam nut at that end and stake it for added security.
 - d. Set this metering tube assembly aside and move on to next steps.

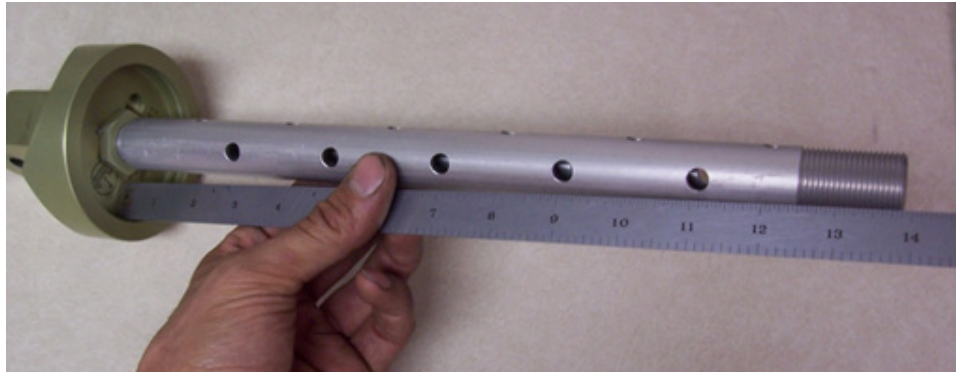

4. On the other end, install the metering tube with Loctite onto the end-cap and tighten to approx. 30 ft./lbs.
5. Install outer T-seal to end-cap with Vaseline. Install inner cylinder into top end cap with PR-1422.



6. Install the end-cap bolts with gasket sealer on the threads for added security. Tighten to 25-30 in./lbs. making sure not to over-tighten, damaging the T-seal. Set this part of the unit aside and move on to next steps.



7. To assemble the gland assembly, insert the inside T-seal and wiper, again using Vaseline on the T-seal.
 - a. The gland must be installed from the end-cap side (this is the side without the holes).
 - b. Lube the outside of the inner cylinder with hydraulic fluid for ease of assembly.

- c. Install the T-seal into the end-cap, again using Vaseline for lube.
- d. Install the inner cylinder into the end-cap (the end of the tube without holes).

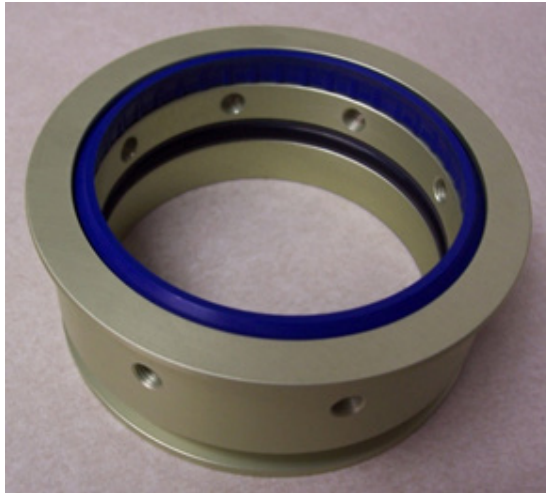

- 8. For piston install, place the piston onto the metering tube using hydraulic fluid for lube to prevent damage to the threads.
- e. Using a spanner wrench, tighten the piston to the inner cylinder.
- f. Install the jam nut onto the piston end of the metering tube and stake for security.
- g. Install the 2 T-seals onto the exterior of the piston and gland, and lube with Vaseline.



- 9. Gently clamp the outer tube end in a vise and add 1900 ml of hyd. fluid (5606 or equivalent).
- 10. Lube the inside of the outer cylinder where the gland and the piston will rest.
- 11. Install the inner cylinder into the outer assembly, making sure that the gland is seated against the piston.



12. Re-install the center bolts using gasket sealer.



13. Install the O-ring onto the fill/drain plug before installing the plug onto the end-cap.



14. Install the O-ring onto the Schrader valve and install onto the outside of the end-cap.

NOTE: Align Schrader valve 180 degrees from the Placard.

NOTE: Double check the plugs and bolts for proper Installation and security before adding gas charge.

15. Fill the strut with nitrogen to 250 psi +/- 10 psi and close the valve and cap.

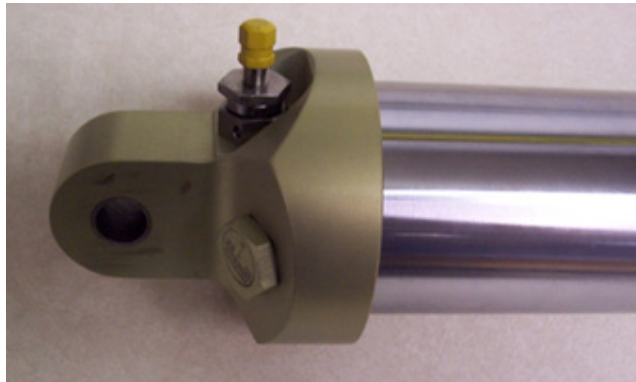

2.6 SERVICE NOSE AND MAIN GEAR RAMS

Lubricate the nose and main gear cylinder mounting flanges with MIL-H-5606 Hydraulic Fluid thru the oilers. The nose has a flip-lip type oiler and the mains have a ball-needle type oiler. The purpose is to wet the felt wiper so it pre-lubes the penetration rams and enables the seals inside to work and not become damaged over time.

2.7 ADJUSTMENT/TEST

2.7.1 NOSE GEAR

Adjustment of actuator stroke is provided at the ends of the piston rods.

The length of the nose gear rod is adjusted such that the over-center knuckle (brass) rollers just bottom out on the down side and the piston just bottoms out on the mounting flange at the same time.

The up stops nests in the up-stop bolt. See figure 2.9 and 2.10 for locations and assembly.

Nose gear proximity switches are located on clips that are mounted on the outer cylinder body, one on each end. The most forward switch is for the gear down lights and most aft is for the gear up position lights. Set the proximity switch mounting clip along outer cylinder body to a position such that the light goes out when the over-center track is about ¼ inch from bottomed position while traveling in the up direction. Lights should come on about 1/8 inch from the bottomed position while traveling in the down direction.

The cylinder piston has a magnet that will activate the proximity switches.

2.7.2 MAIN GEAR

The main gear actuator cylinder is not adjustable. These are pre-set at the factory to ensure that the main gear is locked at the end of each stroke and that correct indication is given on the cockpit console. The up and down lock may be adjusted so the lock is fully engaged by adjusting the set screws shown in figure 2.4. Loosen the jamb nut adjust and tighten jamb nut.

The service intervals on the Main Gear Actuators should be every 25 hours if the aircraft is regularly taxiing on sand and gravel. Otherwise they should be cleaned and serviced according to the checklists from the back of this manual. Clean the slide tube with clean solvent remove any build up of dry or dirty lubricants. Inspect the slide tube for erosion and/or nicks and protrusions caused by gravel or debris being thrown by the Main Landing Gear tires. Grease the actuator mechanism with HCF grease, p/n 605, or equivalent and wipe the slide tube down with a clean rag soaked in lubricant.

The main gear proximity switches are located on each end of the gear stroke. The forward switch is located on the forward side of the gear tunnel. It is accessible through the top deck access cover. The aft proximity switch is located on the float bulkhead just aft of the wheel well, accessible through the float top deck cover.

The main gear proximity switches are adjusted loosening the mounting screws and positioning them as such that the light goes out when the lock hook is raised about 1/8 inch off its nested position and comes on again upon nesting.

2.7.3 BLEEDING HYDRAULIC SYSTEM AFTER SERVICE

The system automatically bleeds, provided sufficient oil is maintained in the reservoir. To check the fluid level, fill the reservoir with hydraulic oil and cycle the gear. You should notice that the reservoir level drops significantly when the system pressure builds as the accumulator is filling with fluid. You will have to add more fluid at this time. Conversely, when opening a connection in the system a discharge of fluid under pressure will occur as the accumulator empties itself.

Once the accumulator is full the fluid level should be maintained in the upper one third (1/3) of the sight glass. If the reservoir empties (i.e. fluid disappears in sight glass) stop the cycle by pulling the circuit breaker on the control panel. Fill the reservoir again and complete the cycle. Continue this procedure until the fluid level in the reservoir stabilizes (it will vary in level between up and down positions). If the fluid level continues to decline during gear cycles, check for external leaks. Generally, the fluid level in the sight glass should be about 3/4 full when the gear is down.

2.7.4 HYDRAULIC ACCUMULATOR SERVICE

The accumulator is pre-charged with nitrogen to a pressure of 225 psi. If recharging becomes necessary (slower than normal probe retraction time of 1 second). Recharge with dry nitrogen gas to a pressure of 225 psi.

2.8 MAIN AND NOSE GEAR REMOVAL AND DISASSEMBLY

2.8.1 REMOVAL OF MAIN GEAR OLEO

Jack the aircraft by method described in section 1.2. With main wheels off the ground (both sides), run the gear up so that the main carriage is approximately 2 inches forward of down lock position. This must be accomplished to remove the top oleo bolt. In order to remove the lower bolt, it is necessary to remove the wheel on the head side of the bolt.

2.8.2 REMOVAL OF MAIN GEAR RETRACTION CYLINDER

Relieve pressure in system, place gear selector handle in neutral position (lever between up and down), and remove hydraulic lines. Remove end cap from end of cylinder. Drain fluid. Remove forward end of cylinder from bulkhead flange. Remove both cylinder support rings from the bulkhead. NOTE: Piston to be in the up position

for cylinder removal. Remove cylinder from piston and up through top float inspection cover. To remove the piston, remove top inspection cover on top forward end of gear tunnel, accessible from the top float inspection cover forward of the step. Pull back piston to expose top of carriage in center of access cover. Remove .25 dia. retention bolt. Remove piston by pulling aft. See figure 2.6 for part breakdown.

2.8.3 REMOVAL OF MAIN GEAR DRAG LINK

Remove drag link from trunnions on step bulkhead. Axle is heat shrunk to drag link and is not removable.

2.8.4 REMOVAL OF NOSE GEAR TROLLEY ASSEMBLY FROM NOSE BOX

Gear must be in down position. Unbolt the spring from the trolley. Relieve the pressure in system, place gear selector handle in neutral position (lever between up and down), and remove rear hydraulic line. Remove (4) bolts on forward end of cylinder. Drain fluid. Pull aft to expose internal piston rod. Loosen jamb nut on forward side of cylinder ram at rod end. Turn piston from aft side of nose box out of rod end. Push on trolley assembly to unlock and remove the bottom thru-bolts. Slide out of nose box. Note: On installation, adjust piston so it bottoms out on aft flange at the same time as the bearings when nose gear is in locked position. Also note orientation of trolley blocks. The side with the most edge distance from hole is to go toward each other on inside of trolley. (See figure 2.9 for details).

2.8.5 REMOVAL OF NOSE GEAR BOX

Remove bolts securing forward box from nose bulkhead. Remove bolts securing aft box from bulkhead (2). Slide box out from front of float.

Note: Sealant will have to be cut for removal and replaced when installing.

2.8.6 REMOVAL OF LOWER NOSE GEAR FROM PIVOT BLOCK

On top of pivot block, remove cotter pin from retaining nut. Remove nut. On aft side of pivot block, remove the (2) cap bolts on .25 thick cover. Remove spring. This will loosen retaining ball and lower fork will slide out. Refer to figure 2.10 for assembly.

2.8.7 TO REMOVE THE NOSE GEAR

Remove the nose gear from the nose box by unbolting the spring (4 bolts).

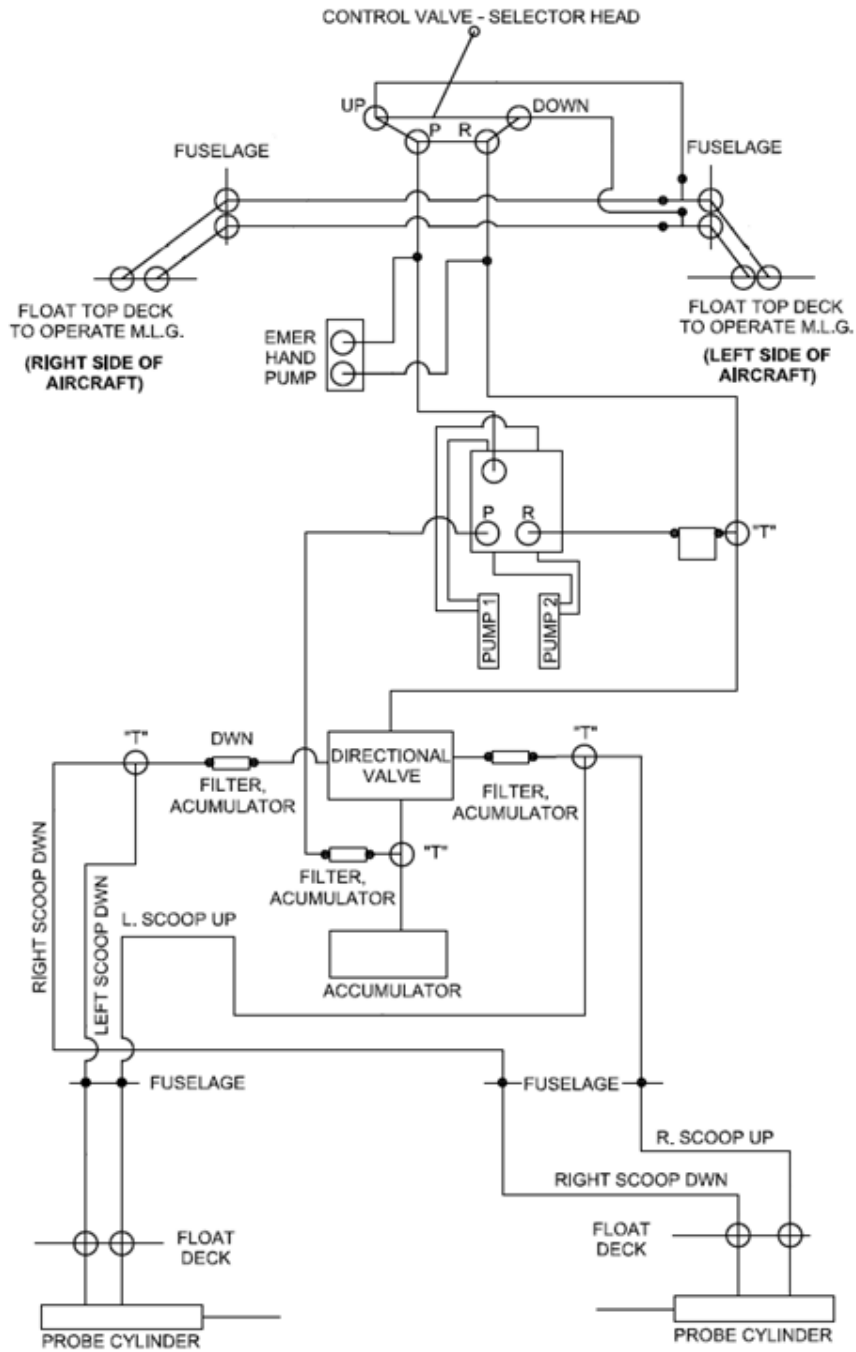

FIGURE 2.1 SCHEMATIC - HYDRAULIC SYSTEM

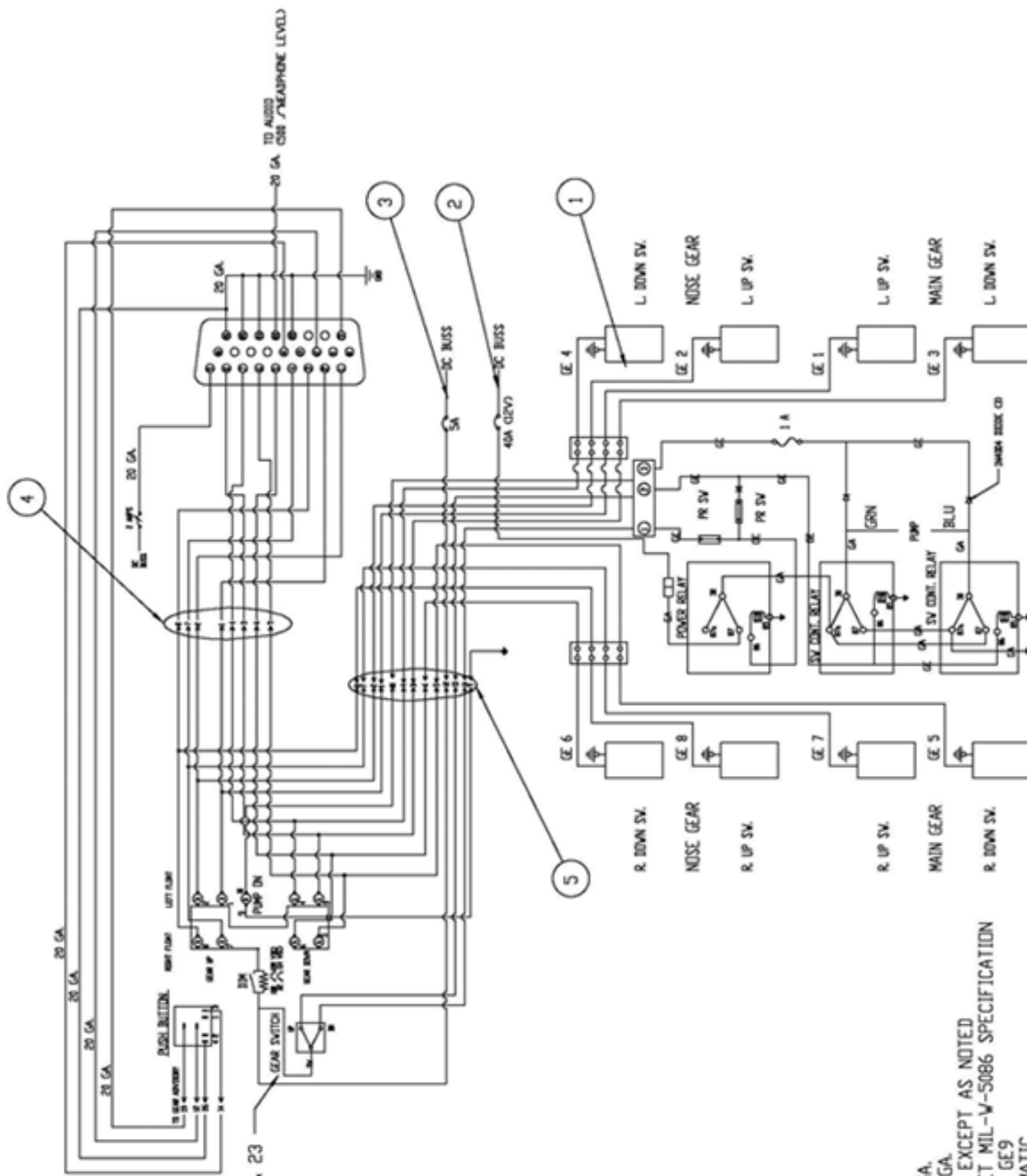

FIGURE 2.2 SCHEMATIC - ELECTRICAL SYSTEM

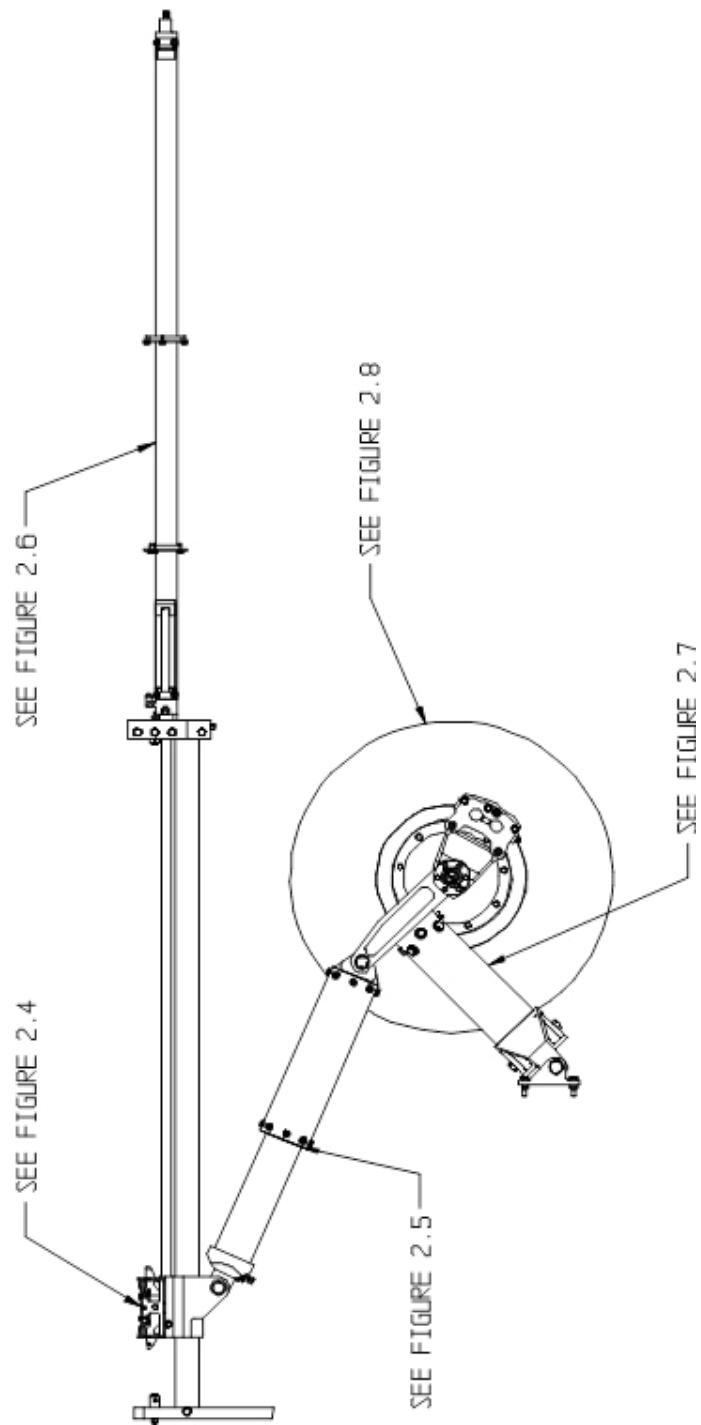

FIGURE 2.3 LAYOUT – MAIN GEAR

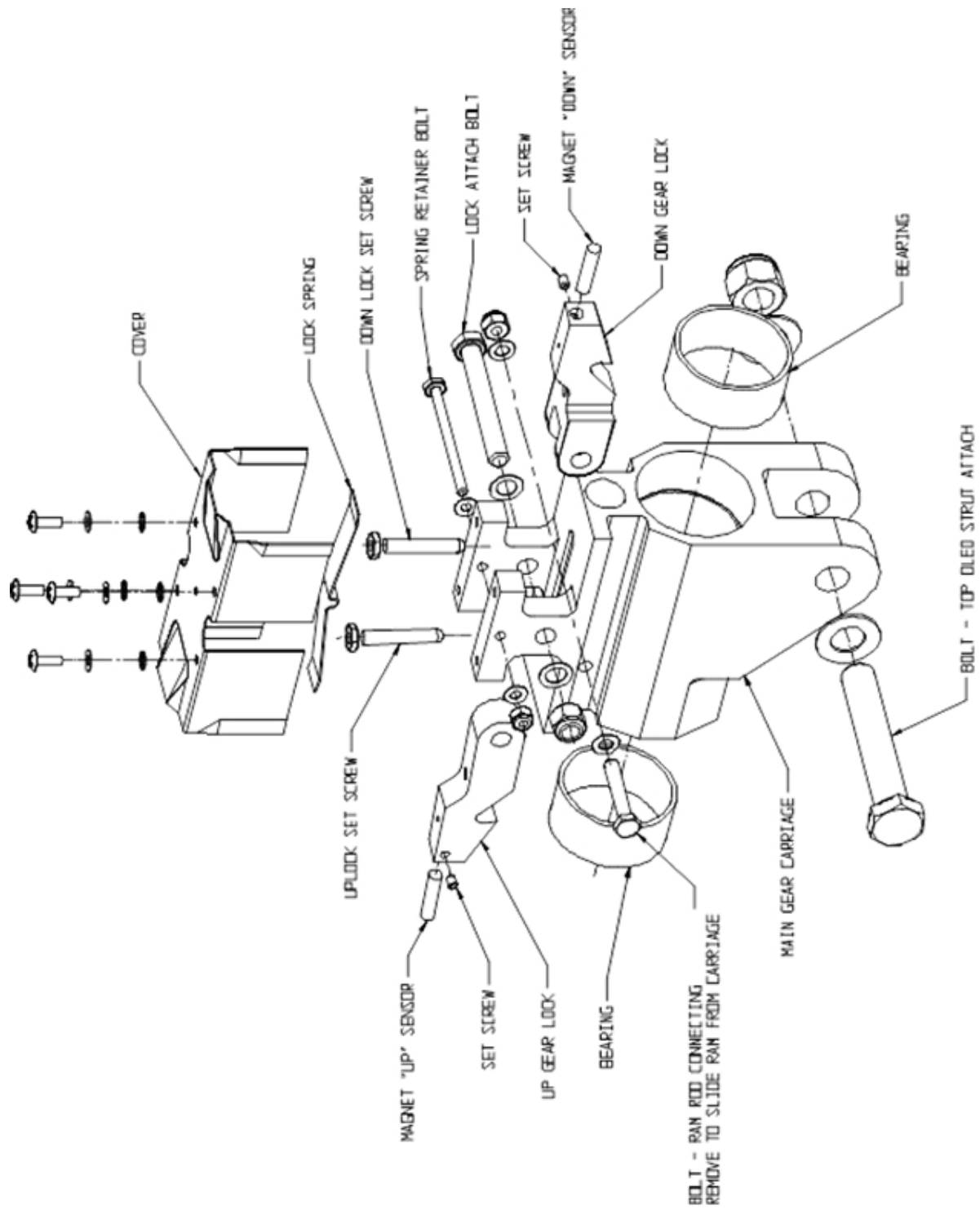
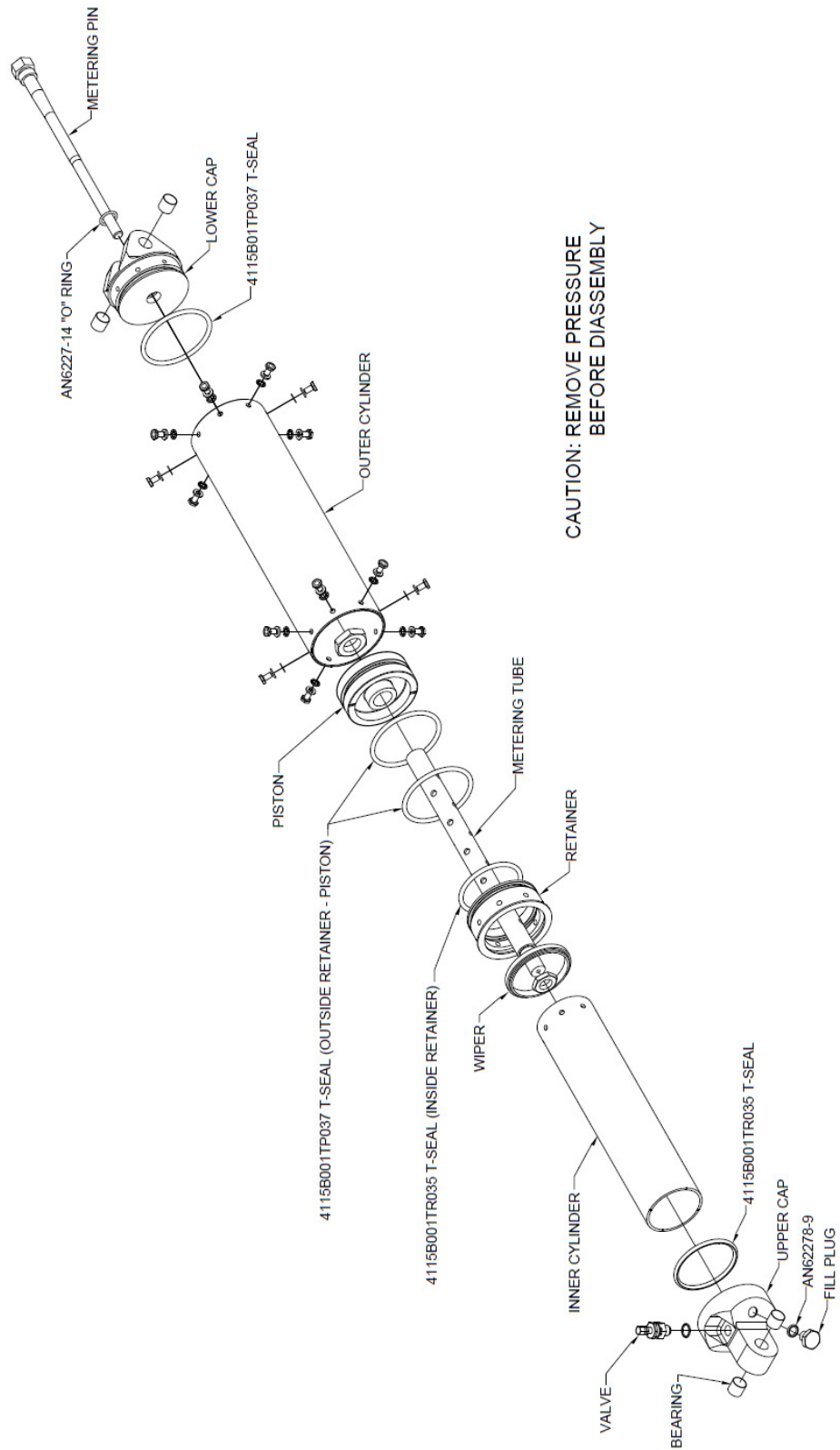

FIGURE 2.4 CARRIAGE ASSEMBLY – MAIN GEAR



CAUTION: REMOVE PRESSURE
 BEFORE DIASSEMBLY

FIGURE 2.5 ASSEMBLY – MAIN GEAR SHOCK STRUT

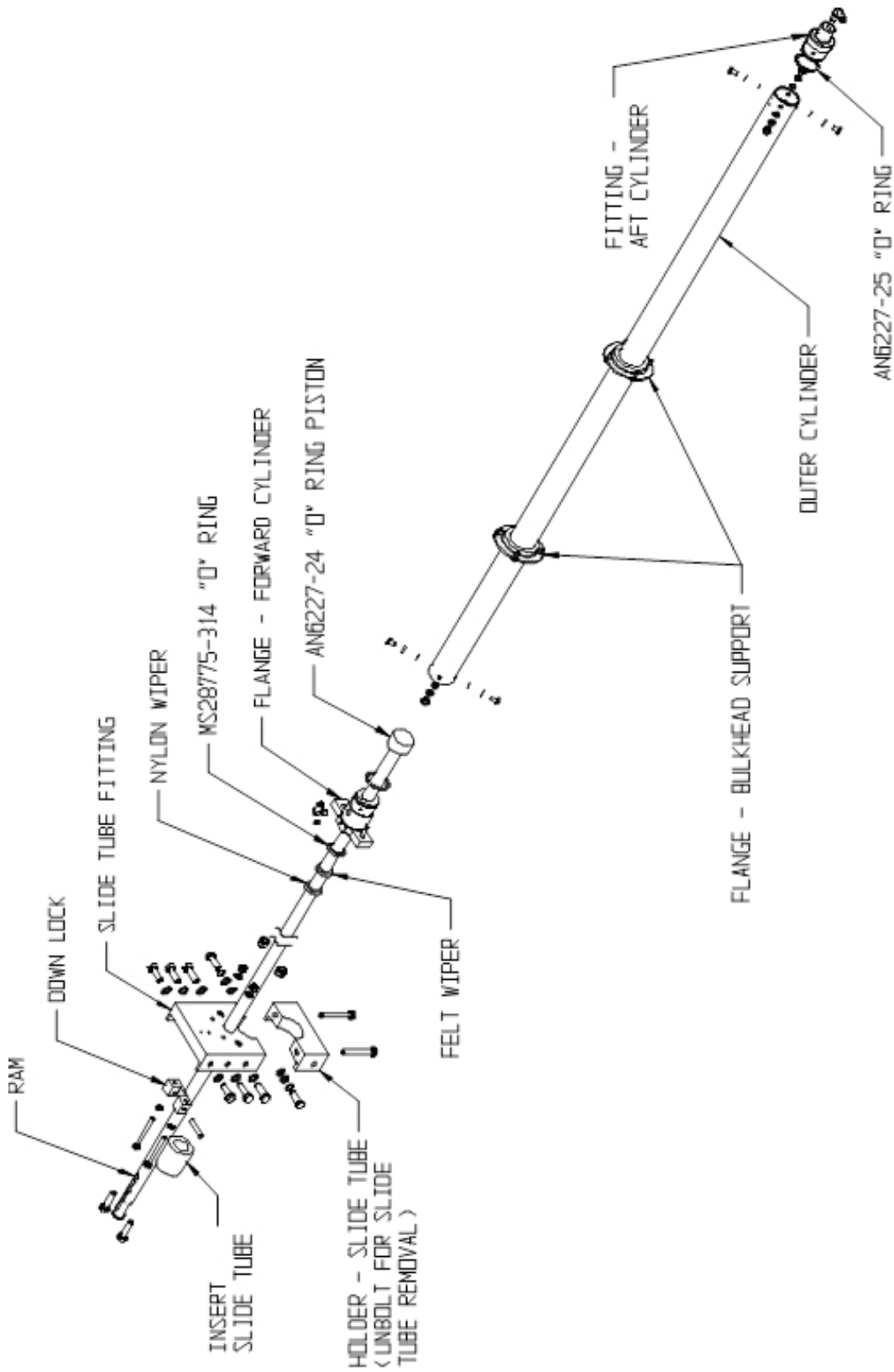

FIGURE 2.6 ASSEMBLY – MAIN GEAR ASSEMBLY

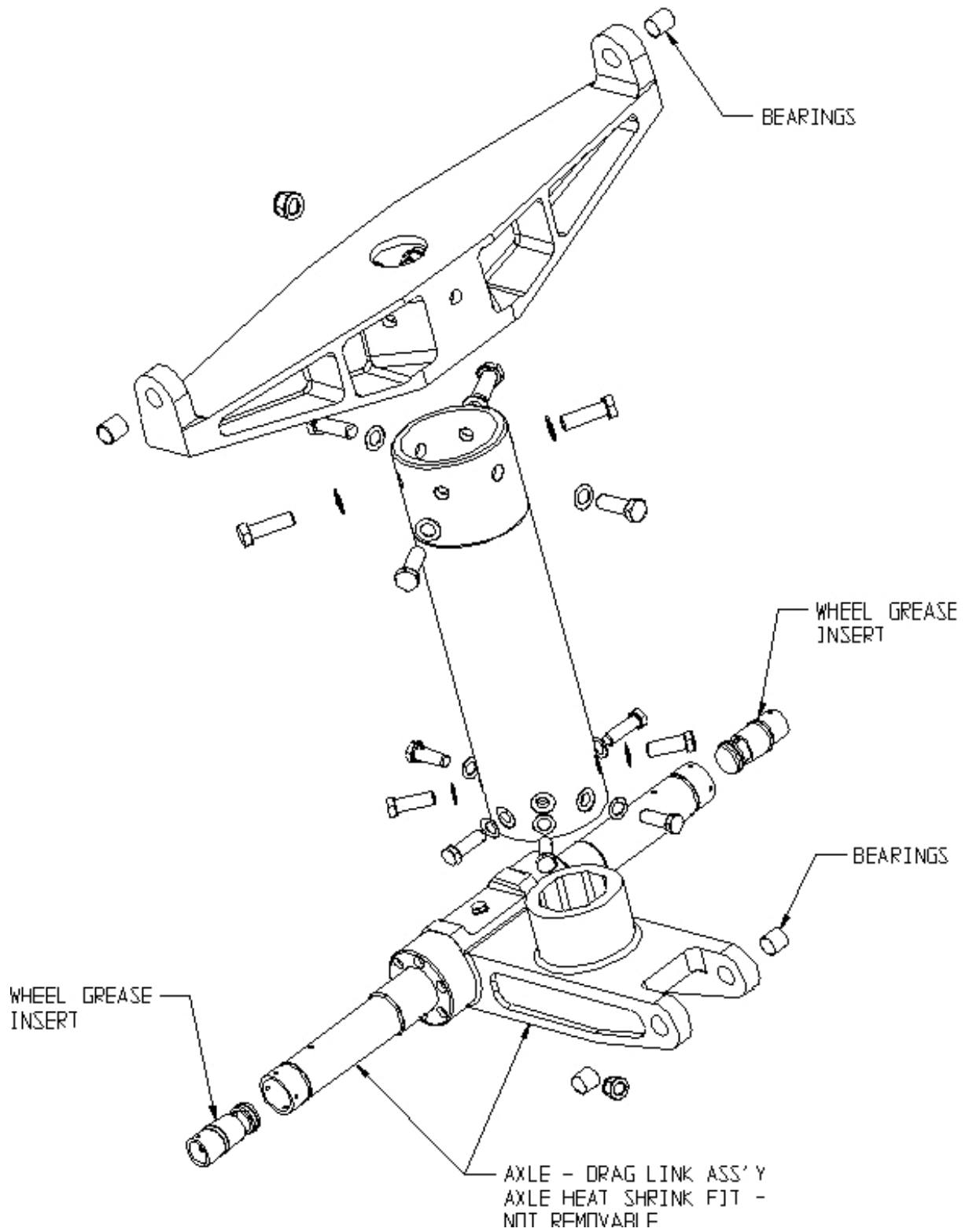

FIGURE 2.7 ASSEMBLY – MAIN GEAR DRAG LINK

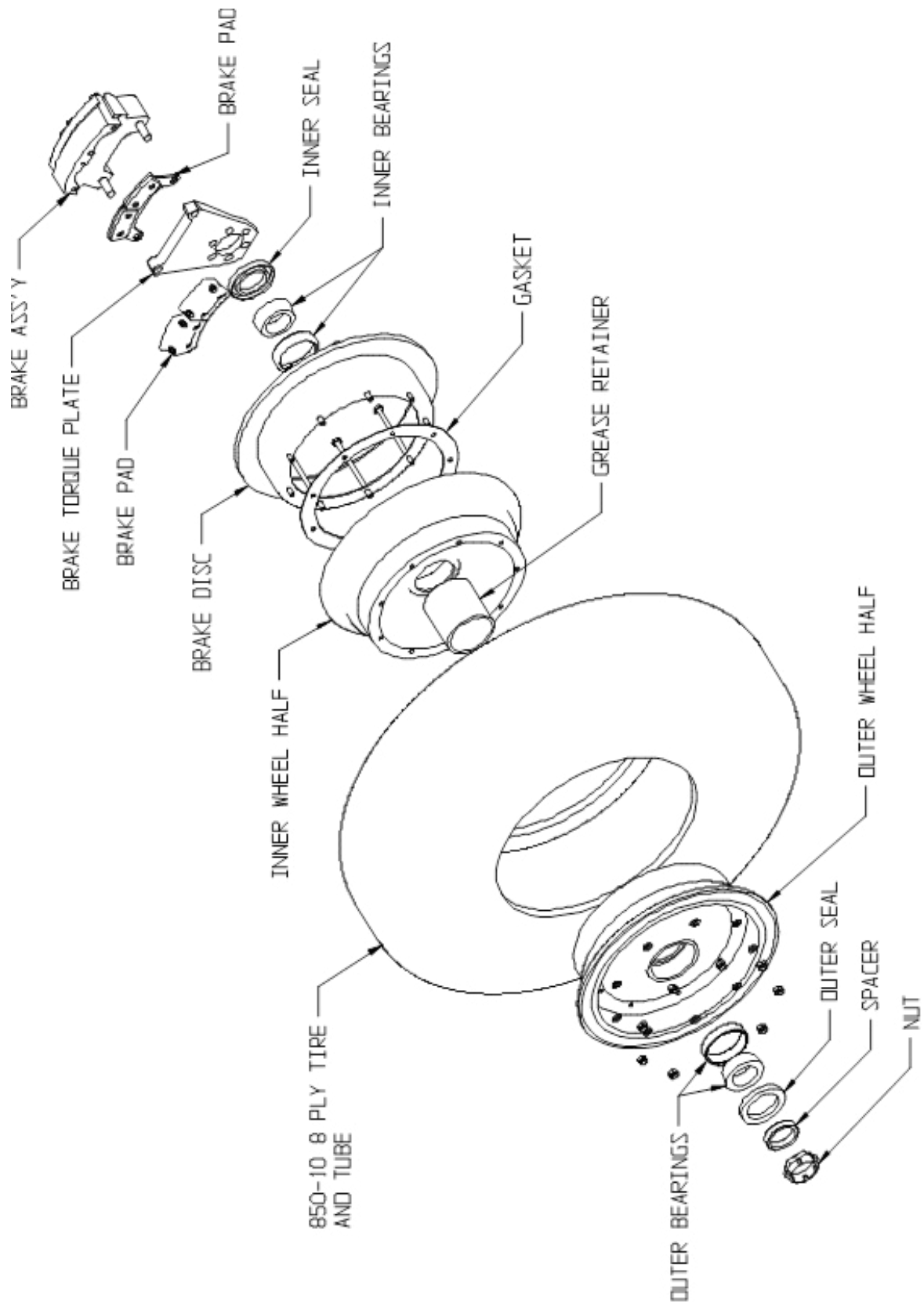

FIGURE 2.8 ASSEMBLY – MAIN GEAR WHEEL AND BRAKE

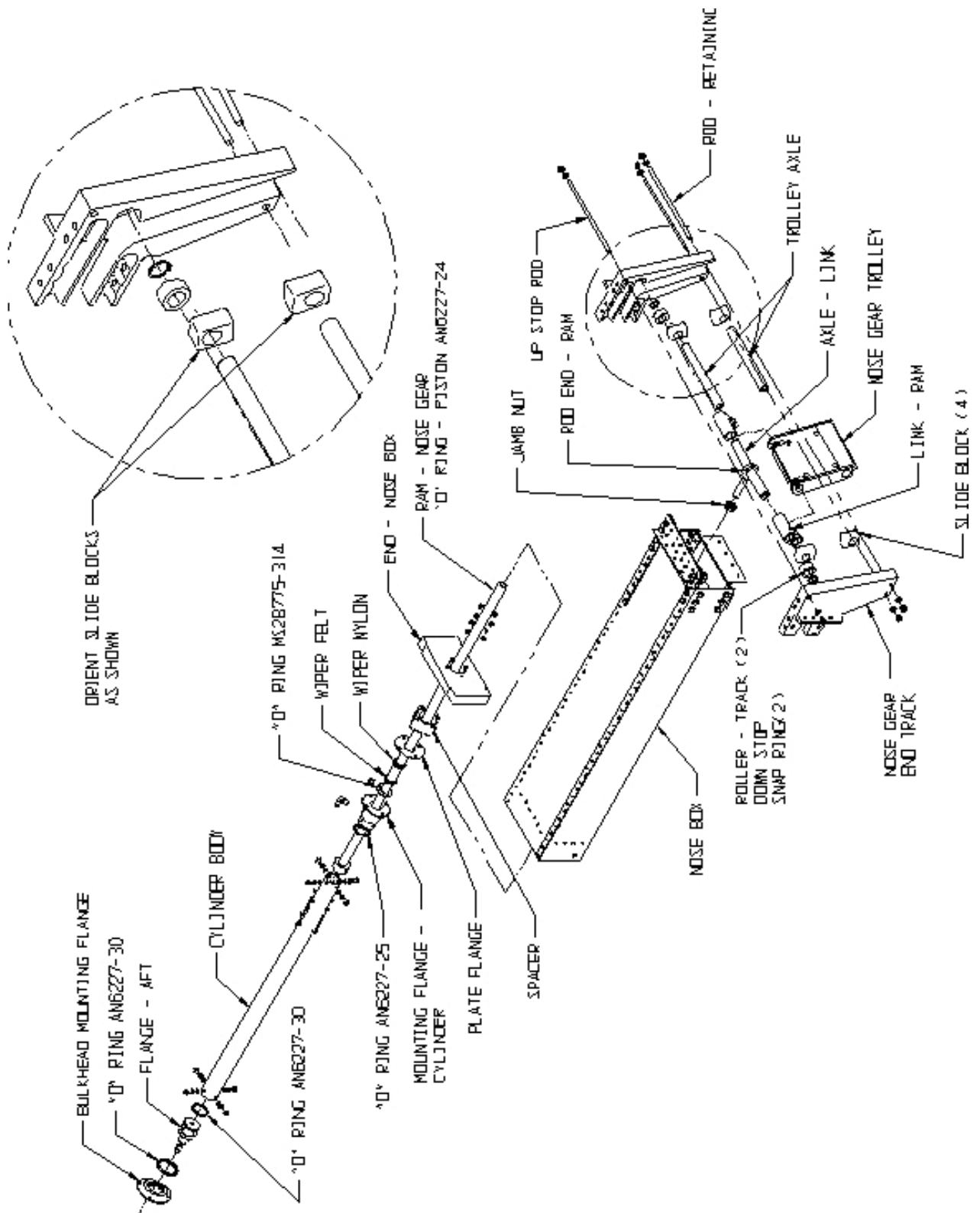

FIGURE 2.9 ASSEMBLY – NOSE GEAR BOX AND RETRACTION

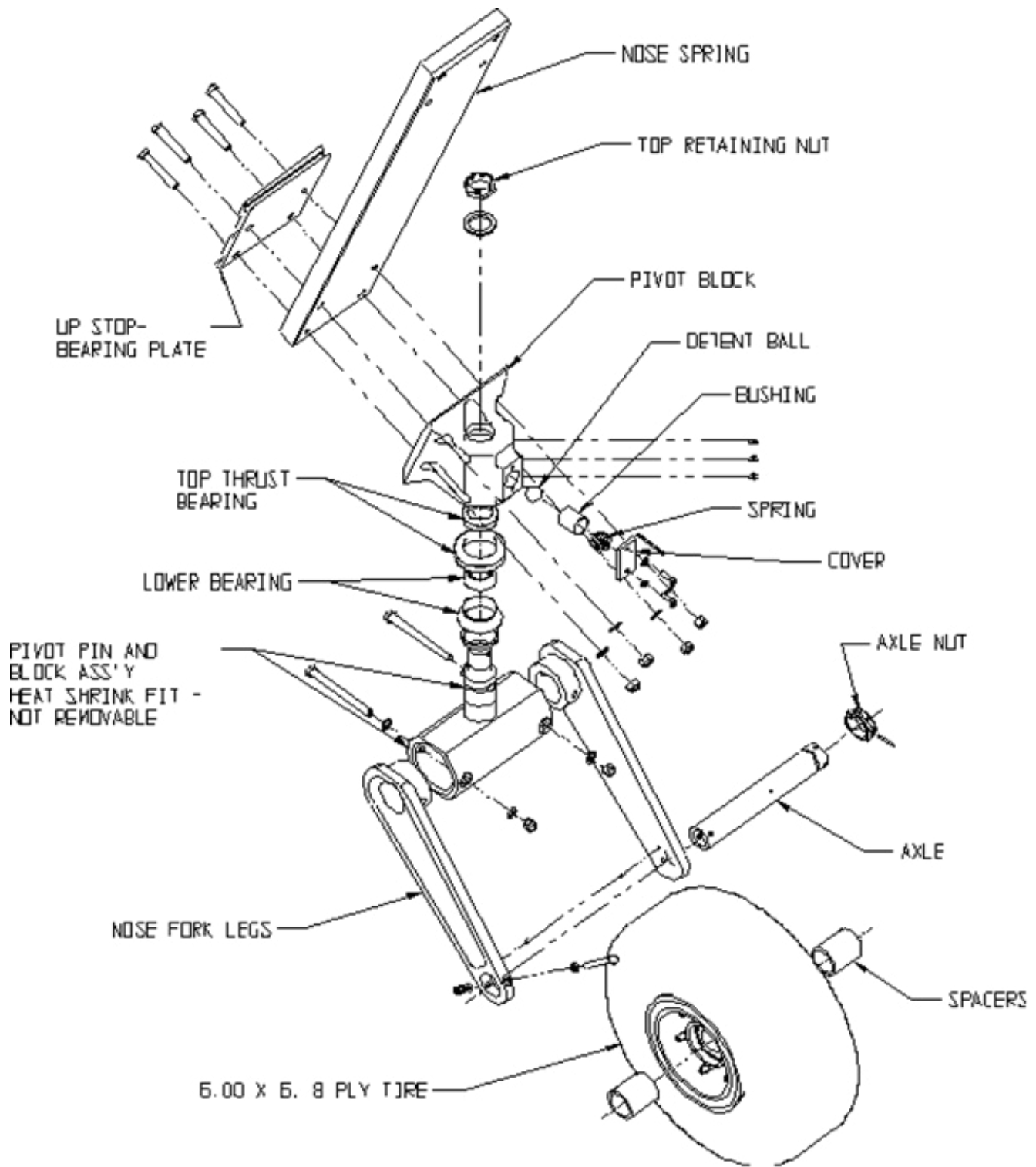

FIGURE 2.10 ASSEMBLY – NOSE GEAR LOWER END

CHAPTER 3 HYDRAULIC PUMP SYSTEM, DISASSEMBLY AND SERVICE

CONTENTS

GENERAL	42
3.1 OPERATION TROUBLESHOOTING	43

CHAPTER 3 - HYDRAULIC PUMP SYSTEM, DISASSEMBLY AND SERVICE

GENERAL

The hydraulic pump is factory preset to the following pressures:

Pressures switch operates below 525 psi and shuts off at 1250 psi.

The pump also has an internal relief valve that opens at 1450 psi and a thermal relief valve that opens at 2000 psi. These pressures are set with factory test equipment and are recommended to be sent back for overhaul or repair.

The unit may be disassembled for cleaning.

1. Relieve the pressure in the hydraulic system by placing the gear selector handle in the neutral position.
2. On the forward lower side of the reservoir, remove drain plug to drain most of the hydraulic fluid.

NOTE: Due to the confines of the hydraulic power pack installation, the power pack will need to be lifted up and supported with a ratchet strap or something similar while loosening up the clamps that will attach it to the aircraft tubing. This will lift the assembly up far enough to remove the reservoir.

3. Remove the (4) screws on each tank (2) on upper side of the reservoir.
4. Dump out remaining oil, and clean reservoir.
5. Unscrew stand pipe with the filter screen attached.
6. Clean filter screens.
7. If filter screens are removed from stand pipe, a new filter screen should be used.
8. Reinstall tank and install seals to top of reservoir before installing on pump.
9. Install drain plug and fill with clean MIL-H-5606 hydraulic fluid through the breather pipe.
10. Fluid level should be in the upper 2/3 of the sight gauge
11. Remove and clean all the in-line 10 micron filters located above and adjacent to the accumulator, aft of the hydraulic pumps on the pressure line.
12. If the fluid is not a clean, red color, it should be replaced with new fluid.

3.1 OPERATION TROUBLESHOOTING

1. PROBLEM – Powerpack does not run after gear selection.

PROBABLE CAUSE

- a. Circuit breaker has failed
- b. Pressure switch not pulling in at low cut in.
- c. Solenoid switch not pulling in.
- d. Faulty pump motor.
- e. Motor not properly grounded.

VERIFICATION AND REMEDY

- a. Reset circuit breaker.
- b. Short across pressure switch leads and see if motor runs. If motor operates, replace pressure switch.
- c. Short across solenoid pressure switch leads and see if motor runs. If motor operates, replace solenoid pressure switch.
- d. If c. above does not produce results and it is verified that voltage was actually applied to motor, it can be assumed motor is bad or not properly grounded.
- e. Check motor ground.

2. PROBLEM – Powerpack does not shut off after gear reaches position.

PROBABLE CAUSE

- a. Faulty pressure switch.
- b. Faulty or dirty pressure relief valve allowing insufficient pressure buildup.

REMEDY

- a. Replace pressure switch.
- b. Clean and check relief valve.

3. PROBLEM – Powerpack shuts off before gear reaches position.

PROBABLE CAUSE

- a. Binding or jammed gear retractor, which causes pressure to build up (and stay up), and pressure switch shuts off powerpack.
- b. Faulty or dirty pressure relief valve allowing insufficient pressure buildup.

REMEDY

- a. Repair retractor.

4. PROBLEM – Powerpack cycles on and off after gear is in position.

PROBABLE CAUSE

- a. Internal hydraulic leak.
- b. External hydraulic leak.

REMEDY

- a. Verify leak is not external by checking fluid level in reservoir and looking at couplings for oil leaks. If no external leaks are found, disconnect and cap off the hydraulic actuators one at a time and find the leaky one by process of elimination. If isolating entire system still indicates internal leak, powerpack check valve (located in pressure port of pump) is bad and needs replacement or reseating.
- b. Visually inspect lines, cylinders, and hoses and replace as necessary.

5. PROBLEM – Powerpack cycles on and off during gear cycle.

PROBABLE CAUSE

- a. Binding in retraction unit.
- b. Pressure switch cut off limit too low.

REMEDY

- a. Investigate for free operation. Check gear that retracts last.
- b. Replace pressure switch

6. PROBLEM – Slow gear operation cycle (considerably longer than 30 seconds).

PROBABLE CAUSE

- a. Plugged oil screen.

- b. Poor electrical connection to motor.
- c. Poor motor.
- d. Worn pump gears.
- e. Low ship voltage.

REMEDY

- a. Clean intake screen located inside reservoir tank.
- b. Connect motor direct to 24 volt source and note its operation; if good, wire connection is bad; if operation poor, motor needs overhaul.
- c. Covered in b. above.
- d. Replace pump.

7. PROBLEM – Circuit breaker pops during cycle.

PROBABLE CAUSE

- a. Wire connections bad or corroded.
- b. Bad motor brushes.
- c. Bad circuit breaker.

REMEDY

- a. Clean and protect terminal with grease.
- b. Overhaul motor.
- c. Replace circuit breaker.

THIS PAGE INTENTIONALLY LEFT BLANK

CHAPTER 4 SCOOP SYSTEM OPERATION, REMOVAL, AND SERVICE

CONTENTS

4.1 DESCRIPTION AND OPERATION	48
4.2 ADJUSTMENT AND TEST.....	48
4.3 REMOVAL OF SCOOP AND FILL SYSTEM	48
4.4 SERVICE – SCOOP SYSTEM	49
4.5 SERVICE OF SELONOID VALVE – SCOOP RETRACTION.....	49
4.6 SERVICE OF IN-LINE FILTERS – SCOOP RETRACTION.....	49
4.7 ASYMMETRIC SCOOP REPORTING	49

CHAPTER 4 - SCOOP SYSTEM OPERATION, REMOVAL, AND SERVICE

4.1 DESCRIPTION AND OPERATION

Full operating information of scooping system is described in Introduction Section 1.4. The scoops (one in each float) are hydraulically operated. Hydraulic Schematic Figure 2.1 shows how the scooping system is integrated with the landing gear hydraulic system. The only moving part in the scooping system is the lower probe assembly which is actuated hydraulically by the probe jack cylinder. See Figure 4.1 for view of the entire scooping system.

4.2 ADJUSTMENT AND TEST

The lower probe assembly is set at the factory for full open and close positions. Any adjustment necessary to the probe is accomplished by adjusting the probe jack cylinder. Figure 4.2A shows a cross section of the cylinder. Figures 4.2B and 4.2C illustrate the setting of the up and down positions, respectively. Set the up position first. Begin by extending the cylinder shaft with hydraulic pressure to ensure full extension. While extended, the clevis should bolt to the probe when the bottom of the probe is clear of the float keel by approximately 1/8". Turn the clevis as necessary to meet this condition. Once the up position is set, the down position is set by adjusting the stop collar. The stop collar should meet the cylinder body when the top/inner surface of the probe is flush with the float keel. The hydraulic lines may be disconnected to facilitate adjusting and checking the down position by hand. Apply Loctite 290 (green) threadlocker or equivalent to both jam nuts and torque to 90-100 in-lbs. Jam nuts may alternatively be NAS509 or NAS1423 drilled jam nuts to be secured with safety wire. After adjustment reconnect hydraulic lines as needed and cycle probe for proper operation. Check if probe up and down position lights are operating properly.

4.3 REMOVAL OF SCOOP AND FILL SYSTEM

Lower Scoop Assembly and Scoop Cylinder

Remove attaching bolt for scoop assembly accessible from outside of the float. Drop down and disconnect the rod end from the probe jack cylinder. For removal of the cylinder, remove attaching bolt accessible from outside of the float. From inside of the float, remove forward top tunnel access cover. Remove hydraulic lines and remove cylinder.

Scoop Tube Assembly – Internal

Remove access covers on left and right side skins just forward of step. From these holes, unsafety clamp connecting the 2 scoop tubes. Remove forward leading edge fairings from the main gear pylon. Unclamp and remove the connecting hose to upper filler pipe. Remove the bolts attaching upper attach flange to the float top deck. Slide out scoop tube from the top. When reinstalling, check condition or replace gasket in connecting clamp.

Upper Probe Scoop Assembly

With the lower scoop and internal scoop tube removed, unbolt scoop from float tunnel. Break sealant and remove from the top. Reseal cover on reinstallation.

Filler Tube – Main Gear Pylon

Remove fairings, unbolt attaching clamps, and disconnect connecting hose. Remove hose. Before reinstalling, check condition or replace clamp chafing strips.

Fill Tube at Aircraft Tank

From inside and outside of tank, remove attaching bolts. Break sealant on inside and outside flanges. Remove from inside tank. On reinstallation, seal completely and reattach.

4.4 SERVICE – SCOOP SYSTEM

Figure 4.2A shows a cross section of the hydraulic probe cylinder. Replace “O” rings if cylinder shows signs of leaking. Check for security of the jam nuts against the clevis and stop collar. If needed, apply Loctite 290 (green) threadlocker or equivalent and torque jam nuts to 90-100 in-lbs. Jam nuts may alternatively be NAS509 or NAS423 drilled jam nuts to be secured with safety wire. A gasket is between upper probe and internal tube at connecting clamp. Replace if necessary. Check condition of connecting hose and clamps above float deck (2) each side. Inside of aircraft tank on each inlet tube there is a rubber flapper valve or a platypus type valve. Check if valve is closing tight and condition of valve. Replace if necessary.

4.5 SERVICE OF SELONOID VALVE – SCOOP RETRACTION

If scoop probes stick, it may be necessary to clean the Vickers solenoid valve. This valve is located aft of the hydraulic pump and above the accumulator. Remove the pressure in the hydraulic system by placing the gear selector in the neutral position (between up and down). Remove the large (.94 inch) Hex nut located on the left side of the valve. Remove nut and spring and gently remove the valve spring. Remove the electrical box cover (the one with the amber light) by loosening the two center, round knobs. Pull off electrical box. Remove solenoid block from the manifold by removing the four Allen hex-head bolts. Remove the solenoid valve from the manifold and clean by carefully blowing air through the ports. Reinstall the block with the four Allen hex-head bolts and their accompanying ‘O’-rings. Reinstall the electrical box cover. Clean the valve solenoid stem and gently reinstall it. Reinstall spring and nut.

NOTE: This above procedure should be in conjunction with cleaning of the entire hydraulic system, in-line filter elements, and removing the hydraulic pump tank and cleaning the filters in Section 3.

4.6 SERVICE OF IN-LINE FILTERS – SCOOP RETRACTION

Adjacent to the solenoid valve referred to in 4.5 are in-line filter elements. To service and clean these filter elements, unscrew them by turning the hex and nut and holding the flat on the opposite end. Remove the filter elements and note the placement of the internal springs. Clean the filter elements by washing in clean solvent and blowing compressed air through the inside. Check the condition of the O-rings before reassembly and carefully retighten the fittings.

4.7 ASYMMETRIC SCOOP REPORTING

In order to better gather fleet operational data, Wipaire needs the following information reported when a suspected asymmetrical scoop event leads maintenance to ground the aircraft to investigate the possible event:

- Date and local time
- Aircraft identifier
- Location and scooping direction
- Weather, including wind and water surface conditions
- Summary of activity preceding the event (i.e. number of scoops that day, time since previous maintenance, etc.)
- Symptoms that lead to suspecting an asymmetric scoop event occurred

-Results of the investigation

Provide the preceding information to Wipaire Customer Support as soon as practical after the maintenance action is completed.

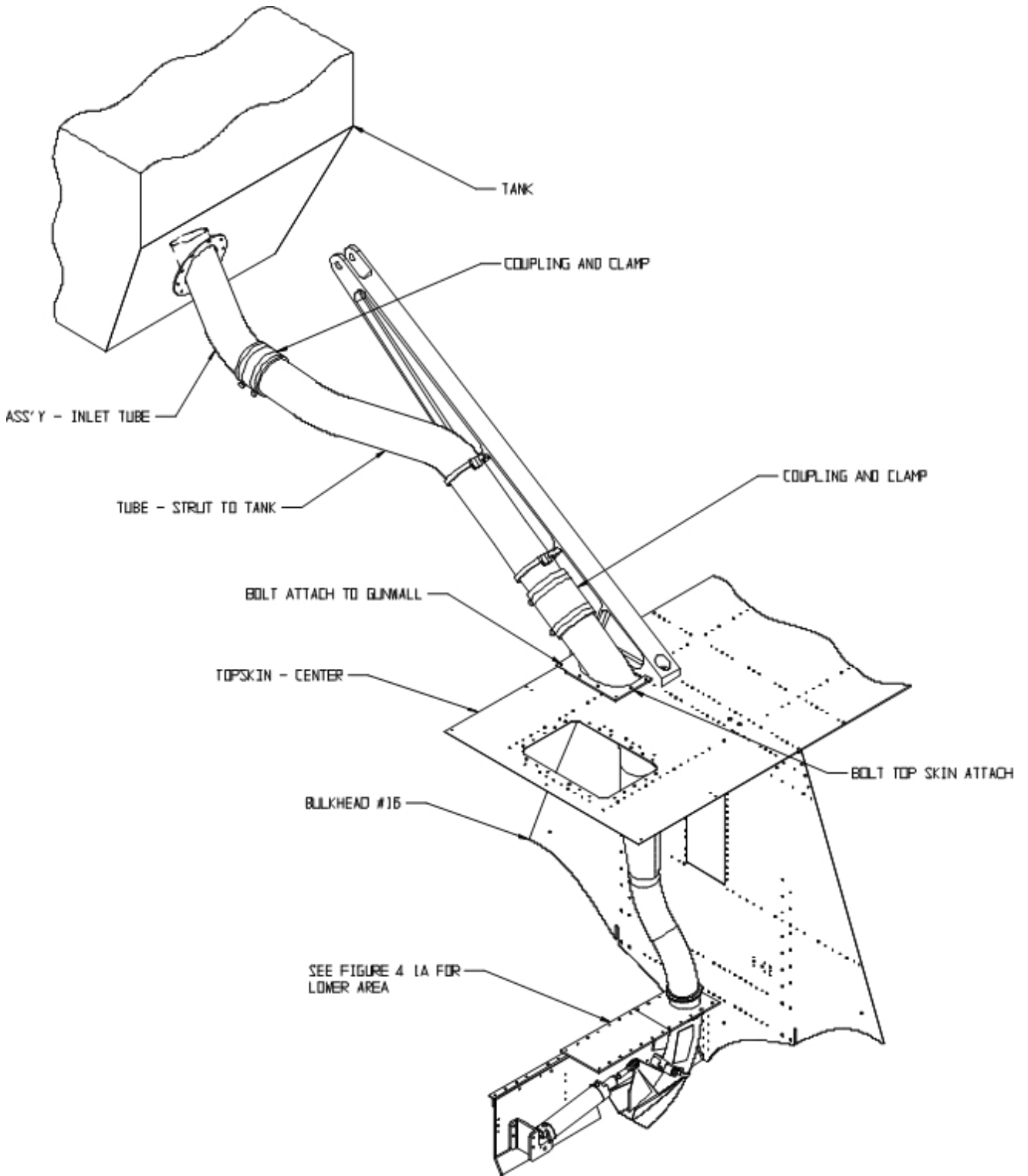

FIGURE 4.1A ASSEMBLY – SCOOPING SYSTEM - COMPLETE

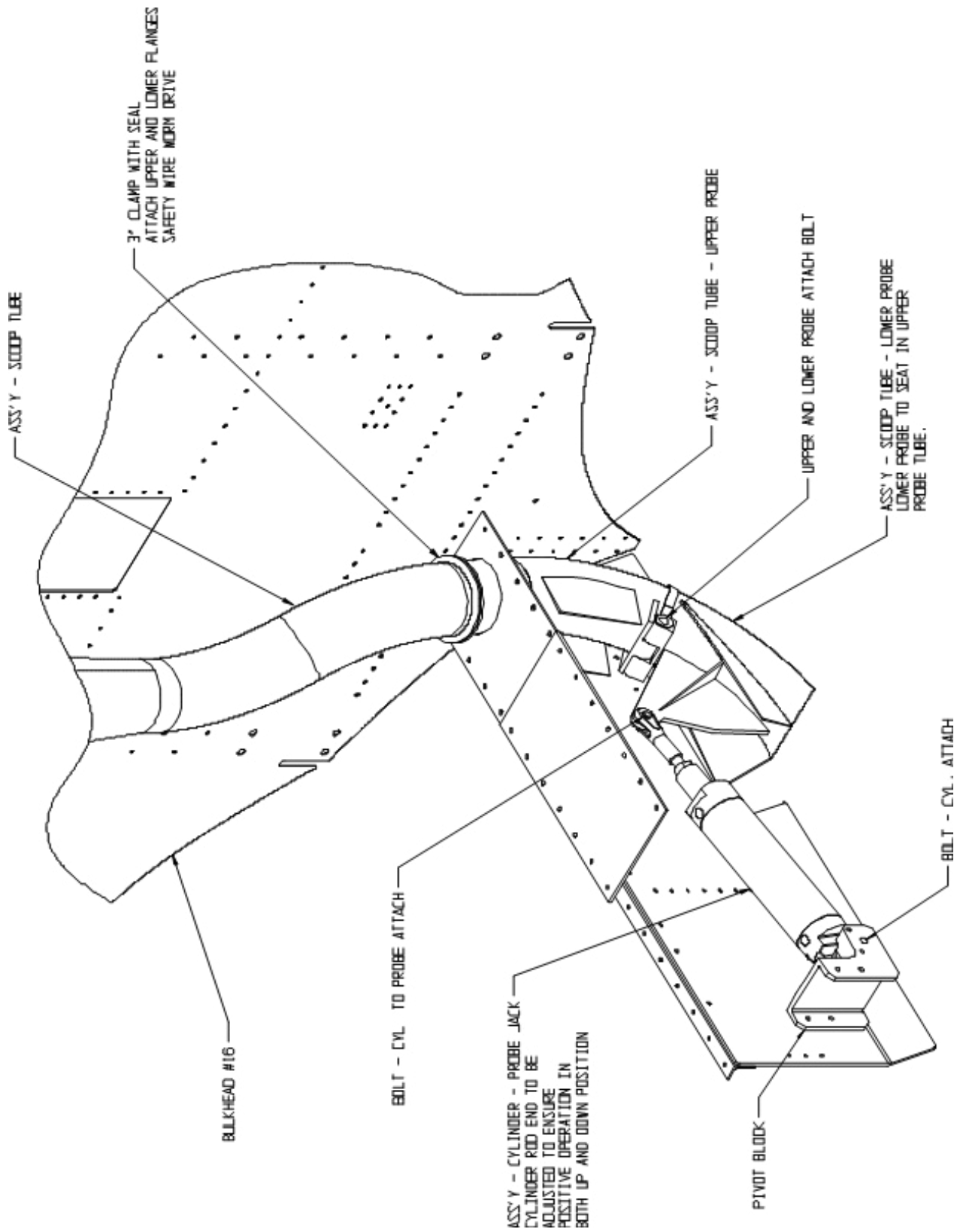

FIGURE 4.1B ASSEMBLY – SCOOPING SYSTEM

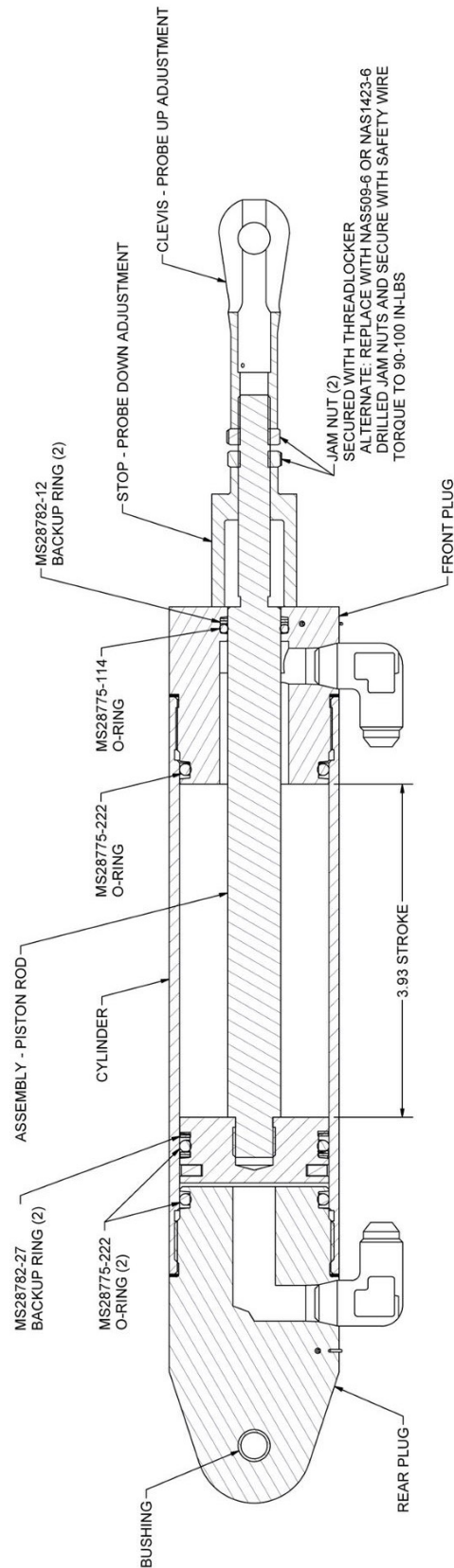

FIGURE 4.2A ASSEMBLY – CYLINDER PROBE JACK

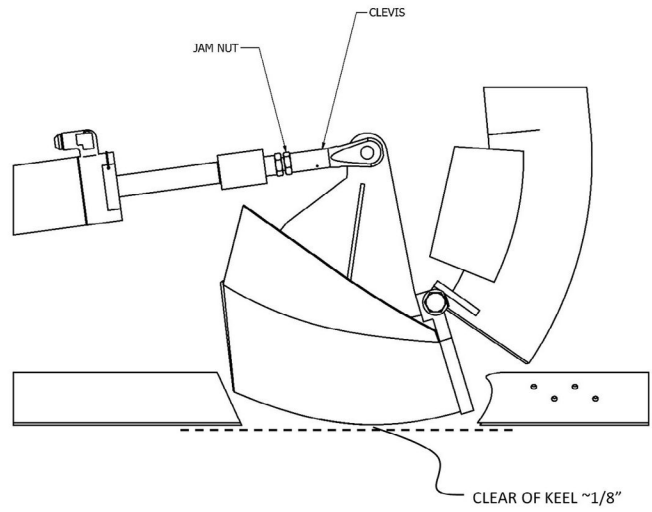

FIGURE 4.2B – PROBE UP POSITION ADJUSTMENT

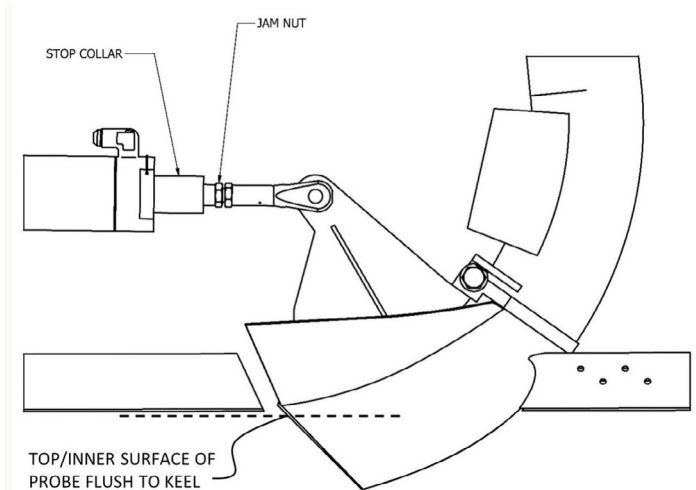

FIGURE 4.2C – PROBE DOWN POSITION ADJUSTMENT

CHAPTER 5 FOAM DELIVERY SYSTEM OPERATION, REMOVAL AND SERVICE

CONTENTS

5.1 DESCRIPTION AND OPERATION	56
5.2 ADJUSTMENT AND TEST.....	56
5.3 REMOVAL OF FOAM SYSTEM	56
5.4 SERVICE – FOAM SYSTEM	56

CHAPTER 5 - FOAM DELIVERY SYSTEM OPERATION, REMOVAL AND SERVICE

5.1 DESCRIPTION AND OPERATION

Full operating information of the entire foam system is described in Introduction Section 1.7. The foam system schematic is shown in figure 5. The main 18 gallon firewall foam tank that feeds the hoppers is stock Air Tractor system. The 18 gallon firewall tank has been modified to allow foam from the float tanks to refill that tank. A fluid level gauge also has been added. Each float has a 30 gallon tank that pumps into the firewall tank.

5.2 ADJUSTMENT AND TEST

No adjustment is necessary for this system. When pumps are running a 'pump-on' light is located on the auxiliary instrument panel.

5.3 REMOVAL OF FOAM SYSTEM

To remove tank from float, disconnect electrical plug and hose coupling from tank edges. Lift from center handle and the tank from the float through top deck. Tank should have small amount of foam in for ease of removal. The tank floor may now be removed through top deck. The 18 gallon firewall tank is a standard Air Tractor installation with a Wipaire liquid level sensor added and line routed to the float tank.

5.4 SERVICE – FOAM SYSTEM

The foam pump on each float tank is not serviceable and cannot be overhauled. The float sensor in the 18 gallon tank also is not serviceable. Check lines for leaks and condition. Refer to Air Tractor manual for tank to hopper pump information.

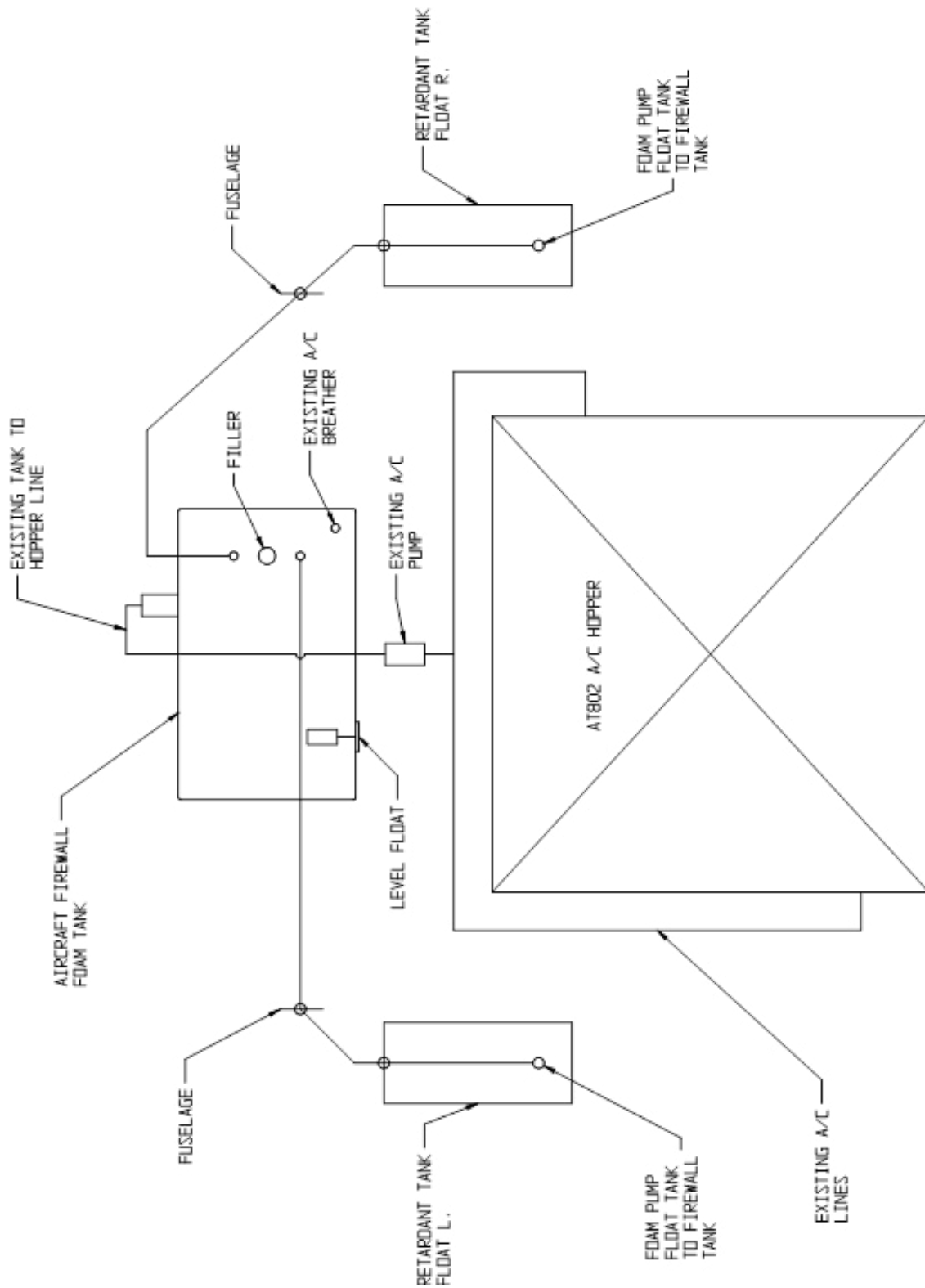

FIGURE 5.1 SCHEMATIC – PLUMBING – FOAM SYSTEM

THIS PAGE INTENTIONALLY LEFT BLANK

CHAPTER 6 FLOAT BILGE SYSTEM OPERATION, REMOVAL, AND SERVICE

CONTENTS

6.1 DESCRIPTION AND OPERATION	60
6.2 ADJUSTMENT AND TEST.....	60
6.3 REMOVAL OF THE SYSTEM.....	60
6.4 SERVICE – BILGE SYSTEM.....	60

CHAPTER 6 - FLOAT BILGE SYSTEM OPERATION, REMOVAL, AND SERVICE

6.1 DESCRIPTION AND OPERATION

Each float is equipped with (2) bilge pumps. These pumps are located in float compartments just forward of the step. These pumps are accessible through the inspection covers on each float side just forward of the step. In the event of leakage of the float hull, adjacent to the probe, these pumps will automatically pump water overboard in that float compartment. Also, in that float compartment, a water sensor indicator is located. When this indicator senses water, a light on the auxiliary instrument panel will light.

6.2 ADJUSTMENT AND TEST

No adjustment is necessary for this system. When pumps are operating. A light for the right float and left float will illuminate on the auxiliary instrument panel. When water is present in the float compartment forward of the step, the sensor will illuminate a light on the auxiliary instrument panel.

6.3 REMOVAL OF THE SYSTEM

To remove pumps from the float, remove access covers on each float side just forward of the step and remove pumps. Two pumps are located in each float.

6.4 SERVICE – BILGE SYSTEM

The bilge pumps are not serviceable and cannot be overhauled. Be sure pumps are not plugged and free of debris. Check all hoses for obstructions and condition. Check that the pump on lights are working. Submerge water sensor in water to check for light operation.

CHAPTER 7 VENT AND OVERFILL PROTECTION SYSTEM

CONTENTS

7.1 DESCRIPTION AND OPERATION	62
7.2 ADJUSTMENT AND TEST.....	62
7.3 SERVICE OVERFILL VENT SYSTEM.....	62

CHAPTER 7 - VENT AND OVERFILL PROTECTION SYSTEM

7.1 DESCRIPTION AND OPERATION

On the top aircraft hopper door, aft side, is a domed shaped overfill relief door. This door is hinged and spring loaded to blow open in the event of a tank overfill. The spring tension is pre-set by cable length. To open the door by hand, release the handle from its holder and pull forward to release the stop from its holder and let the cable go slack. The door is now free to hinge. To reattach, pull cable forward so cable ball is in its holder and stow handle.

7.2 ADJUSTMENT AND TEST

No adjustment is necessary for this system. The cable lengths determine the pressure on the spring. It should unseat at approximately 40 pounds of force.

7.3 SERVICE OVERFILL VENT SYSTEM

No service is necessary except to examine the condition of the cables, canvas defector, and all other parts.

CHAPTER 8 FLOAT STEERING AND RETRACT SYSTEM

CONTENTS

8.1 DESCRIPTION AND OPERATION	64
8.2 ADJUSTMENT	64
8.3 REMOVAL AND ACCESS	64
8.4 SERVICE OF STEERING AND RETRACT SYSTEM.....	64

CHAPTER 8 - FLOAT STEERING AND RETRACT SYSTEM

8.1 DESCRIPTION AND OPERATION

The water rudder retract system is manually operated by a lever in the cockpit. The water rudder is then operated by a system of cables and pulleys. Steering is directed from the aircraft steering system. See Figure 8 for retract and steering schematic.

8.2 ADJUSTMENT

Rigging of the water rudder steering cables is accomplished by centering the aircraft rudder and adjusting the turnbuckles such that both rudders trail with the float centerline. Set steering and balance cable tension to 10 lbs +5/-0. Retraction cables should be rigged such that the rudder blade is in the up position and that the cables are just slack in the down position and lightly resting on the stops.

8.3 REMOVAL AND ACCESS

Cables can be accessed through the fuselage side panels, aft trailing edge of pylon, and through top float inspection covers.

8.4 SERVICE OF STEERING AND RETRACT SYSTEM

The pulley bearing on both systems are sealed and not serviceable. Inspect condition of all pulleys and cables for wear every 100 hours and replace as necessary.

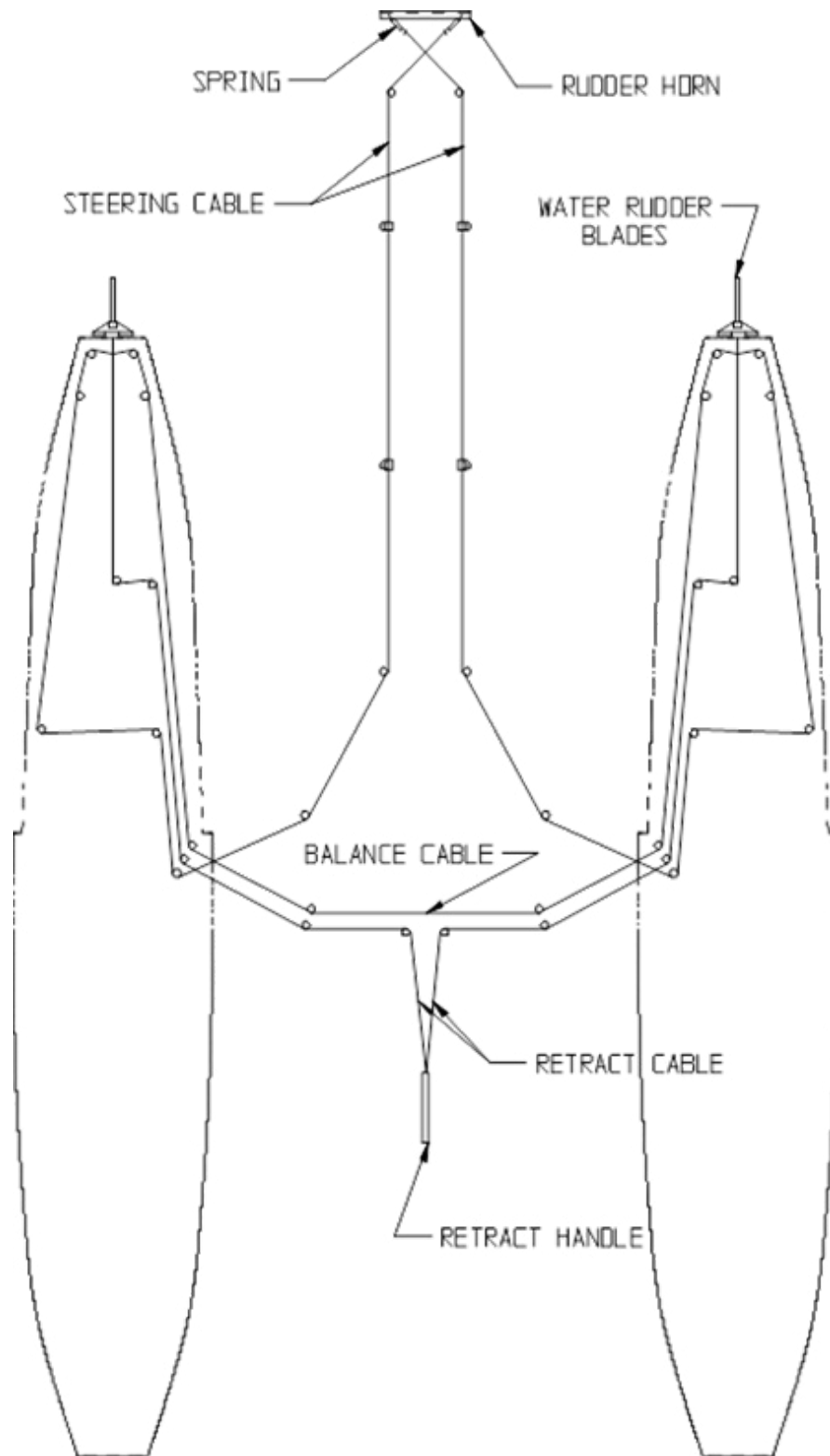

FIGURE 8.1 WATER RUDDER STEERING AND RETRACTION SYSTEM

THIS PAGE INTENTIONALLY LEFT BLANK

CHAPTER 9 ANGLE OF ATTACK SYSTEM

CONTENTS

9.1 GENERAL	68
9.2 MAINTENANCE	68

CHAPTER 9 – ANGLE OF ATTACK SYSTEM

9.1 GENERAL

The Rite Angle 111b AOA system is installed in this aircraft. A separate manual is provided for installation and operation of this system. This system is not a primary aircraft instrument and is for advisory only.

9.2 MAINTENANCE

The AOA system is pre-programmed for the AT-802A aircraft on 10000 floats. The wiring schematic is on figure 9.4. The manual for all other instructions is in the manufacturer's manual.

The vane setting should be 7.8 ° nose up from aircraft leveling point when 1st green light just comes on. Measurements were taken from flat section of vane. Figure 9.4A shows resistances in ohms (Ω) across the P-12 connection on the J6 module box. These readings are approximates only and vary from installation to installation, however they provide a good reference for different flap settings in ensuring the flap sensor is calibrated.

CHAPTER 10 AIRCRAFT WING AND CONTROL SURFACE MODIFICATIONS

CONTENTS

10.1 DESCRIPTION AND OPERATION	70
10.2 MAINTENANCE	70

CHAPTER 10 - AIRCRAFT WING AND CONTROL SURFACE MODIFICATIONS

10.1 DESCRIPTION AND OPERATION

The wing leading edge and the leading edge of the horizontal stabilizers have vortex generators installed. Each wing leading edge has 63 generators and each horizontal stabilizer has 21 generators. If one falls off, replace it according to the drawing instructions.

The horizontal stabilizer is modified for installation of vertical finlets. Each stabilizer has 2 finlets, one on the topside and one on the lower side, a total of 4 per aircraft.

The elevator servo tab has been modified to add 1.0 inch to the cord of the tab.

10.2 MAINTENANCE

VORTEX GENERATORS:

Inspect wings and horizontal tail for missing vortex generators. No two adjacent generators may be missing on any wing or horizontal stabilizer. Any missing generators must be replaced as soon as possible.

FINLETS:

(50 hrs) – Perform a visual inspection of auxiliary finlets and struts, if installed. Clean the area; inspect auxiliary finlet installation for missing gaskets and loose bolts or cracks in attach fittings; if struts are installed, inspect the strut and attach fittings for loose bolts or cracks; inspect the area of the stabilizer around mounting holes and doublers for cracks or loose rivets.

It is acceptable to remove small portions of the finlet side skins or sealant adjacent to the attach fittings to enable visual inspection of the fitting up to the weld fillet.

REMOVE AND INSPECT (100hrs) – Remove the lower finlet and strut, if installed, to expose access panel. Either remove panel and inspect forward and aft attach points as well as spar corner radius for cracks and corrosion or remove hole plug and use borescope for same. Remove upper finlet and strut, if installed. Inspect all finlets, struts and attach fittings for cracks, corrosion, loose rivets, or other un-airworthy conditions.

MISC:

Inspect elevator servo tab extension for condition and security.

CHAPTER 11 AUXILIARY INSTRUMENT PANEL

CONTENTS

11.1 DESCRIPTION AND OPERATION72

CHAPTER 11 - AUXILIARY INSTRUMENT PANEL

11.1 DESCRIPTION AND OPERATION

An auxiliary instrument is mounted on top of the landplane instrument panel. This panel houses all the switches, lights, and displays for the water scooping portion of this installation.

This panel also houses the ITT and Torque gauges for easier viewing. Figure 11.1 and 11.2 shows the panel layout along with the circuit breaker panel layout.



THIS PANEL FOR AIR TRACTOR
S/N 172 AND LOWER



THIS PANEL FOR AIR TRACTOR
S/N 173 AND UP

FIGURE 11.1 INSTRUMENT PANEL

SERVICE MANUAL & ICA
 10000 AMPHIBIAN FLOATS ON AIR TRACTOR AT-802A

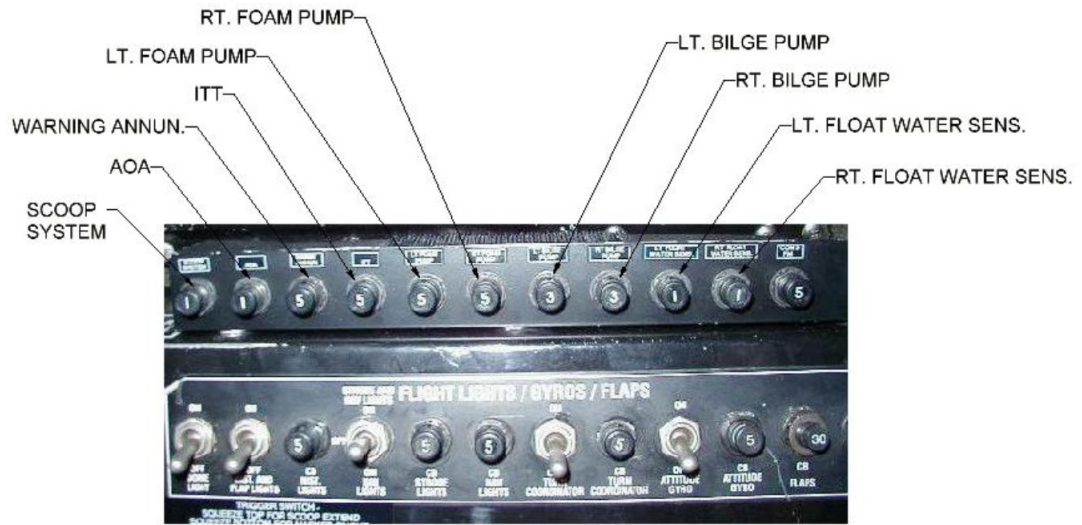

FIGURE 11.2 INSTRUMENT PANEL (CIRCUIT BREAKER)

THIS PAGE INTENTIONALLY LEFT BLANK

CHAPTER 12 ELECTRICAL

CONTENTS

12.1 GENERAL	76
--------------------	----

CHAPTER 12 - ELECTRICAL

12.1 GENERAL

Figures 12.1 through figure 12.11 show the electrical schematic for the auxiliary instrument panel along with electrical schematics for each noted system.

SCHEDULE - PANEL LITES & SWITCHES

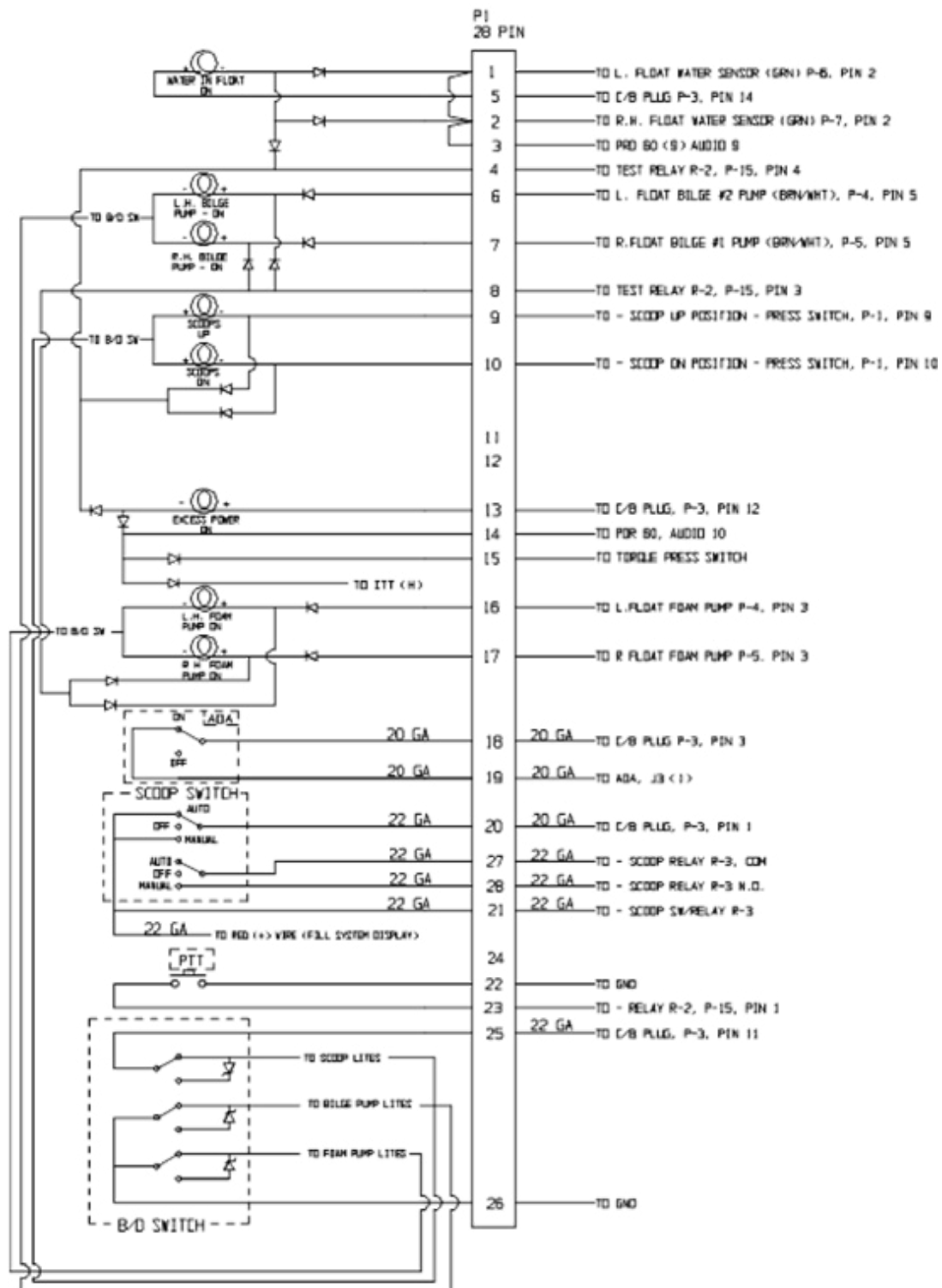

FIGURE 12.1 SCHEMATIC – AUXILIARY INSTRUMENT PANEL

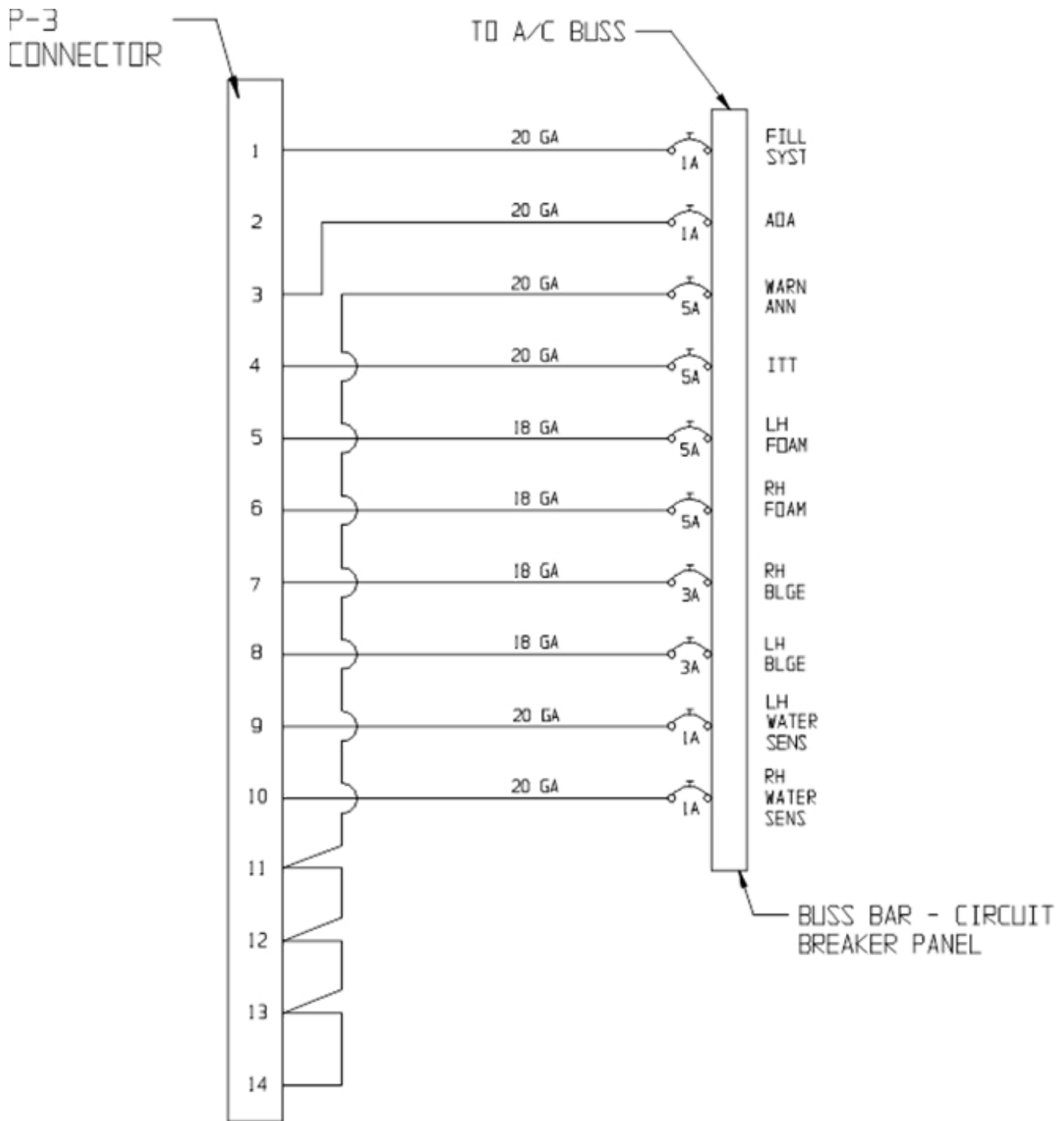

FIGURE 12.2 SCHEMATIC – CIRCUIT BREAKER PANEL

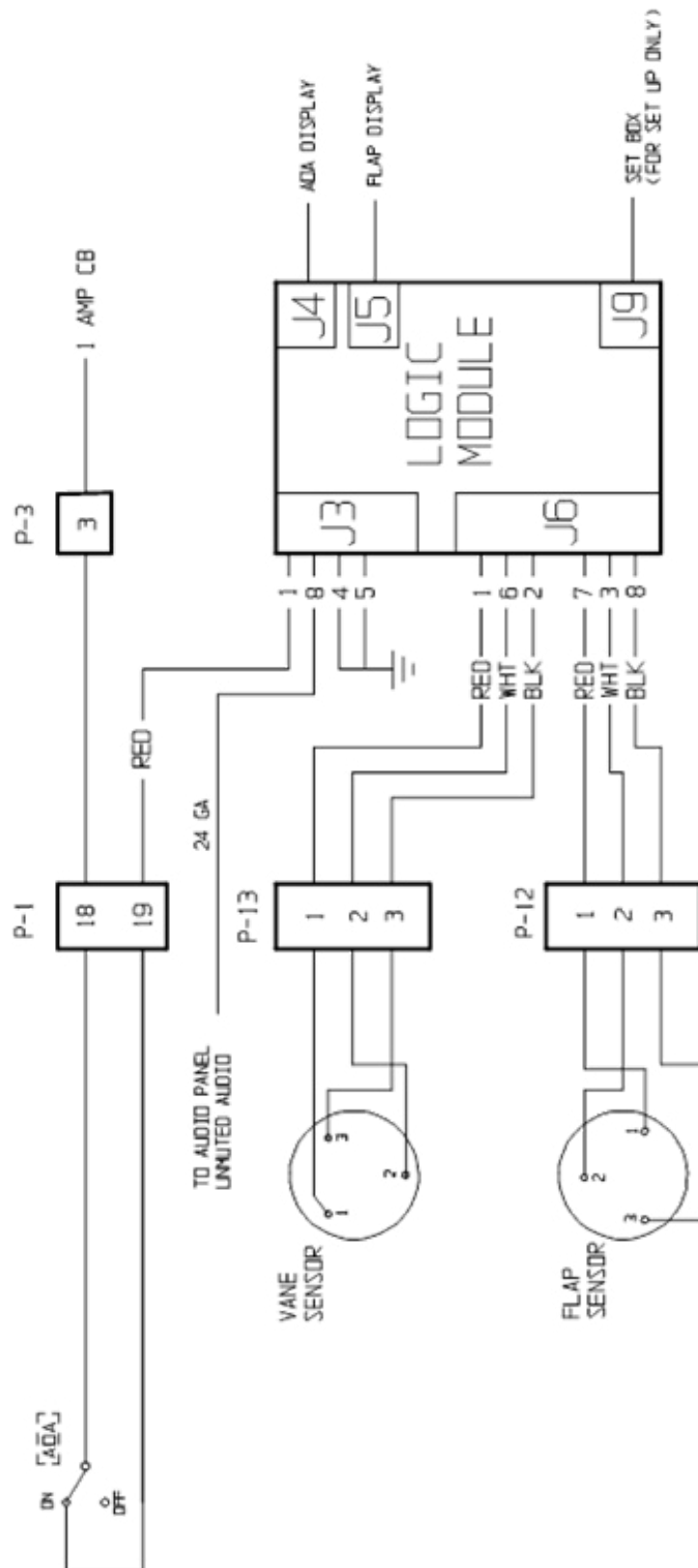
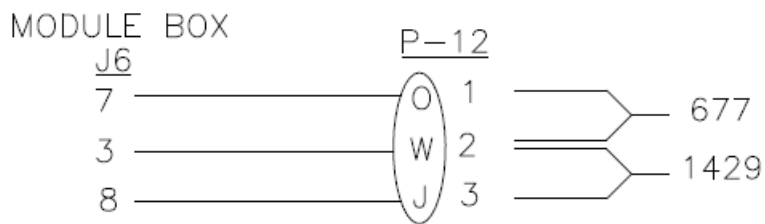
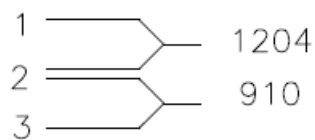

FIGURE 12.3 SCHEMATIC – INSTALLATION – ANGLE OF ATTACK

FLAP SENSOR



FLAPS UP



FLAPS 9.4°

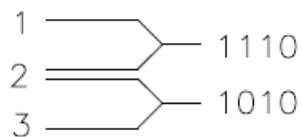

FLAPS 18.6°

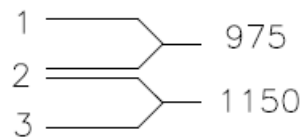

FLAPS 28.4°

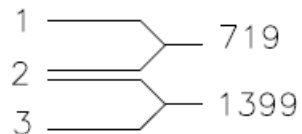

FIGURE 12.4 AOA FLAP CALIBRATION READINGS

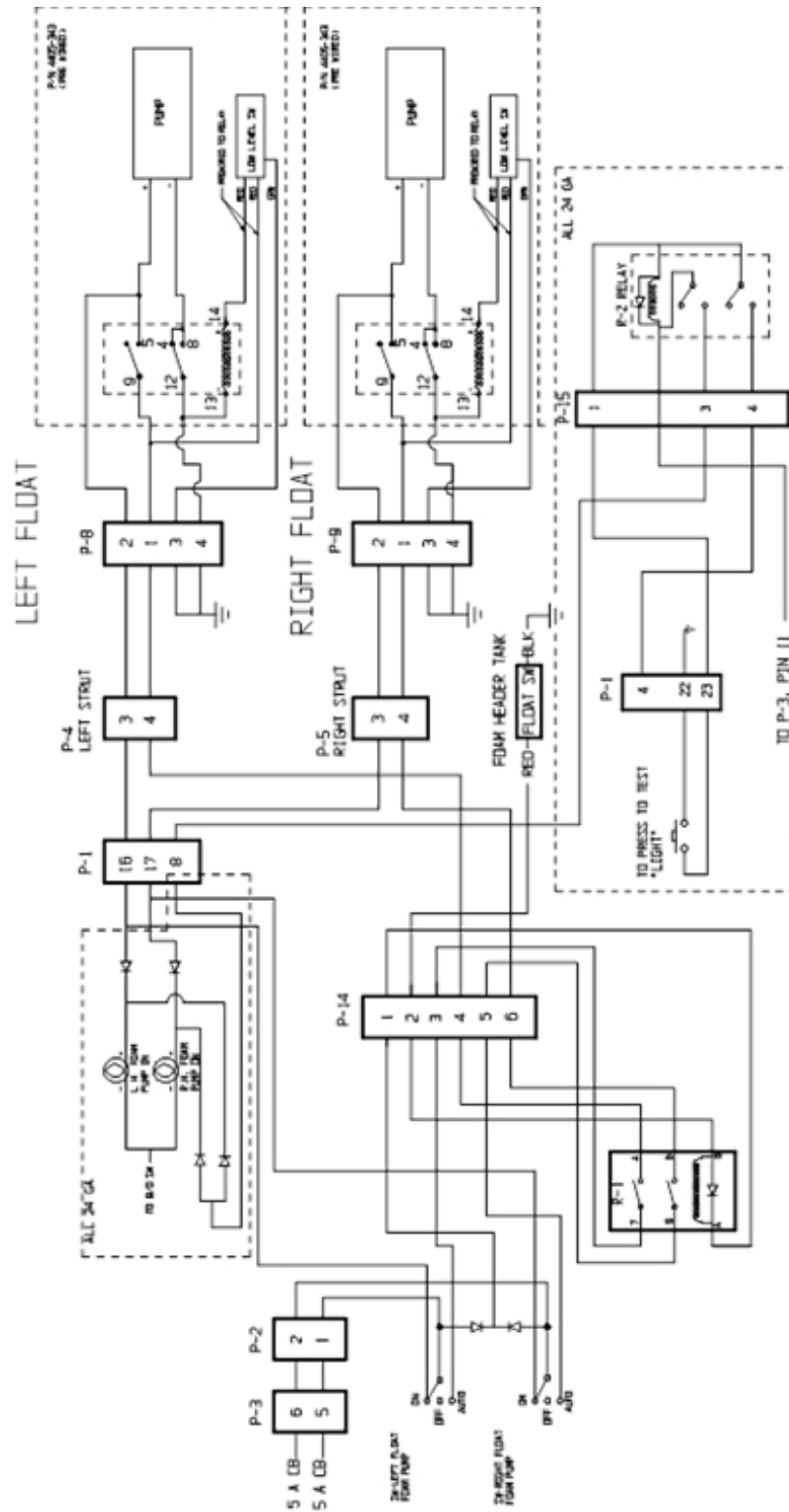

FIGURE 12.5 SCHEMATIC – INSTALLATION – FOAM TANKS/PUMPS

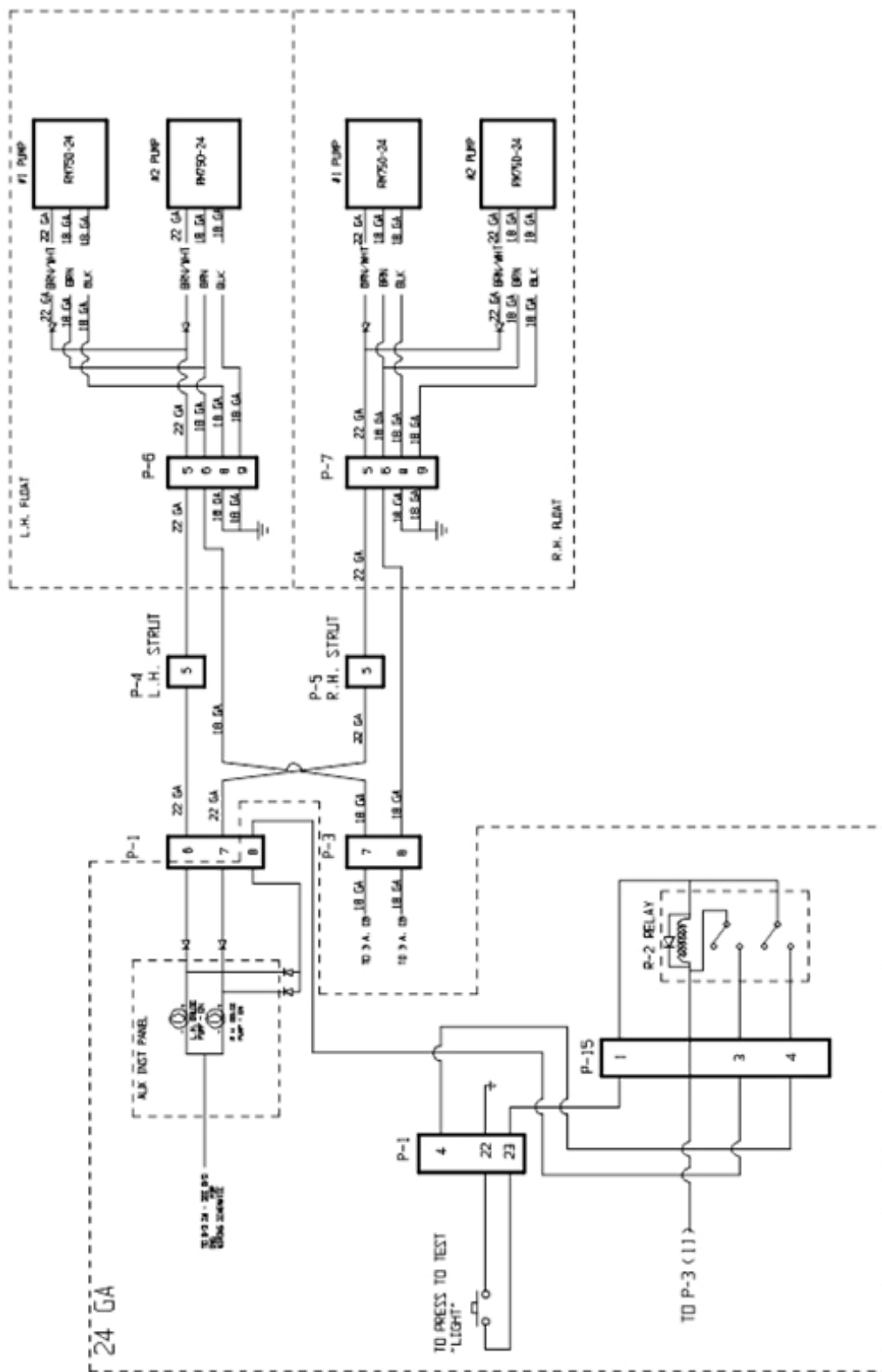

FIGURE 12.6 SCHEMATIC – INSTALLATION – BILGE PUMPS

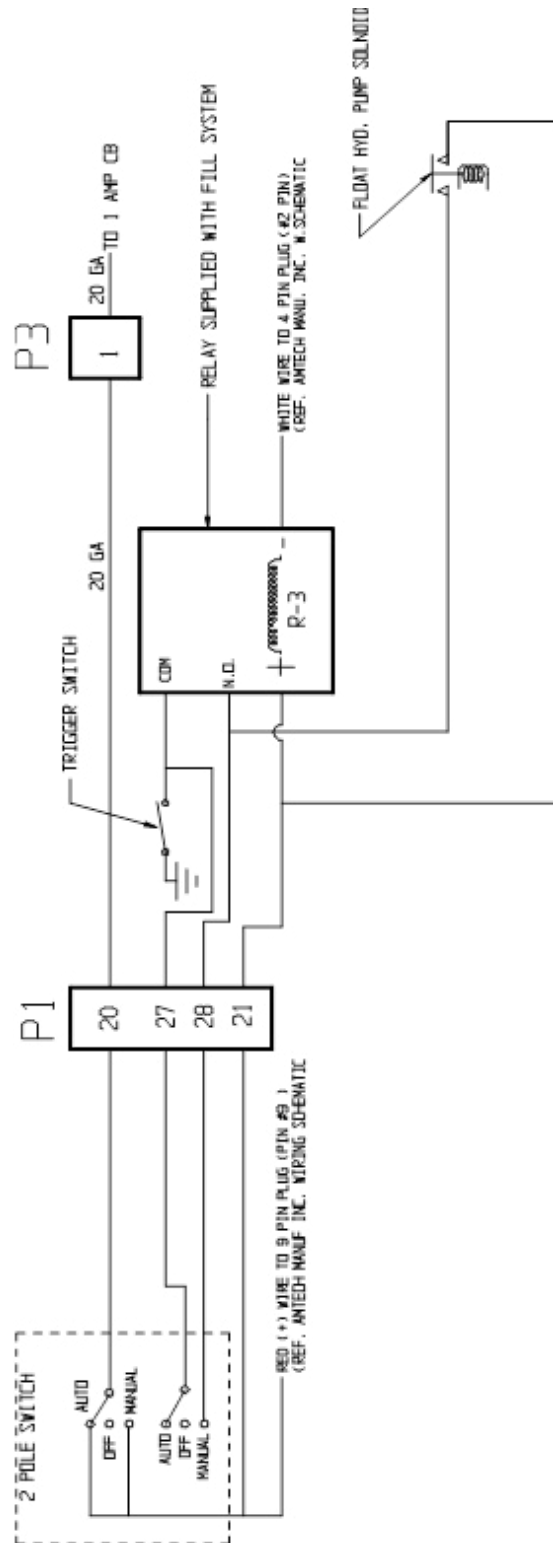

FIGURE 12.7 SCHEMATIC – INSTALLATION – SCOOP/FILL SYSTEM

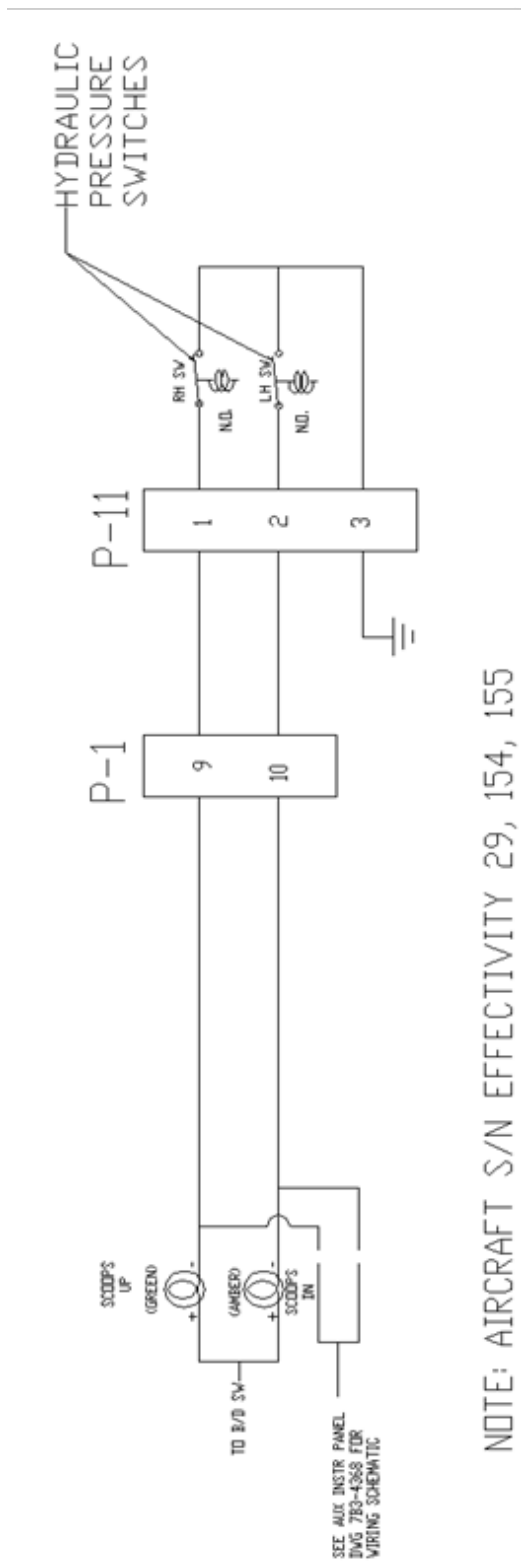

FIGURE 12.8 SCHEMATIC – INSTALLATION – PROBE POSITION

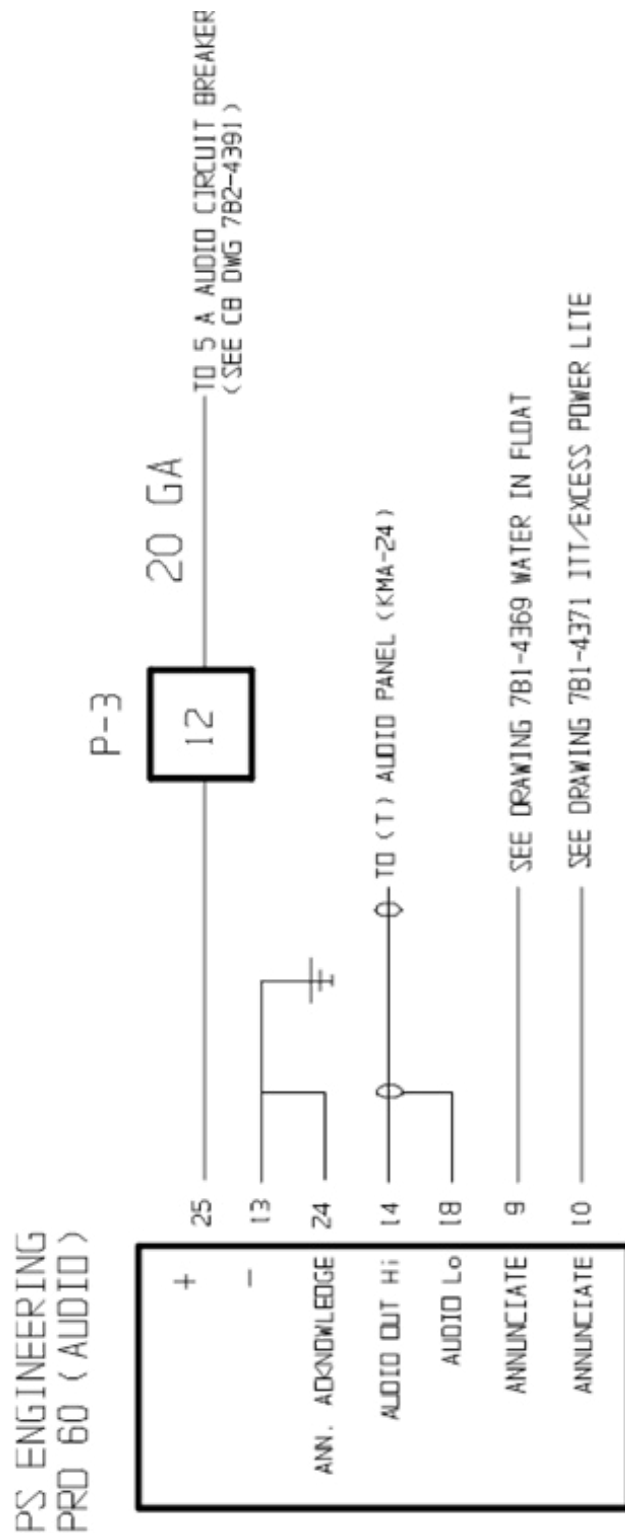

FIGURE 12.9 SCHEMATIC – INSTALLATION – PDR 60 AUDIO

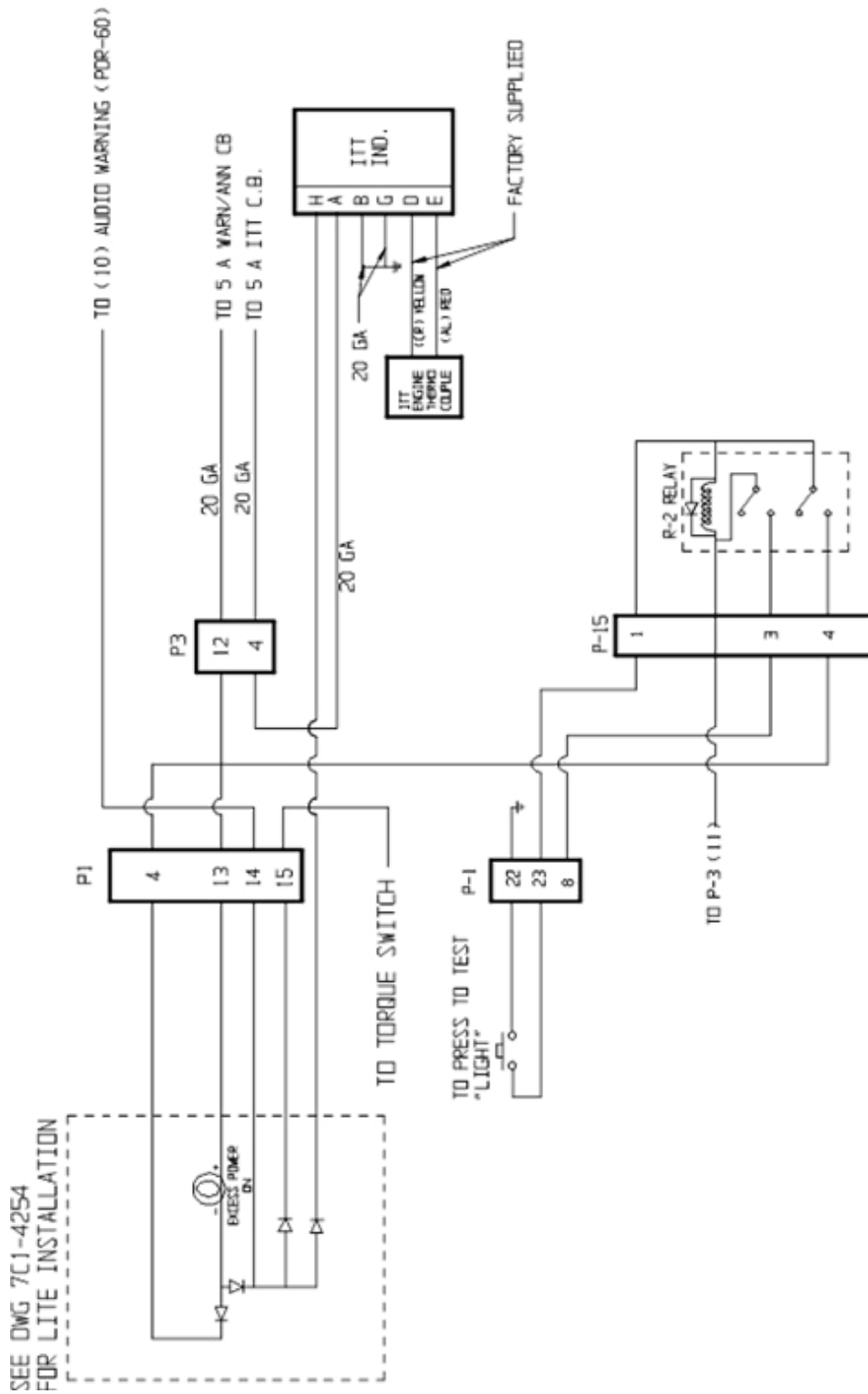

FIGURE 12.10 SCHEMATIC – INSTALLATION – ITT / EXCESS POWER LIGHT

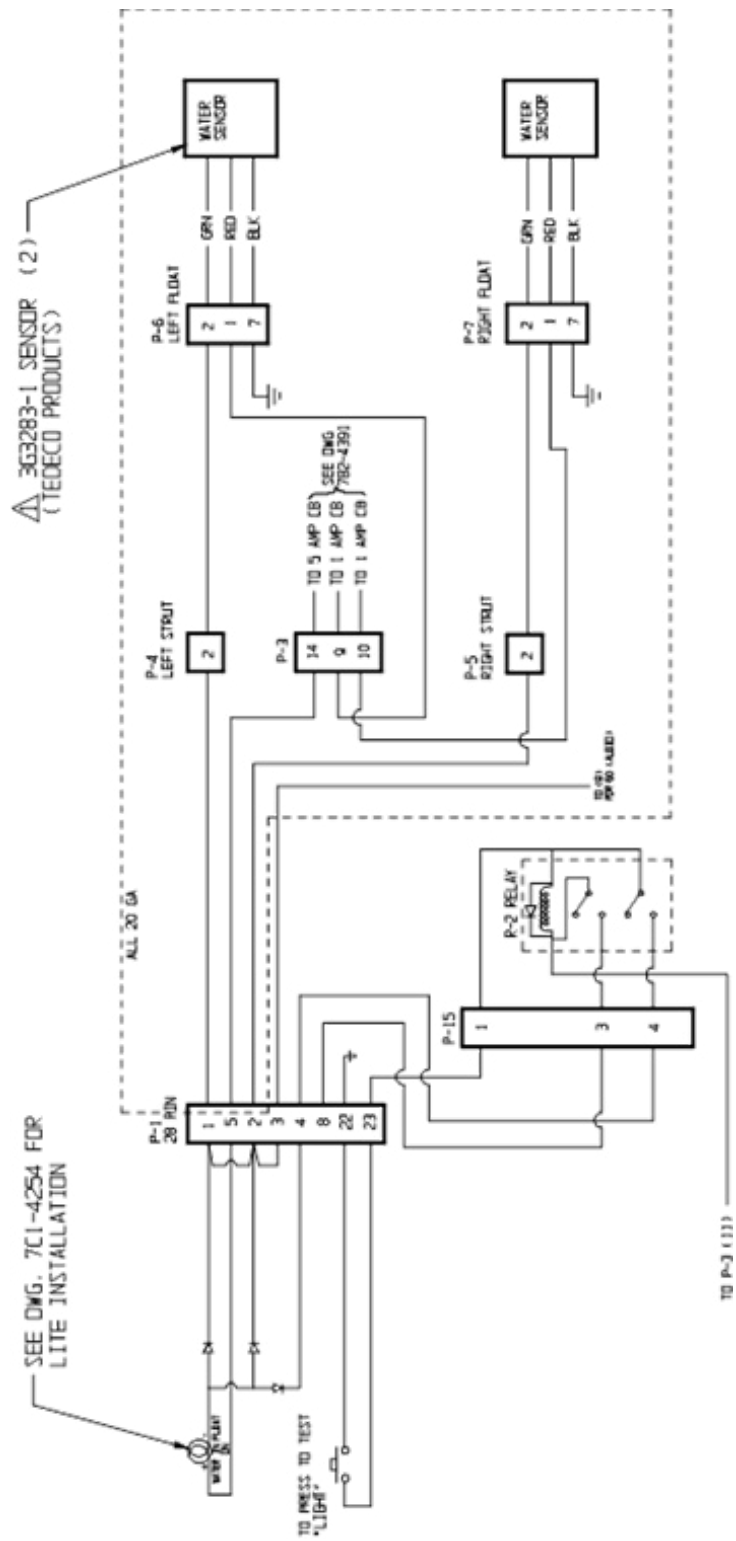

FIGURE 12.11 SCHEMATIC – INSTALLATION – WATER IN FLOAT SENSORS

THIS PAGE INTENTIONALLY LEFT BLANK

CHAPTER 13 REPAIRING FLOAT HULL SHEET METAL, BULKHEADS AND OTHER AREAS

CONTENTS

13.1 GENERAL	90
--------------------	----

CHAPTER 13 - REPAIRING FLOAT HULL SHEET METAL, BULKHEADS AND OTHER AREAS

13.1 GENERAL

For all float skin and extrusion structural repairs, refer to Wipaire's Structural Repair Manual (SRM) part number 1008274.

CHAPTER 14 CONTINUED AIRWORTHINESS

CONTENTS

14.1 SERVICE SCHEDULE	92
14.2 FLOAT HARDWARE RECOMMENDED RETORQUE AND REPLACEMENT CHECKLIST	97

CHAPTER 14 - CONTINUED AIRWORTHINESS

14.1 SERVICE SCHEDULE

As coded in the Inspection Time Intervals chart in this section, there are items to be checked each 25, 50, 100 hours and annual. Also there are notes on special items which may require servicing at more frequent intervals.

- When conducting an inspection at 25 hours, all items marked for 25 hours would be accomplished.
- When conducting an inspection at 50 hours, the 25 and 50-hour items would be accomplished.
- When conducting an inspection at 100 hours, the 25, 50, and 100-hour items would be accomplished.
- When conducting an Annual inspection, the 25, 50, 100, and Annual items would be accomplished.

Below is a list of recommended lubricants and “protection” products when servicing float hull, amphibious components, and firebombing equipment. This lists products used by Wipaire during assembly of the floats.

There may be equivalent products just as satisfactory for protection. However, it is recommended if trying different products, to inspect them frequently so as to determine their effectiveness.

Protection of nuts, bolts, hydraulic lines or metal surfaces

Dinitrol AV30 - Dinol Group

CRC – SP400 Soft Seal - CRC Industries

General Lubricants

LPS 1, LPS 2 and LPS 3 - LPS Industries

Wheel Bearings

*HCF Grease, P/N 605 - HCF Industries

*Aeroshell 22 - Shell Global Solutions

*Green Grease, Multi-Purpose - Green Grease Inc.

*Aviation Grease SHC 100 - ExxonMobil Aviation Lubricants

*Aeroshell 64 (For Nose Pivot Block Only)

Rust Protection

Boeshield T9 Rut Protection - Boeing Company

ACF-50 Rust Protection

Tef-Gel - Ultra Safety Systems, Inc.

Corrosion X - Corrosion Technologies Corporation

Float Sealant

890 B2 or B4 - Pro Seal Company

PR 1440 C - PPG Aerospace

1422 B2, B4 or B6 - Pro Seal Company

RTV Silicones - General Electric

SIKAFLEX 201 or 252 - Sika Manufacturing

Electrical Insulating Compound

Dow Corning 4 (DC4) - Dow Corning Corporation

Hydraulic Fluid

Mil-H-5606

Brake Caliper Grease

STA-Lube

* If existing grease cannot be identified you must lubri-flush all float grease fittings until visibly exhausting all old grease and new grease is coming out. Additionally if you cannot determine existing grease in wheel bearings, completely clean and repack bearings with new grease.

As general inspection guidelines, each of the following areas should be inspected for their own unique attributes:

Movable Parts

For lubrication, servicing, security of attachment, binding, excessive wear, safetying, proper operation, proper adjustment, correct travel, cracked fittings, security of hinges, defective bearings, cleanliness, corrosion, deformation, sealing, and tension.

Fluid Lines and Hoses

For leaks, cracks, dents, kinks, chafing, security, corrosion, and deterioration.

Metal Parts

For security of attachment, cracks, metal distortion, broken welds, corrosion, condition of paint, and any other apparent damage.

Wiring

For security, chafing, burning, defective insulation, loose or broken terminals, corroded terminals.

Bolts in Critical Area

For corrosion, correct torque when installed, or when visual inspection indicates a need for a torque check.

Nut torque should be applied depending on the hardware application, unless the torque is specified for a certain

joint in this manual or installation drawings.

Reference checklist in Section 14.2 for specific hardware recommended torque and replacement.

****TENSION APPLICATION**

Nut-Bolt Size	Torque Limits In-lbs Minimum	Torque Limits In-lbs Maximum
8-36	12	15
10-32	20	25
1/4-28	50	70
5/16-24	100	140
3/8-24	160	190
7/16-20	450	500
1/2-20	480	690
9/16-18	800	1,000
5/8-18	1,100	1,300
3/4-16	2,300	2,500
7/8-14	2,500	3,000
1-14	3,700	4,500
1 1/8-12	5,000	7,000
1 1/4-12	9,000	11,000

****SHEAR APPLICATION**

Nut-Bolt Size	Torque Limits In-lbs Minimum	Torque Limits In-lbs Maximum
8-36	7	9
10-32	12	15
1/4-28	30	40
5/16-24	60	85
3/8-24	95	110
7/16-20	270	300
1/2-20	290	410
9/16-18	480	600
5/8-18	600	780
3/4-16	1,300	1,500
7/8-14	1,500	1,800
1-14	2,200	3,300
1 1/8-12	3,000	4,200
1 1/4-12	5,400	6,600

**A Torque of 80% should be used when Tef-Gel is applied to the bolt.

Some additional general maintenance areas are as follows:

Nose and Main Gear Tracks

Clean and lubricate with grease.

Joints

Spray all joints with light penetrating oil such as LPS 3 to ensure lubrication at all times.

Electrical Connections

Apply SP-400 SOFT SEAL or LPS 500 to all electrical connections to prevent corrosion.

Hydraulic Fluid

For use in all hydraulic systems, including brakes: MIL-H-5606.

THIS PAGE INTENTIONALLY LEFT BLANK

14.2 FLOAT HARDWARE RECOMMENDED RETORQUE AND REPLACEMENT CHECKLIST FOR 10000A FLOATS

See next page for checklist.

Notes:

1. Recommended **RETORQUE** of all items below: **100 hrs +/- 25 hrs**
2. Recommended **REPLACEMENT** of all items below: **750 hrs +/- 250 hrs**
3. Inspection signoff is optional
4. Torque values shown are for clean non lubricated parts. Threads should be free of dust, metal filings, etc.
5. Tef-Gel is recommended to be applied to the bolt shank. Torque values should be reduced by 20% if Tef-Gel is coating the bolt threads.
6. May have 11/16" nut

Item	Bolt Location	Bolt Part Number	Bolt Qty Per Aircraft	Bolt Diameter	Wrench Size	Bolt Torque See Note 4	80% Bolt Torque (Installed with Tef-Gel) See Note 5	Washer Part Number	Washer Qty Per Aircraft	Nuts	Inspection Signoff
1	Fwd strut- Landing gear stub to upper strut fitting	AN10-65A	2	5/8"	15/16"	55 ft-lbs	44 ft-lbs	NAS1149F1063P	4	MS21044N10	
2	Fwd strut- Upper strut fitting to strut assembly	AN10-32A	2	5/8"	15/16"	55 ft-lbs	44 ft-lbs	NAS1149F1063P	4	MS21044N10	
3	Fwd strut- Upper strut fitting through bolts	AN5-36A AN5-33A	4 4	5/16" 5/16"	1/2" 1/2"	6 ft-lbs 6 ft-lbs	5 ft-lbs 5 ft-lbs	NAS1149F0563P NAS1149F0532P	8 8	MS21044N5 MS21044N5	
4	Fwd strut- Lower strut fitting through bolts	AN5-33A AN25-52A	6 2	5/16" 5/16"	1/2" 1/2" (slotted head)	6 ft-lbs 6 ft-lbs	5 ft-lbs 5 ft-lbs	NAS1149F0532P NAS1149F0532P	12 2	MS21044N5	
5	Fwd strut- Lower strut fitting to internal float fitting	AN10-30A	2	5/8"	15/16"	55 ft-lbs	44 ft-lbs	NAS1149F1063P	4	MS21044N10	
6	Fwd spreader bar- Internal float fitting to spreader bar fitting	AN10-30A	2	5/8"	15/16"	55 ft-lbs	44 ft-lbs	NAS1149F1063P	4	MS21044N10	
7	Fwd spreader bar- Spreader bar fitting/tow lug through bolts	AN5-40A	8	5/16"	1/2"	6 ft-lbs	5 ft-lbs	NAS1149F0563P	16	MS21044N5	
8	Center bolt flywires to fwd kicker struts	AN10-37A	1	5/8"	15/16"	55 ft-lbs	44 ft-lbs	NAS1149F1063P	2	MS21044N10	
9	Fwd kicker struts to upper kicker strut mount/saddle	AN7-26A AN7-32A	2 2	7/16" 7/16"	5/8" (Note 6) 5/8" (Note 6)	41 ft-lbs 41 ft-lbs	33 ft-lbs 33 ft-lbs	NAS1149F0763P NAS1149F0763P	4 6	MS21044N7 MS21044N7	
10	Main pylon- Upper rear fuselage fitting to top of pylon	AN12-36A	2	3/4"	1 1/16"	110 ft-lbs	88 ft-lbs	NAS1149F1232P	2	MS21044N12	
11	Main pylon- Fwd bolt through topdeck	AN10-25A	2	5/8"	15/16"	105 ft-lbs	84 ft-lbs	NAS1149F1063P	2	13A02458-005	
12	Main pylon- Aft bolt through topdeck (S.L.182)	MS20008-15	2	1/2"	3/8" Allen Head 5/8" 12 pt nut	75 ft-lbs	60 ft-lbs	MS20002C8 MS20002-8	2 2	NAS1805-8	
13	Main pylon- Inboard pylon to internal float fitting	AN8-32A	2	1/2"	3/4"	30 ft-lbs	24 ft-lbs	NAS1149F0863P	4	MS21044N8	

SERVICE MANUAL & ICA
10000 AMPHIBIAN FLOATS ON AIR TRACTOR AT-802A

Item	Bolt Location	Bolt Part Number	Bolt Qty Per Aircraft	Bolt Diameter	Wrench Size	Bolt Torque See Note 4	80% Bolt Torque (Installed with Tef-Gel) See Note 5	Washer Part Number	Washer Qty Per Aircraft	Nuts	Inspection Signoff
14	Rear spreader bar- Internal float fitting to aft spreader bar fitting	AN10-31A	2	5/8"	15/16"	55 ft-lbs	44 ft-lbs	NAS1149F1063P	4	MS21044N10	
15	Rear spreader bar- Spreader bar fitting through bolts	AN6-34A	8	3/8"	9/16"	8 ft-lbs	6 ft-lbs	NAS1149D0616J	16	MS21044N6	
16	Rear spreader bar- Center spreader bar fitting to rear kicker struts	NAS6209-29	2	9/16"	7/8"	45 ft-lbs	36 ft-lbs	NAS1149F0932P	2	MS21083N9	
17	Upper rear fuselage fitting to rear kicker struts	NAS6209-26	2	9/16"	7/8"	45 ft-lbs	36 ft-lbs	NAS1149F0932P	2	MS21083N9	
18	Nose gear spring- Upper spring bolts to trolley	AN8-33A AN7-31A	4 4	1/2" 7/16"	1/2" 5/8" (Note 6)	57 ft-lbs 41 ft-lbs	46 ft-lbs 33 ft-lbs	NAS1149F0863P NAS1149F0832P NAS1149F0763P NAS1149F0732P	2 2 2 2	MS21044N8 MS21044N7	
19	Nose gear spring- Lower spring bolts to pivot block	AN7-24A	8	7/16"	5/8" (Note 6)	41 ft-lbs	33 ft-lbs	NAS1149F0732P NAS1149F0763P	4 4	MS21044N7	
20	Nose gear pivot block to nose fork leg	AN7-43A	4	7/16"	5/8" (Note 6)	41 ft-lbs	33 ft-lbs	NAS1149F0732P NAS1149F0763P	4 4	MS21044N7	
21	All Finlet attach bolts	NAS624-8 or NAS6604-8	16	1/4"	5/16"	5 ft-lbs	4 ft-lbs	MS20002C4	16	N/A	

THIS PAGE INTENTIONALLY LEFT BLANK

CHAPTER 15 INSPECTION CHECKLISTS

CONTENTS

15.1 INSPECTION TIME CHECKLIST	102
15.2 OVERGROSS LANDING INSPECTION CHECKLIST	106

15.1 INSPECTION TIME CHECKLIST

Items denoted with () are considered preventative maintenance checks and can be completed and signed off by authorized personnel I.A.W. CFR 14 Part 43.3 and 43.7 and Appendix A subpart C, or equivalent CAA regulation

INSPECTION TIME INTERVALS		HOURLY LIMITS				MECHANIC		
	General	Details	25	50	100	Annual	RT.	LT.
General	Placards					X		
Hulls & Struts	Float Installation.	Float exterior – Inspect for damage, wrinkled metal, corrosion, paint loss, etc.		X*				
		Struts & attach fittings			X			
		Spreader bars			X			
		Float Structure (interior)				X		
	Retorque aft pylon drag strut bolt per Service Letter 182				X			
	Foam Compartment Covers and Seals – Inspect for condition, security operation, and excessive wear.				X			
	Pumper Tube Installation – Inspect for condition, security, routing of hoses.					X		
Water Rudder System	Water Rudder Hinges – Inspect freedom of rotation.					X*		
	Water Rudder Steering and Retract Systems – Inspect the following: cables for broken wire; cable fittings for cable slippage, cracks and distortion.	Inspect cable pulleys for freedom of rotation, cable guard pins for presence; rigging. Retract for operations check.				X		
	Water Rudder Blades and Posts – Inspect for damage, security of attachment, corrosion, paint, rigging.	Inspect water rudder bulkhead boots for cracks and wear.				X		
Electrical System Gear and Probe	Pump and Indicator Light Wiring – Inspect for chafing, broken or loose terminals and general condition.					X		
	Solenoids – Inspect wiring, mounting and general condition.					X		
	Pressure Switches – Inspect wiring, mounting and general condition.					X		

INSPECTION TIME INTERVALS		HOURLY LIMITS					MECHANIC	
	General	Details	25	50	100	Annual	RT.	LT.
	All Pump Motors – Inspect wiring, mounting and general condition.				X			
Landing Gear Systems	Lubricate Nose Gear Tracks.		X*					
	Nose Gear Box/Block Tracks measured at slide route for wear, .050 inches or less wear tolerance.					X		
	Nose Gear Pivot Blocks and Forks – Inspect for condition, lubrication, corrosion and paint.		X*					
	Nose and Main Wheel Bearing – Grease zerk fittings.		X*					
	Hydraulic Fluid Level			X*				
	Wheels and Tires – Inspect for wear, pressure, condition.			X*				
	Brake Assemblies – Inspect for wear, corrosion, leakage.			X*				
	Hydraulic Fluid Screen inside Hydraulic Reservoir – Clean and inspect. Note: If floats sit for extended periods of time (i.e., if removed during winter months), screen should be cleaned before putting floats back into service.	Hydraulic fluid in reservoir should be checked for moisture or other contaminants and changed if necessary.				X		
	<ul style="list-style-type: none"> • (3) External Hydraulic 10 micron filter elements – Clean and inspect, replace if needed. • Replace spin on filter. Note: If floats sit for extended periods of time (i.e., if removed during winter months), screen should be cleaned before putting floats back into service.	Hydraulic fluid in reservoir should be checked for moisture or other contaminants and changed if necessary.				X		
	If equipped, inspect spin on filter bypass flag. If popped, remove and clean or replace all filters.		X*					

INSPECTION TIME INTERVALS		HOURLY LIMITS				MECHANIC		
	General	Details	25	50	100	Annual	RT.	LT.
	Main and Nose Gear Actuator, Assemblies – Inspect for condition, lubrication, leakage, corrosion and cleanliness.	NOTE: Follow revised directions in Service Letter #80 for operations from sand and gravel.			X			
	Nose Gear Springs – Scotchply springs, inspect for cracks, delamination and paint. Recommended replacement at 2500 flight hours.	See Figure 14.1 at the end of this spreadsheet. If cracks extend lower than the nose spring upper plate P/N 13A07212-002: Remove the nose-spring and inspect holes. Replace nose spring if any one crack exceeds 1.5" long or if any two cracks protruding from one hole exceed 1.25" in total length.			X			
	Retorque Nose Gear Spring, attach hardware.	Reference Tension Application Torque Chart			X			
	Main Gear Drag Link – Inspect for condition, lubrication, corrosion, check attach bolts for wear.	Grease the pivot points.			X			
	Main Gear Shock Strut – Inspect for evidence of corrosion, pitting, cleanliness and security. Check lower attach bolt for wear and lubrication.			X*				
	Main Landing Gear Lower Attach Bolt – inspect for wear and lubrication					X		
	Hydraulic Lines and Fittings – Inspect for leaks, condition and security.					X		
	Hydraulic Manifolds - Inspect for condition, security and leaks.					X		
	Hydraulic Pump – Inspect hydraulic pump, accumulator assembly and Vickers valve for leaks, condition, and security.	Check Hydraulic selector head and hand pump for leaks, condition and security. Instrument Panel press 2 test bulbs.			X			
	Brake System Plumbing – Inspect for leaks, condition and security.					X		

INSPECTION TIME INTERVALS		HOURLY LIMITS					MECHANIC	
	General	Details	25	50	100	Annual	RT.	LT.
		Nose Gear Trolley – Inspect for proper travel				X		
		Nose Gear – Inspect for excessive side play in the down position.				X		
		Perform emergency gear Extension (hand pump).				X		
	Nose and Main Wheel Bearings – Disassemble and inspect.					X		
Fuselage Frame	Inspect fuselage frame tubing and float attaching parts for any signs of bending or weld cracking.	Inspect in the areas of front float strut and the main float pylon attach.				X		
	Comply with Service Letter 170.			X				
Water Pickup Probes	Perform Retraction Test	For probe down position, inspect for proper seating and alignment of tubes.			X			
		Inspect for speed of retraction (approximately one second)			X			
		Inspect for any leaks in probe jack cylinder			X			
		Inspect float area around probe opening for any damage.	X*					
		Inspect scoop probe for damage, confirm welds show no cracks			X			
Auxiliary Finlets	Remove and inspect per Section 10.2				X			
	Visual Inspection per Section 10.2			X*				
	Main Gear Oleos – Service					X		
	Perform Retraction Test	Main Gear – Inspect up and down for proper engagement.				X		

15.2 OVERGROSS LANDING INSPECTION CHECKLIST

REQUIRED IN INSPECTION			MECHANIC	
			RT.	LT.
Landing Gear Systems				
Nose Landing Gear	Nose Wheels – Inspect for wear, damage, and loose attaching hardware to include axle	Loose attaching hardware will require further inspection for deformation and hole elongation		
	Nose Tires – Inspect for wear, pressure, and condition	See Servicing Section in Maintenance Manual for proper nose tire pressure		
	Nose Wheel bearings – Inspect for bearing and seal damage			
	Nose Springs – Inspect for cracks around attaching hardware, material delamination			
	Pivot Block and Nose Forks – Inspect for bending, cracks, loose hardware	Loose attaching hardware will require further inspection for deformation and hole elongation		
	Nose gear Trolley – Inspect for evidence of impact damage near attach points, and all attached linkages to include over center down lock mechanism to include trolley block and/or trolley axles	When damage is found accomplish gear swing, looking for nose gear binding due to component damage and replace as needed.		
	Nose gear ram Assy. and Rod End – Inspect for evidence of damage and proper functionality	See Service Manual for how to properly perform retraction/extension test		
Main Landing Gear	Main Wheels – Inspect for wear, damage, and loose attaching hardware to include axle	Loose attaching hardware will require further inspection for deformation and hole elongation		
	Main Tires – Inspect for wear, pressure, and condition	See Servicing Section in Maintenance Manual for proper nose tire pressure		
	Main Wheel Bearings - Inspect for bearing and seal damage			
	Drag link, Tube, and Axle Assy. – Inspect for damage, attach point failure, loose/sheared hardware			

REQUIRED IN INSPECTION			MECHANIC	
			RT.	LT.
Main Landing Gear Continued	Main Gear Trunnion attach – Inspect for damage, loose hardware, and surrounding bulkhead attach point for damage			
	Main Landing Gear Shock Strut – Inspect attach points for wear, cracking, hardware failure -- Check Shock Strut servicing for proper pressure			
	Brake Assemblies – Inspect brake linings and calipers for evidence of over temp, wear, and leaking			
Main Gear Retraction	Inspect main gear attach point for damage and loose/sheared hardware	Loose attaching hardware will require further inspection for deformation and hole elongation		
	Inspect Carriage for evidence of damage and proper functionality	See Service Manual for how to properly perform retraction/extension test		
	Inspect Slide Tube attach points for damage and loose/sheared hardware to include Slide Tube concentricity			
Float Hulls	Inspect float exterior for evidence of wrinkled metal, smoking rivets, and popped fasteners			
	Inspect keel for any evidence of contact with runway			
	Inspect float compartment bulkheads for deformation, buckling, and popped fasteners			
	Foam tank system, inspect tanks for cracks, damage, and attach points on tank and float			
	Float Top deck and strut attach points – inspect area for damage to float top deck for evidence wrinkled metal, smoking rivets, and popped fasteners			
Struts/ Spreader Bars	Inspect for wear, damage, and loose attaching hardware	Loose attaching hardware will require further inspection for deformation and hole elongation		

REQUIRED IN INSPECTION			MECHANIC	
			RT.	LT.
Struts/ Spreader Bars Continued	Strut/Spreader Bar fittings – inspect fittings for material stress and cracks on attaching locations			
	Fuselage float fitting attach points – Inspect area for bending, cracking, or distortion			
	Detailed Inspection of all strut attach on bulkheads for signs of fatigue surrounding strut attach points			
	Fwd/Aft kicker strut attach points --Inspect for component distortion, Loose or damaged hardware	Loose attaching hardware will require further inspection for deformation and hole elongation		

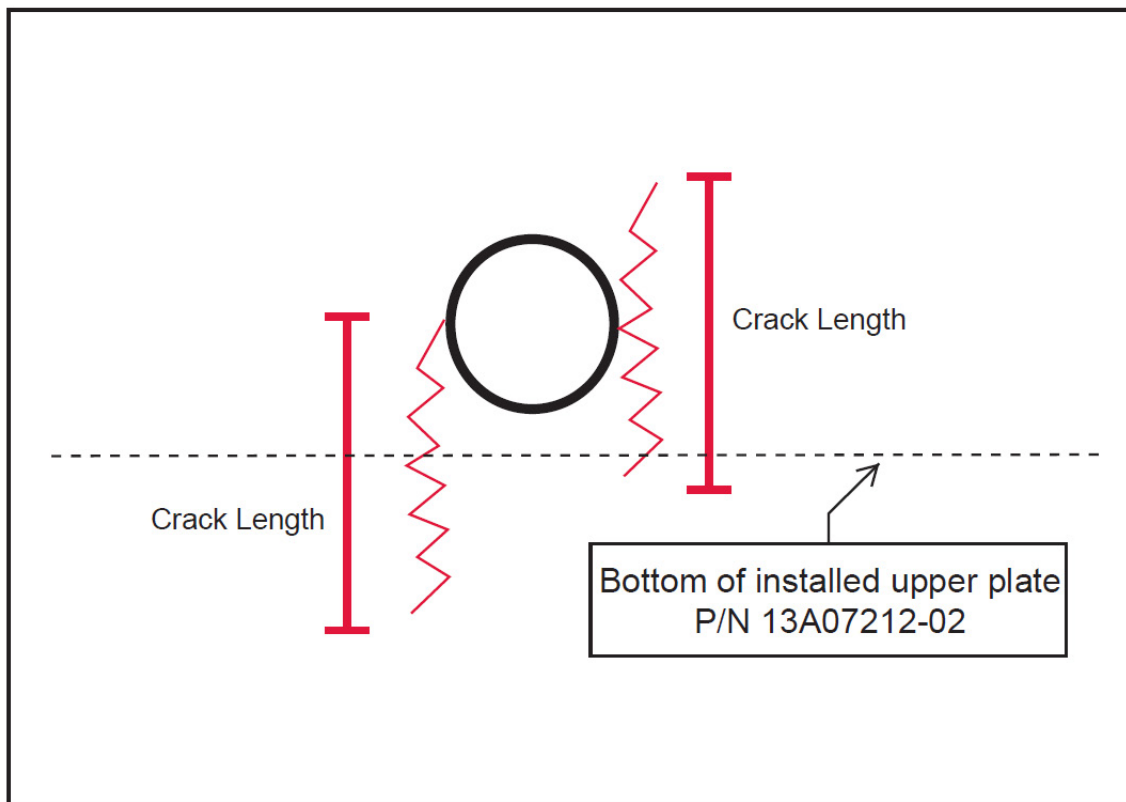

FIGURE 15.1 EXAMPLE NOSE SPRING CRACK MEASUREMENTS (NOT TO SCALE)

CHAPTER 16 WEIGHT AND BALANCE

CONTENTS

16.1 WEIGHING PROCEDURES FOR THE AT-802A FIREBOSS AMPHIBIAN.....	110
--	-----

CHAPTER 16 - WEIGHT AND BALANCE

16.1 WEIGHING PROCEDURES FOR THE AT-802A FIREBOSS AMPHIBIAN

Level aircraft per manufacturer's instructions.

Place scales under the right and left nose and main gear wheels.

Place blocking under right and left main gear wheels to level aircraft.

Drop plumb bob from wing leading edge on either side of the plane to the floor and mark. This is the datum-line, station 0.0.

Draw another line between the nose wheel centers and a 3rd line between the main wheel centers.

Measure the distance from 0.0 to the nose wheel line. This is X.

Measure the distance from 0.0 to the main wheel line. This is Y.

Use this table for the calculations:

Scale Reading	Distance from 0.0		Weight x Arm
	Weight	x Arm	= Moment
Left Front	+	- X	-
Right Front	+	- X	-
Left Rear	+	+ Y	+
Right Rear	+	+ Y	+
Totals			

Notes: 1. Zero out or deduct tare weights at the Y arm.