



SERVICE LETTER NUMBER 128			
TITLE: MAIN LANDING GEAR (MLG) GRAVEL DEFLECTOR INSTALLATION			
BY: J. SORTOR	AIRCRAFT MAKE/MODEL(S):	FLOAT MODEL(S):	NOTE(S):
APP: D. GARRETT	Quest Aircraft Design, LLC		OPTIONAL COMPLIANCE
DATE: 5/7/2013	Kodiak 100,	7000	S/L P/N 1005612
REV: C	Cessna 208 Caravan	8750	ECO 23243

FAA APPROVAL HAS BEEN OBTAINED FOR TECHNICAL DATA IN THIS PUBLICATION THAT AFFECTS STC OR TSO DESIGN COMPLIANCE

EFFECTIVITY:

This service letter applies to all S/Ns Wipline model 7000 amphibian floats, as installed on Quest Aircraft Design, LLC Kodiak 100 aircraft per FAA STC number SA02848CH, and all S/N's Wipline Model 8750 Amphibian floats, as installed on Cessna Aircraft, 208 Caravan per FAA STC number SA1311GL.

COMPLIANCE:

Service letter compliance is optional and recommended for aircraft operating on gravel runways.

BACKGROUND:

Aircraft operated on gravel runways may experience rock impact damage to the MLG main beam, forward surface and brake bleeder fittings. This service letter and associated kit reinforces the surface forward surface of the MLG main beam by adding a layer of stainless steel skin, which is attached with fasteners and sealant.

COMPLIANCE METHOD:

Install the parts included in this service letter in accordance with the instructions in the Technical Data section of this service letter.

APPROX. SHOP HOURS:

This service letter will take approximately 1 labor hours for complete.

WARRANTY INFORMATION:

Parts and labor warranty is not included for this modification.

TECHNICAL DATA:

Copies of this service letter, associated service kit, float service manual, modification drawing, and float parts manual are available on the website www.wipaire.com.

See service kit number 83 for a list of parts and materials applicable to this modification.

For basic model 7000 maintenance information, see Wipaire Service Manual P/N 1004646.

For basic model 7000 parts information, see Wipaire Parts Manual P/N 1005250.

For basic model 8750 maintenance information, see Wipaire Service Manual P/N 1005723.

For basic model 8750 parts information, see Wipaire Parts Manual P/N 1005812.

To accomplish this modification: follow the instructions on Wipaire drawing 1005488. Be sure to liberally apply sealant and also not allow the excess sealant to fall elsewhere on the MLG. Be sure the sealant layer between the SS sheet and aluminum landing gear machining has complete coverage. The modification may be performed with or without the MLG installed in the hull. If the modification is performed “in hull,” ensure no sealant drips on brake calipers.

KIT CONTENTS:

The following parts are included in this service kit. Parts quantity shown is for one MLG only. Two kits will be required for each aircraft.

Parts List			
ITEM	QTY	PART NUMBER	DESCRIPTION
1	3	NAS1149F0432P	WASHER
2	1	PR-1422-B-2	SEALER
3	1	1005443	GRAVEL DEFLECTOR
4	2	MS21044N4	NUTS

Sealer compound above is provided, and may be optionally replaced with Pro-Seal P/N 890-B2 or -B4 or Sikaflex P/N 201 or 252, or equivalent.



WIPLINE FLOATS • SKIS • MODIFICATIONS • AIRCRAFT SALES
AVIONICS • INTERIOR • MAINTENANCE • PAINT REFINISHING

SERVICE LETTER 128
PAGE 3 of 3 REV: C

NOTES:

After completion of the instructions in this service letter, make an entry as such in the aircraft logbook in accordance with your local Civil Aviation regulations. Wipaire considers the weight and balance change to be negligible for this modification.

END

REVISION HISTORY			
REV	DATE	ECO	DR
A	11/07/11	Z2955	SSJ
A	03/14/12	Z2727	SSJ

DESCRIPTION	
INITIAL RELEASE	
NAS1149F0432P WAS NAS1149F1290P	

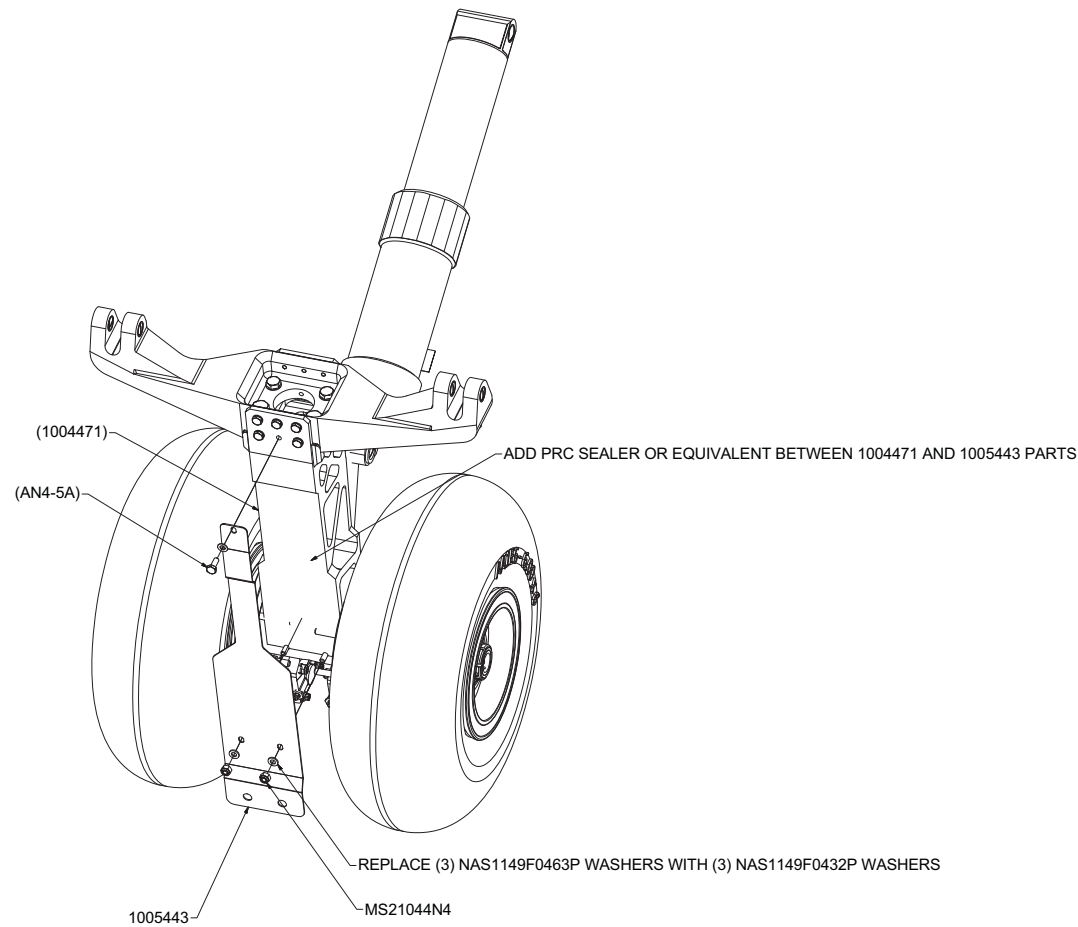

- NOTES:**
1. REMOVE (1) AN4-5A BOLT AND (1) NAS1149F0463P WASHER AS SHOWN.
 2. REMOVE (2) MS21044N4 NUTS AND (2) NAS1149F0463P WASHERS AS SHOWN.
 3. INSTALL (1) 1005443 USING PR-1422-B-2 SEALER (OR EQUIVALENT) BETWEEN IT AND 1004471. BE SURE TO SPREAD SEALER OVER ENTIRE MATING SURFACE.
 4. RE-INSTALL (1) AN4-5A BOLT WITH A REPLACEMENT WASHER NAS1149F0432P.
 5. INSTALL (2) (NEW) MS21044N4 NUTS WITH (2) REPLACEMENT WASHER NAS1149F0432P.
 6. ADD A FILLET OF SEALER AROUND 1005443.

Parts List			
ITEM	QTY	PART NUMBER	DESCRIPTION
1	3	NAS1149F0432P	WASHER
2	1	PR-1422-B-2	SEALER
3	1	1005443	GRAVEL DEFLECTOR
4	2	MS21044N4	NUTS

MATL	SEE PARTS LIST	WIPAIRE, INC. 1700 HENRY AVE. SOUTH ST. PAUL, MN 55075 (651) 451-1205
FINISH	N/A	
TITLE		INSTALLATION, GRAVEL DEFLECTOR
ALL DIMS IN INCHES & AFTER FINISH	THIRD ANGLE PROJECTION	TOLERANCES .XX" = ±.05 .XX" = ±.015 .XX" = ±.005 X" = ±.5
SIZE	SCALE	PART NO.
D	1/2	1005488
Sheet 1 of 1		REV
		B