



WIPLINE FLOATS | MODIFICATIONS | AIRCRAFT SALES  
AVIONICS | INTERIORS | MAINTENANCE | PAINT



**SERVICE MANUAL  
FOR THE  
WIPLINE MODEL 13000  
AMPHIBIOUS AND SEAPLANE FLOAT  
ON THE  
DHC-6 TWIN OTTER**

**Revision T**

THIS PAGE INTENTIONALLY LEFT BLANK

### LOG OF REVISIONS

Rev	Pages	Description	Date
A	11, 26	Added an inspection time limit and tolerances for the Nose Block Track wear.	4/18/2006
B	13-14, 44, 55	Updated to Maintenance Manual per 23-8. Added 3-view images of floatplane. Added section 4.1 regarding rivet replacement. Added section 4.4 regarding bulkhead holes for maintenance.	11/22/2010
C	All	Reformat of entire document. Add green grease as approved grease.	4/18/2013
D	22, 56, 59	Added Shear Torque Chart, PR 1440 C Sealant and Tef-Gel. Removed Warranty Claim Form. Corrected Oil amount 1900 was 1140.	5/26/2015
E	5, 15, 56, 59	Added Dow Corning DC4, Corrosion X, and Mobil Aviation Grease SHC 100 to approved product list. Modified torque limit section.	12/4/2015
F	8	Added reference for Structural Repair Manual part number 1008274 in introduction.	5/1/2019
G	15, 18, 37, 56	Added information about corrosion limits. Added note about STA-Lube. Updated drawing for Nose Gear Lower End Assembly. Added STA-Lube to Brake Caliper Grease.	8/3/2020
H	All	Reformatted manual in new software. Added sections 1.3 through 1.7. Removed Comet Industries GP-730A. Removed content in Chapter 4 and replaced with note about SRM. Removed Figures 4.1 through 4.10 as content is found in SRM.	2/3/2021
J	25	Updated Shock Strut Servicing instruction step 5 and removed note.	5/26/2022
K	24	Updated instructions in Shock Strut Servicing section.	11/3/2022
L	23	Added note to Section 2.3.	4/6/2023
M	7	Added note to introduction about parts manual.	7/11/2023
N	54	Updated note about Bolts in Critical Areas and torque limit tables in section 5.2.	1/2/2024
P	20, 48, 57- 59, 61-65	Added section 1.9. Updated bolt torque information in Section 5.0 Added section 7. Moved Standard Torque Value tables to section 7.0. Added Appendix A section for float installation and removal.	7/11/2024
R	53	Corrected "reaction" to "retraction" in Landing Gear Systems in the 5.2 Inspection Checklist.	12/20/2024
T	23, 52	Updated Section 2.2 for nose gear tracks to be lubricated with LPS 02616 Dry Lube instead of grease. Added information about slide tube condition to Inspection Checklist in section 5.2.	Pending

View most current revision of this ICA at [www.wipaire.com](http://www.wipaire.com).

THIS PAGE INTENTIONALLY LEFT BLANK

## TABLE OF CONTENTS

INTRODUCTION .....	7
CHAPTER 1 GENERAL INFORMATION .....	11
CHAPTER 2 MAIN AND NOSE GEAR OPERATION, REMOVAL & SERVICE.....	21
CHAPTER 3 HYDRAULIC PUMP SYSTEM, DISASSEMBLY & SERVICE.....	41
CHAPTER 4 REPAIRS .....	45
CHAPTER 5 CONTINUED AIRWORTHINESS .....	47
CHAPTER 6 WEIGHT AND BALANCE .....	55
CHAPTER 7 BOLT TORQUES .....	57
APPENDIX A - FLOAT INSTALLATION AND REMOVAL.....	61

## LIST OF FIGURES

FIGURE 1.1 JACK CRADLE RECOMMENDED MODIFICATION .....	14
FIGURE 1.2 JACKING LOCATION.....	14
FIGURE 1.3 FLOAT SECURING LOCATIONS.....	15
FIGURE 1.4 FLOAT SECURING LOCATIONS OVERVIEW .....	16
FIGURE 2.1 HYDRAULIC SYSTEM SCHEMATIC.....	31
FIGURE 2.2 SCHEMATIC – ELECTRICAL SYSTEM .....	32
FIGURE 2.3 LAYOUT – MAIN GEAR .....	33
FIGURE 2.4 CARRIAGE ASSEMBLY – MAIN GEAR .....	34
FIGURE 2.5 ASSEMBLY – MAIN GEAR SHOCK STRUT .....	35
FIGURE 2.6 ASSEMBLY – MAIN GEAR CYLINDER.....	36
FIGURE 2.7 ASSEMBLY – MAIN GEAR DRAG LINK.....	37
FIGURE 2.8 ASSEMBLY – MAIN GEAR WHEEL AND BRAKE .....	38
FIGURE 2.9 ASSEMBLY – NOSE GEAR BOX AND RETRACTION .....	39
FIGURE 2.10 ASSEMBLY – NOSE GEAR LOWER END .....	40

## INTRODUCTION

This manual is provided for the owners of Wipaire model 13000 Floats as installed on the DHC-6 Twin Otter. It has two main priorities, to inform owners of the level and amount of servicing required to properly maintain their floatplane, and to provide technical data and servicing specifics to maintenance professionals charged with servicing the floats.

When performing standard repairs for Wipline Aluminum Floats, please refer to the “Structural Repair Manual For Wipline Aluminum Floats” part number 1008274. It is available free of charge online at [www.wipaire.com](http://www.wipaire.com).

The service products referred to throughout this manual are described by their trade names and may be purchased from the Wipaire Parts Department.

**Note:** For approved design data parts, reference 13000 float parts manual 1001021 for DeHavilland DHC-6.

We, at Wipaire, thank you for your purchase and look forward to years of satisfying exchanges with you. Your floats are built with pride and attention to detail, but we want that care to extend beyond your purchase.

Our customer service department, WipCaire, is available for your questions 24 hours a day, 7 days a week, wherever you are in the world.

Wipaire, Inc.  
1700 Henry Avenue – Fleming Field  
South St. Paul, MN 55075  
Telephone: (651) 306-0459  
Fax: (651) 306-0666  
Website: [www.wipaire.com](http://www.wipaire.com)  
Email: [CustomerService@wipaire.com](mailto:CustomerService@wipaire.com)

In this service manual we have worked hard to include many repair scenarios in addition to the recommended products, practices, and routine maintenance required to keep your floats in working order.

When a float part is significantly changed or an additional inspection recommended or required, often a service letter and/or kit is issued. If a warranty is issued, most commonly it is for an 18 month time period, so it is crucial to check for service letters specific to your float model at each periodic inspection to be eligible.

Service Manuals and the installation prints included are also revised periodically and also need to be kept updated. Service letters, service kits and Service manuals are available on our website [www.wipaire.com](http://www.wipaire.com) at no charge.

**CHECKING FOR THESE UPDATES SHOULD BE A PART OF ROUTINE MAINTENANCE**

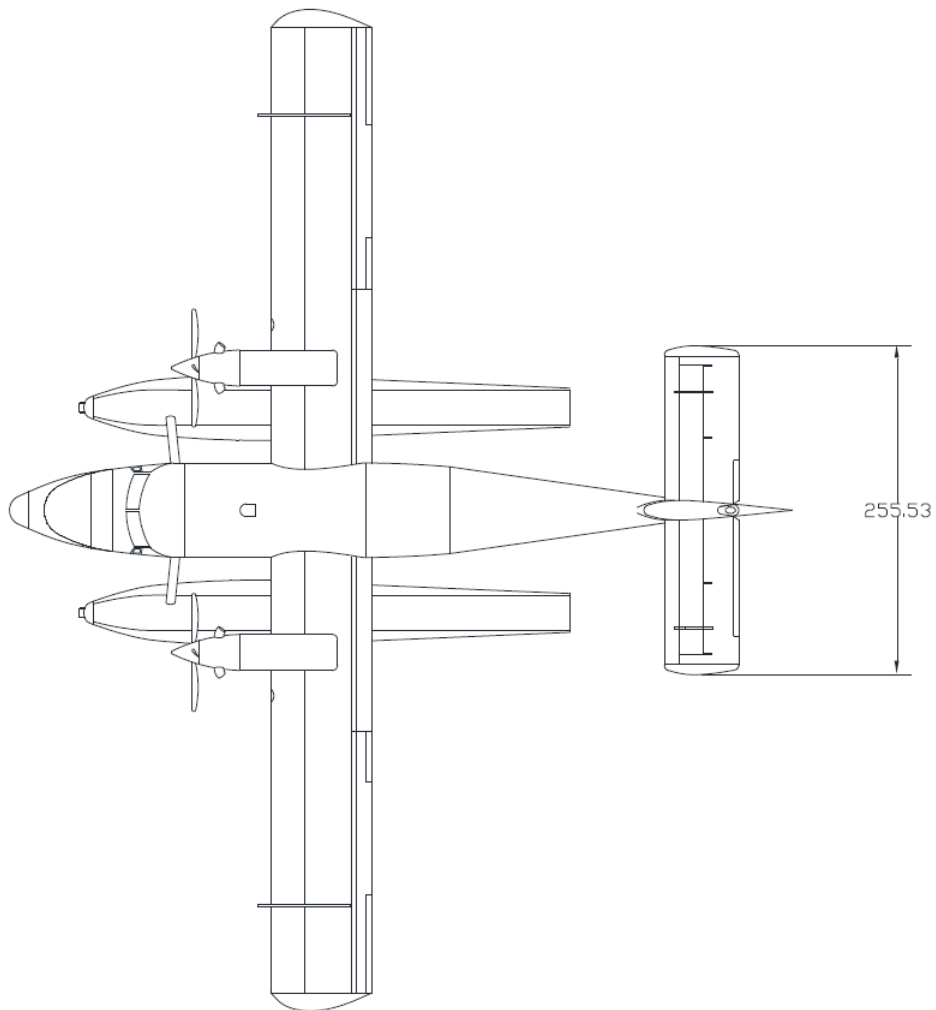
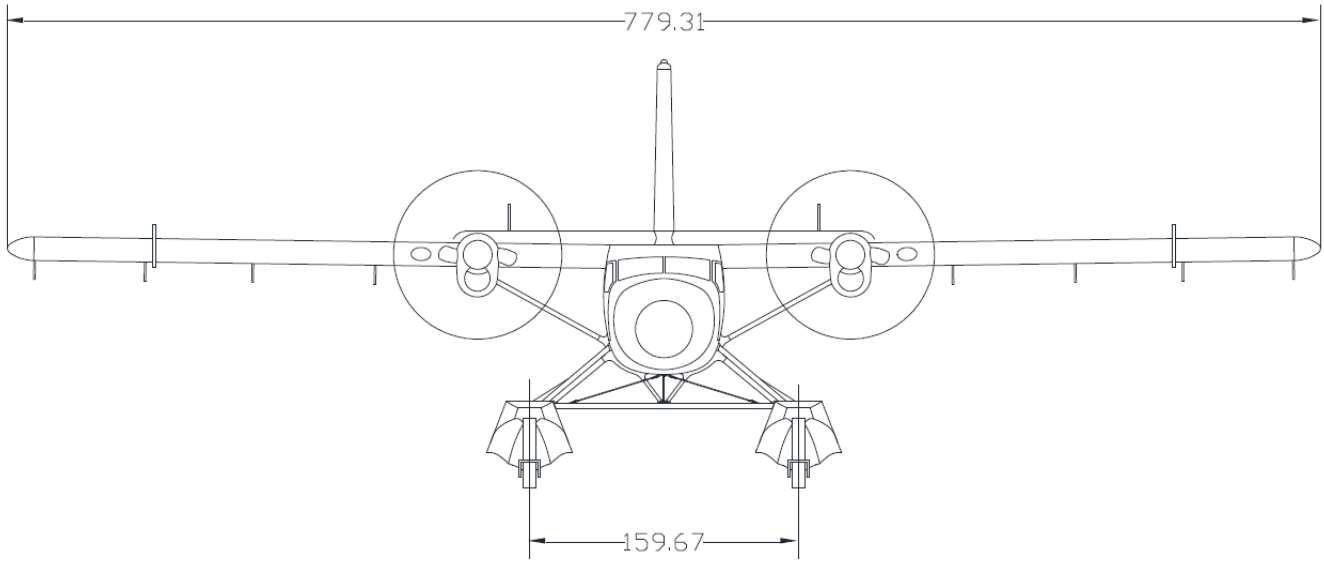

SERVICE MANUAL & ICA  
WIPLINE 13000 FLOATS

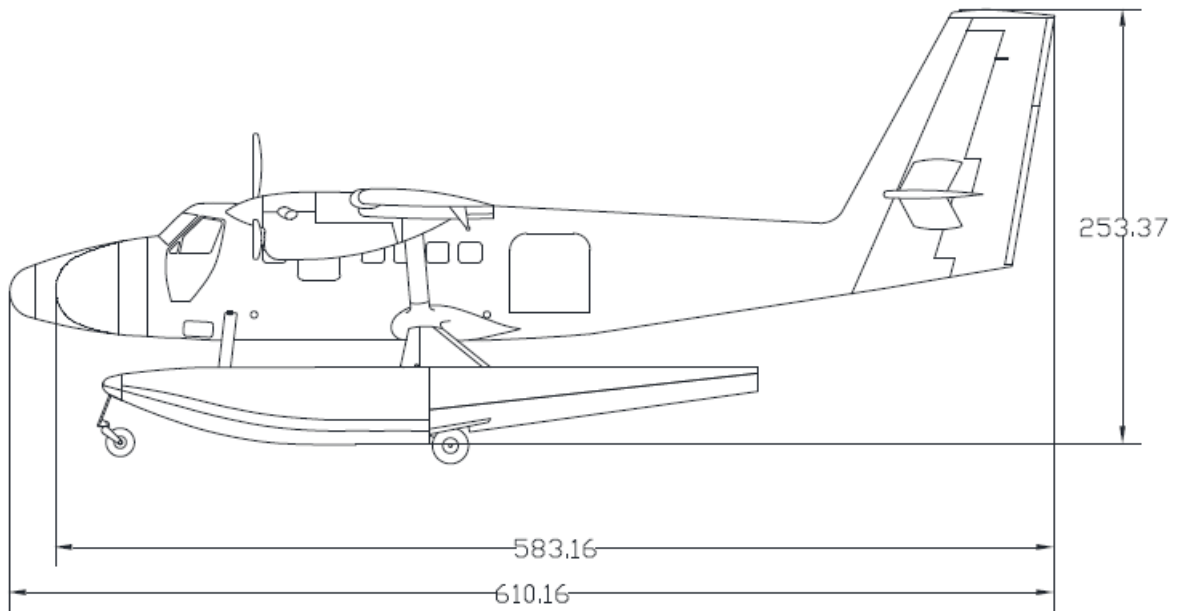

THIS PAGE INTENTIONALLY LEFT BLANK

## CHAPTER 1 GENERAL INFORMATION

### CONTENTS

1.1 AIRPLANE .....	12
1.2 FLOATS .....	12
1.3 TOWING .....	12
1.4 HOISTING .....	13
1.5 LEVELING .....	13
1.6 JACKING PROCEDURES .....	13
1.7 JACK REMOVAL .....	16
1.8 AMPHIBIAN LANDING GEAR SYSTEM .....	16
1.9 INSTALLING AND REMOVING FLOATS .....	20

## 1.1 AIRPLANE

The DHC-6 Twin Otter is a high wing, all metal, twin turbo prop aircraft originally manufactured by de Havilland Canada and currently produced by Viking Air. As part of the float installation the following changes are made to the landplane:

1. The hydraulic landing gear retraction system components and cockpit controls are added\*
2. The landing gear emergency gear operation hand pump and system are added\*
3. Auxiliary Vertical Fins are added

\***Note:** Amphibian float models only

## 1.2 FLOATS

The model 13000 seaplane or amphibious float is an all aluminum-constructed float with watertight compartments. The actual displacement in fresh water for each float is 12844 pounds buoyancy for the seaplane and 12442 pounds buoyancy for the amphibian. The amphibian float is geometrically the same as the seaplane except for the addition of landing gear.

The main landing gear has dual 8:50 x 10 8-ply tires and the nose landing gear has one 6.00 x 6 8-ply tire. The gear system is hydraulically actuated and driven by two hydraulic pumps. Brakes are hydraulic and have a caliper on each main wheel for a total of four brakes.

Steering on land is accomplished by differential braking. The nose wheels are full castering.

Access to the float interior is accomplished by removing covers on the top deck and six covers inside the wheel well. When necessary, water inside the float hulls may be removed through pump-out cups located on the outboard edge of each float top skin.

### FLOAT HULL MAINTENANCE

#### GENERAL

The float structure side, top skins, and bottom skins are 6061-T6 aluminum and extrusions are 6061-T6 aluminum, (keel, chine, etc.). Skins are alodined and primed after being cleaned and acid-etched. Exterior is finished with a urethane color paint or equivalent.

## 1.3 TOWING

When towing the amphibian aircraft, 2 lugs are provided on the lower forward side of the nose spring.

On land, a rigid "V" frame can be fabricated to attach to these lugs for towing the aircraft with a tractor. Lake & Air Training and Pilot Shop has this tow bar available for purchase.



On water, a rope bridle arrangement can be used to tow the aircraft from the lugs described above.

## 1.4 HOISTING

Hoisting the aircraft can be performed using a lifting rig that attaches to the aircraft with lifting rings that are installed at the wing attach points. If the lifting rings are not installed, reference applicable aircraft maintenance/service manual for additional hoisting specifications. Lake & Air Training and Pilot Shop has this hoisting rig available for purchase. Contact Wipaire Customer Service for additional guidance in removal or installation of floats.

### **CAUTION!**

**Make sure nothing is under or above the airplane or floats when hoisting the aircraft**

1. Raise aircraft high enough to place float cradle under floats as shown in Figure 1.4.
2. Lower aircraft onto float cradle as shown in Figure 1.4.
3. Place fore and aft supports as shown in Figure 1.3 and Figure 1.4.

## 1.5 LEVELING

See applicable aircraft maintenance/service manual.

## 1.6 JACKING PROCEDURES

### **CAUTION!**

**Make sure nothing is under or above the airplane or floats when jacking the aircraft.**

1. Turn off fuel.
2. Place weighted bags above the nose gear (approximately 100 lbs. on each float to start, more may be added as needed).
3. Position 1 person at each fore and aft of each float, and 3 people at the jacking location of one float.
4. Modify jack saddle of a 3 ton minimum jack by welding as shown in Figure 1.1.

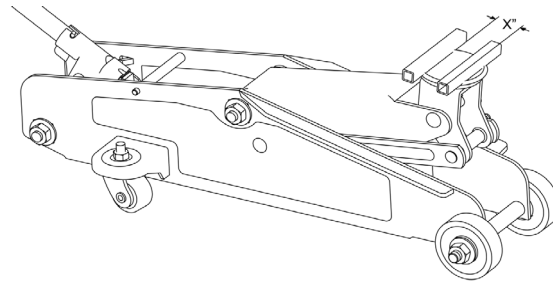

(X = WIDTH OF CRADLE)

### FIGURE 1.1 JACK CRADLE RECOMMENDED MODIFICATION

**NOTE:** This is not required and Wipaire does not have the parts for modification. It is recommended a similar modification be performed to the jack saddle to prevent the slippage of the cradle.

1. Center cradle on saddle and position so cradle is as far aft on the main keel as possible without interfering with main gear as it decompresses as shown in Figure 1.2.

**NOTE:** If desired to prevent possible cosmetic damage to float, use material to separate cradle and float.



### FIGURE 1.2 JACKING LOCATION

1. Jack one side at a time, taking care to check the balance of the aircraft and adding more weight to the front if needed.
2. Two people, both outboard, lift the fore and aft cradle stands up to the cradle as a 3rd person release the pressure slowly, allowing the cradle and stands to gently contact the ground.
3. Repeat previous procedure to the other float.

**NOTE:** A smaller jack may be needed to slightly lift the float into a high enough position for the main jack.

4. Secure floats with fore and aft supports as shown in Figure 1.3 and Figure 1.4.



**FIGURE 1.3 FLOAT SECURING LOCATIONS**



**ALTERNATE JACKING METHOD IF WIPAIRE  
JACKING FIXTURE IS NOT AVAILABLE  
(8000A model shown for reference only)**

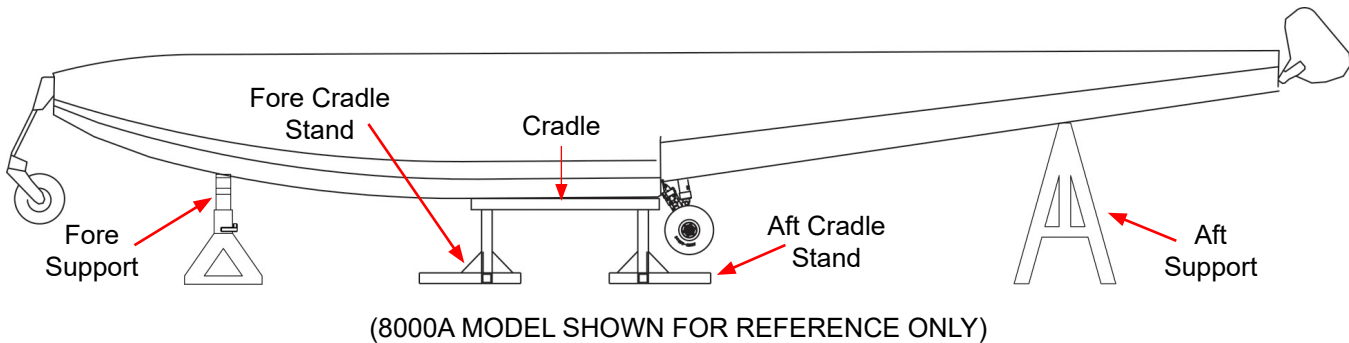

**FIGURE 1.4 FLOAT SECURING LOCATIONS OVERVIEW**

## 1.7 JACK REMOVAL

**Make sure nothing is under or above the airplane or floats when removing the jacks from the aircraft**

1. Turn off fuel.
2. Verify landing gear is in the down and locked position.
3. Verify weighted bags are still located above the nose gear.
4. Position 1 person at each fore and aft of each float, and 1 person at the jacking location of one float.
5. Remove all fore and aft supports as shown in Figure 1.3 and Figure 1.4.
6. Using modified jack saddle as shown in Figure 1.1, center jack saddle in center of cradle on 1 of the floats,
7. Lift aircraft to clear fore and aft cradle stands and remove fore and aft cradle stands of lifted float.
8. Slowly lower float to the ground, remove jack from under float, and remove cradle from jack saddle.
9. Repeat previous procedure to the other float.
10. Remove weighted bags from floats.

## 1.8 AMPHIBIAN LANDING GEAR SYSTEM

The landing gear incorporated within the amphibious floats on this airplane is retractable, quadricycle type with two swiveling nose (or bow) wheels and four (4) (two (2) sets of dual) main wheels. Air-oil shock struts on the two main landing gear assemblies provide shock absorption.

The main landing gear has dual 8:50 x 10 8-ply tires and the nose landing gear has one 6:00 x 6 8-ply tire. The gear system is hydraulically actuated and driven by two hydraulic pumps. Brakes are hydraulic and have a caliper on each main wheel for a total of four brakes.

Steering on land is accomplished by differential braking. The nose wheels are full castering.

Landing gear extension and retraction is accomplished by two (2) electrically-driven hydraulic pumps and four (4) hydraulic actuators (one (1) for each gear). The hydraulic pumps are located in the fuselage nose cone and the hydraulic actuators are located adjacent to each gear. Hydraulic system fluid level should be checked periodically by viewing the sight glass for fluid level in the upper one-third of the range. If fluid is low, fill with MIL-H-5606 or equivalent.

Landing gear operation is initiated by movement of the landing gear handle. When the handle is repositioned, hydraulic pressure in the system will drop and pressure switches will automatically turn on the hydraulic pump motors to maintain operating pressure in the system. When the gear cycle is completed, the pump will automatically shut off. If the pressure in the system drops to a preset value, the pressure switches turn the pump motors back on and build up the pressure to the limit again. Eight (8) position-indicator lights four (4) gear UP and four (4) gear DOWN are provided to show landing gear position. Two (2) additional indicator lights show when the landing gear pump motors are operating.

### **LANDING GEAR HANDLE**

The landing gear handle controls a hydraulic selector valve within the control unit on the left-hand side of cockpit by fuel shut-off handle and has two (2) positions (UP and DOWN LAND) which give a mechanical indication of the gear position selected. From either position, the handle must be pulled out to clear a detent before it can be repositioned.

### **INDICATOR LIGHTS**

Ten (10) indicator lights are mounted on the landing gear control unit adjacent to the landing gear handle. Four (4) blue indicator lights, labeled NOSE and MAIN (left-hand lights for the left float and right-hand lights for the right float), show by their illumination that the landing gear is up and locked. The four (4) green indicator lights, labeled NOSE and MAIN (left-hand lights for the left float and right-hand lights for the right float), are illuminated when the landing gear is down and locked. Neither set of lights is illuminated when the landing gear is in transit. Two (2) red indicator lights, labeled PUMP ON 1 and 2 illuminate when current is supplied to the landing gear motors. If the motors continue running during flight or on and off repeatedly, the motors should be shut off by pulling AMPHIBIAN PUMP 1 AND AMPHIBIAN PUMP 2 circuit breakers. Continual running of the motors can result in premature motor failure. Prior to landing, the circuit breakers should be pushed in to reactivate the circuits. Troubleshoot hydraulic problem per section 3.1.

### **LANDING GEAR OPERATION**

To retract or extend the landing gear, pull out on the landing gear handle and move it to the desired position. When the handle is positioned, pressure on the hydraulic system reduces to where the hydraulic motors automatically turn on. The motors power the hydraulic pumps and actuate the gear actuator for each gear. During operation of the landing gear motors the PUMP ON 1 and 2 indicator lights are illuminated. When the gear cycle is completed, pressure builds up in the hydraulic system and automatically shuts off the hydraulic motors. Each gear operates independently of the other, and therefore, the position lights illuminate at various times.

### **EMERGENCY PUMP HANDLE**

An emergency hand pump is located on the floor to the left side of the seat for use in the event the normal hydraulic system fails. This hand pump may be used to retract or extend the land gear. Prior to utilizing the emergency hand pump, pull the AMPHIB PUMP 1 and 2 circuit breakers to deactivate the electric hydraulic pumps. Select UP and DOWN using the normal landing gear selector handle. Pump the attached handle back and forth (approximately 400 cycles). When a gear reaches the selected position, its indicator light will illuminate. After all four (4) gears are in the selected position there is a noted increase in resistance of hand pump operation.

### **Hard Landing and Damage Investigation**

After a thorough cleaning of the suspected damaged area, all structural parts should be carefully examined to determine the extent of damage. Frequently the force causing the initial damage is transmitted from one member to the next causing strains and distortions. Abnormal stresses incurred by shock or impact forces on a rib, bulkhead or similar structure may be transmitted to the extremity of the structural member, resulting in secondary damage, such as sheared or stretched rivets, elongated bolt holes or canned skins or bulkheads. Points of attachment should be examined carefully for distortion and security of fastenings in the primary and secondary damaged areas at locations beyond the local damage.

### **Cleaning**

The outside of the float should be kept clean by washing with soap and water. Special care should be taken to remove engine exhaust trails, waterline marks, and barnacle deposits. After saltwater operation, washing with fresh water should be done daily with special attention to hard-to-reach places such as: seams, wheel well, etc.

The float interior should be flushed if salt water enters the compartments. If the floats are being stored inside, remove inspection covers so the interior will dry out.

**THE ABOVE CLEANING TECHNIQUES ARE VITAL  
FOR KEEPING CORROSION TO A MINIMUM. SALTWATER  
OPERATIONS AND ENVIRONMENT ARE STRONGLY LINKED TO  
CORROSION AND MUST BE ADDRESSED PROACTIVELY.**

### Corrosion

Reference the Wipaire Structural Repair Manual (SRM) for allowable corrosion/material loss limits. Corrosion is a reaction that destroys metal by an electrochemical action that converts metal to oxide. Corrosion is accelerated when in contact with dissimilar metals such as aluminum and steel, or any material that absorbs moisture like wood, rubber, or dirt.



The primary means of corrosion detection is visual. The most obvious sign is a corrosive deposit of white powder.

Other signs are discoloration of the metal surface or bubbles and blisters under the painted surface. Light corrosion may be removed by light hand sanding or chromic acid. Moderate and severe corrosion (blistering, flaking, and pitting) may be removed by heavy sanding or grinding, and applying chromic acid. If significant loss of skin material thickness will result in corrosion treatment, reinforcement or replacement of the affected area may be necessary.

After removing the corroded area, restore area to original finish (prime and enamel). BOESHIELD T9, Corrosion X, or ACF-50 may also be applied to stop corrosion. Refer to manufacturer's instructions for application instructions.

Maintaining the float inside and outside finishes by washing after saltwater operations will help protect the float from corrosion. Periodically all hardware should be covered with a waterproof grease or Paralketone. Under saltwater conditions, bolts should be removed at least once a year and grease reapplied to the shafts, heads and nuts.

**THE ABOVE CLEANING TECHNIQUES ARE VITAL  
FOR KEEPING CORROSION TO A MINIMUM. SALTWATER  
OPERATIONS AND ENVIRONMENT ARE STRONGLY LINKED TO  
CORROSION AND MUST BE ADDRESSED PROACTIVELY.**

## 1.9 INSTALLING AND REMOVING FLOATS

For 13000 float installation and removal instructions for the DHC-6, follow the appropriate checklists provided in Appendix A of this document. These checklists are derived from the requirements of the appropriate aircraft, engine and component manufacturers maintenance manuals, service publications and STC instructions for continued airworthiness.

## CHAPTER 2 MAIN AND NOSE GEAR OPERATION, REMOVAL & SERVICE

### CONTENTS

2.1 DESCRIPTION AND OPERATION.....	22
2.2 SERVICE – NOSE GEAR .....	23
2.3 SERVICE – MAIN WHEELS AND BRAKES .....	23
2.4 SERVICE – MAIN GEAR OLEO .....	23
2.5 SERVICE NOSE AND MAIN GEAR RAMS .....	29
2.6 MAIN AND NOSE GEAR REMOVAL AND DISASSEMBLY.....	30

## 2.1 DESCRIPTION AND OPERATION

Retraction and extension of the main and nose landing gear is effected by a hydraulic actuation system shown schematically in figure 2.1.

The gear system is hydraulically actuated and driven by two hydraulic pumps located on the fuselage bulkhead 60.00.

A pressure of between 525 and 1250 psi is maintained in the supply line. When the pressure falls below 525 psi, the pressure switch activates the pump solenoid, providing power to the pump. When the pressure reaches 1150-1250 psi, the pressure switch deactivates the solenoid and the pump motor stops. Figure 2.2 shows the electrical schematic of the system. A check valve on the output side of the pump retains pressure in the system while the pump is off. The pump has an internal relief valve, which directs oil back to the pump reservoir when the line pressure exceeds 1450 psi. The system also has an internal relief valve to protect against thermal expansion when line pressure exceeds 2000 psi.

A cockpit mounted control valve accomplishes the selection of gear up or gear down. Each float gear has individual indicator lights on the control valve allowing the pilot to confirm that each gear has fully retracted or extended.

An emergency hand pump is provided, in case of total electric pump failure, or loss of fluid. The reservoir has additional hydraulic fluid, available only to the hand pump.

The main gear is mechanically locked in both up and down positions. Locking and unlocking is effected utilizing a small amount of lost motion of the actuator rod. Retraction takes place when pressure is exerted on the actuator piston driving the collar along the slide tube. The lock is tripped when the follower slides up the contoured track in the actuator as shown in figure 2.4. A reverse process affects extension. Gear position light proximity switches are closed when the appropriate hook (containing the magnetic material) nests over the locking bar.

Shock absorption for the main landing gear is provided by a hydraulically dampened air spring. Figure 2.5 shows the main components. The oil and air share a common chamber. When the oleo is collapsed, the oil is forced through the main orifice, compressing the air in the upper cylinder. Extension reverses this process. The extended oleo is initially set at the factory to 250 psi no load. In-field adjustment of air pressure and oil volume is described in section 2.2.

The nose gear has an over-center down lock. Retraction occurs when pressure is applied to the forward face of the actuator piston and the carriage is drawn along the tracks in the nose box as shown in figure 2.9. Gear position light proximity switches are closed when the piston containing the magnetic material has reached either end of its travel.

The nose gear consists of composite fiberglass beams that are attached at the bottom to castoring blocks. Inside the block is a castoring pin that is set into the machined fork assembly. The castoring pin allows the nose wheel to pivot in a complete circle. The geometry is such that no shimmy dampers are necessary. A spring loaded ball rides in a groove machined in the castoring pin. This groove is a round pocket on the back face with the result that the cam provides retention of the pin the block and self-centering of the wheel. A thrust bearing is on top of the castoring pin, along with a lower bearing.

## 2.2 SERVICE – NOSE GEAR

The nose gear pivot assembly should be cleaned and greased every 25 hours or more frequently whenever in water for extended period of time. Nose gear tracks to be lightly lubricated along full length with LPS 02616 Dry Lube, or equivalent.

The nose gear pivot bearings are matched to bearing and race. If replacement is necessary, replace entire bearing. The nose wheels contain grease zerks for the wheel bearings. They should be greased every 25 hours. Nose tires are standard 6:00 x 6, 8-ply, inflated to 50 +/- 5 psi.

### NOSE BOX TRACK WEAR

Due to the wear the roller/slide block places on the track as the gear are retracted, the block needs to be measured for the amount of wear. The tolerance for wear is .070 inches. If the wear is, or is less than the limit, it can still be used. If the wear in the track is greater than .070 inches, the block must be replaced. This check is to be done every 200 hours and is part of the maintenance checklist.

13000 Series Floats Gear Track P/N 13A07104 (-001 LT -002 RT)

## 2.3 SERVICE – MAIN WHEELS AND BRAKES

Grease nipples are provided on all wheels and bearings and should be greased every 25 hours or after an extended period of time in the water. Water/heat resistant grease is recommended. At brake installation, apply STA-Lube synthetic brake and caliper grease or equivalent to brake caliper pins. The dual piston brakes need no special care other than to maintain the brake disc free of rust, which causes premature brake lining wear. Bleeding is carried out in the usual manner from the bottom up. Although, since the line is "T"ed to the double brake, one must remember to bleed one segment of the Y first, then finish the entire job through the remaining segment.

**Note:** If replacing any of the (2) bushings located within the drag brace or the (2) within the axle assembly, the internal grooves must be aligned to the zerk fitting and a grease hole must be drilled into the bushing after insertion. These are the "bearings" identified in Figure 2.7.

Main wheel tires are standard 8:50 x 10, 8-ply type III aircraft tires, inflated to 50 +/- 5 psi. (Refer to figure 2.10).

## 2.4 SERVICE – MAIN GEAR OLEO

**Oil Level** - The correct level is best set by draining and refilling with the correct quantity of fluid (1900 ml). This should be done with the oleo removed from the float.

**CAUTION:** Release air pressure and remove air valve before attempting to service oleo. After filling, refit valve and cap, then pressurize to 250 psi. (**Note:** Use only MIL-H-5606 hydraulic fluid).

**Air Pressure** – The correct air pressure is 250 psi (+/-10 psi) on a fully extended oleo (no load) or it can be inflated to approximately 3-4 inches on an unloaded aircraft while sitting static on level ground.

**Seals** – Seals should be replaced whenever the oleo is disassembled or leaking.



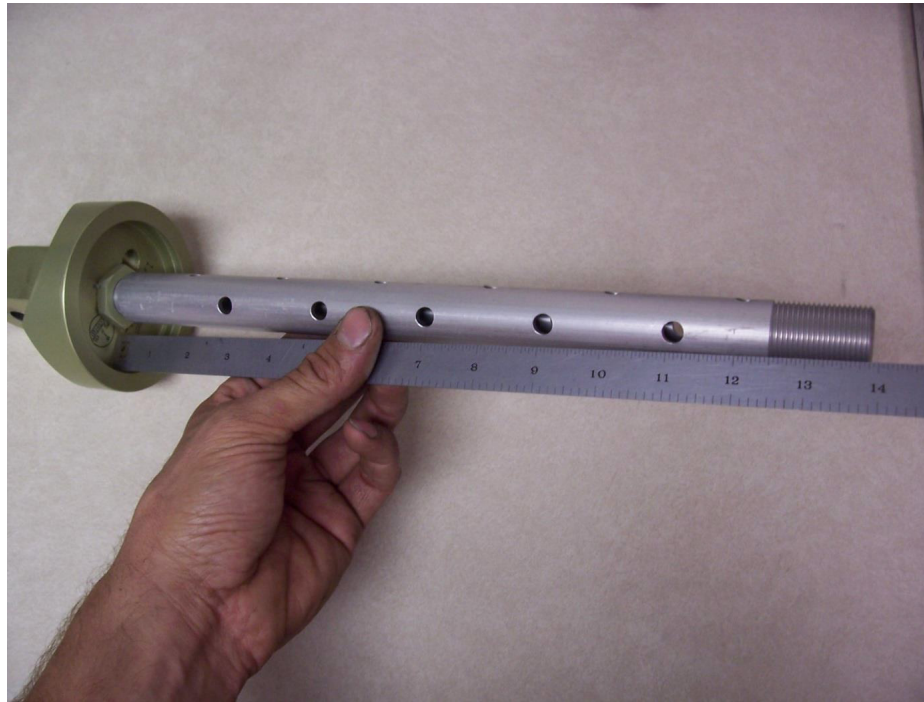

4. On the other end, install the metering pin with Loctite onto the end-cap and tighten to approx. 30 ft./lbs.
5. Install outer T-seal to end-cap with Vaseline. Install inner cylinder into top end cap with PR-1422.

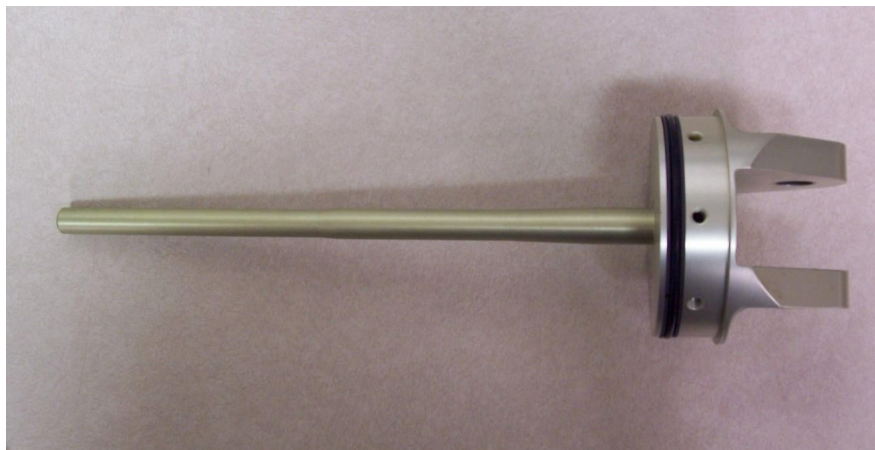

6. Install the end-cap bolts with gasket sealer on the threads for added security. Tighten to 25-30 in./lbs. making sure not to over-tighten, damaging the T-seal. Set this part of the unit aside and move on to next steps.



7. To assemble the gland assembly, insert the inside T-seal and wiper, again using Vaseline on the T-seal.
  - a. The gland must be installed from the end-cap side (this is the side without the holes).
  - b. Lube the outside of the inner cylinder with hydraulic fluid for ease of assembly.
  - c. Install the T-seal into the end-cap, again using Vaseline for lube.
  - d. Install the inner cylinder into the end-cap (the end of the tube without holes).

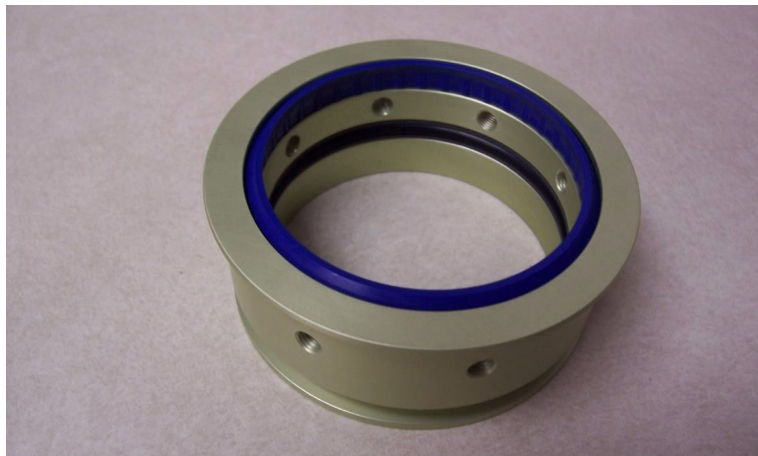

8. For piston install, place the piston onto the metering tube using hydraulic fluid for lube to prevent damage to the threads.
  - a. Using a spanner wrench, tighten the piston to the inner cylinder.
  - b. Install the jam nut onto the piston end of the metering tube and stake for security.
  - c. Install the 2 T-seals onto the exterior of the piston and gland, and lube with Vaseline.



9. Gently clamp the outer tube end in a vise and add 1900 ml of hyd. fluid (5606 or equivalent).
10. Lube the inside of the outer cylinder where the gland and the piston will rest.
11. Install the inner cylinder into the outer assembly, making sure that the gland is seated against the piston.



12. Re-install the center bolts using gasket sealer.



13. Install the O-ring onto the fill/drain plug before installing the plug onto the end-cap and tighten.



14. Install the O-ring onto the Schrader valve and install onto the outside of the end-cap.

**NOTE: Align Schrader valve 180 degrees from the Placard.**

**NOTE: Double check the plugs and bolts for proper installation and security before adding gas charge.**

15. Fill the strut with nitrogen to 250 psi +/- 10 psi and close the valve and cap.



## 2.5 SERVICE NOSE AND MAIN GEAR RAMS

Lubricate the nose and main gear cylinder mounting flanges with MIL-H-5606 Hydraulic Fluid thru the oilers. The nose has a flip-lip type oiler and the mains have a ball-needle type oiler. The purpose is to wet the felt wiper so it pre-lubes the penetration rams and enables the seals inside to work and not become damaged over time.

### ADJUSTMENT/TEST

#### NOSE GEAR

Adjustment of actuator stroke is provided at the ends of the piston rods. The length of the nose gear rod is adjusted such that the over-center knuckle (brass) rollers just bottom out on the down side and the piston just bottoms out on the mounting flange at the same time.

The up stops nests in the up-stop bolt. See figure 2.9 and 2.10 for locations and assembly. Nose gear proximity switches are located on clips that are mounted on the outer cylinder body, one on each end. The most forward switch is for the gear down lights and most aft is for the gear up position lights. Set the proximity switch mounting clip along outer cylinder body to a position such that the light goes out when the over-center track is about  $\frac{1}{4}$  inch from bottomed position while traveling in the up direction. Lights should come on about  $\frac{1}{8}$  inch from the bottomed position while traveling in the down direction. The cylinder piston has a magnet that will activate the proximity switches.

#### MAIN GEAR

The main gear actuator cylinder is not adjustable. These are pre-set at the factory to ensure that the main gear is locked at the end of each stroke and that correct indication is given on the cockpit console. The up and down lock may be adjusted so the lock is fully engaged by adjusting the set screws shown in figure 2.4. Loosen the jamb nut adjust and tighten jamb nut.

The service intervals on the Main Gear Actuators should be every 25 hours if the aircraft is regularly taxiing on sand and gravel. Otherwise they should be cleaned and serviced according to the checklists from the back of this manual. Clean the slide tube with clean solvent remove any buildup of dry or dirty lubricants. Inspect the slide tube for erosion and/or nicks and protrusions caused by gravel or debris being thrown by the Main Landing Gear tires. Grease the actuator mechanism with HCF grease, p/n 605, or equivalent and wipe the slide tube down with a clean rag soaked in lubricant.

The main gear proximity switches are located on each end of the gear stroke. The forward switch is located on the forward side of the gear tunnel. It is accessible through the top deck access cover. The aft proximity switch is located on the float bulkhead just aft of the wheel well, accessible through the float top deck cover.

The main gear proximity switches are adjusted loosening the mounting screws and positioning them as such that the light goes out when the lock hook is raised about  $\frac{1}{8}$  inch off its nested position and comes on again upon nesting.

#### BLEEDING HYDRAULIC SYSTEM AFTER SERVICE

The system automatically bleeds, provided sufficient oil is maintained in the reservoir. To check the fluid level, fill the reservoir with hydraulic oil and cycle the gear. The fluid level should be maintained in the upper one third ( $\frac{1}{3}$ ) of the sight glass. If the reservoir empties (i.e. fluid disappears in sight glass) stop the cycle by pulling the circuit breaker on the control panel. Fill the reservoir again and complete the cycle. Continue this procedure until the fluid level in the reservoir stabilizes (it will vary in level between up and down positions). If the fluid level continues to decline during gear cycles, check for external leaks. Generally, the fluid level in the site glass should be about  $\frac{3}{4}$  full when the gear is down.

## 2.6 MAIN AND NOSE GEAR REMOVAL AND DISASSEMBLY

### REMOVAL OF MAIN GEAR OLEO

Jack the aircraft by method described in section 1.2. With main wheels off the ground (both sides), run the gear up so that the main carriage is approximately 2 inches forward of down lock position. This must be accomplished to remove the top oleo bolt. In order to remove the lower bolt, it is necessary to remove the wheel on the head side of the bolt.

### REMOVAL OF MAIN GEAR RETRACTION CYLINDER

Relieve pressure in system, place gear selector handle in neutral position (lever between up and down), and remove hydraulic lines. Remove end cap from end of cylinder. Drain fluid. Remove forward end of cylinder from bulkhead flange. Remove both cylinder support rings from the bulkhead. NOTE: Piston to be in the up position for cylinder removal. Remove cylinder from piston and up through top float inspection cover. To remove piston, remove top inspection cover on top forward end of gear tunnel, accessible from top float inspection cover forward of step. Pull back piston to expose top of carriage in center of access cover. Remove .25 dia. retention bolt. Remove piston by pulling aft. See figure 2.6 for part breakdown.

### REMOVAL OF MAIN GEAR DRAG LINK

Remove drag link from trunnions on step bulkhead. Axle is heat shrunk to drag link and is not removable.

### REMOVAL OF NOSE GEAR TROLLEY ASSEMBLY FROM NOSE BOX

Gear must be in down position. Unbolt the spring from the trolley. Relieve the pressure in system, place gear selector handle in neutral position (lever between up and down), and remove rear hydraulic line. Remove (4) bolts on forward end of cylinder. Drain fluid. Pull aft to expose internal piston rod. Loosen jamb nut on forward side of cylinder ram at rod end. Turn piston from aft side of nose box out of rod end. Push on trolley assembly to unlock and remove the bottom thru-bolts. Slide out of nose box. Note: On installation, adjust piston so it bottoms out on aft flange at the same time as the bearings when nose gear is in locked position. Also note orientation of trolley blocks. The side with the most edge distance from hole is to go toward each other on inside of trolley. (See figure 2.9 for details).

### REMOVAL OF NOSE GEAR BOX

Remove bolts securing forward box from nose bulkhead. Remove bolts securing aft box from bulkhead (2). Slide box out from front of float. Note: Sealant will have to be cut for removal and replaced when installing.

### REMOVAL OF LOWER NOSE GEAR FROM PIVOT BLOCK

On top of pivot block, remove cotter pin from retaining nut. Remove nut. On aft side of pivot block, remove the (2) cap bolts on .25 thick cover. Remove spring. This will loosen retaining ball and lower fork will slide out. Refer to figure 2.10 for assembly.

### REMOVAL OF NOSE GEAR

Remove the nose gear from the nose box by unbolting the spring (4 bolts).

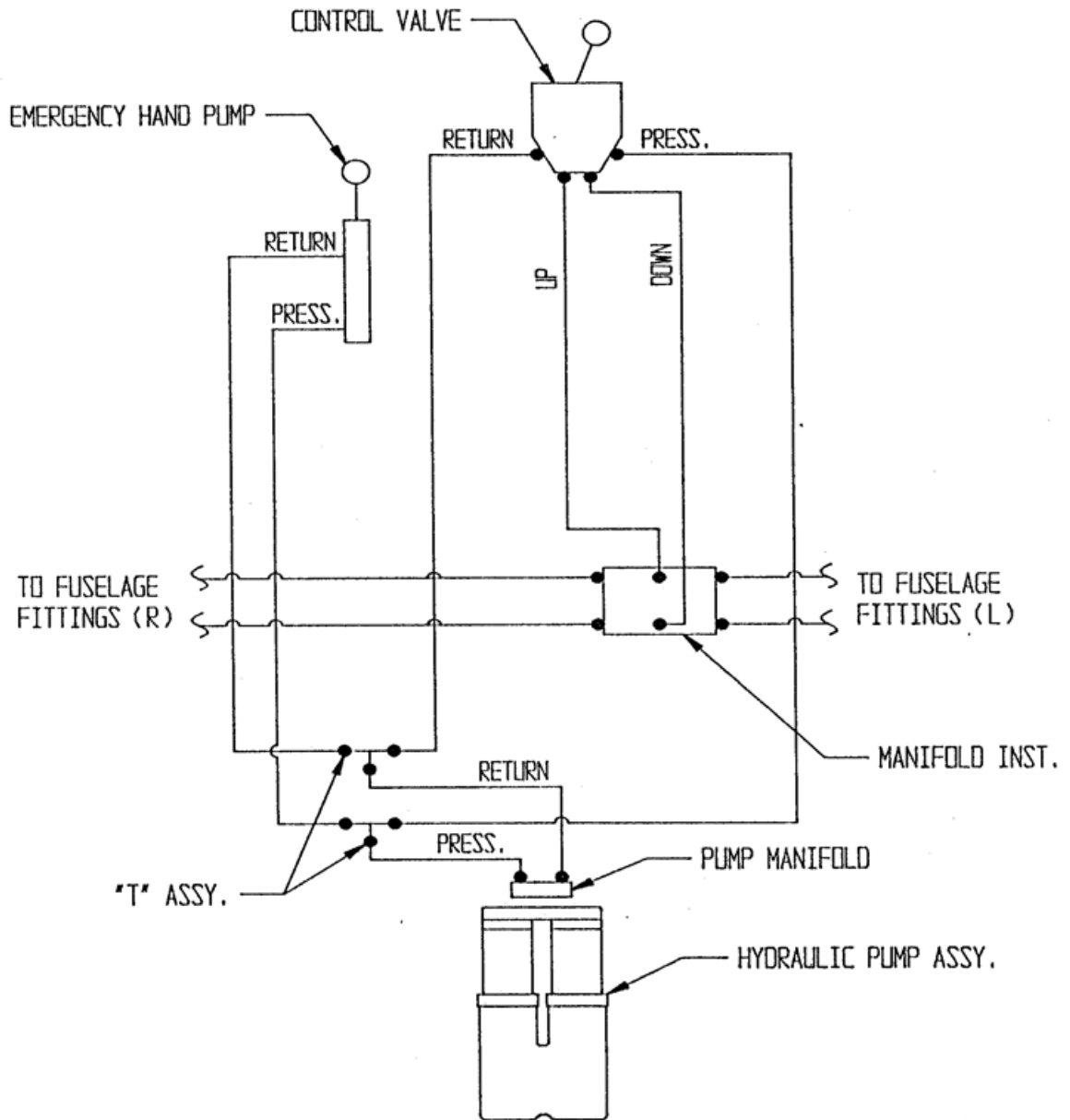
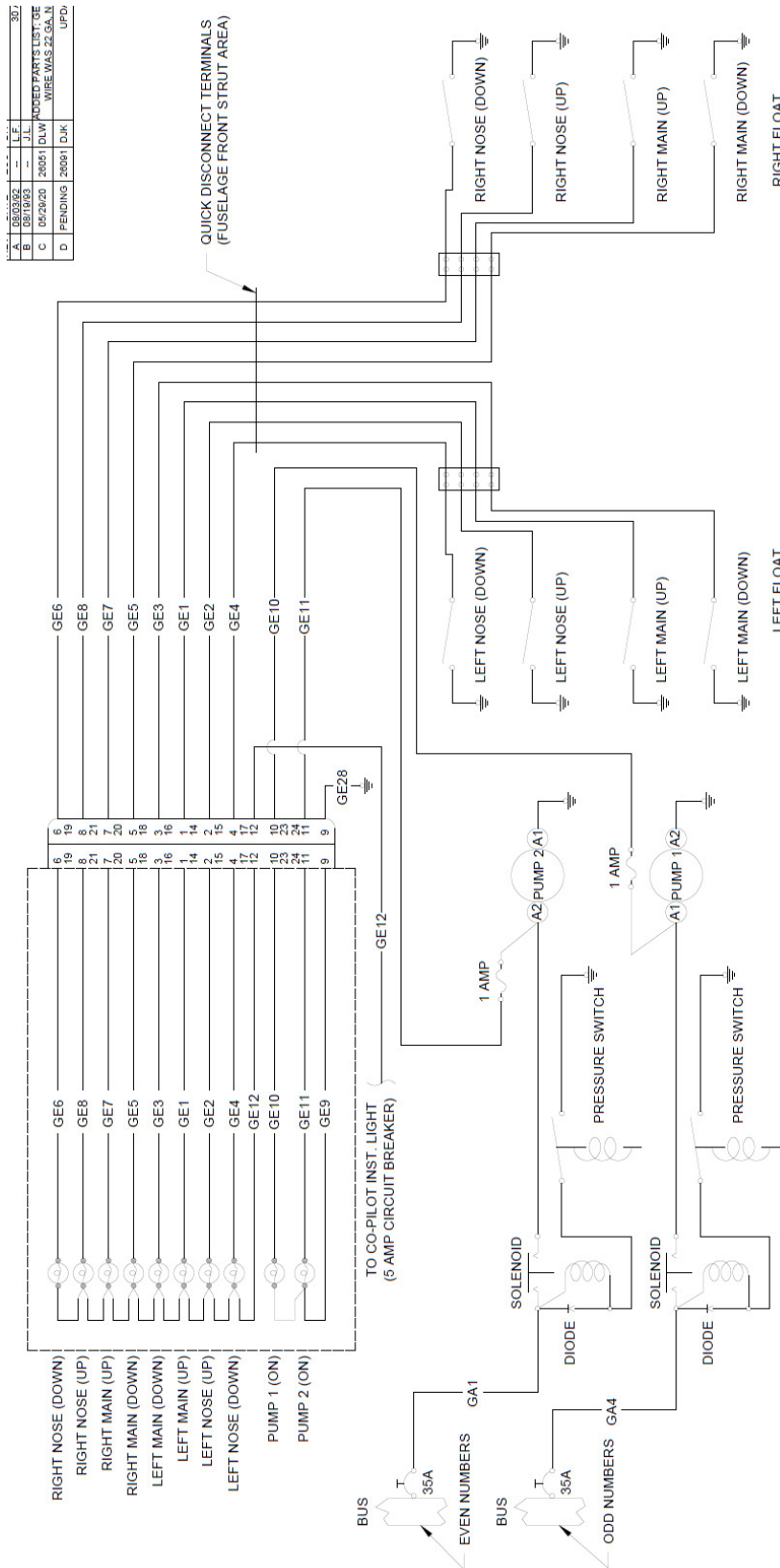
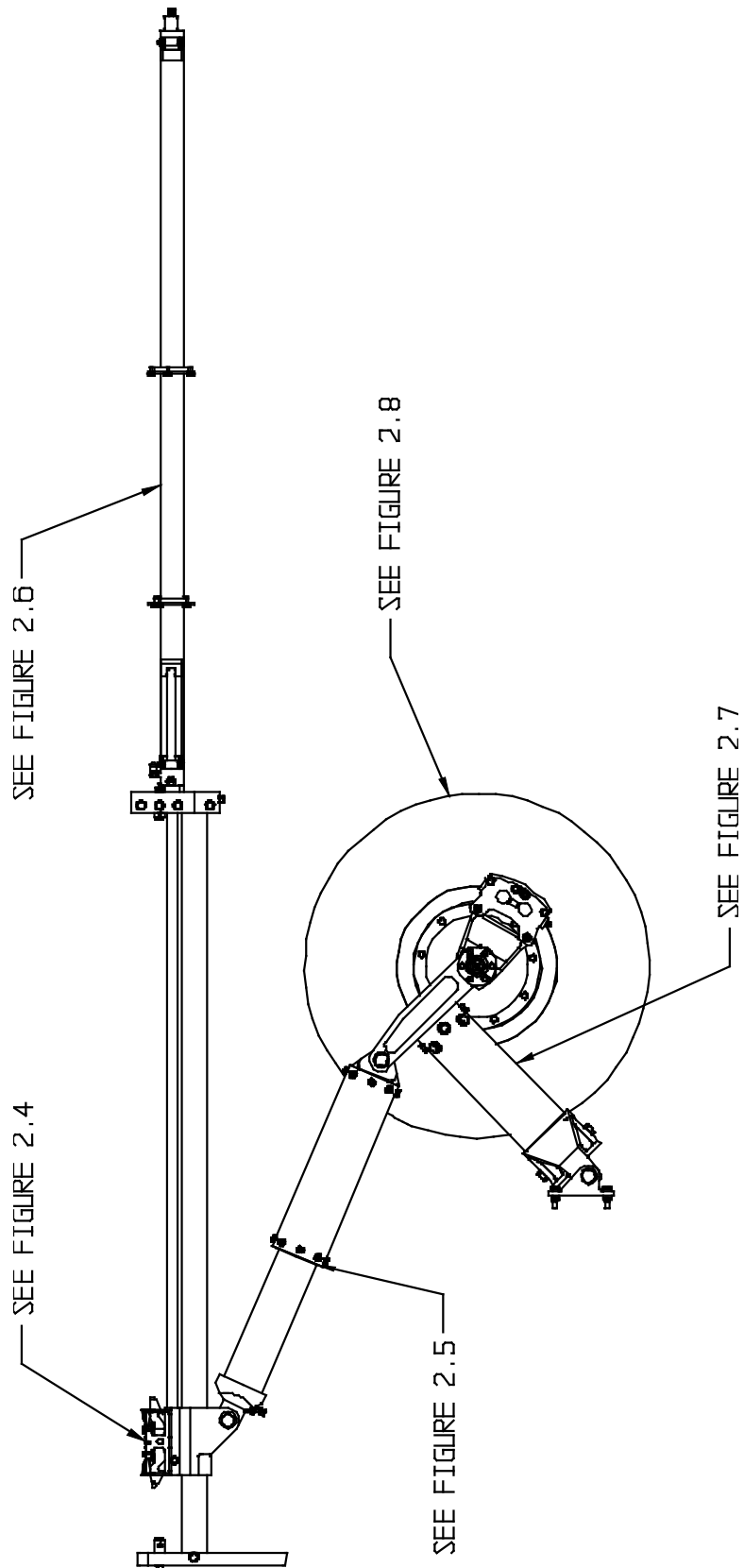

FIGURE 2.1 HYDRAULIC SYSTEM SCHEMATIC



**FIGURE 2.2 SCHEMATIC – ELECTRICAL SYSTEM**



**FIGURE 2.3 LAYOUT - MAIN GEAR**

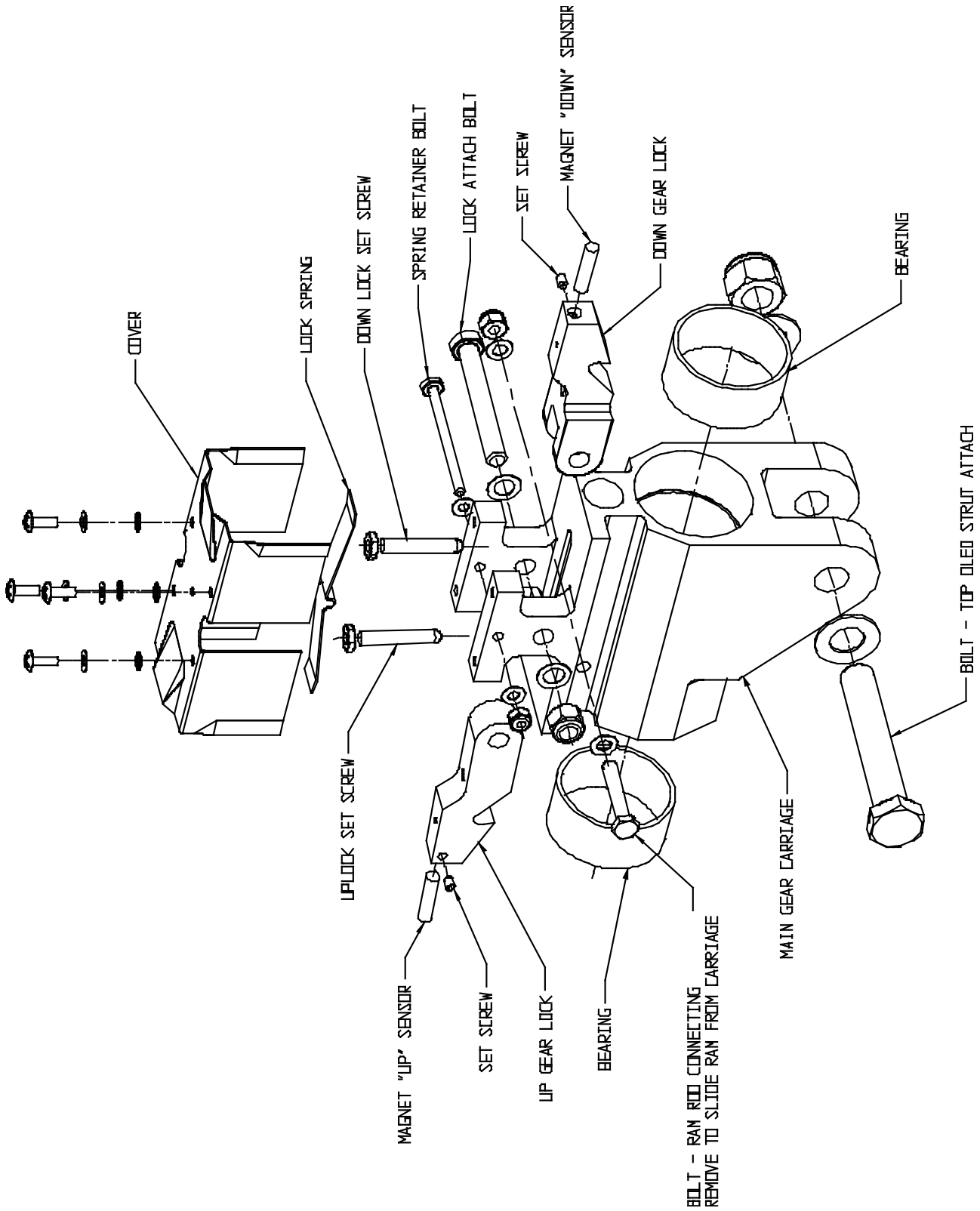

**FIGURE 2.4 CARRIAGE ASSEMBLY - MAIN GEAR**

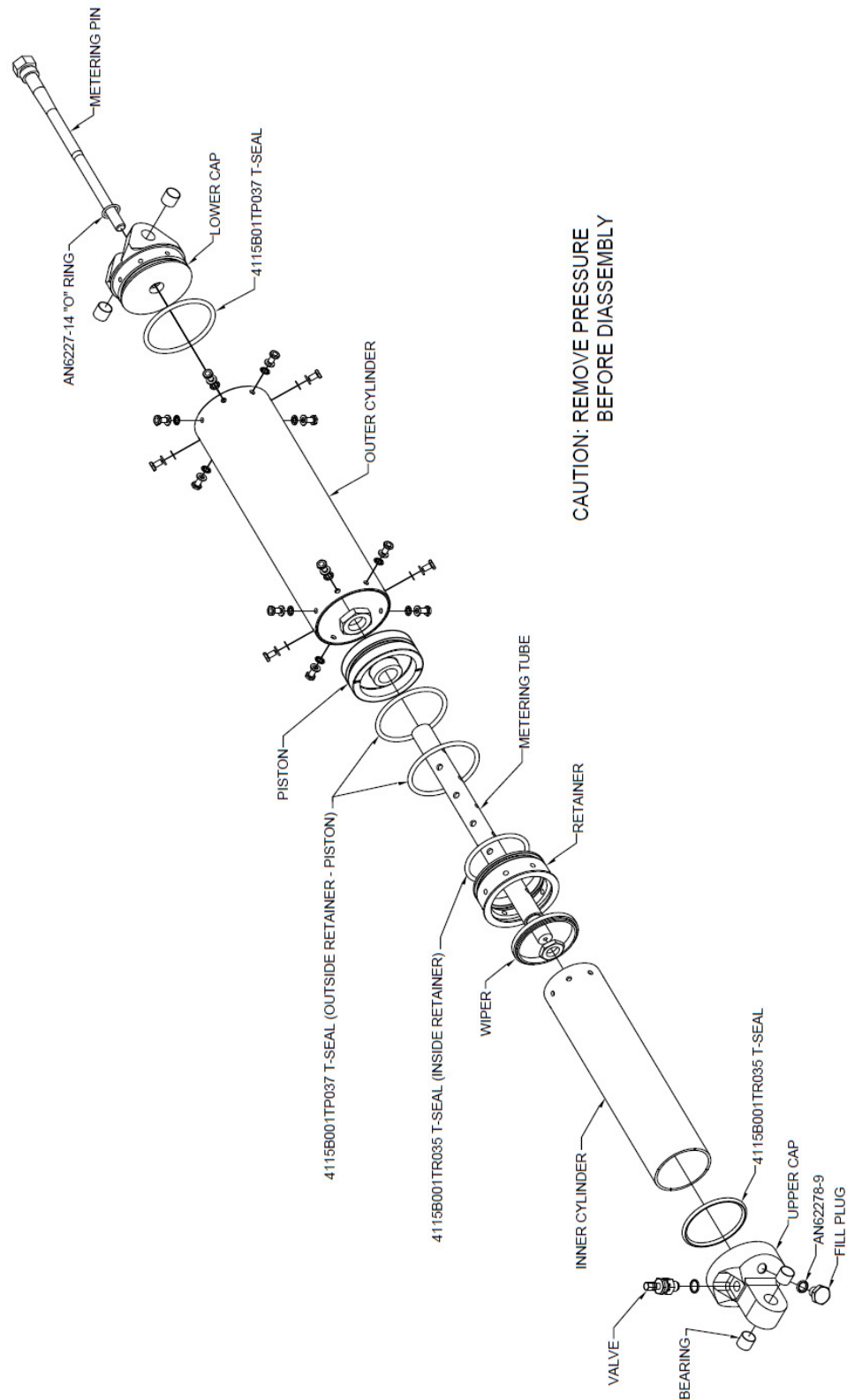

**FIGURE 2.5 ASSEMBLY – MAIN GEAR SHOCK STRUT**

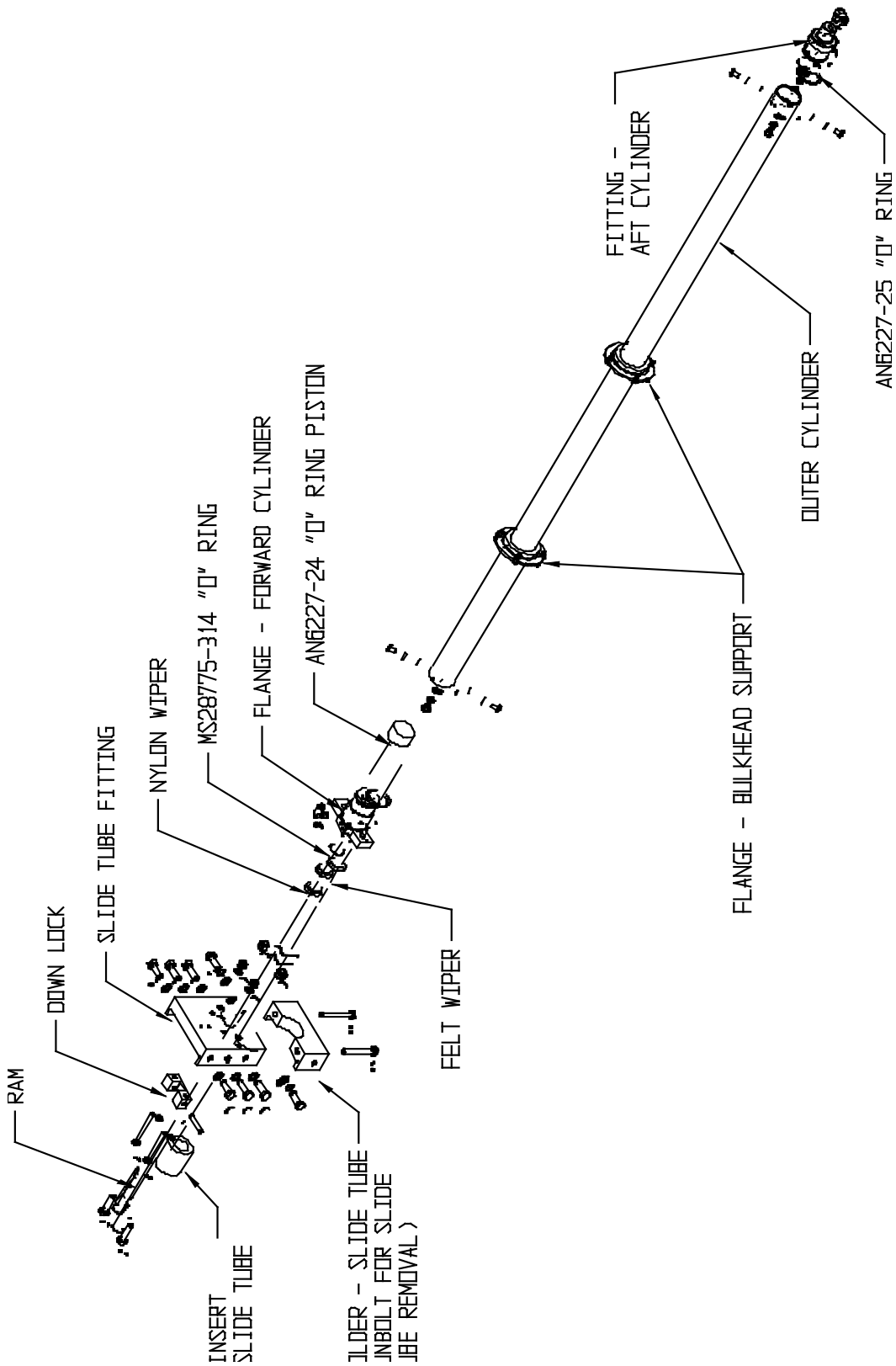

**FIGURE 2.6 ASSEMBLY - MAIN GEAR CYLINDER**

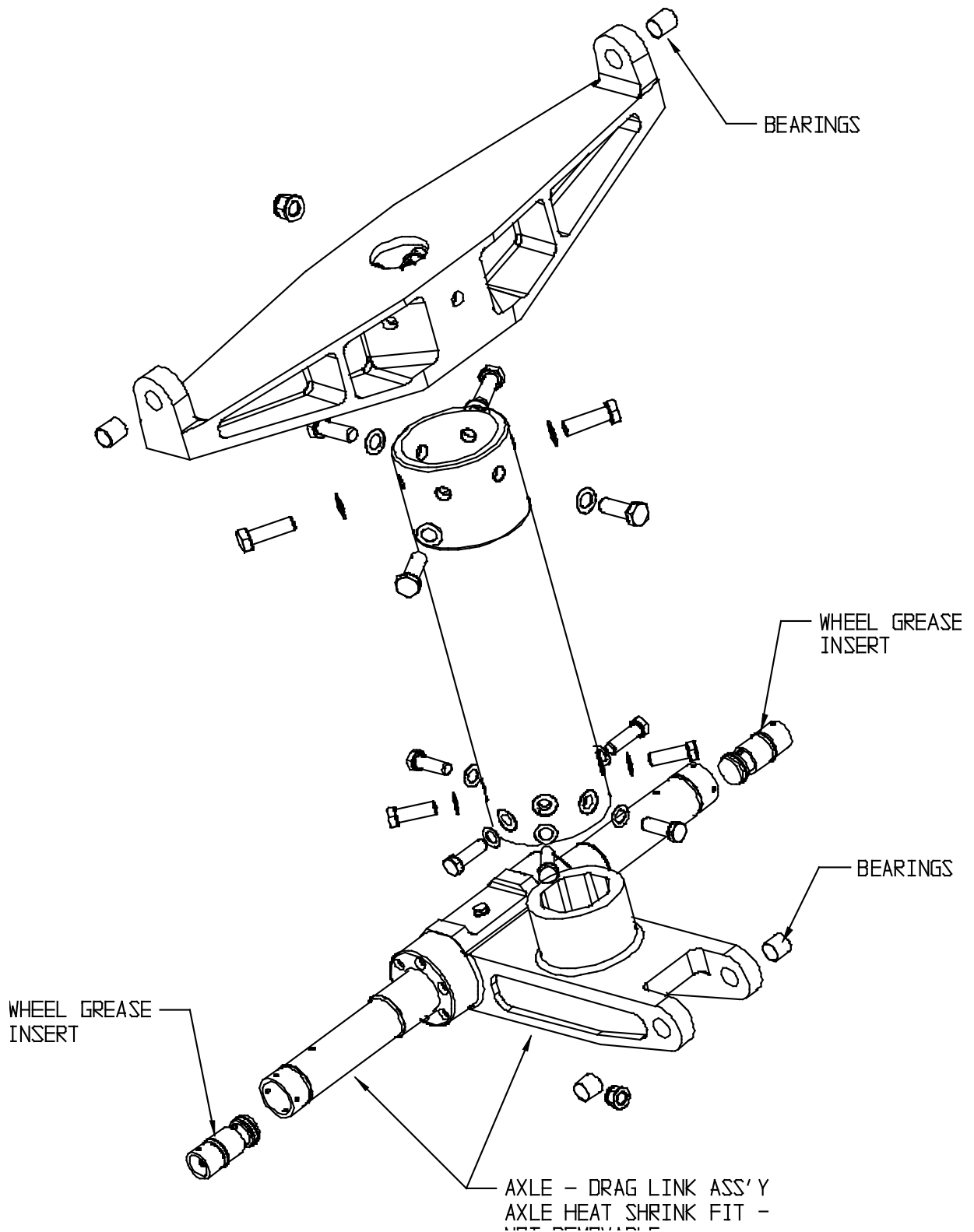

**FIGURE 2.7 ASSEMBLY – MAIN GEAR DRAG LINK**

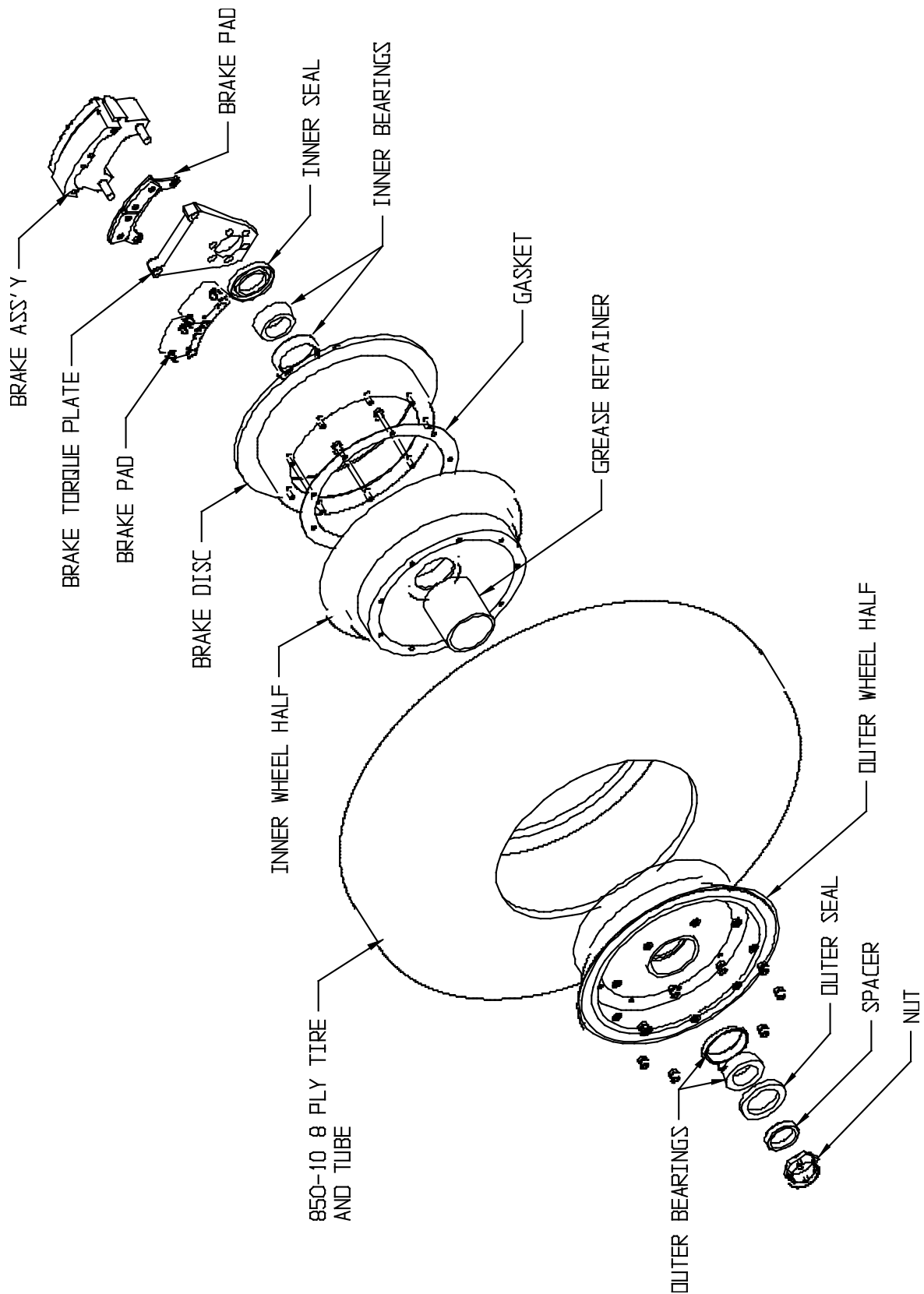

**FIGURE 2.8 ASSEMBLY – MAIN GEAR WHEEL AND BRAKE**

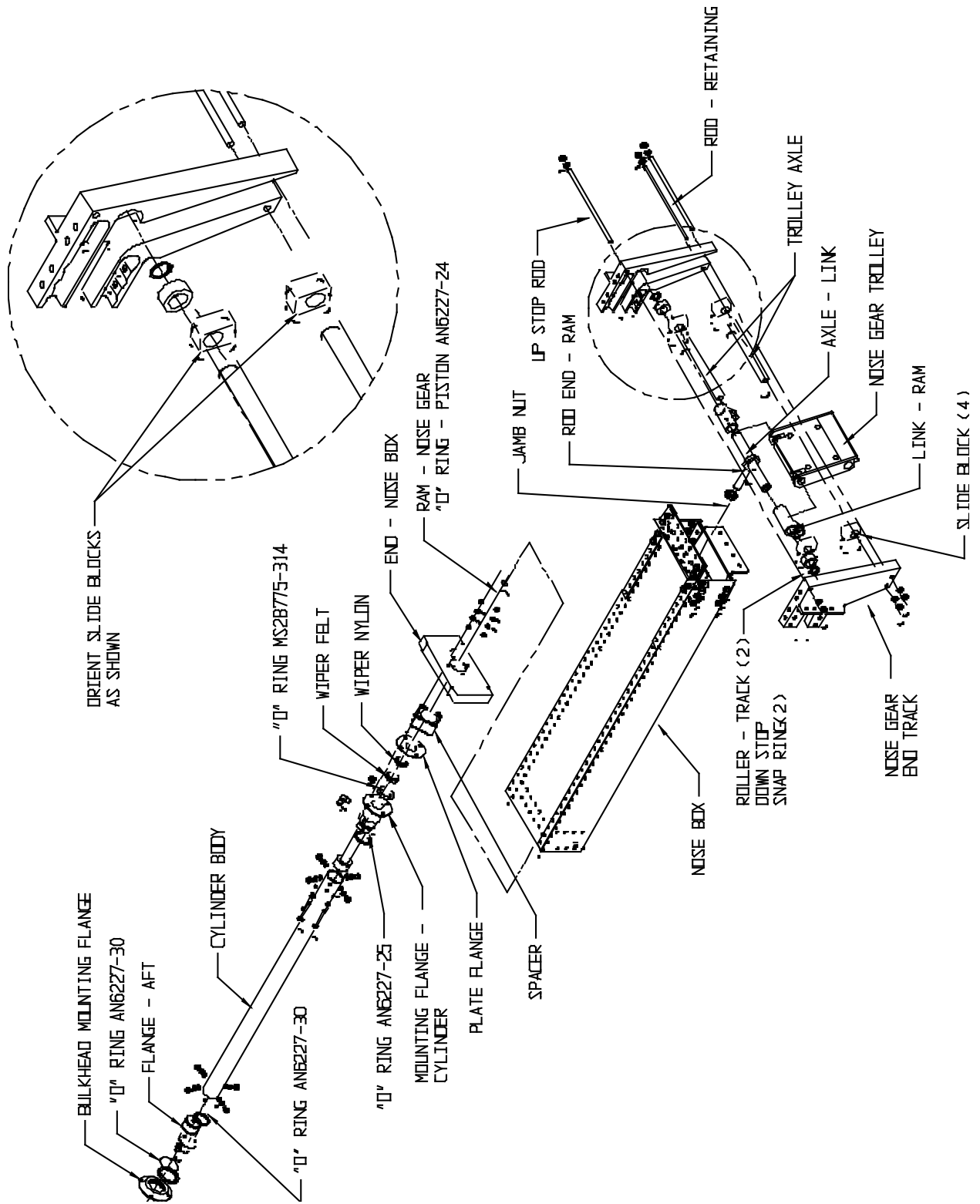

FIGURE 2.9 ASSEMBLY - NOSE GEAR BOX AND RETRACTION



## **CHAPTER 3 HYDRAULIC PUMP SYSTEM, DISASSEMBLY & SERVICE**

### **CONTENTS**

3.0 HYDRAULIC PUMP SYSTEM, DISASSEMBLY AND SERVICE .....	42
3.1 OPERATION TROUBLESHOOTING .....	42

### 3.0 HYDRAULIC PUMP SYSTEM, DISASSEMBLY AND SERVICE

The hydraulic pump is factory preset to the following pressures:

Pressures switch operates below 525 psi and shuts off at 1250 psi. The pump also has an internal relief valve that opens at 1450 psi and a thermal relief valve that opens at 2000 psi. These pressures are set with factory test equipment and are recommended to be sent back for overhaul or repair. The unit may be disassembled for cleaning.

1. Relieve the pressure in the hydraulic system by placing the gear selector handle in the neutral position.
2. On the forward lower side of the reservoir, remove drain plug to drain most of the hydraulic fluid.
3. Remove the (4) screws on each tank (2) on upper side of the reservoir. Dump out remaining oil, and clean reservoir.
4. Unscrew stand pipe with the filter attached.
5. Clean filter.
6. If filter is removed from stand pipe, a new filter should be used.
7. Reinstall tank and install seals to top of reservoir before installing on pump.
8. Install drain plug and fill with clean MIL-H-5606 hydraulic fluid through the breather pipe.
9. Fluid level should be in the upper 2/3 of the sight gauge
11. If the fluid is not a clean, red color, it should be replaced with new fluid.

### 3.1 OPERATION TROUBLESHOOTING

1. **Problem** - Power pack does not run after gear selection.

#### PROBABLE CAUSE

- a. Circuit breaker has failed
- b. Pressure switch not pulling in at low cut in.
- c. Solenoid switch not pulling in.
- d. Faulty pump motor.
- e. Motor not properly grounded.

#### VERIFICATION AND REMEDY

- a. Reset circuit breaker.
- b. Short across pressure switch leads and see if motor runs. If motor operates, replace pressure switch.
- c. Short across solenoid pressure switch leads and see if motor runs. If motor operates, replace solenoid pressure switch.
- d. If c. above does not produce results and it is verified that voltage was actually applied to motor, it can be assumed motor is bad or not properly grounded.
- e. Check motor ground.

2. **Problem** – Power pack does not shut off after gear reaches position.

#### PROBABLE CAUSE

- a. Faulty pressure switch.
- b. Faulty or dirty pressure relief valve allowing insufficient pressure buildup.

**REMEDY**

- a. Replace pressure switch.
- b. Clean and check relief valve.

**3. Problem** - Powerpack shuts off before gear reaches position.

**PROBABLE CAUSE**

- a. Binding or jammed gear retractor, which causes pressure to build up (and stay up), and pressure switch shuts off powerpack.

**REMEDY**

- a. Repair retractor.

**4. Problem** - Powerpack cycles on and off after gear is in position.

**PROBABLE CAUSE**

- a. Internal hydraulic leak.
- b. External hydraulic leak.

**REMEDY**

- a. Verify leak is not external by checking fluid level in reservoir and looking at couplings for oil leaks. If no external leaks are found, disconnect and cap off the hydraulic actuators one at a time and find the leaky one by process of elimination. If isolating entire system still indicates internal leak, power pack check valve (located in pressure port of pump) is bad and needs replacement or reseating.
- b. Visually inspect lines, cylinders, and hoses and replace as necessary.

**5. Problem** – Power pack cycles on and off during gear cycle.

**PROBABLE CAUSE**

- a. Binding in retraction unit.
- b. Pressure switch cut off limit too low.

**REMEDY**

- a. Investigate for free operation. Check gear that retracts last.
- b. Replace pressure switch.

**6. Problem** - Slow gear operation cycle (considerably longer than 30 seconds).

**PROBABLE CAUSE**

- a. Plugged oil screen.
- b. Poor electrical connection to motor.
- c. Poor motor.
- d. Worn pump gears.

**REMEDY**

- a. Clean intake screen located inside reservoir tank.
- b. Connect motor direct to 24 volt source and note its operation; if good, wire connection is bad; if operation poor, motor needs overhaul.
- c. Covered in b. above.
- d. Replace pump.

**7. Problem** - Circuit breaker pops during cycle.

**PROBABLE CAUSE**

- a. Wire connections bad or corroded.
- b. Bad motor brushes.
- c. Bad circuit breaker.

**REMEDY**

- a. Clean and protect terminal with grease.
- b. Overhaul motor.
- c. Replace circuit breaker.

## CHAPTER 4 REPAIRS

### CONTENTS

4.0 REPAIRING FLOAT SKINS AND EXTRUSIONS .....	46
--	----

## **4.0 REPAIRING FLOAT SKINS AND EXTRUSIONS**

For all float skin and extrusion structural repairs, refer to Wipaire's Structural Repair Manual (SRM) part number 1008274.

## CHAPTER 5 CONTINUED AIRWORTHINESS

### CONTENTS

5.0 CONTINUED AIRWORTHINESS .....	48
5.1 RECOMMENDED LUBRICANTS AND CORROSION PRODUCTS.....	49
5.2 INSPECTION CHECKLIST .....	51

## 5.0 CONTINUED AIRWORTHINESS

As coded in the Inspection Time Limits chart in this section, there are items to be checked each 25, 50, 100, and 200 hours. Also, there are notes on special items, which may require servicing at more frequent intervals.

- When conducting an inspection at 25 hours, all items marked for 25 hours would be accomplished.
- When conducting an inspection at 50 hours, the 25 and 50 hour items would be accomplished.
- When conducting an inspection at 100 hours, the 25, 50, and 100 hour items would be accomplished.
- When conducting an inspection at 200 hours, the 25, 50, 100 and 200 hour items would be accomplished.
- A complete inspection (Annual Inspection) would include all 25, 50, 100, 200 hour items.

As general inspection guidelines, each of the following areas should be inspected for their own unique attributes:

### **Movable Parts**

For lubrication, servicing, security of attachment, binding, excessive wear, safetying, proper operation, proper adjustment, correct travel, cracked fittings, security of hinges, defective bearings, cleanliness, corrosion, deformation, sealing and tension.

### **Fluid Lines and Hoses**

Fluid Lines and Hoses - For leaks, cracks, dents, kinks, chafing, security, corrosion, and deterioration.

### **Metal Parts**

For security of attachment, cracks, metal distortion, broken welds, corrosion, condition of paint, and any other apparent damage.

### **Wiring**

For security, chafing, burning, defective insulation, loose or broken terminals, corroded terminals.

### **Bolt Torque**

Bolts in Critical Areas - For common, correct torque when installed, or when visual inspection indicates a need for a torque check.

Bolt and nut torque should be applied per the specified manufacturer recommended torques (see non-standard bolt torques table in Section 7). If no bolt torques are specified, use AC43 standard torques (see standard bolt torque table in Section 7).

Some additional general maintenance areas are as follows:

### **Main Gear Locks**

Clean and lubricate as necessary to keep grease present at all times. Water resistant grease is recommended.

### **Joints**

Spray all joints with light penetrating oil such as LPS 3 to ensure lubrication at all times.

### **Electrical Connections**

Apply SOFT SEAL or LPS 100 paste to all electrical connections to prevent corrosion.

## 5.1 RECOMMENDED LUBRICANTS AND CORROSION PRODUCTS

Below is a list of recommended lubricants and “protection” products when servicing float hull and amphibious components. This lists products used by Wipaire during assembly of the floats.

There may be equivalent products just as satisfactory for protection. However, it is recommended if trying different products, to inspect them frequently so as to determine their effectiveness.

### **Protection of nuts, bolts, hydraulic lines or metal surfaces**

Zip D-5029NS Corrosion Inhibiting Compound  
Zip Chemical Company

CRC – SP400 Soft Seal  
CRC Industries

### **General Lubricants**

LPS 1, LPS 2 and LPS 3  
LPS Industries

### **Wheel Bearings, Main Gear Retract Mechanism, Nose Gear Pivot and Rod Ends**

\*HCF Grease, P/N 605  
HCF Industries

\*Aeroshell 22  
Shell Global Solutions

\*Green Grease, Multi-purpose  
Green Grease Inc.

\*Aviation Grease SHC 100  
ExxonMobil Aviation Lubricants

### **Rust Protection**

Boeshield T9 Rust Protection  
Boeing Company

ACF-50 Rust Protection

Corrosion X  
Corrosion Technologies Corp.

Tef-Gel  
Ultra Safety Systems, Inc.

### **Float Sealant**

890 B2 or B4  
Pro Seal Company

PR 1440 C  
PPG Aerospace

1422 B2, B4 or B6  
Pro Seal Company

RTV Silicones  
General Electric

SIKAFLEX 201 or 252  
Sika Manufacturing

**Hydraulic Fluid**  
Mil-H-5606

**Electrical Insulating Compound**  
Dow Corning 4 (DC4)  
Dow Corning Corporation

**Brake Caliper Grease**  
STA-Lube

\*If existing grease cannot be identified you must lubri-flush all float grease fittings until visibly exhausting all old grease and new grease is coming out. Additionally, if you cannot determine existing grease in wheel bearings, completely clean and repack bearings with new grease.

## 5.2 INSPECTION CHECKLIST

INSPECTION TIME LIMITS		HOURS					MECHANIC	
		25	50	100	200	RT	LT	
<b>General</b>	Placards				X			
<b>Hulls &amp; Struts</b>	Float Installation		X					
	Float exterior - inspect for damage, wrinkled metal, corrosion, paint loss, etc.							
	Struts & attach fittings			X				
	Spreader bars			X				
	Float Structure (interior)				X			
	Inspection Covers - inspect for condition, security and seal.			X				
	Pumper Tube Installation - inspect for condition, security, routing of hoses.				X			
<b>Electrical System</b>	Pump and indicator light wiring - inspect for chafing, broken or loose terminals and general condition.					X		
	Solenoids - inspect for wiring, mounting and general condition.					X		
	Pressure Switches - inspect wiring, mounting and general condition.					X		
	Pump motors - inspect wiring, mounting and general condition.					X		
<b>Landing Gear Systems</b>	Lubricate nose gear tracks						X	
	Nose Gear Box/Block Tracks measured at slide route for wear, .070 inches or less wear tolerance.							X
	Nose gear pivot blocks and forks - inspect for condition, lubrication, corrosion, paint.						X	

INSPECTION TIME LIMITS		HOURS					MECHANIC	
		25	50	100	200	RT	LT	
Nose and Main Wheel Bearing - grease Zerk fittings.		X						
Hydraulic Fluid Level			X					
Wheels and Tire - inspect for wear, pressure, condition.			X					
Brake Assemblies - inspect for wear, corrosion, leakage.			X					
Hydraulic Fluid Screen - clean and inspect. Note: If floats sit for extended periods of time (i.e. if removed during winter months), screen should be cleaned before putting floats back into service. Hydraulic fluid in reservoir should be checked for moisture or other contaminants and changes if necessary.				X				
Insp. FWD slide tube mounting bolt for corrosion and wear when the gear are out. Clean and lube the slide tube before returning.				X				
Check slide tube condition for corrosion (specifically in area where carriage is in gear down position) and for gouging along slide tube assembly. Lubricate slide tube (remove excessive old grease to prevent over lubrication/contamination).	For aircraft that are used in high-cycle and heavy-seas/ ocean operations. High-cycle is defined as averaging greater than 3 takeoff/landing cycles per hour.	X						
Main and Nose Gear Actuator, assemblies - inspect for condition, lubrication, leakage, corrosion, and cleanliness.				X				

INSPECTION TIME LIMITS		HOURS				MECHANIC	
		25	50	100	200	RT	LT
	Nose gear springs - scotch-ply springs, inspect for cracks, delamination and paint.			X			
	Main Gear Drag Link garlock bushings - inspect for condition, lubrication, corrosion.			X			
	Main Gear Oleos - inspect for evidence of leakage, proper extension, check cylinder for corrosion, pitting, cleanliness and security.			X			
	Hydraulic Lines & Fittings - inspect for leaks, condition and security.				X		
	Hydraulic manifolds (if equipped) - inspect for condition, security and leaks.				X		
	Brake System Plumbing - inspect for leaks, condition and security.				X		
	Main Gear Oleos - Service				X		
	Perform retraction test:				X		
					X		
					X		
					X		
					X		
	Nose and main wheel bearings - disassemble and inspect				X		

THIS PAGE INTENTIONALLY LEFT BLANK

## CHAPTER 6 WEIGHT AND BALANCE

### CONTENTS

6.0 WEIGHING PROCEDURES FOR THE DHC-6 AMPHIBIAN.....	56
--	----

## 6.0 WEIGHING PROCEDURES FOR THE DHC-6 AMPHIBIAN

Level aircraft per manufacturer's instructions.

Place scales under the right and left nose and main gear wheels.  
Place blocking under right and left main gear wheels to level aircraft.

Drop plumb bob from wing leading edge on either side of the plane to the floor and mark. This is the datum-line, station 0.0.

Draw another line between the nose wheel centers and a 3rd line between the main wheel centers.

Measure the distance from 0.0 to the nose wheel line. This is X.  
Measure the distance from 0.0 to the main wheel line. This is Y.

Use this table for the calculations:

	Scale Reading	Dist from 0.0	Weight x Arm
	<b>Weight</b>	<b>x</b>	<b>Arm</b>
			<b>=</b>
			<b>Moment</b>
Left Front	+	-	X
Right Front	+	-	X
Left Rear	+	+	Y
Right Rear	+	+	Y

Totals

### Notes:

1. Zero out or deduct tare weights at the Y arm.

## CHAPTER 7 BOLT TORQUES

### CONTENTS

7.0 BOLT TORQUES .....	58
------------------------	----

## 7.0 BOLT TORQUES

In the absence of any preempting data such as that found on installation drawings, use the NON-STANDARD table below for the listed fasteners. If the nut and bolt torque is not included in the NON-STANDARD TORQUES table and has no torque value provided on an associated installation drawing or service letter, use AC43.13-1B standard torque value tables shown below.

Use caution when tightening bolts in shear that are subject to rotational movement. The nut should be run down to washer or bearing surface snugly and must NOT be over torqued. Over torquing may cause deformation of the connection to a degree likely to result in binding or unnecessary wear.

### NON-STANDARD TORQUES

ASSEMBLY P/N	DESCRIPTION	FASTENER P/N	TORQUE (IN-LBS)
13A04000-127 (40-101)	Main Wheel Assembly (Cleveland)	AN4-40A	90
30-67C	Brake Assembly (Cleveland)	103-11700	85-90
13A06000-015 (40-426)	Nose Wheel Assembly (Cleveland)	AN5-35A	150
13A04000-127 (100-1024)	Main Wheel Assembly (Grove)	AN4-40A	90
13000A	Installation of Nose Fork/Spring Assembly to Nose Box	AN8-30A	500
		AN7-30A	400
13A06000-016	Nose Fork/Spring Assembly at Lower Spring Bolts	AN7-24A	400
13A04000-057	Main Gear Drag Link Assembly Brake Torque Plate Bolts	MS16997-99	190
	Main Gear Drag Link Assembly Lower Tube Bolts	AN7-13A	450
	Main Gear Drag Link Assembly Upper Tube Bolts	AN8-14A	490
1011359	Hydraulic Reservoir Sight Glass	MS21044N8	60

**STANDARD TORQUES PER AC43.13-1B**

<b>**TENSION APPLICATION—FINE THREAD</b>		
<b>NUT-BOLT SIZE</b>	<b>TORQUE LIMITS IN-LBS</b>	
	<b>MIN.</b>	<b>MAX.</b>
8-36	12	15
10-32	20	25
1/4-28	50	70
5/16-24	100	140
3/8-24	160	190
7/16-20	450	500
1/2-20	480	690
9/16-18	800	1000
5/8-18	1100	1300
3/4-16	2300	2500
7/8-14	2500	3000
1-14	3700	5500
1 1/8-12	5000	7000
1 1/4-12	9000	11000

<b>**SHEAR APPLICATION—FINE THREAD</b>		
<b>NUT-BOLT SIZE</b>	<b>TORQUE LIMITS IN-LBS</b>	
	<b>MIN.</b>	<b>MAX.</b>
8-36	7	9
10-32	12	15
1/4-28	30	40
5/16-24	60	85
3/8-24	95	110
7/16-20	270	300
1/2-20	290	410
9/16-18	480	600
5/8-18	600	780
3/4-16	1300	1500
7/8-14	1500	1800
1-14	2200	3300
1 1/8-12	3000	4200
1 1/4-12	5400	6600

\*\* A Torque of 80% should be used when Tef-Gel is applied to the bolt.

THIS PAGE INTENTIONALLY LEFT BLANK

## APPENDIX A - FLOAT INSTALLATION AND REMOVAL

### CONTENTS

A.1 FLOAT INSTALLATION.....	62
A.2 FLOAT REMOVAL.....	64

## A.1 FLOAT INSTALLATION

Registration #	
Job	
Date	
Aircraft S/N	
Float S/N	
Work Order	

Description	Mechanic	Inspector
Inventory stowable items.		
Attach all ground handling ropes as needed.		
Install finlets P/N 7D1-4120.		
Install cable stair door P/N 7B1-3018.		
Install lever servo rudder tab P/N 7B1-3017.		
Install elevator feel spring P/N 7B1-3014.		
Verify all placards. <b>Note:</b> See 7C1-3002.		
Adjust control surface travels. <b>Note:</b> See 7C1-3002 for travels and modification.		
Adjust stall speed vane. <b>Note:</b> See 7C1-3002.		
Re-mark airspeed indicator markings (KIAS). <b>Note:</b> See 7C1-3002. Perform APEX airspeed programming instructions (-400 only). <b>Note:</b> See 1004383.		
Position aircraft under hoist.		N/A
Inspect lifting rig.		N/A
Remove wing gap strips.		N/A
Connect lifting bar to hoist.		N/A
Remove wing gap strips and attach hoist (make sure correct lift point fittings are in correct position).		
Lift aircraft to ensure it hangs level. <b>Note:</b> Add ballast if required.		N/A
Lower aircraft until all wheels are barely touching ground.		N/A
Tie ropes to all tie downs.		N/A
Install forward strut fitting using new barrel nuts P/N 2552-064.		
Remove main gear fairings.		N/A
Remove nose wheel last.		N/A
Lift aircraft and remove main gear.		N/A
Remove forward steps in fuselage. <b>Note:</b> Ops Only		
Assemble support crew (3 people).		N/A
Move floats into position.		N/A



## A.2 FLOAT REMOVAL

**Note:** Refer to blueprints.

Registration #	
Job	
Date	
Aircraft S/N	
Float S/N	
Work Order	

Description	Mechanic	Inspector
Attach lift rig to hoist and position aircraft.		
Remove wing gap strips and attach hoist. <b>(Make sure correct lift point fittings are in correct position).</b>		
Remove fairings as needed.		
Disconnect, plug, mark and secure hydraulic fittings and lines at airframe to float connection point.		
Disconnect, secure and mark electrical connections at airframe to float connection point.		
Attach all ground handling ropes as needed.		
Remove step struts.		
Remove float hydraulic powerpack in nose gear well.		
Install noise landing gear assembly and secure.		
Re-install nose steering mechanism.		
Lift aircraft and stabilize close to level.		
With weight removed from floats, relieve tension and disconnect fly wires.		
Loosen main gear pylon attach hardware, aft kicker strut.		
Identify position of all installed bushings and shims at attach points and bag for future reinstall.		
Remove fly wire pulls off aircraft if needed.		
Disconnect all main pylon and forward attach points.		
Move floats away and position main gear for install.		
Ensure landplane gear is serviced and airworthy per DHC-6 maintenance manual.		
Install main gear per DHC-6 maintenance manual procedure.		
Attach break lines and bleed brakes and service reservoirs per DHC-6 maintenance manual.		
Install all main gear fairings and nose gear close out panels.		
Install landplane air stair door cables.		
Remove finlets and plug attach points.		
Reposition stall switch for landplane operations.		
Reset rudder travel to landplane setting, reference DHC-6 maintenance manual.		
Remark airspeed indicator for landplane operations. Perform APEX airspeed programming instructions (-400 only) floatplane to landplane configuration. <b>Note:</b> See 1004383		

SERVICE MANUAL & ICA  
 WIPLINE 13000 FLOATS

Description	Mechanic	Inspector
Remove elevator feel springs.		
Re-install rudder servo tab landplane actuator arm.		
Remove all ground handling ropes.		
Remove right hand winf leading edge stall strip. Strip may remain if aircraft is modified per STC SA100CH (-34 Engine).		
Complete findal walkaround.		
Verify valid landplane weight and balance report in POH or ships papers.		
Verify POH supplement for floats is current and available.		
<b>Notes:</b>          		

This checklist is derived from the requirements of the appropriate aircraft, engine and component manufacturers maintenance manuals, service publications and STC instructions for continued airworthiness.