

WIPAIRE, INC.  
INVER GROVE HEIGHTS, MN

SERVICE KIT: #19

DATE: 11/25/2019

SUBJECT: CONVERSION OF MODEL 6000 TO MODEL 6100 FLOAT

MODELS EFFECTIVE: Model 6000 seaplane and amphibious floats, used in 6000 lb. gross weight applications on DHC-2 Mk III Aircraft.

<u>Item</u>	<u>Quantity</u> <u>Per Float</u>	<u>Part No.</u>	<u>Description</u>
1.	1	6A01163-042	Cover
2.	2	6A01156-114	Strip
3.	1	6P01158-157	Cover
4.	1	3A01650-002	Cup
5.	1	3A01158-005	Ring
6.	1	20.5"	Pumpout Tube
7.	1	SNP-16	Clamp
8.	1	3A01158-003	Clamp
9.	14	#8 X 3/4	Screws
10.	6	9A3-671 (2 Hole)	Nut Plates
11.	2	9A3-671 (1 Hole)	Nut Plates
12.	A/R	AN426AD4-5	Rivets
13.	A/R	AN470AD4-5	Rivets
14.	1	26A04000-014	Ass'y Shock Strut
15.	1	19B3-138-7L	Left I.D. Plate
16.	1	19B3-138-7R	Right I.D. Plate
17.	1		Template
18.	1	No. 33	Service Letter

NOTE:

1. Return to factory Model 6000 left and right identification plates from floats. Install new I.D. plates for 6100 floats when received from factory.
2. Amphibian only. Remove existing shock strut and return to factory for modification or exchange.
3. Install above parts per installation drawing 5C1-789.

**INSTRUCTIONS**

1. DRILL OUT ALL RIVETS IN TOP SKIN ANGLES APPROX. 11.375 AND 17.125 AFT FACE OF NOSE BULKHEAD.
2. CENTER TEMPLATE ON TOP-SKIN CENTERLINE.
3. LAYOUT 5" X 12.25" HOLE ON TOP-SKIN AND CUT OUT BETWEEN STIFFENERS.
4. MATCH DRILL  $\phi$  #10 HOLES FROM TEMPLATE THRU TOP SKIN AND TOP SKIN ANGLES FOR COVER ATTACH HOLES,  $\phi$  #30 HOLES FOR NUTPLATE ATTACH.
5. COUNTERSINK ALL REMAINING HOLES IN TOP-SKIN AND INSTALL AN426AD4 RIVETS.
6. INSTALL 6A01156-114 STRIP UNDER SKIN BEFORE INSTALLING 9A3-671 NUTPLATES.
7. LOCATE  $\phi$  1.75 PUMP-OUT CLIP HOLE FROM TEMPLATE AND INSTALL 3A01650-002 CUP, 3A01650-002 RING, RIVET TO TOPSKIN.
8. INSTALL 3A01158-003 CLAMP ON FWD SIDE OF # 3 BULKHEAD, APPROX. 3" UP FROM KEEL.
9. INSTALL PUMP-OUT TUBE (20.5"). SECURE TOP OF TUBE TO PUMP-OUT CLIP WITH SNP-16 CLAMP.
10. INSTALL 9A3-671 NUTPLATES AND INSULATORS TO INSIDE OF TOPSKIN ANGLES WITH AN426AD4 RIVETS.
11. SEAL COMPLETELY AROUND #3 BULKHEAD. WATER CHECK AFTER SEALING.
12. IF AMPHIBIOUS FLOAT, SEAL AROUND NOSE BDX AT #3 BULKHEAD. IF SEALPLANE FLOAT, INSTALL 6P01158-157 COVER OVER NOSEBOX HOLE IN #3 BULKHEAD. MATCH DRILL AND SECURE WITH AN470AD4 RIVETS.
13. APPLY CAULKING AROUND CUTOUT AND ATTACH 6A01163-042 COVER WITH #8 X 3/4" SCREWS (14).
14. AMPHIBIAN FLOATS, REMOVE EXISTING MODEL 6000 SHOCK STRUTS AND REPLACE WITH WIPAIRE P/N 6A04000-014 MODEL 6100 STRUTS.

REVISIONS		
REV	DESCRIPTION	DATE

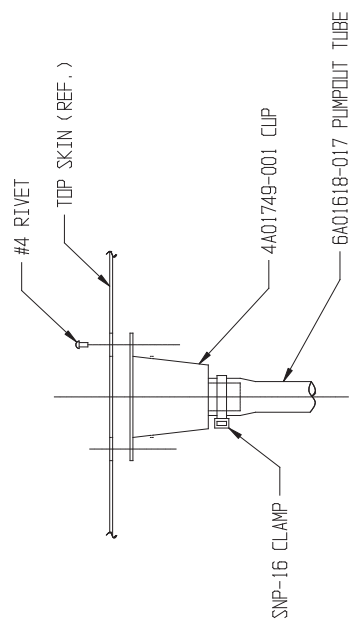
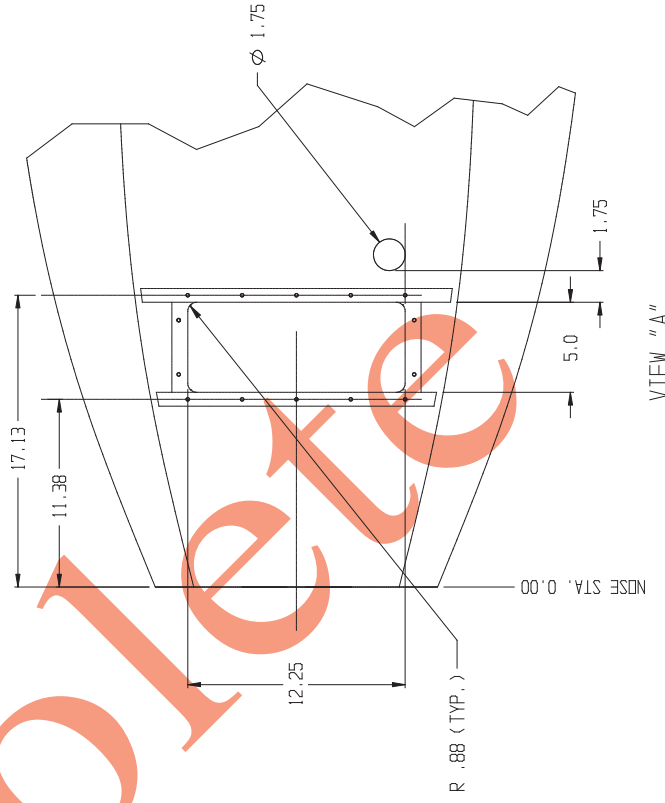
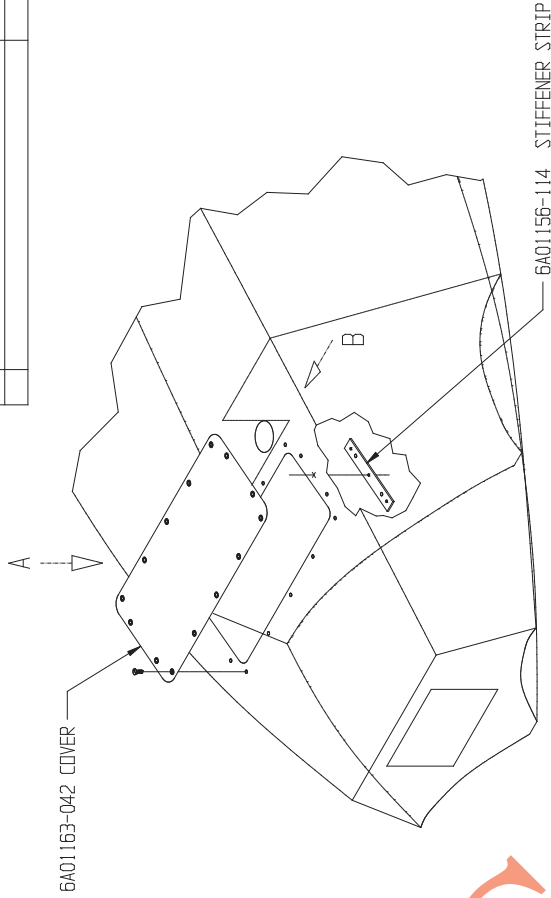

MAT'L	WIPAIRE INC		
FINISH	8520 RIVER ROAD, INVER GROVE HEIGHTS, MN. 55076		
NAME	DATE	TOLERANCES	TITLE
W GLEN	08/16/94	.00 ± .015	INSTALLATION INSTRUCTIONS, KIT #19
DR		.000 ± .005	SCALE
APPD			NONE
			PROJ. NO.
			5C1-789
			REV