



- MANUFACTURERS OF WIPLINE FLOATS & SKIS
- SPECIALISTS IN AIRCRAFT MODIFICATION

1700 Henry Avenue - Fleming Field
South St. Paul, MN 55075
651-451-1205

SERVICE LETTER: 76

DATE: July 18, 2024

TITLE: AT-802 Fire Boss Finlet Inspection & Repair

EFFECTIVITY: **AT-802 w/ Fire Boss conversion, all serial numbers, comply with finlet inspection within the next 20 hours of flight time.**

BACKGROUND INFORMATION: AT-802 with Fire Boss modifications have been experiencing cracking along the weld on the front bracket that holds the finlet onto the horizontal stabilizer. Thus far the cracks have been limited to the early model conversions. Corrosion in this area may have been a factor.

METHOD OF COMPLIANCE: **On both the top and bottom finlets:**

Visually inspect the welded seam of the finlet's forward attach bracket (p/n 10A12000-070) for cracks along the weld. Fax or email results of inspection as noted below. Pictures may be helpful to Wipaire Engineering.

If any crack or corrosion is found on the fitting and is less than .6 centimeters (1/4 inch), there are 2 options of compliance.

Option 1: Mark the end and re-inspect every 10 hours for propagation.

If there is propagation, replace the bracket as soon as practical or re-weld as per Option 2.

Option 2: Remove the bracket from the finlet using the directions included for field replacement in Service Kit 55. Remove all finish from the bracket. Clean and re-weld crack area and continue the weld all the way around the bracket, as shown in Figure 2, as per FAR 43.13. Stress relieve the bracket and re-prime and paint for corrosion protection.

If crack or corrosion is longer than .6 centimeters (1/4 inch), field replacement of the bracket will be necessary. Detailed procedures are listed in Service Kit 55 for the field Replacement of the bracket.

MAN HOURS REQUIRED: 1 Hour for inspection – 3 hours for bracket welding.

WARRANTY: Parts and labor for 18 months past the original date of this service letter.

PARTS REQUIRED: Parts included with Service Kit 55.

NOTE:
After the inspection is complete, send results
Including aircraft serial number to
Wipaire Chief Engineer, Chuck Wiplinger.
Fax 651-451-1786 Attention Chuck
Or
cwiplinger@wipaire.com

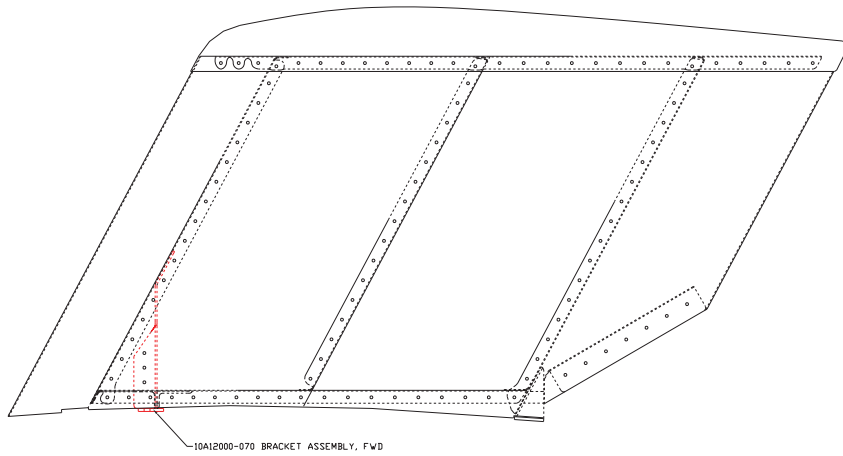
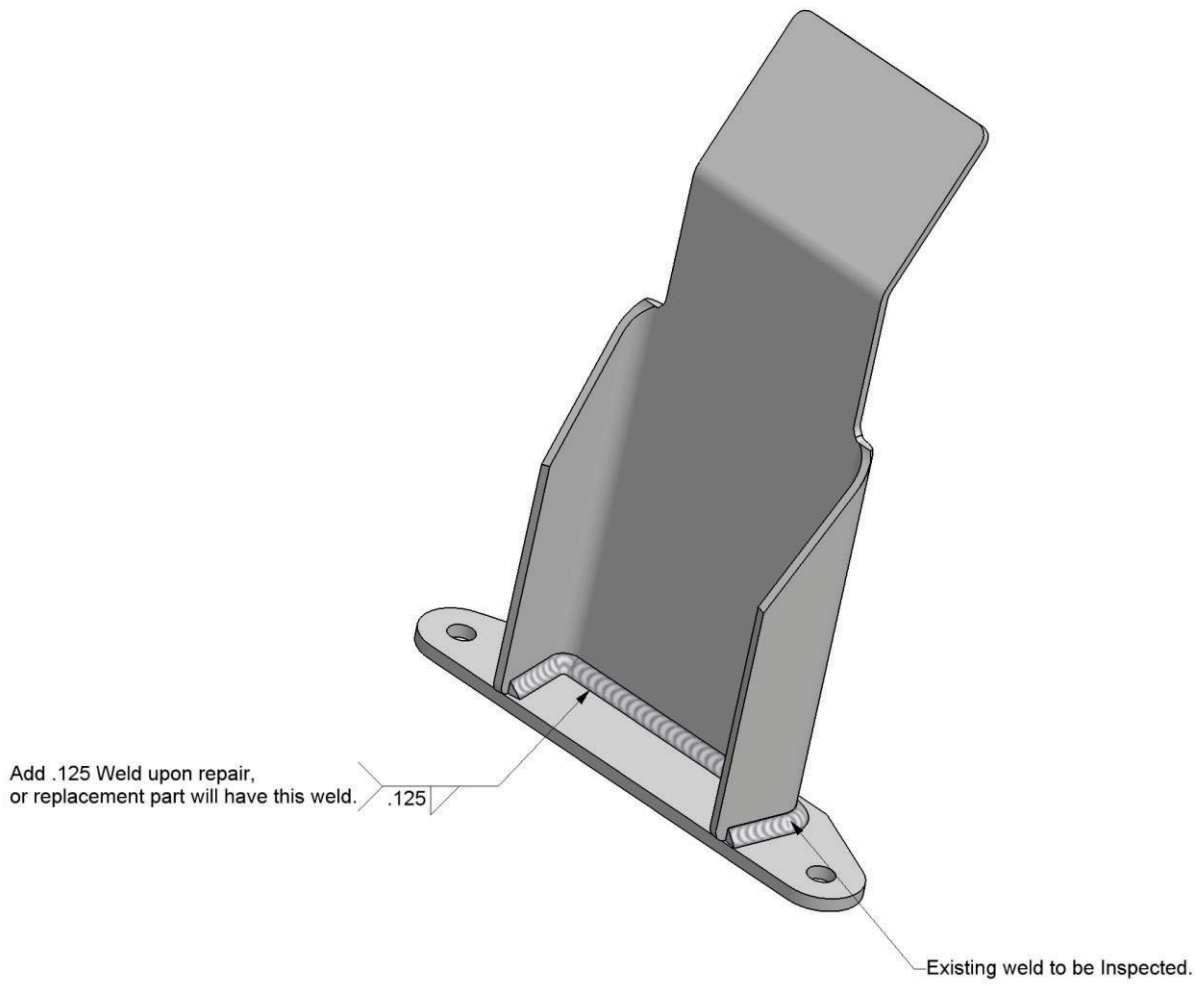

Figure 1

Discontinued...Sup

vice Letter 253



Discontinued.....

Figure 2