



WIPLINE FLOATS • SKIS • MODIFICATIONS • AIRCRAFT SALES
AVIONICS • INTERIOR • MAINTENANCE • PAINT REFINISHING



**PARTS MANUAL
FOR
WIPLINE MODEL 2100 FLOATS
ON
CESSNA 170**

Revision J

1700 Henry Ave. - Fleming Field (KSGS), South St. Paul, MN 55075
Ph: 651.451.1205 Fax: 651.457.7858
www.wipaire.com

THIS PAGE INTENTIONALLY LEFT BLANK

LOG OF REVISIONS

Revision	Pages Affected	Description	Date
A	All	Initial Release	8/25/2010
B	All	Reformatted entire manual, update to Part Sales Dept page, added new warranty and customer information, updated hyd. pump, gear selector, strut, step, steering/retract, wires and spreader bar, electrical schematic images and BOMS, corrected multiple clerical errors and incorrect part/item callouts, added Grove Nose wheel, washer 415067 was 359071.	5/28/2013
C	3	Removed Warranty Claim Form.	3/31/2016
D	10, 14, 16, 19-20, 42, 44, 46, 53-54, 57, 72-75, 77-83, 89, 91, 93	Updated skins in Amphibian and Seaplane Hull Assembly drawings and part numbers. Changed 21A01000-275 to Assembly Spray Rail R. and 21A01000-274 to Assembly Spray L. in Seaplane Hull Assembly. Added Item 32 in Lower Nose Gear Assembly drawing and added Plate – Bearing, Nose Spring and hardware part numbers. Changed Bolt AN4-13A to NAS6204-17 in Main Gear Retraction. Changed Nut H10-4 to NAS679A4W and changed H10-3 to NAS679A3W in Retract Handle Assembly. Changed Bolt AN5-11A to Clevis Magnet 1005875. Changed Switch Screw MS35206-215 to MS24693-S6. Updated Pad 66-111 to 066-111 and Rivet 105-2 to 066-001 in Main Gear Wheel Grove section. Updated Hydraulic System Installation drawing and part numbers. Updated Hydraulic Pump drawings and part numbers. Removed part numbers for 24V pump.	11/4/2019
E	All	Reformatted manual in new software. Updated sections and created new drawings for bulkhead assemblies. Created sections for skins. Added 3A07005-178 Clip, Switch, Nose & Main to Nose Gear Retraction Assembly. Updated drawing for Gear Control (Rectangle) and the parts list. Changed Bushing 1001011 to 1001100 in Main Gear Retraction. Updated part numbers in Grove/Wipaire and Cleveland/Parker Main Wheel sections.	6/1/2020
F	13, 37, 40, 42-44, 74, 76, 81, 83-84, 101	Changed 21A01158-203 to 21S01158-203. Updated bottom skins and stiffeners. Added note about nose and main gear tire/tube. Updated Tire part number to AA1D4 and Tube part number to XA1AC. Added note about Wipaire drawing 1011065 for alternate part numbers.	5/10/2021
G	All	Changed 010-026 Seal to 471570 Seal, Timken. Added sections for Pre/Post Service Letter 233 for hydraulics and electrical. Updated Hydraulic System Installation image and parts list. Added Hydraulic Pump Assembly 1011887 image and parts list. Updated Hydraulic Pump Overview image and parts list. Updated Electrical Schematic image and parts list. Updated Hydraulic & Brake Schematic image and parts.	2/14/2022
H	60, 80-81	Updated Pump Out Cup and Valve image and parts. Updated image and parts list for Main Gear Wheel Grove/Wipaire Assembly section.	1/30/2023
J	120, 122	Corrected bulb part numbers in gear control indicator assemblies.	9/23/2024

View most current version of parts manual at www.wipaire.com.

THIS PAGE INTENTIONALLY LEFT BLANK

CONTENTS

FLOAT PART SALES DEPARTMENT OPERATIONS	6
INTRODUCTION	7
SECTION 1 HULL BULKHEAD ASSEMBLIES	9
SECTION 2 WHEEL WELL ASSEMBLY	31
SECTION 3 SKINS & STIFFENERS	35
SECTION 4 TOP DECK ASSEMBLY	45
SECTION 5 EXTRUSIONS	53
SECTION 6 PUMPER TUBE INSTALLATION	59
SECTION 7 WATER RUDDER & RETRACT HANDLE	61
SECTION 8 LANDING GEAR	67
SECTION 9 STRUTS, STEPS, STEERING / RETRACT, WIRES AND SPREADER BARS	85
SECTION 10 HYDRAULIC SYSTEM	91
SECTION 11 ELECTRICAL	113

FLOAT PART SALES DEPARTMENT OPERATIONS

Parts Sales:

Wipaire, Inc.

1700 Henry Avenue – Fleming Field

South St. Paul, MN 55075

Telephone: (651) 306-0459

Fax: (651)-306-0666

Website: www.wipaire.com

Email: customerservice@wipaire.com

Note: Any information not found in this manual for strut package parts and other installation items refer to the installation drawing package provided with the STC at the time of float installation. Additional drawing copies are available for purchase through the Wipaire Customer Service Department.

Parts Ordering

Purchase orders should include:

1. Purchase order number
2. Name of person placing order
3. Invoicing information:
 - a. Customer name - company or individual
 - b. Address
 - c. Phone and fax number
4. Shipping information:
 - a. Address (if different from invoice address)
 - b. Method of shipment/preferred carrier
5. Aircraft model, float model, and serial numbers
6. Wipaire part number; name; type, e.g. left or right; quantity
7. Payment method: VISA, MasterCard, C.O.D. (Collect on Delivery) (U.S. customers only), pre-payment by check or wire transfer, open account (see Credit Policy)

INTRODUCTION

All references in this manual to LEFT and RIGHT are from the perspective of the pilot's seat with the floats fully installed and ready for floatplane operation.

The following is a list of abbreviations that may appear in the description nomenclature fields of this manual:

AB	Afterbody	Inbd.	Inboard
Amphib.	Amphibious	Lg.	Large
AR	As Required	Lt.	Left
Assy.	Assembly	Lwr.	Lower
Brkt.	Bracket	Opt.	Optional
Btm.	Bottom	Otbd.	Outboard
Bulk.	Bulkhead	Reinf.	Reinforcement
Ctr.	Center	Rr.	Rear
Cyl.	Cylinder	Rt.	Right
Ft.	Front	Sm.	Small
Ftg.	Fitting	SN	Serial Number
Fus.	Fuselage	Spr.	Spreader
Fwd	Forward	Up.	Upper
Horiz.	Horizontal	Vert.	Vertical
Hyd.	Hydraulic	W.W.	Wheel Well

USING THIS PARTS MANUAL

COVERAGE

Parts information is provided in this manual for the hulls and all "deck down" parts. For information on strut package parts and other aircraft installation items, refer to the installation drawing package provided with the STC at the time of float installation. Additional drawing copies are available for purchase through Wipaire Customer Service Department.

Name of main part in the section. Example: This part is showing the components made up in Bulkhead #1.

BULKHEAD #1

Main part image. If the image has numbers associated with it, then those numbers are item numbers shown in the table below.

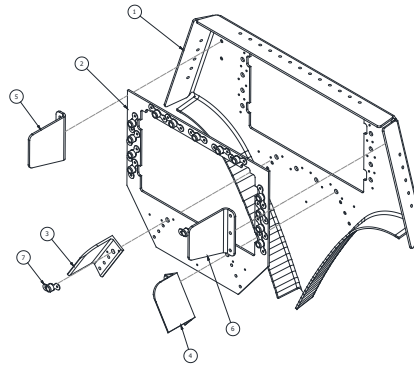

Items with a (-) instead of a number represent the main part as an assembly. Other parts represent the parts included in the assembly.

ITEM	QTY	PART NO.	PART DESCRIPTION
-	1	1008815	ASSEMBLY BULKHEAD #1, 10000
1	1	1008797	PANEL, BULKHEAD #1
2	1	13A01156-085	DOUBLER #1 BULKHEAD
3	1	13A01357-049	CLEAT, SISTER KEEL ATTACH #1 BULKHEAD
4	1	13A01357-050	CLEAT, SISTER KEEL ATTACH #1 BULKHEAD
5	1	6A01156-054	ANGLE – TOP RAIL
6	1	6A01156-055	ANGLE – TOP RAIL
7	17	MS21047L4	NUT PLATE, SELF LOCKING

To order an individual part, order the part number associated with item number.

SECTION 1 HULL BULKHEAD ASSEMBLIES

CONTENTS

HULL ASSEMBLY - AMPHIBIAN.....	10
HULL ASSEMBLY - SEAPLANE	12
NOSE BUMPER - AMPHIBIAN	15
BULKHEAD #1.....	16
BULKHEAD #3.....	17
BULKHEAD #4.....	18
BULKHEAD #5.....	19
BULKHEAD #6.....	20
BULKHEAD #7 LEFT FLOAT	21
BULKHEAD #7 RIGHT FLOAT	22
BULKHEAD #8 LEFT FLOAT	23
BULKHEAD #8 RIGHT FLOAT	24
BULKHEAD #10.....	25
BULKHEAD #11.....	26
BULKHEAD #12.....	27
BULKHEAD #13.....	28
BULKHEAD #14.....	29

HULL ASSEMBLY - AMPHIBIAN

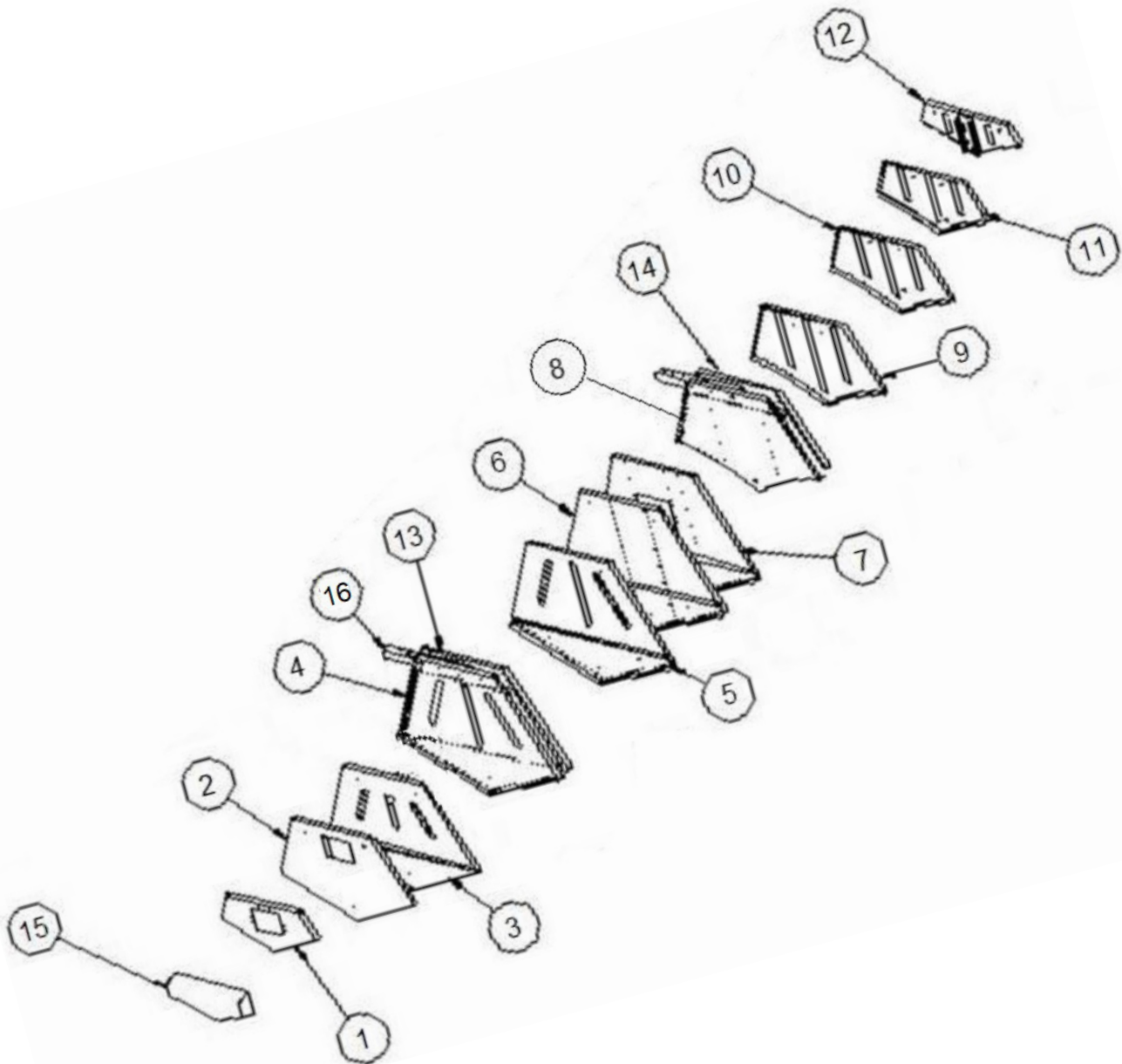

PARTS MANUAL
2100 FLOATS ON CESSNA 170

ITEM	QTY	PART NO.	PART DESCRIPTION
1	1	21A01163-067	ASSEMBLY, BULKHEAD #1
2	1	21A01000-265	ASSEMBLY, BULKHEAD #3
3	1	21A01000-261	ASSEMBLY, BULKHEAD #4
4	1	21A01000-253	ASSEMBLY, BULKHEAD #5
5	1	21A01000-252	ASSEMBLY, BULKHEAD #6
6 LT.	1	21A01000-267	ASSEMBLY, BULKHEAD #7, LH
6 RT.	1	21A01000-266	ASSEMBLY, BULKHEAD #7, RH
7 LT.	1	21A01000-263	ASSEMBLY, BULKHEAD #8, LH
7 RT.	1	21A01000-264	ASSEMBLY, BULKHEAD #8, RH
8	1	21A01000-262	ASSEMBLY, BLKHD 10, COMP
9	1	21A01000-395	ASSEMBLY, BULKHEAD #11
10	1	21A01000-396	ASSEMBLY, BULKHEAD #12
11	1	21A01000-397	ASSEMBLY, BULKHEAD #13
12	1	21A01000-250	ASSEMBLY, BULKHEAD #14
13	1	21A01000-260	ASSY. SPR. BAR PANEL FWD
	1	21A01163-065	PANEL – SPR. BAR
	1	21A01326-013	ANGLE – SIDE L.
	1	21A01326-014	ANGLE – SIDE R.
	1	AN4-5A	BOLT, 1/4-28, 0.1875 GRIP, UNDRILLED, STEEL
	1	NAS1149F0463P	WASHER, 0.265 ID, 0.063 THK, STEEL
	1	MS21044N4	NUT, LOCKING, REGULAR HEIGHT, 1/4-28 UNF
14	1	21A01000-259	ASSY. SPR. BAR PANEL AFT
	1	21A01163-065	PANEL – SPR. BAR
	1	21A01326-009	ANGLE – SIDE L.
	1	21A01326-010	ANGLE – SIDE R.
	1	AN4-5A	BOLT, 1/4-28, 0.1875 GRIP, UNDRILLED, STEEL
	1	NAS1149F0463P	WASHER, 0.265 ID, 0.063 THK, STEEL
	1	MS21044N4	NUT, LOCKING, REGULAR HEIGHT, 1/4-28 UNF
15	1	21A01000-295	ASSEMBLY, NOSE BUMPER, 2100
16	2	21A03115-001	TUBE – SPR. BAR MOUNTING
	6	AN4-22A	BOLT, 1/4-28, 1.8125 GRIP, UNDRILLED, STEEL
	12	NAS1149D0416J	WASHER, 0.265 ID, 0.016 THK, ALUMINUM
	12	NAS1149D0463J	WASHER, 0.265 ID, 0.063 THK, ALUMINUM
	6	MS21044N4	NUT, LOCKING, REGULAR HEIGHT, 1/4-28 UNF

HULL ASSEMBLY - SEAPLANE

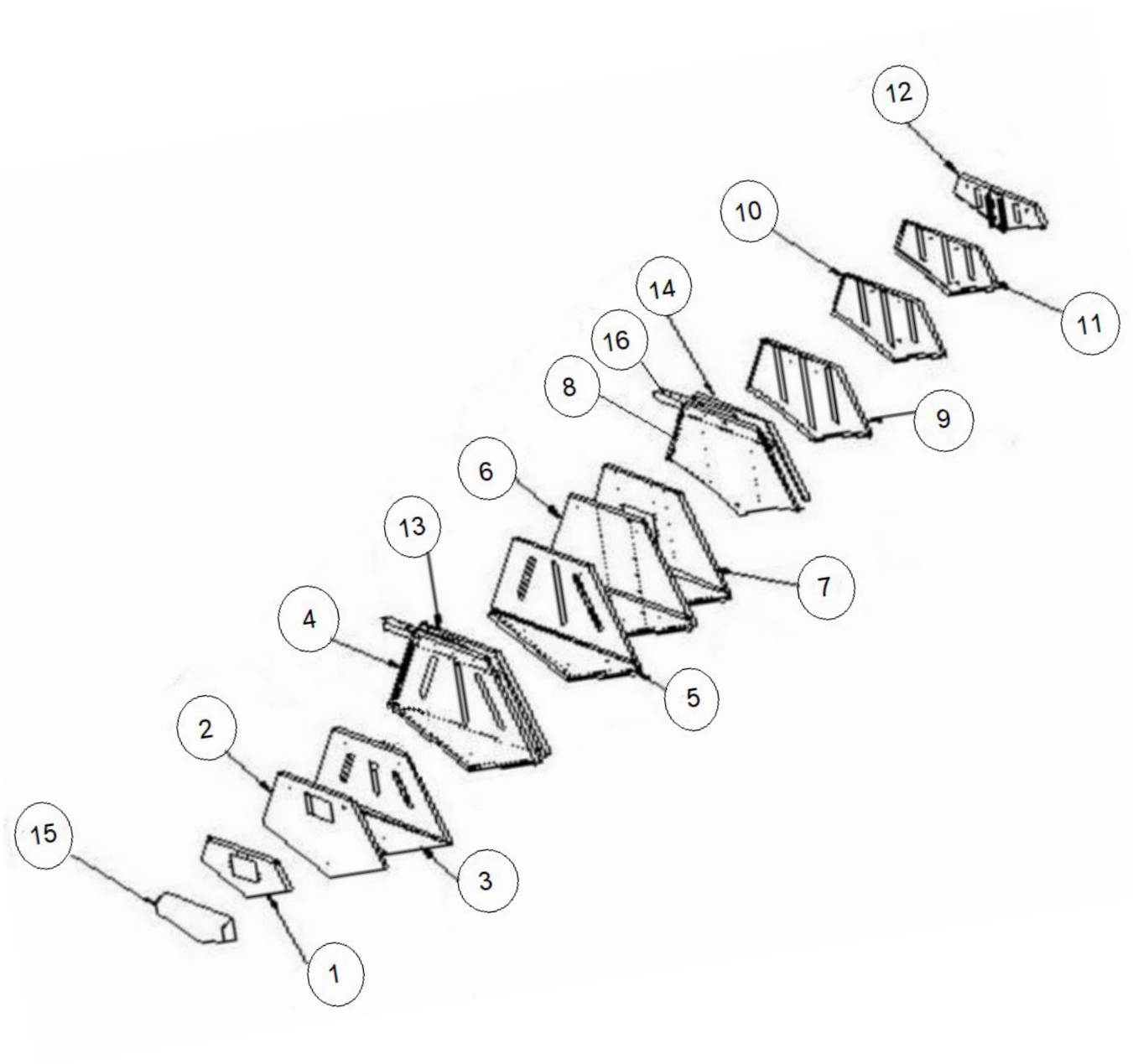

PARTS MANUAL
2100 FLOATS ON CESSNA 170

ITEM	QTY	PART NO.	PART DESCRIPTION
1	1	21A01163-067	BULKHEAD #1
	1	21S01150-134	COVER – NOSE GEAR OPENING
	A/R	MS21059L3	PLATE NUT
2	1	21A01000-265	ASSY BULKHEAD #3
	1	21A01158-184	BULKHEAD
	1	21A01326-006	ANGLE – NOSE BOX ATTACH
	1	21A01326-005	ANGLE – NOSE BOX ATTACH
3	1	21A01000-261	ASSY BULKHEAD #4
	1	21A01158-174	BULKHEAD – MAIN
	1	21A01158-175	SUPPORT – BULKHEAD LOWER
	1	3A01158-003	CLAMP, PUMP OUT TUBE
4	1	21A01000-253	ASSY BULKHEAD #5
	1	21A01158-178	BULKHEAD - MAIN
	1	21A01326-007	ANGLE – SIDE L.
	1	21A01326-008	ANGLE – SIDE R.
	1	21A01163-066	PANEL – SPR. BAR
	1	21A01158-177	SUPPORT – BULKHEAD LOWER
	1	3A01158-003	CLAMP, PUMP OUT TUBE
5	1	21A01000-252	ASSY BULKHEAD #6
	1	21A01158-189	BULKHEAD – MAIN
	1	21A01158-177	SUPPORT – BULKHEAD LOWER
	1	MS35489-19	GROMMET
6	1	21S01000-308	ASSY BULKHEAD #7
	1	21A01158-189	BULKHEAD - MAIN
	1	21A01158-177	SUPPORT – BULKHEAD LOWER
	1	3A01158-003	CLAMP, PUMP OUT TUBE
7	1	21S01000-309	ASSY BULKHEAD #8
	1	21A01158-189	BULKHEAD – MAIN
	1	21A01158-177	SUPPORT – BULKHEAD LOWER
	2	21S01158-203	ANGLE – A.B. SKIN ATTACH
	1	3A01158-003	CLAMP, PUMP OUT TUBE
8	1	21S01000-322	ASSY. – BULKHEAD #10
	1	21A01158-169	BULKHEAD - MAIN
	1	21A01326-011	ANGLE SIDE L.
	1	21A01326-012	ANGLE SIDE R.
	1	21A01163-066	PANEL – SPR. BAR
	2	21S01340-129	ANGLE – VERTICAL
	1	3A01158-003	CLAMP, PUMP OUT TUBE
9	1	21A01000-395	BULKHEAD #11
	1	21A01158-168	BULKHEAD PANEL
10	1	21A01000-396	BULKHEAD #12

ITEM	QTY	PART NO.	PART DESCRIPTION
	1	21A01158-167	BULKHEAD PANEL
11	1	21A01000-397	BULKHEAD #13
	1	21A01158-166	BULKHEAD PANEL
12	1	21A01000-250	ASSY. BULKHEAD #14
	1	21A01158-164	BULKHEAD - MAIN
	1	21A01158-165	CHANNEL – REIN.
	1	21A08156-130	PLATE – WATER RUDDER STOP
13	1	21A01000-260	ASSY. SPR. BAR PANEL FWD
	1	21A01163-065	PANEL – SPR. BAR
	1	21A01326-013	ANGLE – SIDE L.
	1	21A01326-014	ANGLE – SIDE R.
	1	AN4-5A	BOLT, 1/4-28, 0.1875 GRIP, UNDRILLED, STEEL
	1	NAS1149F0463P	WASHER, 0.265 ID, 0.063 THK, STEEL
	1	MS21044N4	NUT, LOCKING, REGULAR HEIGHT, 1/4-28 UNF
14	1	21A01000-259	ASSY. SPR. BAR PANEL AFT
	1	21A01163-065	PANEL – SPR. BAR
	1	21A01326-009	ANGLE – SIDE L.
	1	21A01326-010	ANGLE – SIDE R.
	1	AN4-5A	BOLT, 1/4-28, 0.1875 GRIP, UNDRILLED, STEEL
	1	NAS1149F0463P	WASHER, 0.265 ID, 0.063 THK, STEEL
	1	MS21044N4	NUT, LOCKING, REGULAR HEIGHT, 1/4-28 UNF
15	1	21S01738-001	NOSE BUMPER
16	2	21A03115-001	TUBE – SPR. BAR MOUNTING
	6	AN4-22A	BOLT, 1/4-28, 1.8125 GRIP, UNDRILLED, STEEL
	12	NAS1149D0416J	WASHER, 0.265 ID, 0.016 THK, ALUMINUM
	12	NAS1149D0463J	WASHER, 0.265 ID, 0.063 THK, ALUMINUM
	6	MS21044N4	NUT, LOCKING, REGULAR HEIGHT, 1/4-28 UNF

NOSE BUMPER - AMPHIBIAN

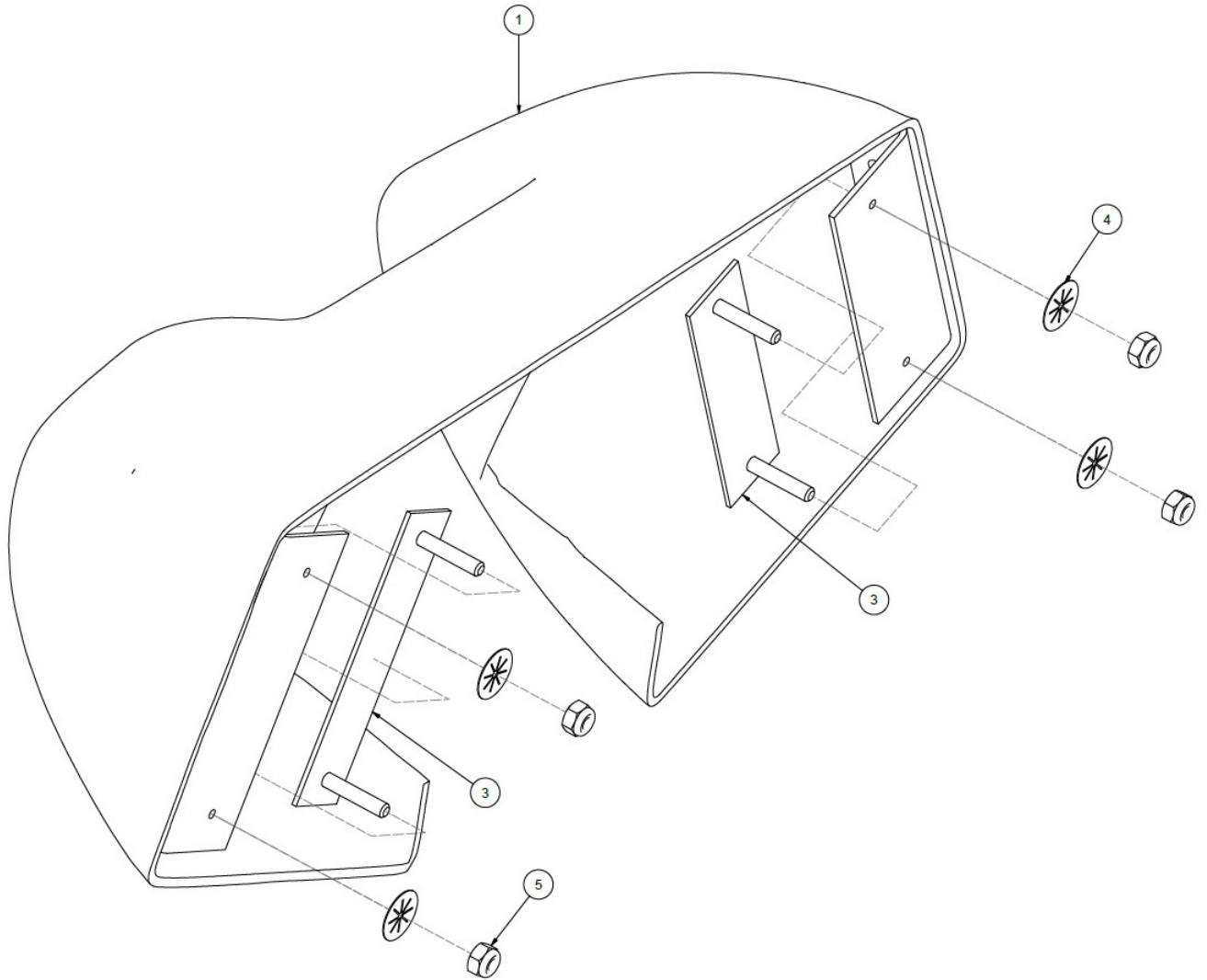

ITEM	QTY	PART NO.	PART DESCRIPTION
-	1	21A01000-295	ASSEMBLY, NOSE BUMPER, 2100
1	1	21A01000-295-1	NOSE BUMPER
2	2	21A01000-295-2	ANGLE, MOUNT, NOSE BUMPER
3	2	21A01000-295-3	PLATE, SCREW MOUNT, NOSE BUMPER
4	4	4HFW3	PUSH NUT WASHER
5	4	MS21044N3	NUT, LOCKING, REGULAR HEIGHT, 10-32 UNF
6	4	MS51958-67	SCREW, BUTTON HEAD

BULKHEAD #1

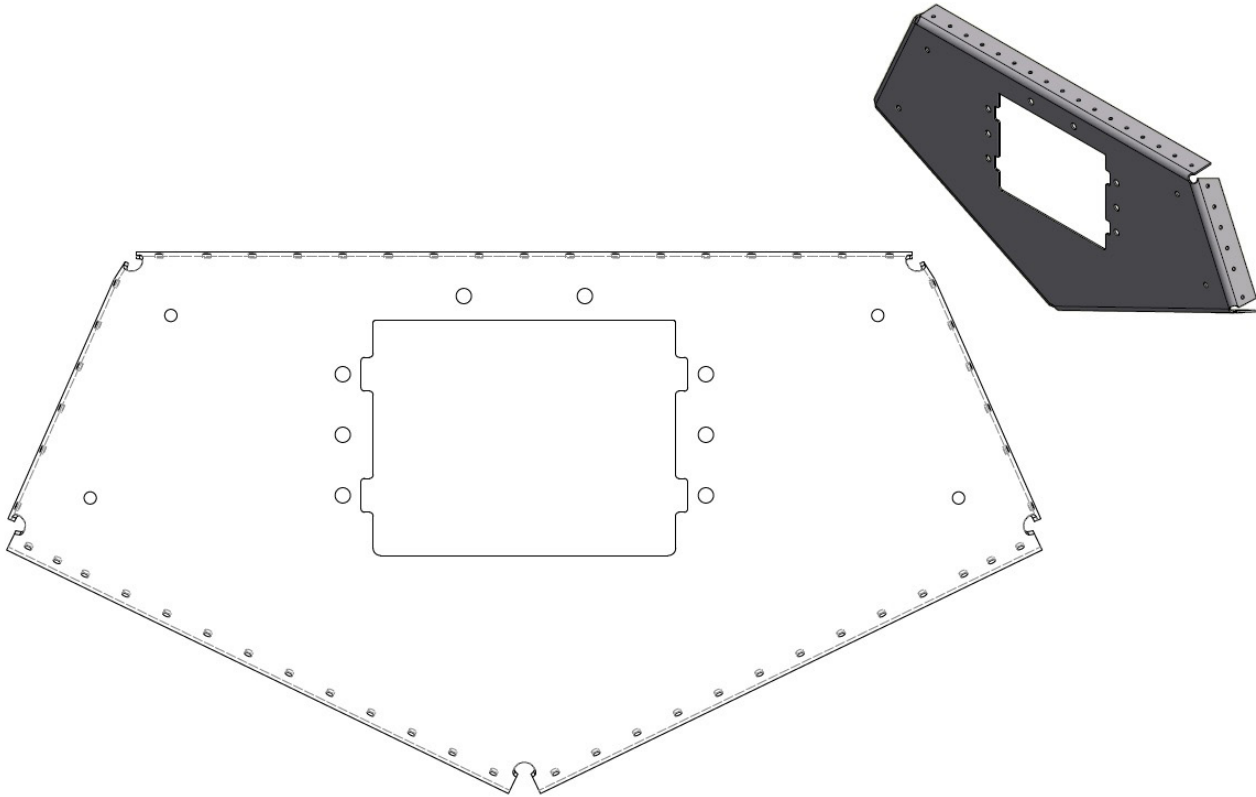

ITEM	QTY	PART NO.	PART DESCRIPTION
-	1	21A01163-067	BULKHEAD #1

BULKHEAD #3

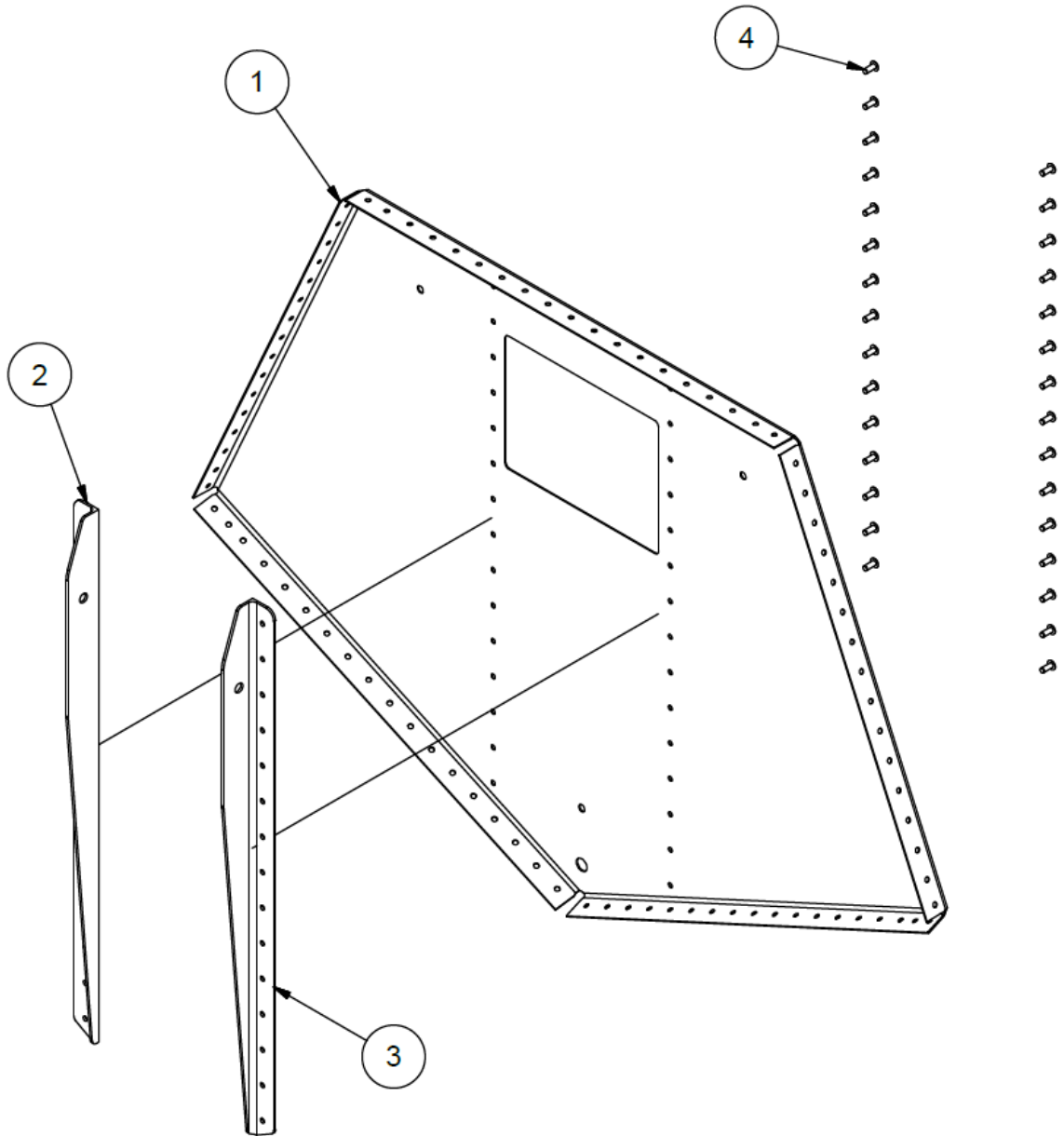

ITEM	QTY	PART NO.	PART DESCRIPTION
-	1	21A01000-265	ASSEMBLY, BULKHEAD #3
1	1	21A01158-184	BULKHEAD #3
2	1	21A01326-005	ANGLE, SUPPORT BULKHEAD #3 LT.
3	1	21A01326-006	ANGLE, SUPPORT BULKHEAD #3 RT.
4	30	AN470AD4-5	RIVET

BULKHEAD #4

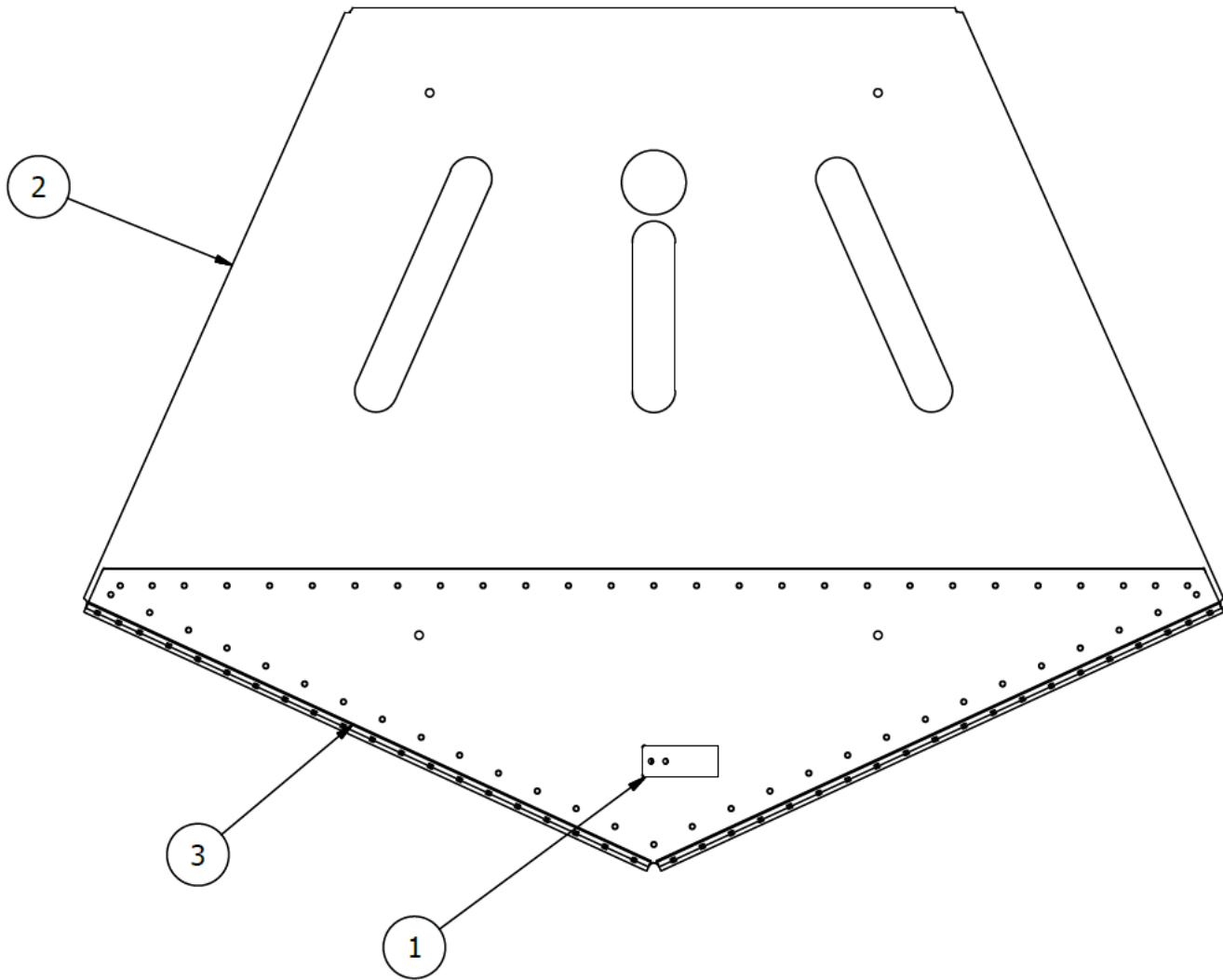

ITEM	QTY	PART NO.	PART DESCRIPTION
-	1	21A01000-261	ASSEMBLY, BULKHEAD #4
1	1	3A01158-003	CLAMP, PUMP OUT TUBE
2	1	21A01158-174	BULKHEAD #4 - FORMED
3	1	21A01158-175	BULKHEAD SUPPORT #4 - FORMED

BULKHEAD #5

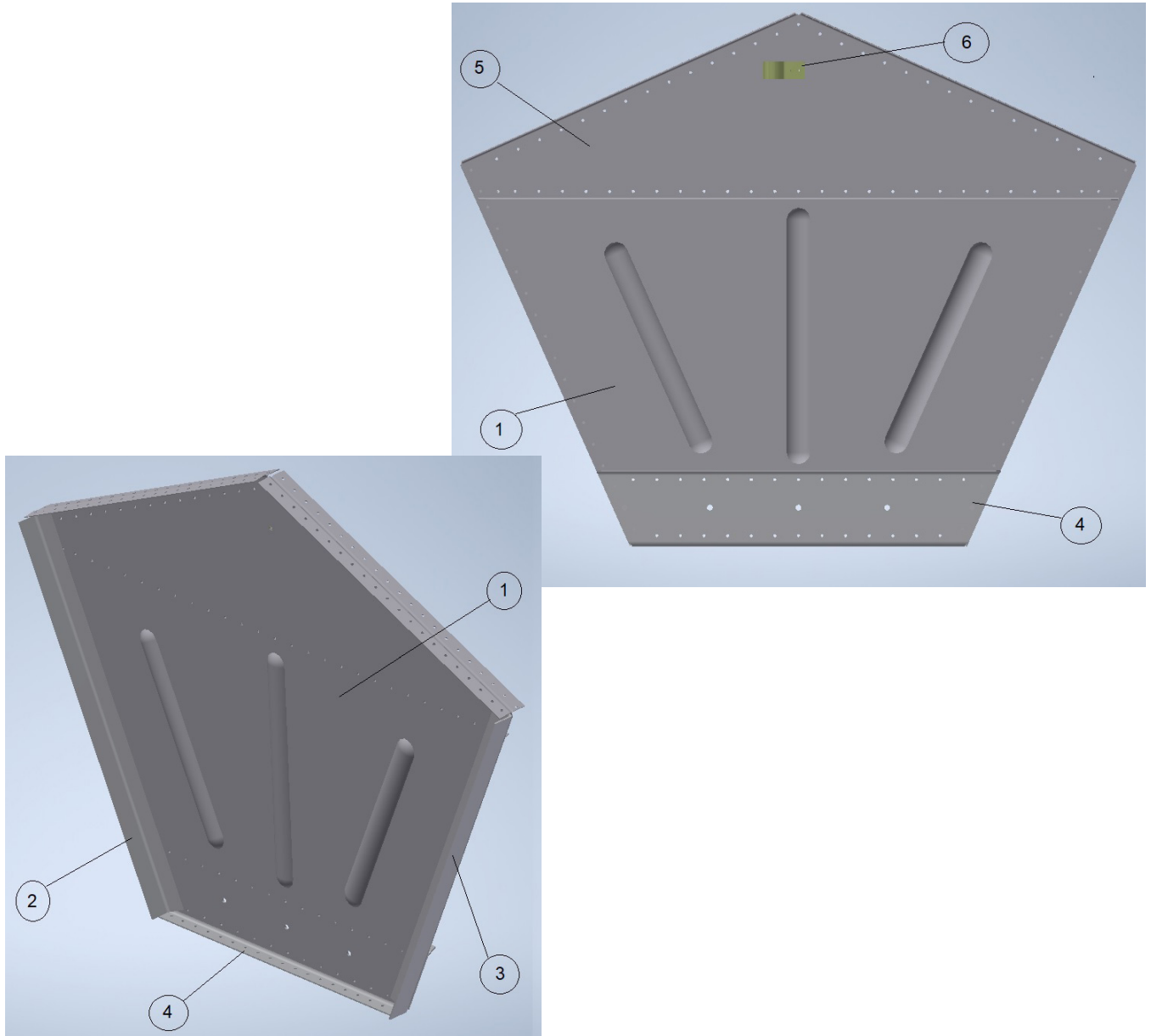

ITEM	QTY	PART NO.	PART DESCRIPTION
-	1	21A01000-253	ASSY BULKHEAD #5
1	1	21A01158-178	BULKHEAD - MAIN
2	1	21A01326-007	ANGLE - SIDE L.
3	1	21A01326-008	ANGLE - SIDE R.
4	1	21A01163-066	PANEL - SPR. BAR
5	1	21A01158-177	SUPPORT - BULKHEAD LOWER
6	1	3A01158-003	CLAMP, PUMP OUT TUBE

BULKHEAD #6

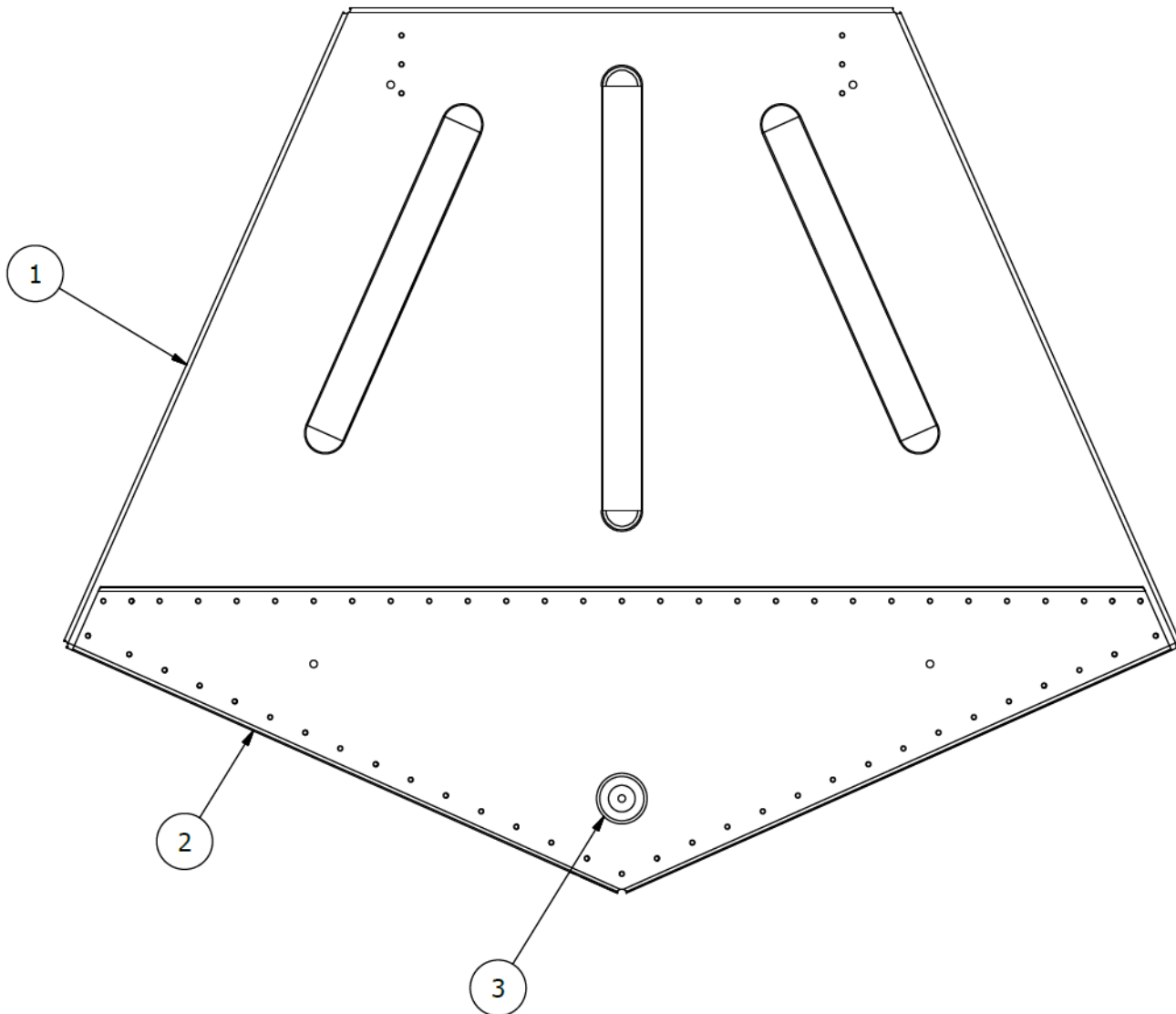

ITEM	QTY	PART NO.	PART DESCRIPTION
-	1	21A01000-252	ASSEMBLY, BULKHEAD #6
1	1	21A01158-189	BULKHEAD #6
2	1	21A01158-177	SUPPORT, BULKHEAD #6
3	1	MS35489-19	GROMMET, RUBBER

BULKHEAD #7 LEFT FLOAT

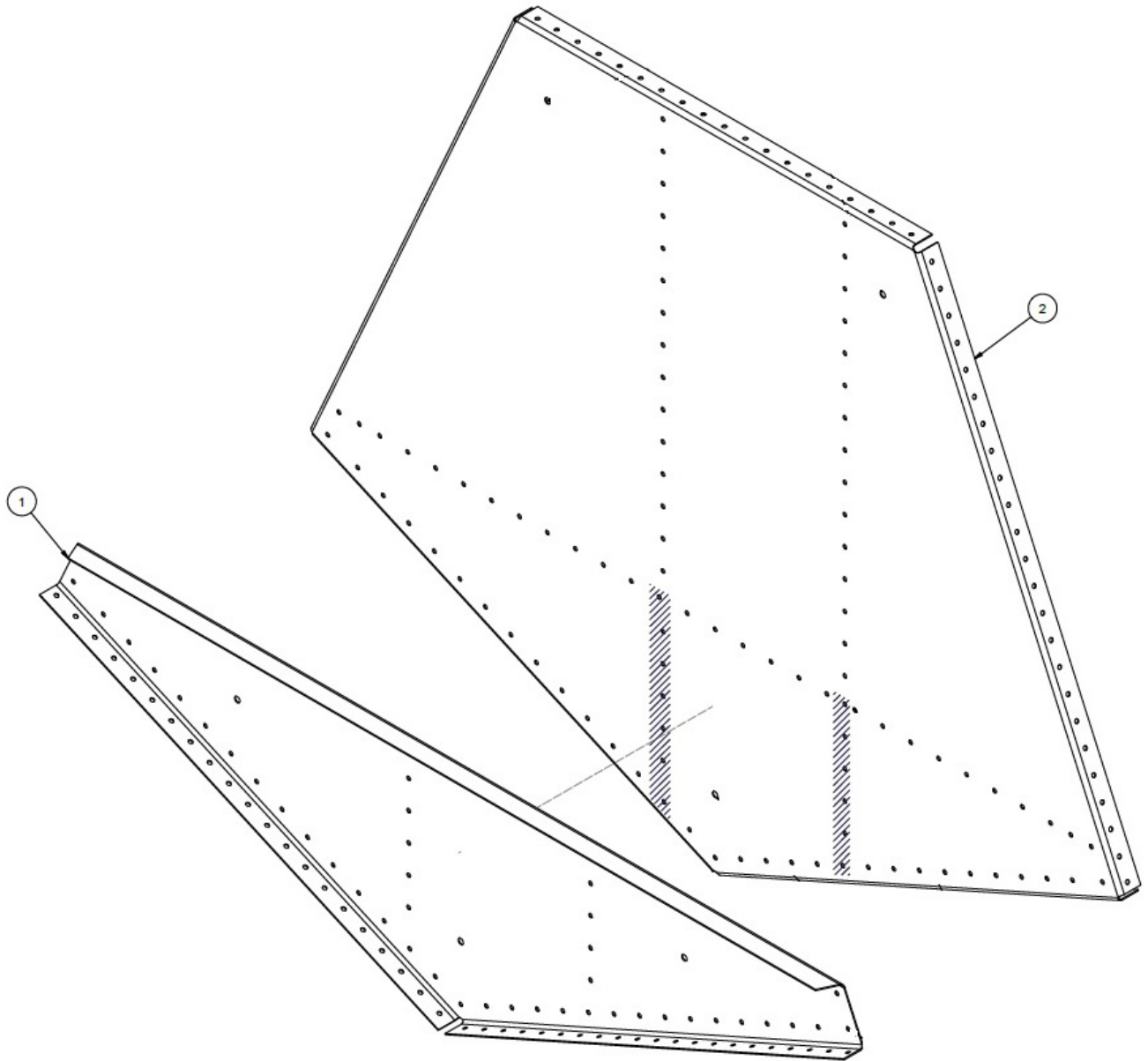

ITEM	QTY	PART NO.	PART DESCRIPTION
-	1	21A01000-267	ASSEMBLY, BULKHEAD #7, LH
1	1	21A01158-187	SUPPORT, BLKHD 7, RH, 2100
2	1	21A01158-181	BULKHEAD #7 - LH

BULKHEAD #7 RIGHT FLOAT

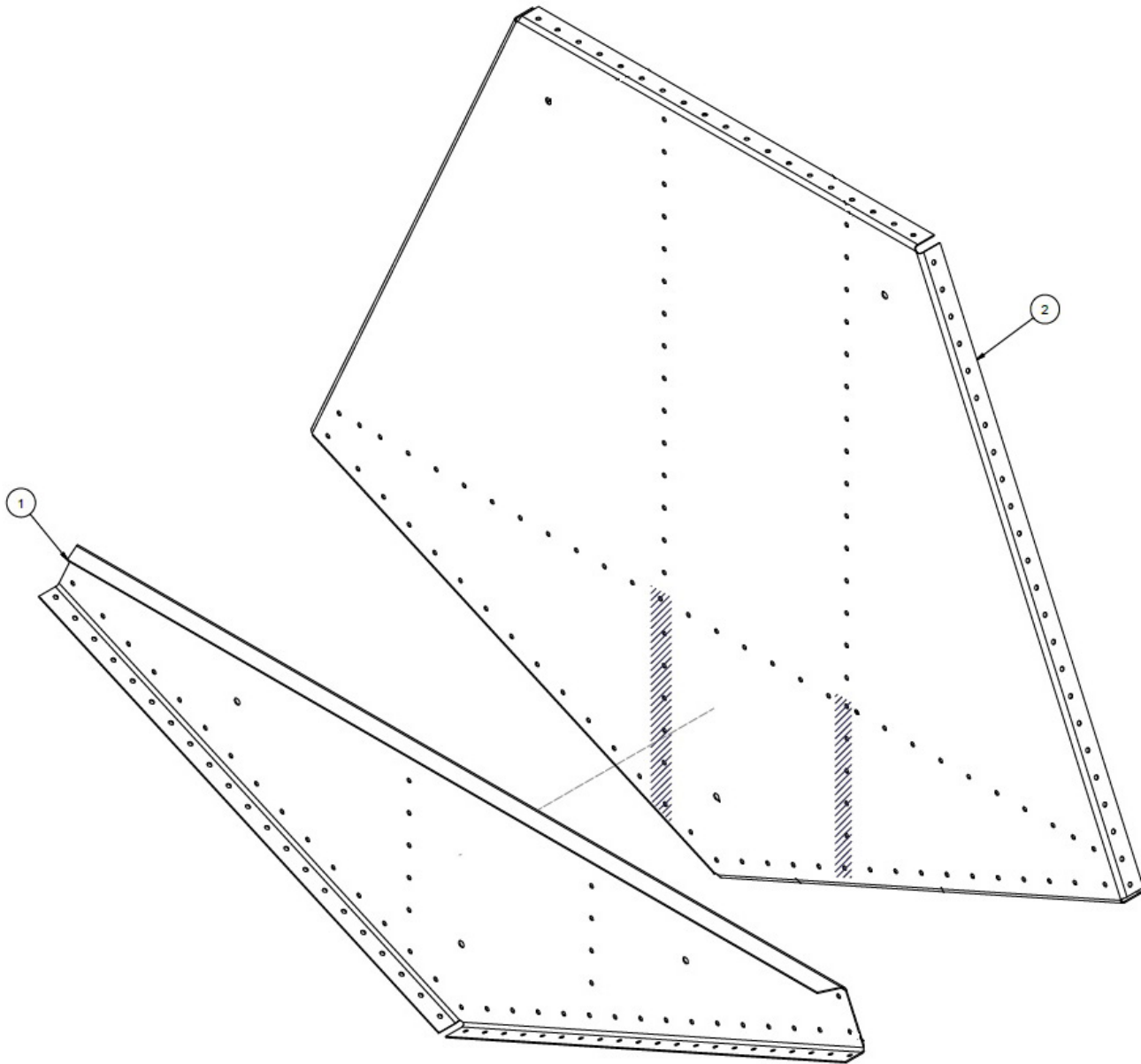

ITEM	QTY	PART NO.	PART DESCRIPTION
-	1	21A01000-266	ASSEMBLY, BULKHEAD #7, RH
1	1	21A01158-188	SUPPORT, BLKHD 7, LH, 2100
2	1	21A01158-182	BULKHEAD #7 - RH

BULKHEAD #8 LEFT FLOAT

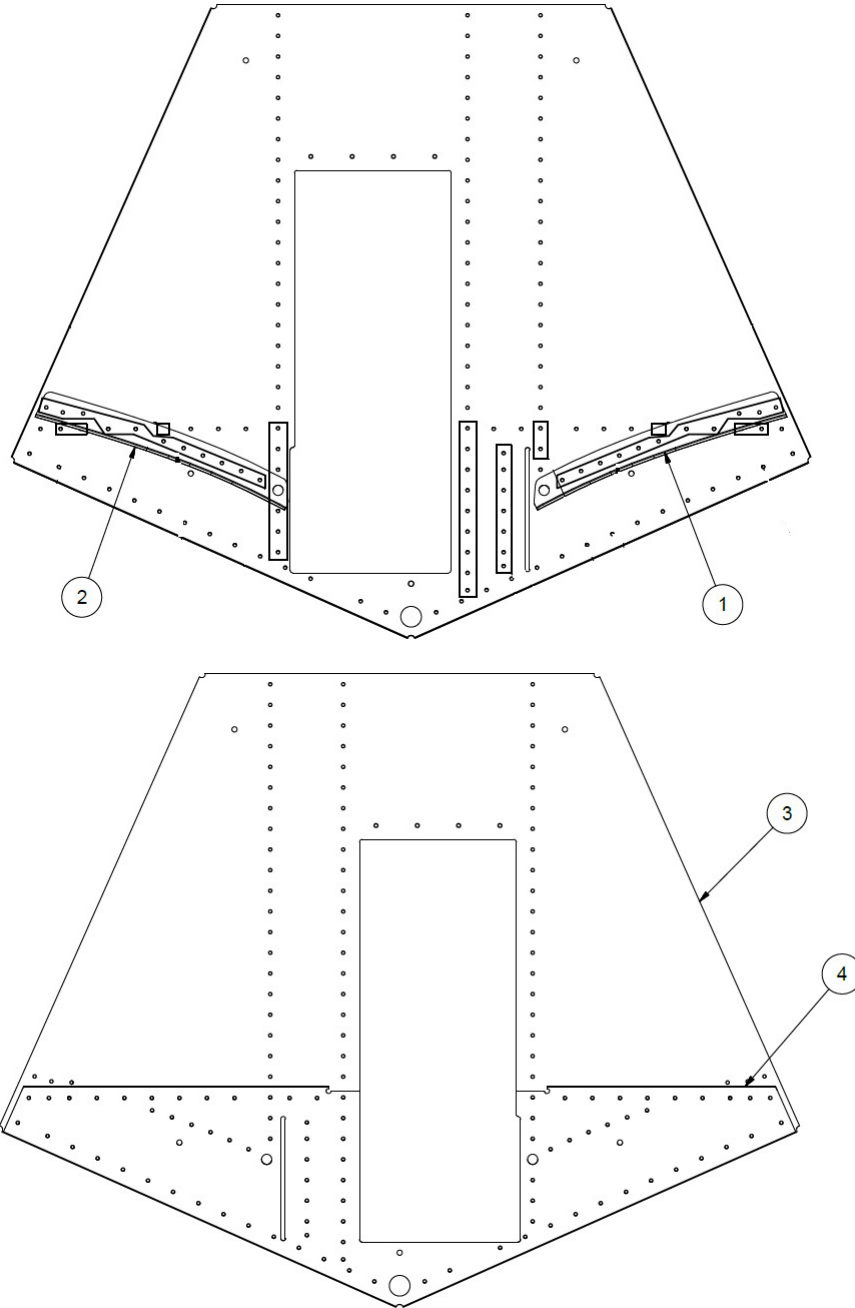

ITEM	QTY	PART NO.	PART DESCRIPTION
-	1	21A01000-263	ASSY, BULKHEAD #8, LH
1	1	21A01158-179	ANGLE - AFTERBODY ATTACH - RH
2	1	21A01158-180	ANGLE - AFTERBODY ATTACH - LH
3	1	21A01158-191	BULKHEAD #8 - LH - FORMED
4	1	21A01158-193	SUPPORT - LH - BULKHEAD #8

BULKHEAD #8 RIGHT FLOAT

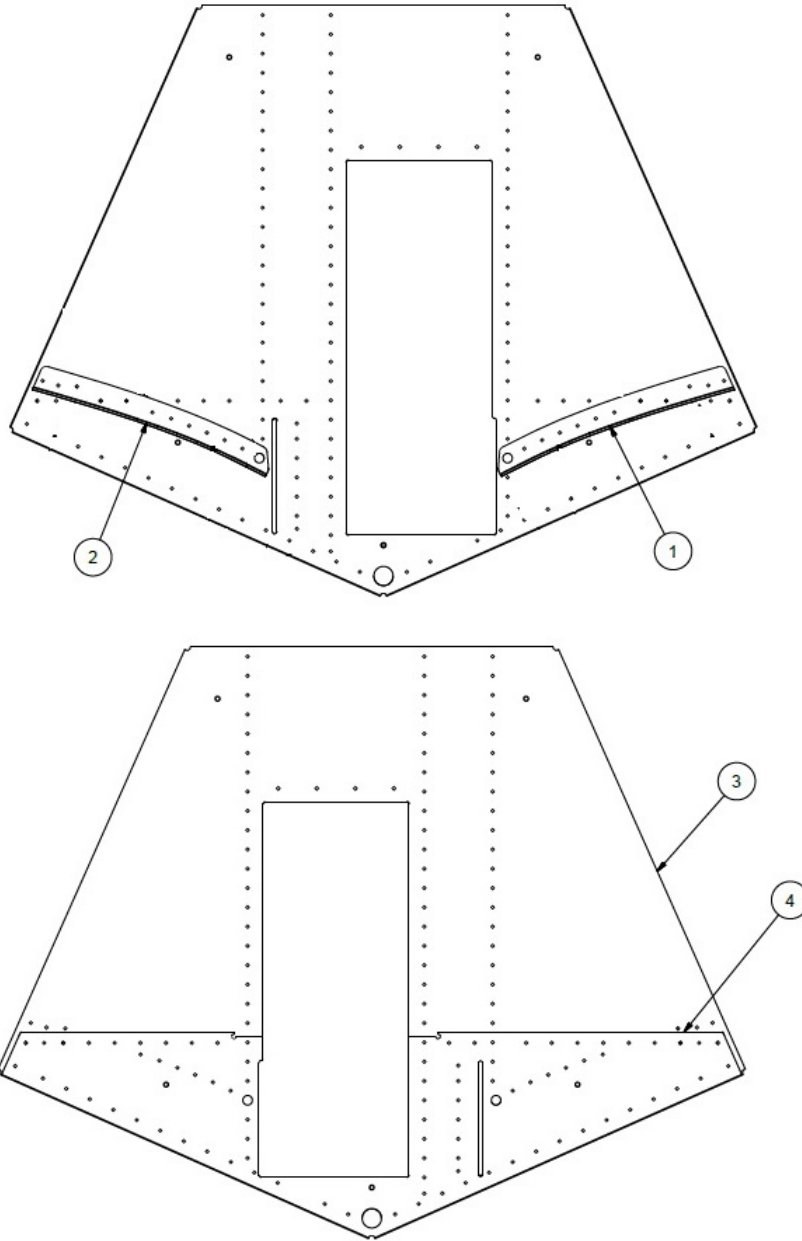

ITEM	QTY	PART NO.	PART DESCRIPTION
-	1	21A01000-264	ASSY, BULKHEAD #8, RH
1	1	21A01158-179	ANGLE - AFTERBODY ATTACH - RH
2	1	21A01158-180	ANGLE - AFTERBODY ATTACH - LH
3	1	21A01158-190	BULKHEAD #8 - RH - FORMED
4	1	21A01158-192	SUPPORT - RH - BULKHEAD #8

BULKHEAD #10

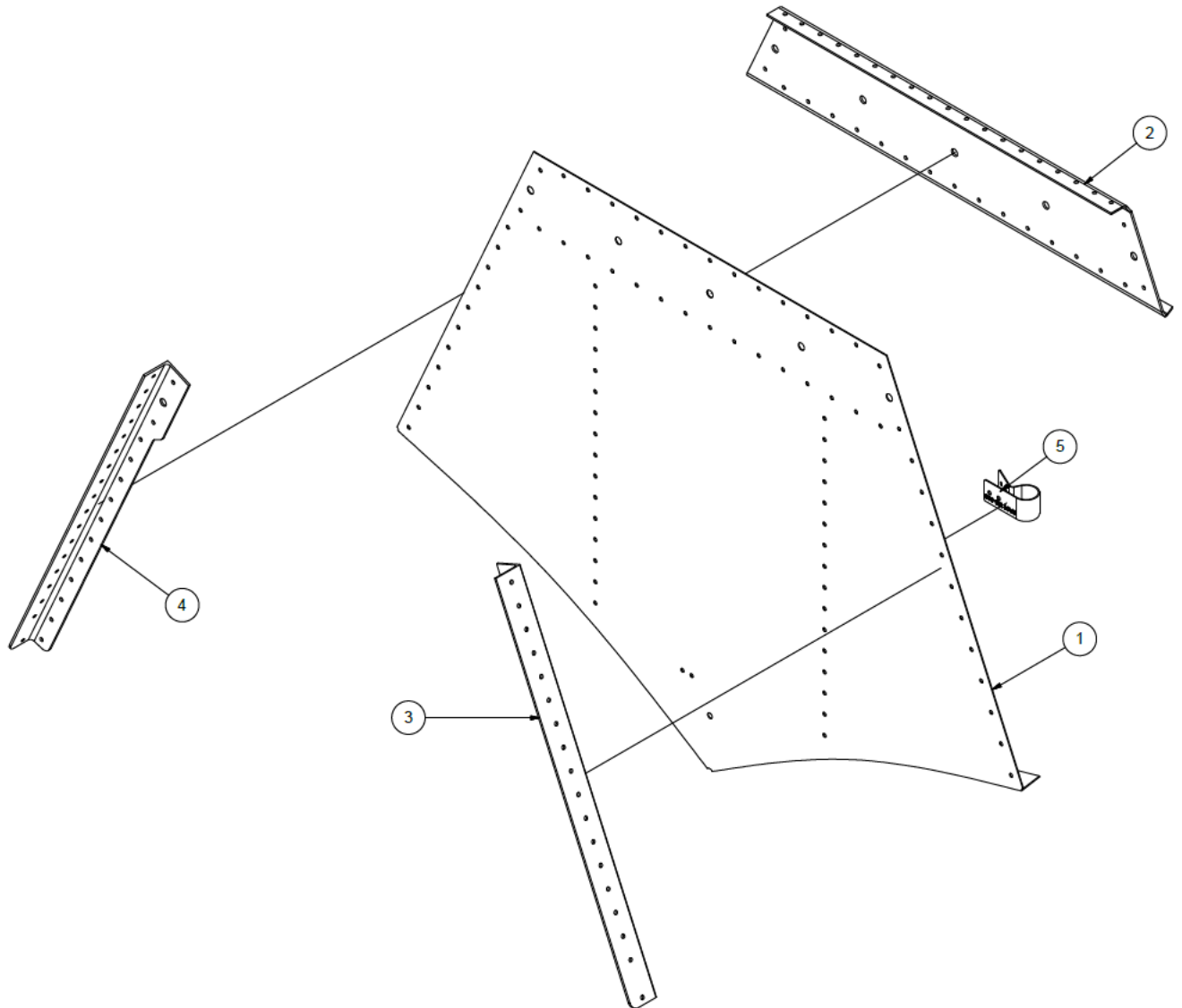

ITEM	QTY	PART NO.	PART DESCRIPTION
-	1	21A01000-262	ASSY, BLKHD 10
1	1	21A01158-169	BULKHEAD #10 - FORMED
2	1	21A01163-066	SPREADER BAR PANEL
3	1	21A01326-011	ANGLE, SIDE BAR, BULKHEAD #10, LF
4	1	21A01326-012	ANGLE, SIDE BAR, BULKHEAD #10, RT
5	1	3A01158-003	CLAMP, PUMP OUT TUBE

BULKHEAD #11

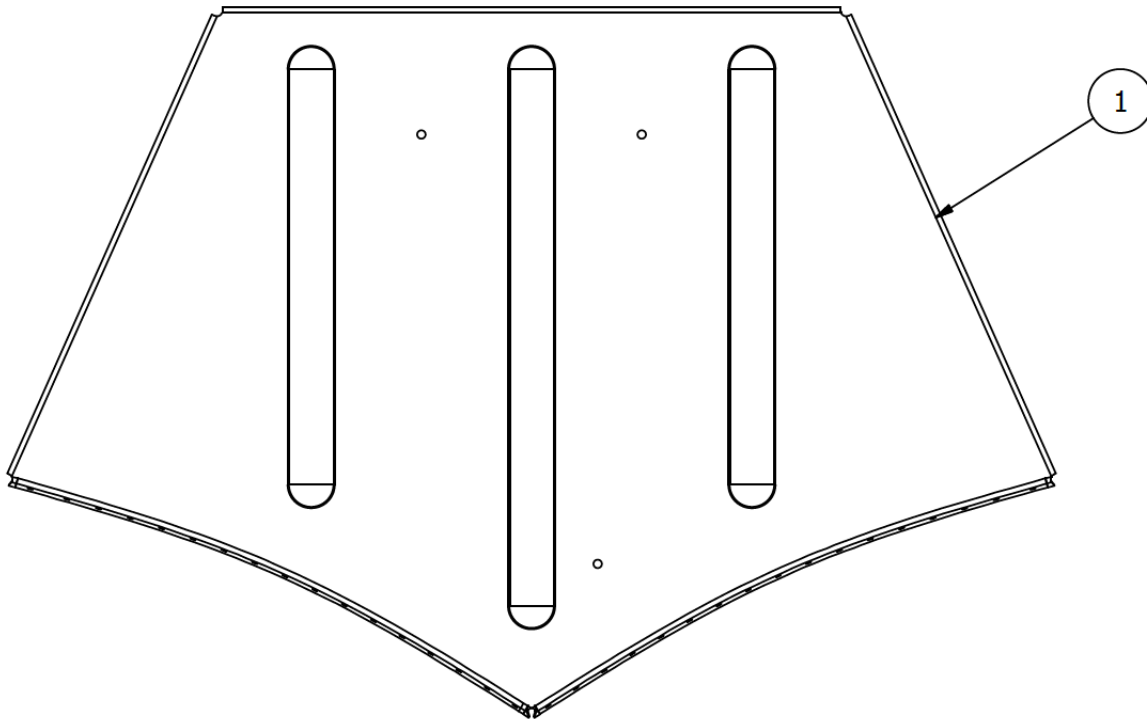

ITEM	QTY	PART NO.	PART DESCRIPTION
-	1	21A01000-395	BULKHEAD STN. #11 ASSY
1	1	21A01158-168	BULKHEAD #11 - FORMED

BULKHEAD #12

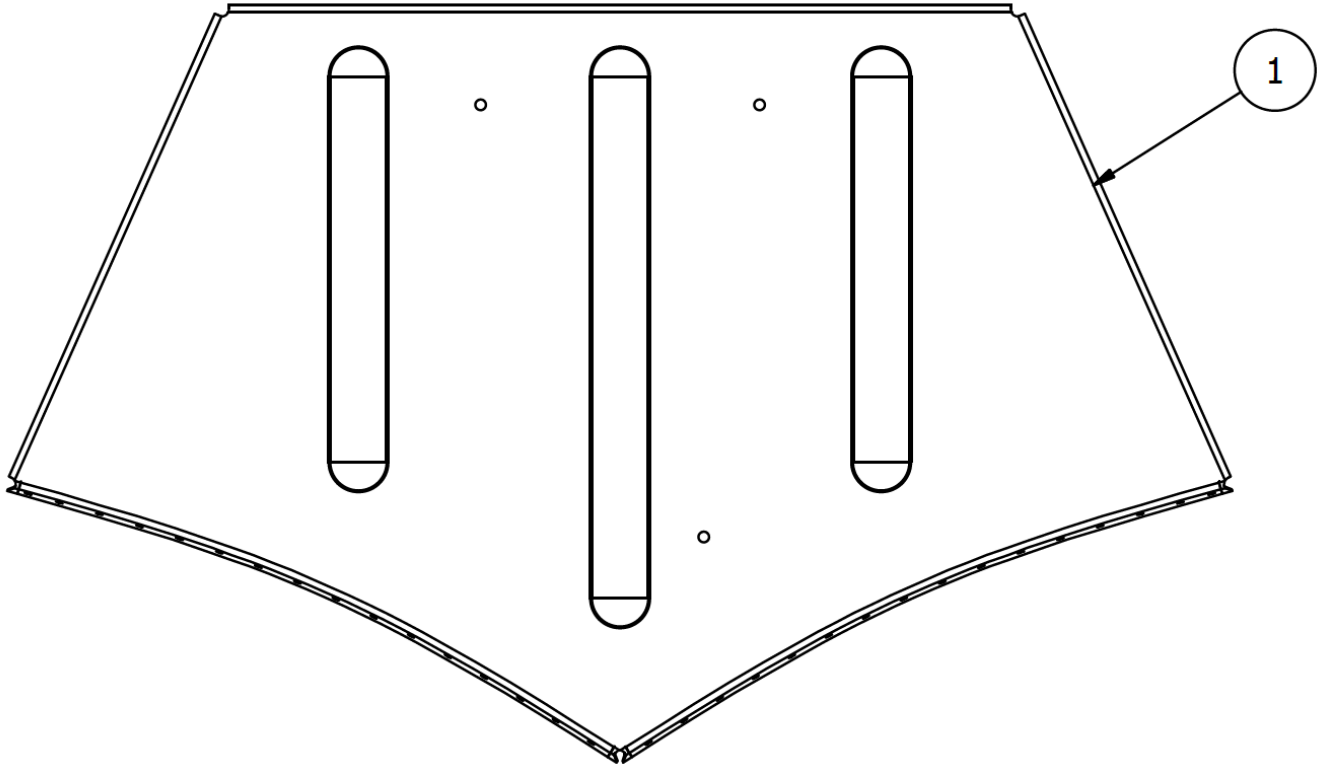

ITEM	QTY	PART NO.	PART DESCRIPTION
-	1	21A01000-396	ASSY, BULKHEAD #12
1	1	21A01158-167	BULKHEAD #12 - FORMED

BULKHEAD #13

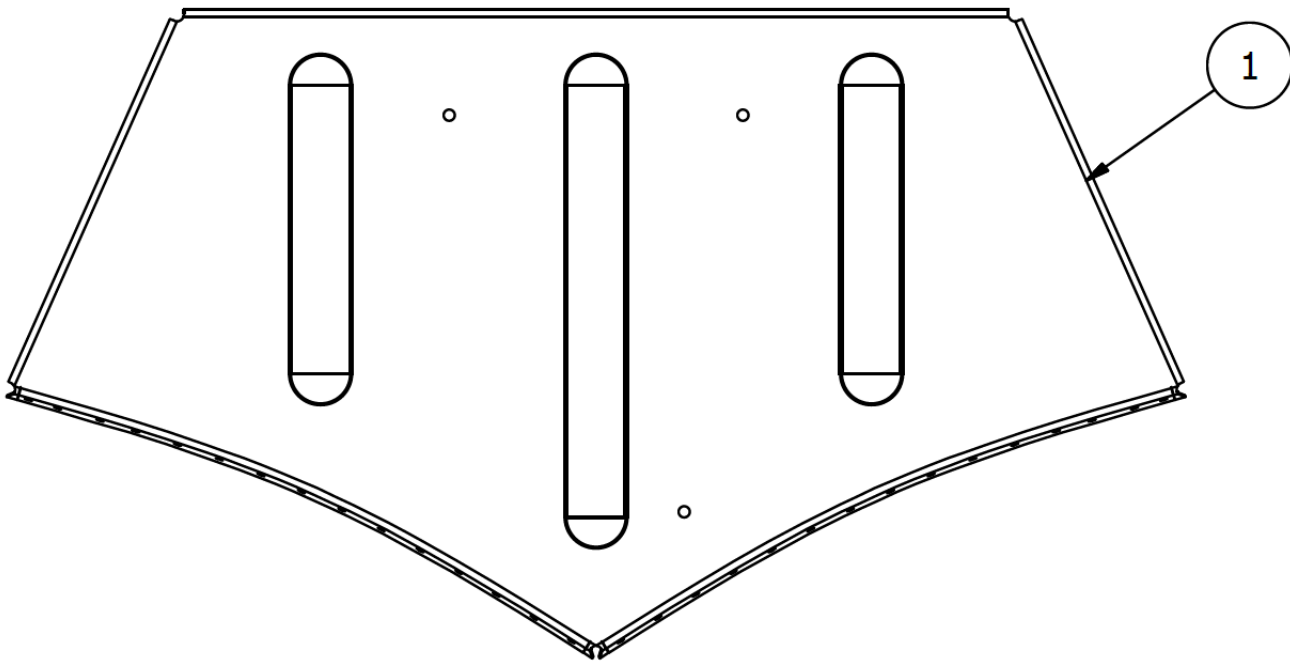

ITEM	QTY	PART NO.	PART DESCRIPTION
-	1	21A01000-397	ASSEMBLY, BULKHEAD #13
1	1	21A01158-166	BULKHEAD #13 - FORMED

BULKHEAD #14

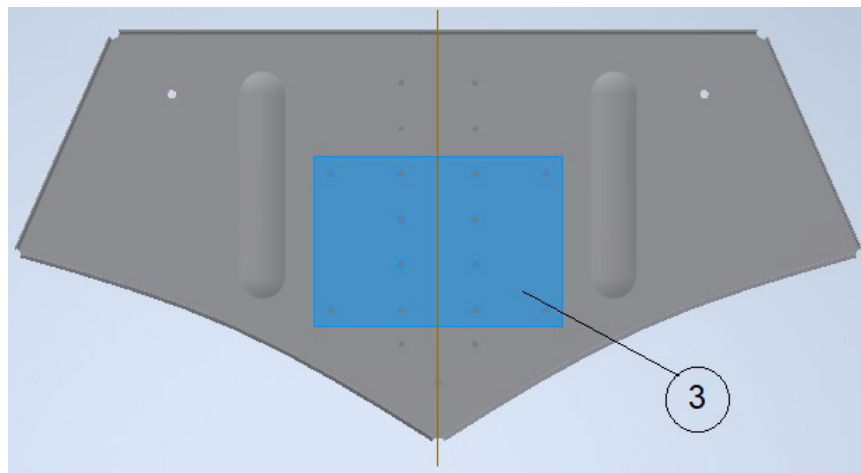
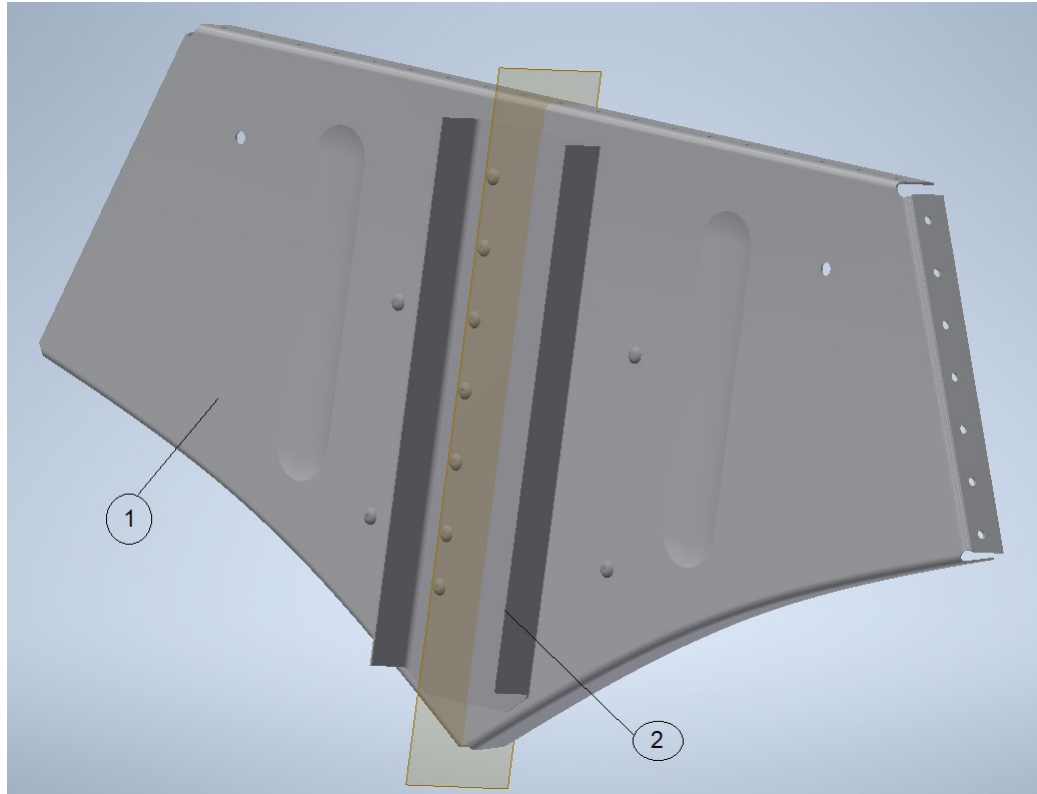

ITEM	QTY	PART NO.	PART DESCRIPTION
-	1	21A01000-250	BULKHEAD STN. #14 ASSY.
1	1	21A01158-164	BULKHEAD STN. #14 FORMED
2	1	21A01158-165	CHANNEL-BULKHEAD #14
3	1	21A08156-130	PLATE-WATER RUDDER STOP

THIS PAGE INTENTIONALLY LEFT BLANK

SECTION 2 WHEEL WELL ASSEMBLY

CONTENTS

WHEEL WELL ASSEMBLY - AMPHIBIAN.....	32
--------------------------------------	----

WHEEL WELL ASSEMBLY - AMPHIBIAN

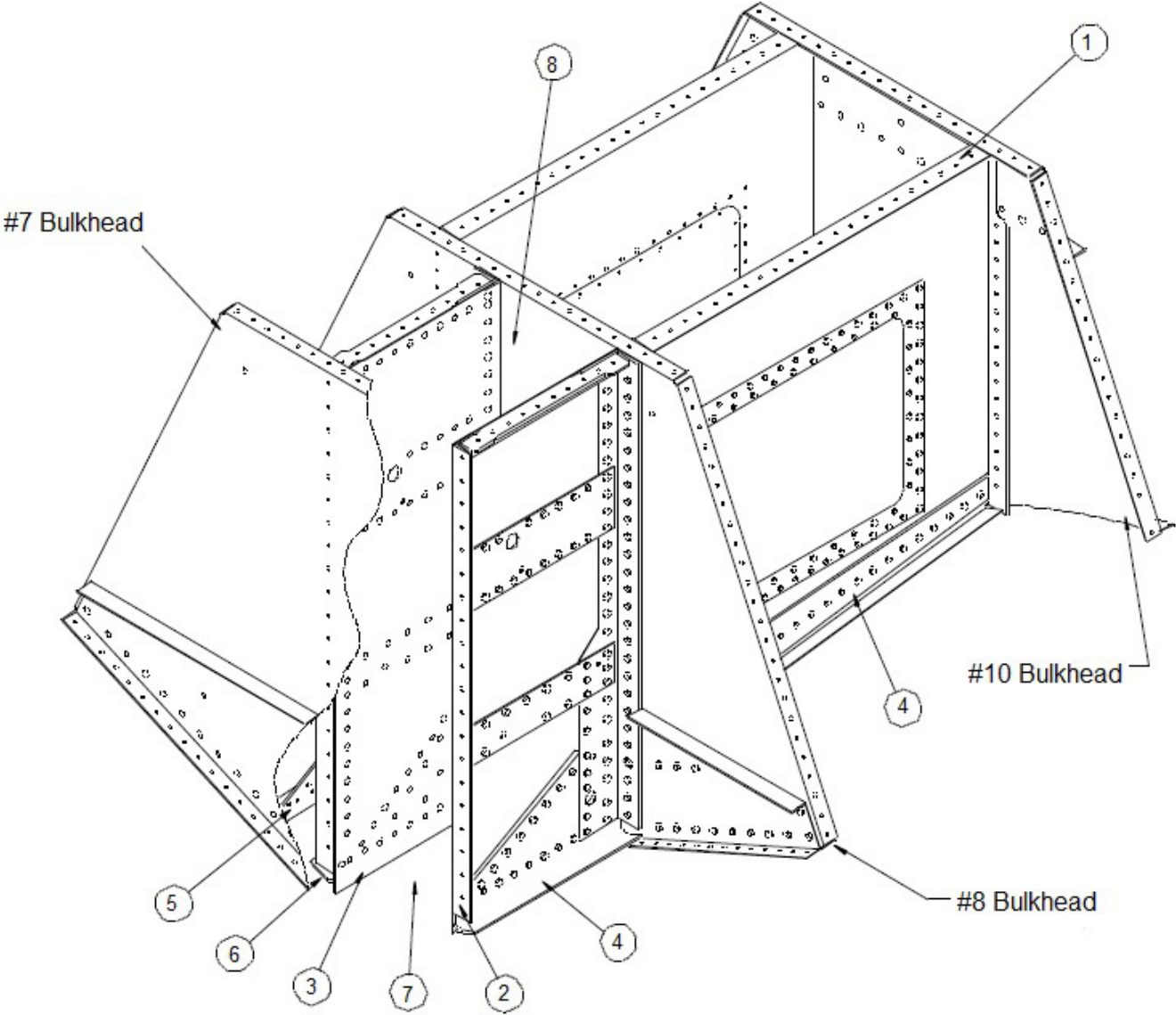

PARTS MANUAL
2100 FLOATS ON CESSNA 170

ITEM	QTY	PART NO.	PART DESCRIPTION
1	1	21A01000-289	ASSY. – WHEELWELL HALF L.
	1	21A01158-185	PANEL – FORMED L.
	1	21A01156-126	RING – COVER REINFORCEMENT
	1	21A01004-101	COVER, WHEEL WELL INSPECTION
	28	AN526-632R6	SCREW TRUSS HEAD, NON STRUCTURAL CAD 1
	1	21A01000-290	ASSY. – WHEELWELL HALF R.
	1	21A01158-186	PANEL – FORMED R.
	1	13A01156-124	RING – COVER REINFORCEMENT
	1	21A01158-163	COVER, INSPECTION, WHEELWELL, LARGE
	28	AN526-632R6	SCREW TRUSS HEAD, NON STRUCTURAL CAD 1
2	1	21A01000-257	ASSY. – WHEELWELL PANEL – OUTBR'D L.
	1	21A01000-256	ASSY. - WHEELWELL PANEL – OUTBR'D R.
3	1	21A01000-255	ASSY. – WHEELWELL PANEL – INBR'D L.
	1	21A01000-254	ASSY. - WHEELWELL PANEL – INBR'D R.
4	1	21A01017-005	CARRY-THRU STRAP OUTBR'D L.
	1	21A01017-004	CARRY-THRU STRAP OUTBR'D R.
5	1	21A01017-003	CARRY-THRU STRAP INBR'D L.
	1	21A01017-002	CARRY-THRU STRAP INBR'D R.
6	1	21A01017-007	CARRY-THRU STRAP INBR'D L.
	1	21A01017-006	CARRY-THRU STRAP INBR'D R.
	1	21A01156-131	ANGLE – ATTACH AFT L.
	1	21A01156-132	ANGLE – ATTACH AFT R.
	1	21A01156-125	SPACER, CARRY THRU STRAP
	2	21A01326-015	ANGLE – ATTACH FWD
7	1	21A01000-398	SAND GUARD ASSY. (NOT SHOWN)
	1	21A01150-136	SAND GUARD (NOT SHOWN)
	4	AN526-1032R8	SCREW, TRUSS HEAD, NON STRUCTURAL, CAD 1, STEEL
	4	MS21078-3	NUT PLATE
8	1	21A01569-001	MUD FLAP (NOT SHOWN)
	1	21A01150-135	REINFORCEMENT

THIS PAGE INTENTIONALLY LEFT BLANK

SECTION 3 SKINS & STIFFENERS

CONTENTS

SKINS & STIFFENERS - AMPHIBIAN.....	36
SKINS & STIFFENERS - SEAPLANE	39
BOTTOM SKIN ASSEMBLIES	42
LEFT BOTTOM SKIN & STIFFENERS.....	43
RIGHT BOTTOM SKIN & STIFFENERS	44

SKINS & STIFFENERS - AMPHIBIAN

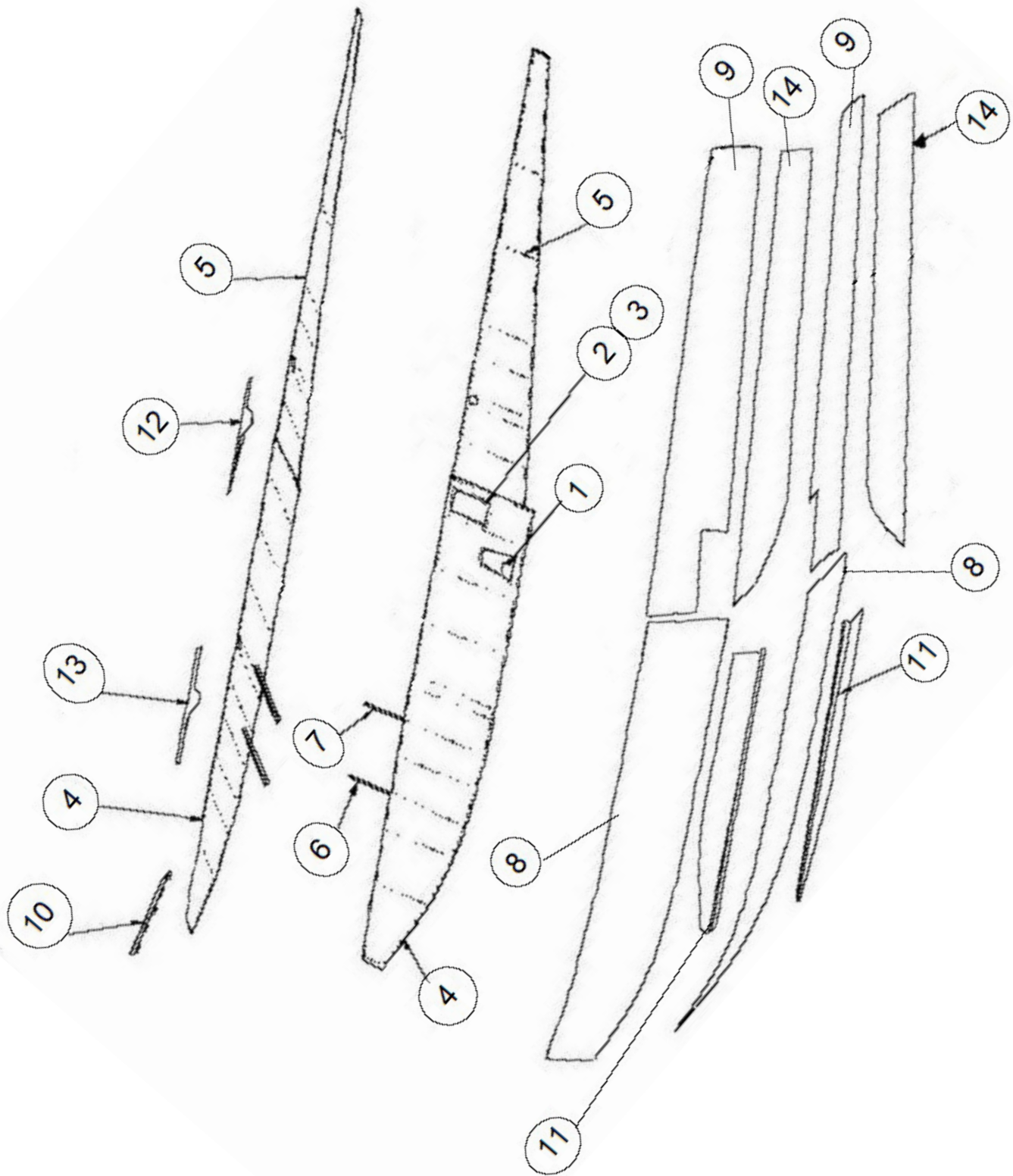

PARTS MANUAL
2100 FLOATS ON CESSNA 170

ITEM	QTY	PART NO.	PART DESCRIPTION
1	1	3A01000-005	STEP – BOARDING
2	2	21A01156-126	REINFORCEMENT – COVER
3	2	21A01000-427	CONVER – INSP. ASSY.
	2	21A01004-101	COVER, WHEEL WELL INSPECTION
	2	21A01567-012	GASKET
	56	AN526-632R6	SCREW TRUSS HEAD, NON STRUCTURAL CAD 1
4	1	21A01004-093	SIDE SKIN – STEP TO BOW L. OUTBR'D
	1	21A01004-094	SIDE SKIN – STEP TO BOW R. OUTBR'D
	1	21A01004-095	SIDE SKIN – STEP TO BOW L. INBR'D
	1	21A01004-096	SIDE SKIN – STEP TO BOW R. INBR'D
	1	3A01158-093	BRACKET (PADDLE)
	1	3A01156-057	STOP (LEFT)
	1	3A01156-058	STOP (RIGHT)
	1	3A01503-001	CLIP, PADDLE
	1	0238-0035	PADDLE 4 FT.
5	1	21A01004-097	SIDE SKIN – STEP TO STERN L. OUTBR'D
	1	21A01004-098	SIDE SKIN – STEP TO STERN R. OUTBR'D
	1	21A01004-099	SIDE SKIN – STEP TO STERN L. INBR'D
	1	21A01004-100	SIDE SKIN – STEP TO STERN R. INBR'D
6	2	21A01340-105	STIFFENER – SIDE SKIN
7	2	21A01340-104	STIFFENER – SIDE SKIN
8	1	1011430	ASSEMBLY, SKIN, BOTTOM, FWD, LEFT, 2100
	1	1011410	SKIN, BOTTOM, LH, FWD 2100
	1	1011412	STIFFENER, BOTTOM SKIN, FWD
	1	1011413	STIFFENER, BOTTOM SKIN, FWD
	1	1011414	STIFFENER, BOTTOM SKIN, FWD
	1	1011416	STIFFENER, BOTTOM SKIN, FWD
	1	1011418	STIFFENER, BOTTOM SKIN, FWD
	3	1011420	STIFFENER, BOTTOM SKIN, FWD
	1	1011431	ASSEMBLY, SKIN, BOTTOM, FWD, RIGHT, 2100
	1	1011411	SKIN, BOTTOM, RH, FWD, 2100
	1	1011412	STIFFENER, BOTTOM SKIN, FWD
	1	1011413	STIFFENER, BOTTOM SKIN, FWD
	1	1011415	STIFFENER, BOTTOM SKIN, FWD
	1	1011417	STIFFENER, BOTTOM SKIN, FWD
	1	1011419	STIFFENER, BOTTOM SKIN, FWD
	3	1011421	STIFFENER, BOTTOM SKIN, FWD
9	1	21A01004-103	BOTTOM SKIN AFTERBODY L.
	1	21A01004-104	BOTTOM SKIN AFTERBODY R.
10	1	21A01000-275	ASSY. SPRAY RAIL R.
	1	21A01000-274	ASSY. SPRAY RAIL L.

ITEM	QTY	PART NO.	PART DESCRIPTION
11	1	21A01150-133	BOOSTER – SISTER KEEL L.
	1	21A01150-132	BOOSTER – SISTER KEEL R.
12	1	21A01162-033	DOUBLER – GUNWALL AFT L.
	1	21A01162-034	DOUBLER – GUNWALL AFT R.
13	1	21A01162-031	DOUBLER – GUNWALL FWD L.
	1	21A01162-032	DOUBLER – GUNWALL FWD R.
14	1	1009422	SCALLOP, FOAM, RIGHT, 2100 S/N 21977 AND LATER
	1	1009424	SCALLOP, FOAM, LEFT, 2100 S/N 21977 AND LATER

SKINS & STIFFENERS - SEAPLANE

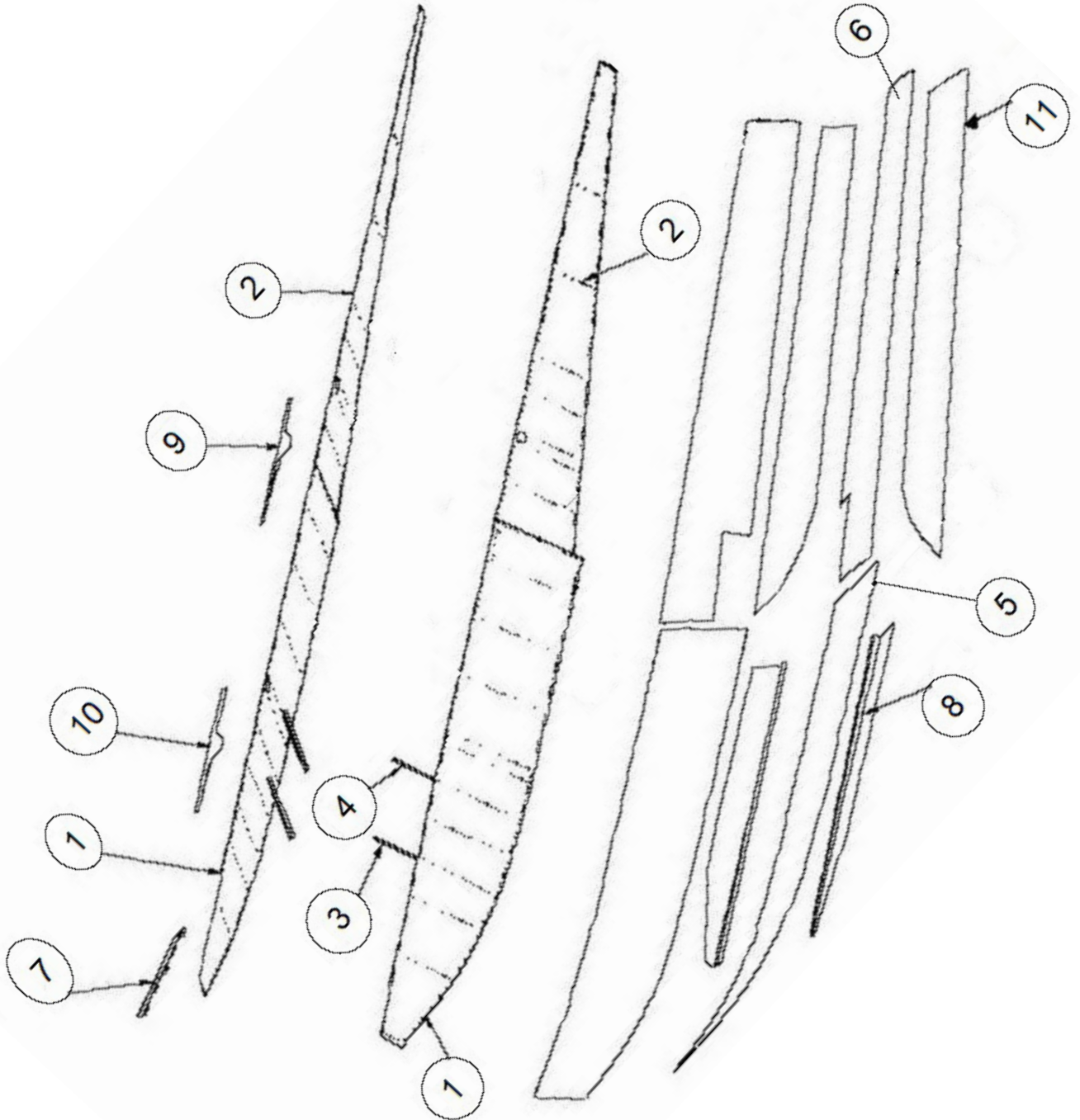

ITEM	QTY	PART NO.	PART DESCRIPTION
1	1	21S01004-123	SIDE SKIN – STEP TO BOW L. OUTBR'D
	1	21S01004-122	SIDE SKIN – STEP TO BOW R. OUTBR'D
	1	21S01004-125	SIDE SKIN – STEP TO BOW L. INBR'D
	1	21S01004-124	SIDE SKIN – STEP TO BOW R. INBR'D
	1	3A01158-093	BRACKET (PADDLE)
	1	3A01156-057	STOP (LEFT)
	1	3A01156-058	STOP (RIGHT)
	1	3A01503-001	CLIP, PADDLE
	1	0238-0035	PADDLE
2	1	21A01004-097	SIDE SKIN – STEP TO STERN L. OUTBR'D
	1	21A01004-098	SIDE SKIN – STEP TO STERN R. OUTBR'D
	1	21A01004-099	SIDE SKIN – STEP TO STERN L. INBR'D
	1	21A01004-100	SIDE SKIN – STEP TO STERN R. INBR'D
3	2	21A01340-105	STIFFENER – SIDE SKIN
4	2	21A01340-104	STIFFENER – SIDE SKIN
5	1	1011430	ASSEMBLY, SKIN, BOTTOM, FWD, LEFT, 2100
	1	1011410	SKIN, BOTTOM, LH, FWD 2100
	1	1011412	STIFFENER, BOTTOM SKIN, FWD
	1	1011413	STIFFENER, BOTTOM SKIN, FWD
	1	1011414	STIFFENER, BOTTOM SKIN, FWD
	1	1011416	STIFFENER, BOTTOM SKIN, FWD
	1	1011418	STIFFENER, BOTTOM SKIN, FWD
	3	1011420	STIFFENER, BOTTOM SKIN, FWD
	1	1011431	ASSEMBLY, SKIN, BOTTOM, FWD, RIGHT, 2100
	1	1011411	SKIN, BOTTOM, RH, FWD, 2100
	1	1011412	STIFFENER, BOTTOM SKIN, FWD
	1	1011413	STIFFENER, BOTTOM SKIN, FWD
	1	1011415	STIFFENER, BOTTOM SKIN, FWD
	1	1011417	STIFFENER, BOTTOM SKIN, FWD
	1	1011419	STIFFENER, BOTTOM SKIN, FWD
	3	1011421	STIFFENER, BOTTOM SKIN, FWD
6	1	21S01004-131	BOTTOM SKIN AFTERBODY L.
	1	21S01004-130	BOTTOM SKIN AFTERBODY R.
7	1	21A01000-275	ASSY. SPRAY RAIL R.
	1	21A01000-274	ASSY. SPRAY RAIL L.
8	1	21A01150-133	BOOSTER – SISTER KEEL L.
	1	21A01150-132	BOOSTER – SISTER KEEL R.
9	1	21A01162-033	DOUBLER – GUNWALL AFT L.
	1	21A01162-034	DOUBLER – GUNWALL AFT R.
10	1	21A01162-031	DOUBLER – GUNWALL FWD L.
	1	21A01162-032	DOUBLER – GUNWALL FWD R.

PARTS MANUAL
2100 FLOATS ON CESSNA 170

ITEM	QTY	PART NO.	PART DESCRIPTION
11	1	1009422	SCALLOP, FOAM, RIGHT, 2100 S/N 21977 AND LATER
	1	1009424	SCALLOP, FOAM, LEFT, 2100 S/N 21977 AND LATER

BOTTOM SKIN ASSEMBLIES

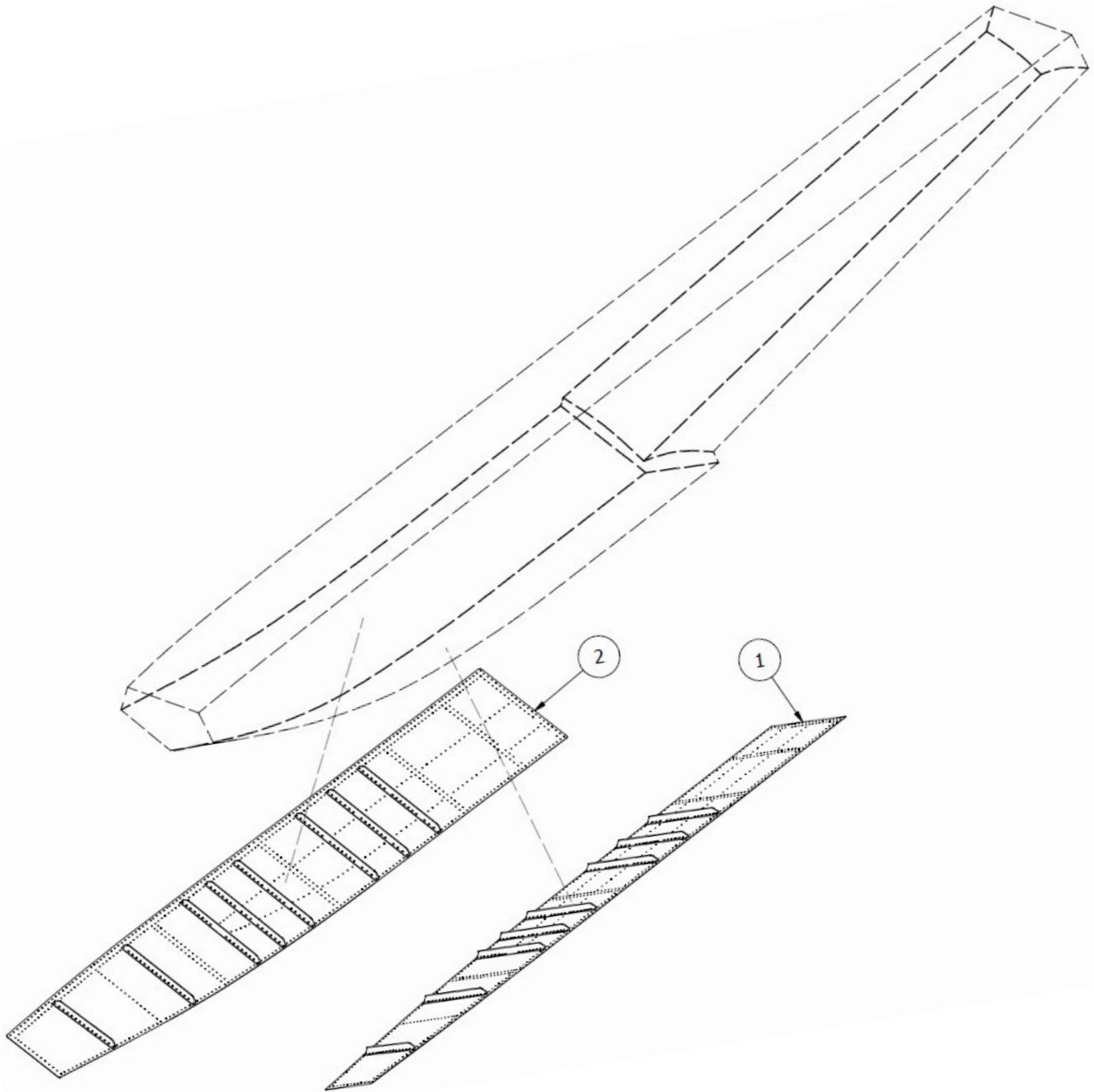

ITEM	QTY	PART NO.	PART DESCRIPTION
1	1	1011430	ASSEMBLY, SKIN, BOTTOM, FWD, LEFT, 2100
2	1	1011431	ASSEMBLY, SKIN, BOTTOM, FWD, RIGHT, 2100

LEFT BOTTOM SKIN & STIFFENERS

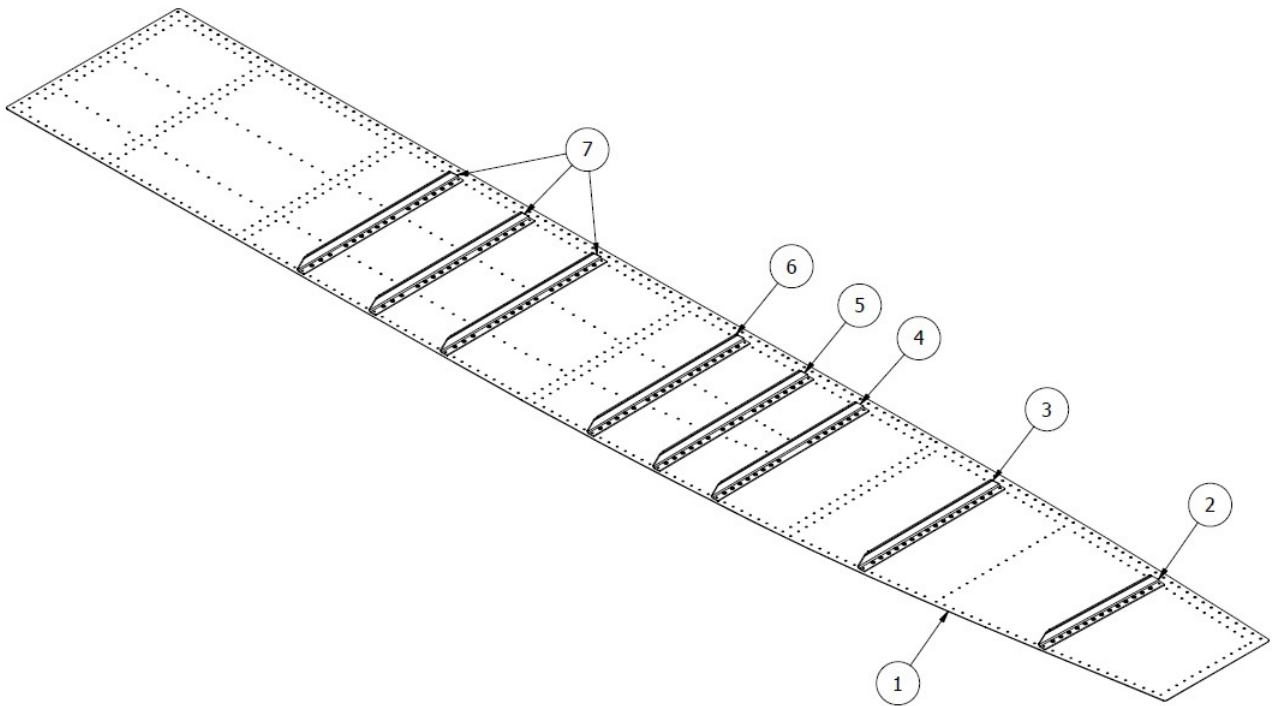

ITEM	QTY	PART NO.	PART DESCRIPTION
1	1	1011410	SKIN, BOTTOM, LH, FWD 2100
2	1	1011412	STIFFENER, BOTTOM SKIN, FWD
3	1	1011413	STIFFENER, BOTTOM SKIN, FWD
4	1	1011414	STIFFENER, BOTTOM SKIN, FWD
5	1	1011416	STIFFENER, BOTTOM SKIN, FWD
6	1	1011418	STIFFENER, BOTTOM SKIN, FWD
7	3	1011420	STIFFENER, BOTTOM SKIN, FWD

RIGHT BOTTOM SKIN & STIFFENERS

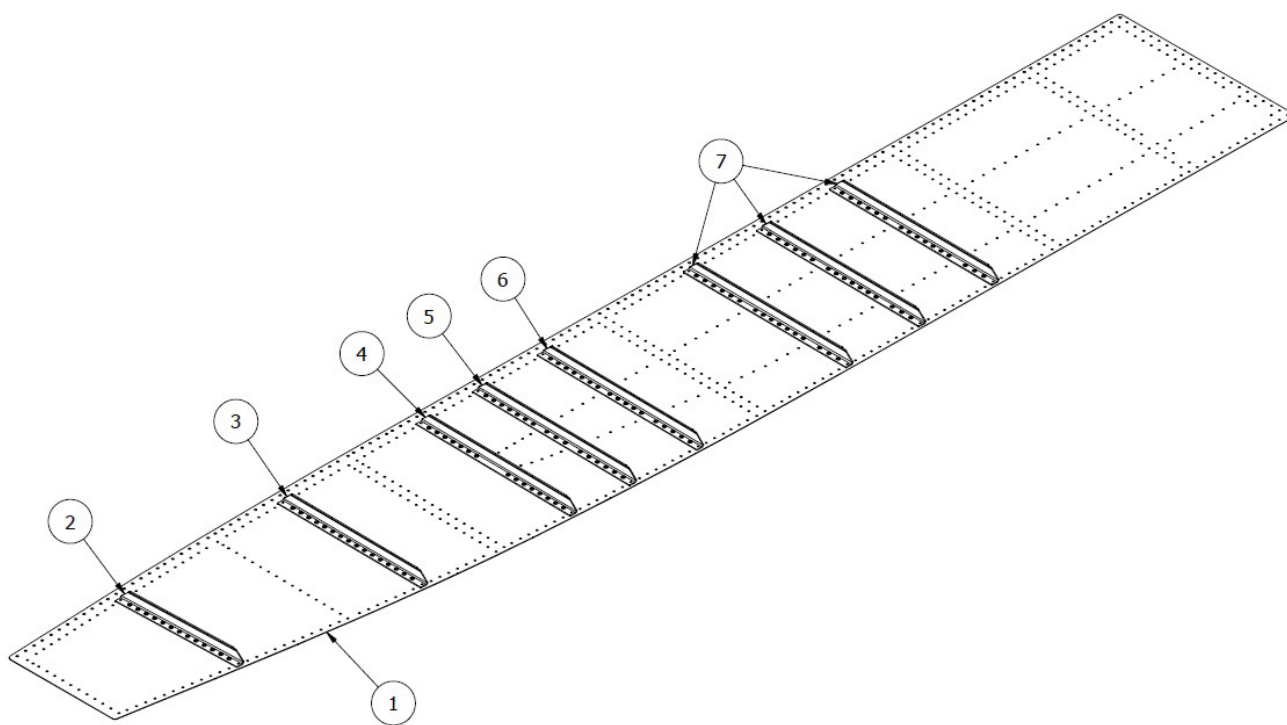

ITEM	QTY	PART NO.	PART DESCRIPTION
1	1	1011411	SKIN, BOTTOM, RH, FWD, 2100
2	1	1011412	STIFFENER, BOTTOM SKIN, FWD
3	1	1011413	STIFFENER, BOTTOM SKIN, FWD
4	1	1011415	STIFFENER, BOTTOM SKIN, FWD
5	1	1011417	STIFFENER, BOTTOM SKIN, FWD
6	1	1011419	STIFFENER, BOTTOM SKIN, FWD
7	3	1011421	STIFFENER, BOTTOM SKIN, FWD

SECTION 4 TOP DECK ASSEMBLY

CONTENTS

TOP DECK - AMPHIBIAN	46
TOP DECK - SEAPLANE.....	49

TOP DECK - AMPHIBIAN

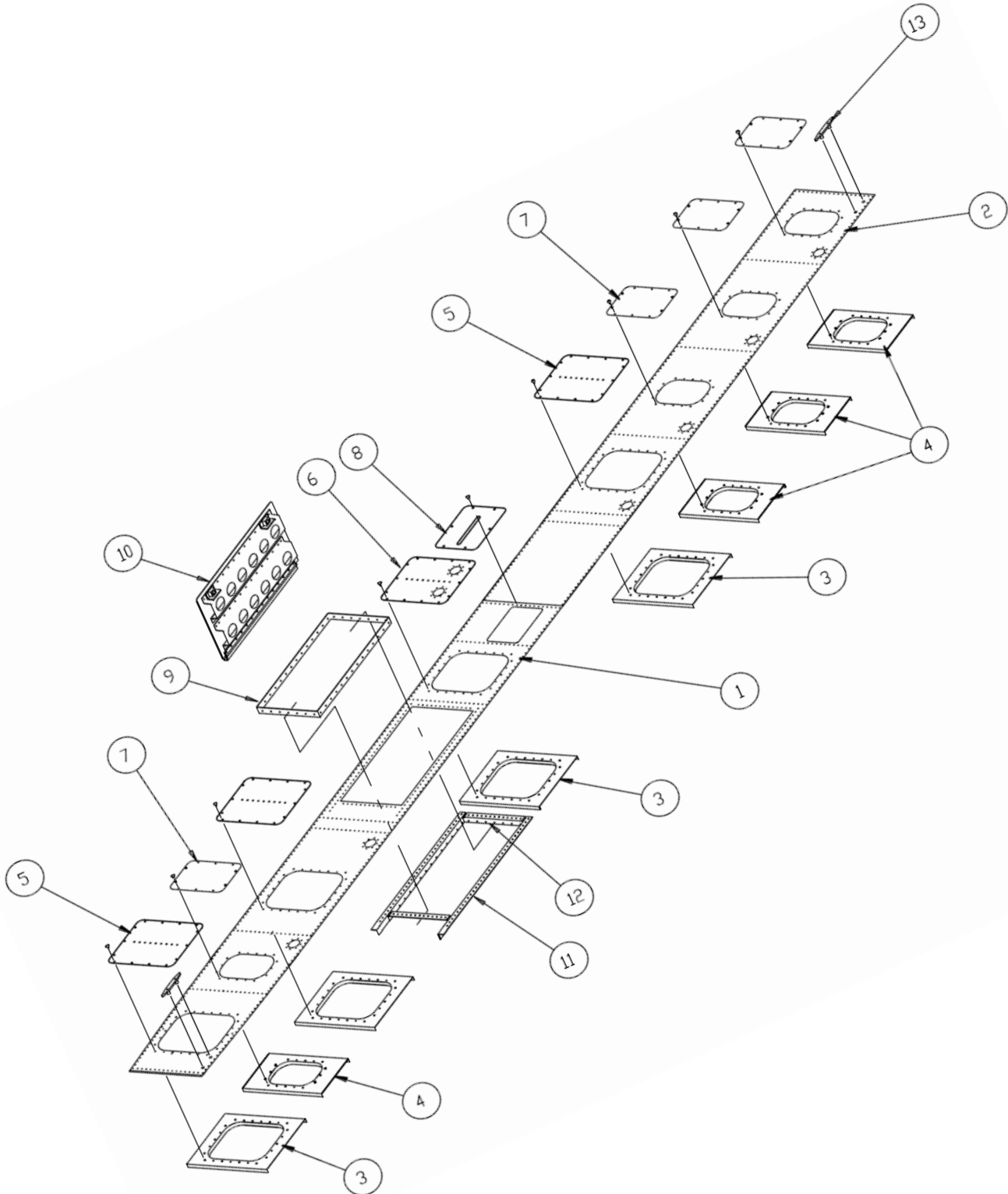

PARTS MANUAL
2100 FLOATS ON CESSNA 170

ITEM	QTY	PART NO.	PART DESCRIPTION
1	1	21A01004-091	SKIN – FWD SECTION L.
	1	21A01004-092	SKIN – FWD SECTION R.
2	1	21A01004-089	SKIN – AFT SECTION L.
	1	21A01004-090	SKIN – AFT SECTION R.
3	4	21A01002-130	SUPPORT – INSP. COVER - LARGE
	A/R	1002481	TINNERMAN WITH TAPE
4	4	21A01002-131	SUPPORT – INSP. COVER – SMALL
	A/R	1002481	TINNERMAN WITH TAPE
5	3	21A01000-258	INSP. COVER ASSY– LARGE – W/ ANGLE & GASKET
	A/R	SS TATP 8 X 5/8	SCREW – ATTACH
	3	1001437	SEAL – GASKET ONLY (FORMED COVER)
	3	21A01567-001	SEAL – GASKET ONLY (FLAT COVER)
6	1	21A01000-273	INSP. COVER ASSY, LARGE, W/ ANGLE (2 CUPS) & GASKET
	A/R	SS TATP 8 X 5/8	SCREW – ATTACH
	3	1001437	SEAL – GASKET ONLY (FORMED COVER)
	3	21A01567-001	SEAL – GASKET ONLY (FLAT COVER)
7	4	21A01000-284	INSP. COVER ASSY - SMALL
	A/R	SS TATP 8 X 5/8	SCREW – ATTACH
	3	1001437	SEAL – GASKET ONLY (FORMED COVER)
	3	21A01567-002	SEAL – GASKET ONLY (FLAT COVER)
8	1	21A01002-137	COVER – GEAR INDICATOR L.
	1	21A01002-138	COVER – GEAR INDICATOR R.
	1	10A3-6338-1	PLACARD – DOWN - LAND
	1	10A3-6338-2	PLACARD – UP - WATER
	4	2600-3	SCREW – CAM - LOK
	2	1126000-5	SCREW – CAM – LOK
	6	212-12N	RECEPTACLE – CAM – LOK
9	1	21A01150-131	JAMB – BAGGAGE DOOR
	1	1002067	BAGGAGE JAMB, HINGE SIDE
10	1	21A01000-268	ASSY – BAGGAGE DOOR
	1	21A01162-035	COVER - SKIN
	1	21A01740-008	HINGE, BAGGAGE COVER, 1.5
	1	21A01741-004	HINGE, BAGGAGE COVER, 3/4
	2	21A01010-012	STIFFENER - DOOR
	2	21A01004-106	STIFFENER ENDS
	2	3A01206-001	RETAINER - LOCK
	2	3A01273-004	LOCK PIN
	2	3A01702-001	CATCH – LATCH
	2	3A01525-003	LOCK SPRING
	2	1002663	RING – OPENING
	1	1001438	SEAL – GASKET (NOT SHOWN)

ITEM	QTY	PART NO.	PART DESCRIPTION
	1	1002186	HINGE PIN
	12	01692-0410	RIVET POP
	2	10/32 X 1/2 SS	BOLT
11	1	21A01326-003	TOP RAIL – BAGGAGE OPENING L.
	1	21A01326-002	TOP RAIL – BAGGAGE OPENING R.
12	2	21A01326-004	JAMB – BAGGAGE DOOR
13	2	21A01203-001	CLEAT – TIE DOWN
	4	21A01280-004	BUSHING
	4	AN525-10R24	SCREW, 10-32 THREAD, 1-3/32" GRIP, 1-1/2" LENGTH
	4	MS21044N3	NUT, LOCKING, REGULAR HEIGHT, 10-32 UNF
	4	NAS1149D0363J	WASHER, 0.203 ID, 0.063 THK, ALUMINUM

TOP DECK - SEAPLANE

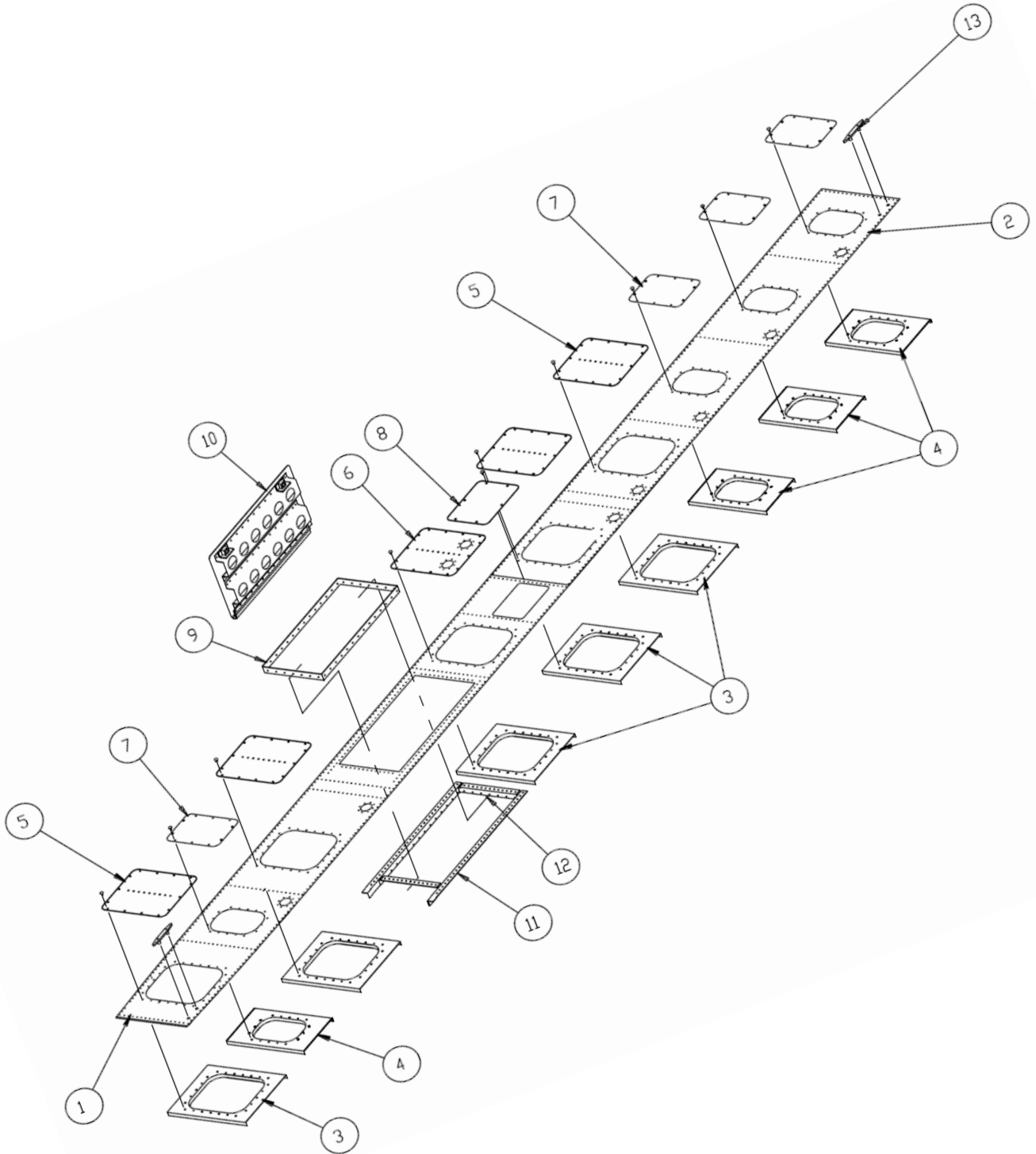

ITEM	QTY	PART NO.	PART DESCRIPTION
1	1	21S01004-135	SKIN – FWD SECTION L.
	1	21S01004-134	SKIN – FWD SECTION R.
2	1	21S01004-137	SKIN – AFT SECTION L.
	1	21S01004-136	SKIN – AFT SECTION R.
3	4	21A01002-130	SUPPORT – INSP. COVER - LARGE
	A/R	1002481	TINNERMAN WITH TAPE
4	5	21A01002-131	SUPPORT – INSP. COVER – SMALL
	A/R	1002481	TINNERMAN WITH TAPE
5	4	21A01000-258	INSP. COVER ASSY – LARGE – W/ ANGLE & GASKET
	A/R	SS TATP 8 X 5/8	SCREW – ATTACH
	3	1001437	SEAL – GASKET ONLY (FORMED COVER)
	3	21A01567-001	SEAL – GASKET ONLY (FLAT COVER)
6	1	2A01000-273	INSP. COVER – LARGE – ANGLE (2 CUPS) & GASKET
	A/R	SS TATP 8 X 5/8	SCREW – ATTACH
	3	1001437	SEAL – GASKET ONLY (FORMED COVER)
	3	21A01567-001	SEAL – GASKET ONLY (FLAT COVER)
7	4	21A01000-284	INSP. COVER ASSY- SMALL & GASKET
	A/R	SS TATP 8 X 5/8	SCREW – ATTACH
	4	1001728	SEAL – GASKET ONLY (FORMED COVER)
	3	21A01567-002	SEAL – GASKET ONLY (FLAT COVER)
8	1	21S01000-399	COVER ASSY & GASKET
	1	1002110	SEAL – GASKET ONLY
	A/R	SS TATP 8 X 5/8	SCREW – ATTACH
	A/R	9A3-671	NUT – TINNERMAN
	2	30S01326-035	STIFFENER – ANGLE
9	1	21A01150-131	JAMB – BAGGAGE DOOR
	1	101438	SEAL – GASKET (NOT SHOWN)
	1	1002067	JAMB – HINGE SIDE
10	1	21A01000-268	ASSY – BAGGAGE DOOR
	1	21A01162-035	COVER - SKIN
	1	21A01741-004	HINGE, BAGGAGE COVER, 3/4
	2	21A01010-012	STIFFENER - DOOR
	2	21A01004-106	STIFFENER ENDS
	2	3A01206-001	RETAINER - LOCK
	2	3A01273-004	LOCK PIN
	2	3A01702-001	CATCH – LATCH
	2	3A01525-003	LOCK SPRING
	2	9-0177A221	RING – OPENING
	1	101438	SEAL – GASKET (NOT SHOWN)
11	1	21A01326-003	TOP RAIL – BAGGAGE OPENING L.
	1	21A01326-002	TOP RAIL – BAGGAGE OPENING R.

PARTS MANUAL
 2100 FLOATS ON CESSNA 170

ITEM	QTY	PART NO.	PART DESCRIPTION
12	2	21A01326-004	JAMB – BAGGAGE DOOR
13	2	21A01203-001	CLEAT – TIE DOWN
	4	21A01280-004	BUSHING
	4	AN525-10R24	SCREW – ATTACH
	4	MS21044N3	NUT, LOCKING, REGULAR HEIGHT, 10-32 UNF
	4	NAS1149D0363J	WASHER, 0.203 ID, 0.063 THK, ALUMINUM

THIS PAGE INTENTIONALLY LEFT BLANK

SECTION 5 EXTRUSIONS

CONTENTS

HULL EXTRUSIONS - AMPHIBIAN	54
HULL EXTRUSIONS - SEAPLANE.....	56

HULL EXTRUSIONS - AMPHIBIAN

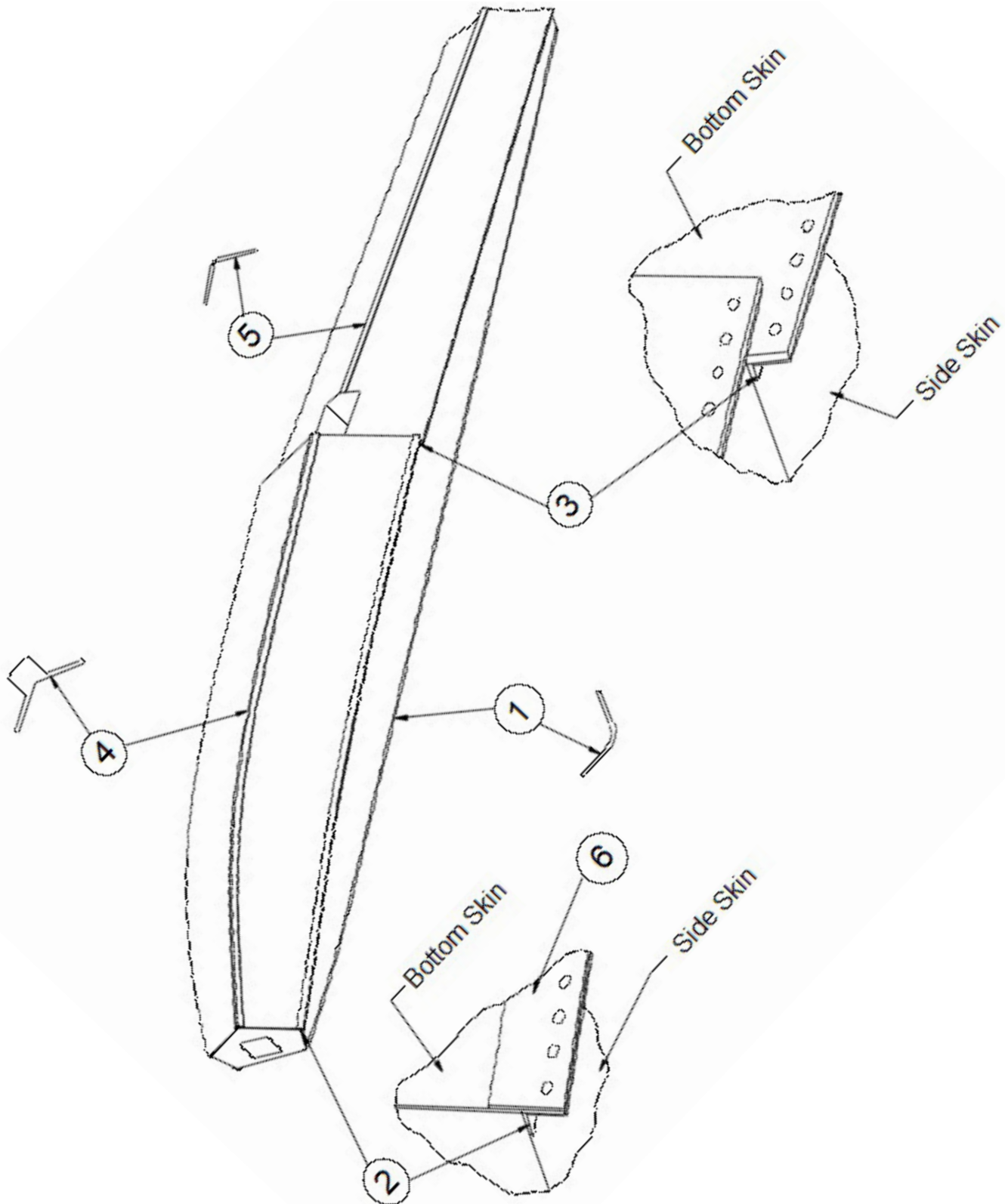

PARTS MANUAL
2100 FLOATS ON CESSNA 170

ITEM	QTY	PART NO.	PART DESCRIPTION
1	1	21A01324-001	GUNWALL – L.
	1	21A01324-002	GUNWALL – R.
2	1	21A01340-109	CHINE - FWD L.
	1	21A01340-108	CHINE – FWD R.
3	1	21A01340-107	CHINE – AFTERBODY L.
	1	21A01340-106	CHINE – AFTERBODY R.
4	1	21A01321-001	KEEL - MAIN
5	1	21A01008-142	KEEL - AFTERBODY

HULL EXTRUSIONS - SEAPLANE

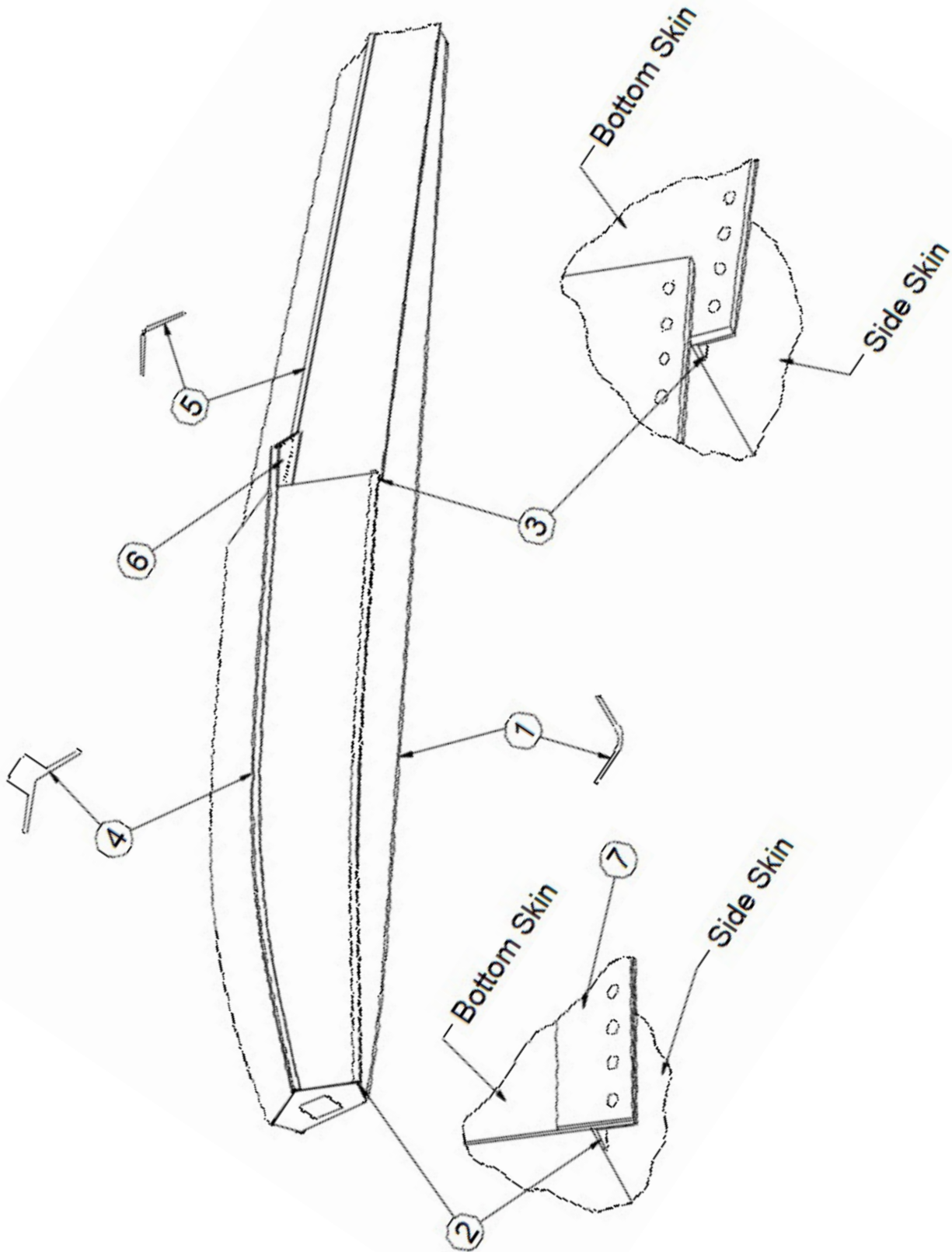

PARTS MANUAL
2100 FLOATS ON CESSNA 170

ITEM	QTY	PART NO.	PART DESCRIPTION
1	1	21A01324-001	GUNWALL – L.
	1	21A01324-002	GUNWALL – R.
2	1	21A01340-109	CHINE - FWD L.
	1	21A01340-108	CHINE – FWD R.
3	1	21A01340-107	CHINE – AFTERBODY L.
	1	21A01340-106	CHINE – AFTERBODY R.
4	1	21S01321-004	KEEL - MAIN
5	1	21S01008-172	KEEL - AFTERBODY
6	1	21S01000-400	AFTERBODY GUSSET ASSY.
	1	21S01163-037	ANGLE SUPPORT – AFTERBODY L.
	1	21S01163-038	ANGLE SUPPORT – AFTERBODY R.

THIS PAGE INTENTIONALLY LEFT BLANK

SECTION 6 PUMPER TUBE INSTALLATION

CONTENTS

PUMPER TUBE.....	60
------------------	----

PUMPER TUBE

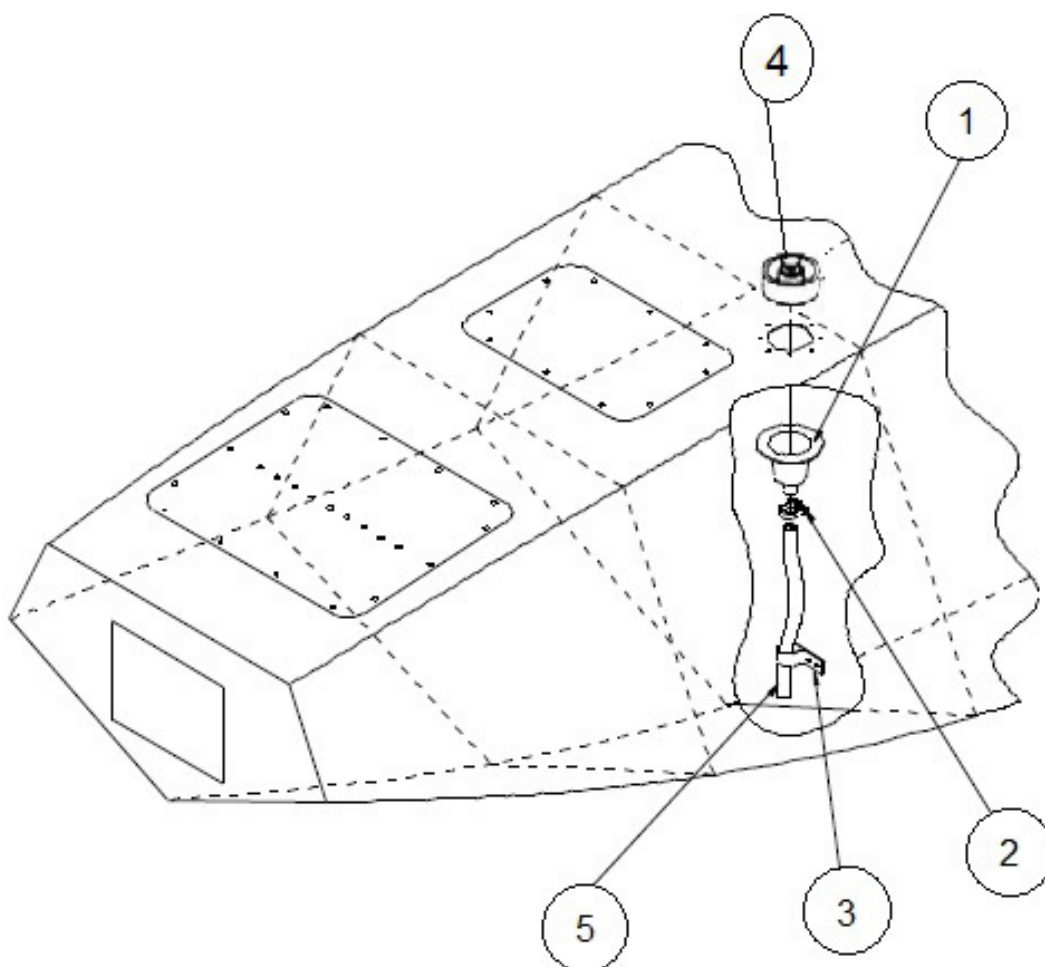

ITEM	QTY	PART NO.	PART DESCRIPTION
1	1	1011004	ASSEMBLY, CUP, PUMPOUT, DUCKBILL
	1	4A01749-001	CUP – PUMPOUT ALUM.
	1	1011808	RETAINER, VALVE, DUCKBILL, PUMPOUT PLUG
2	1	57134	CLAMP – UPPER END
3	1	3A01158-003	CLAMP – LOWER END
4	1	1011870	VALVE, DUCKBILL (NEW VERSION)
	1	2111	STOPPER – PUMPER TUBE
5	1	21A01618-062	PUMPOUT TUBE 10.5 IN.
	1	21A01648-061	PUMPOUT TUBE 12.5 IN.
	1	21A01648-060	PUMPOUT TUBE 15.0 IN.
	1	21A01618-059	PUMPOUT TUBE 17.5 IN.
	1	21A01648-058	PUMPOUT TUBE 23.0 IN.
	1	21A01648-056	PUMPOUT TUBE 21.5 IN.
	1	21A01648-055	PUMPOUT TUBE 18.5 IN.

SECTION 7 WATER RUDDER & RETRACT HANDLE

CONTENTS

WATER RUDDER INSTALLATION	62
RETRACT HANDLE ASSEMBLY	64

WATER RUDDER INSTALLATION

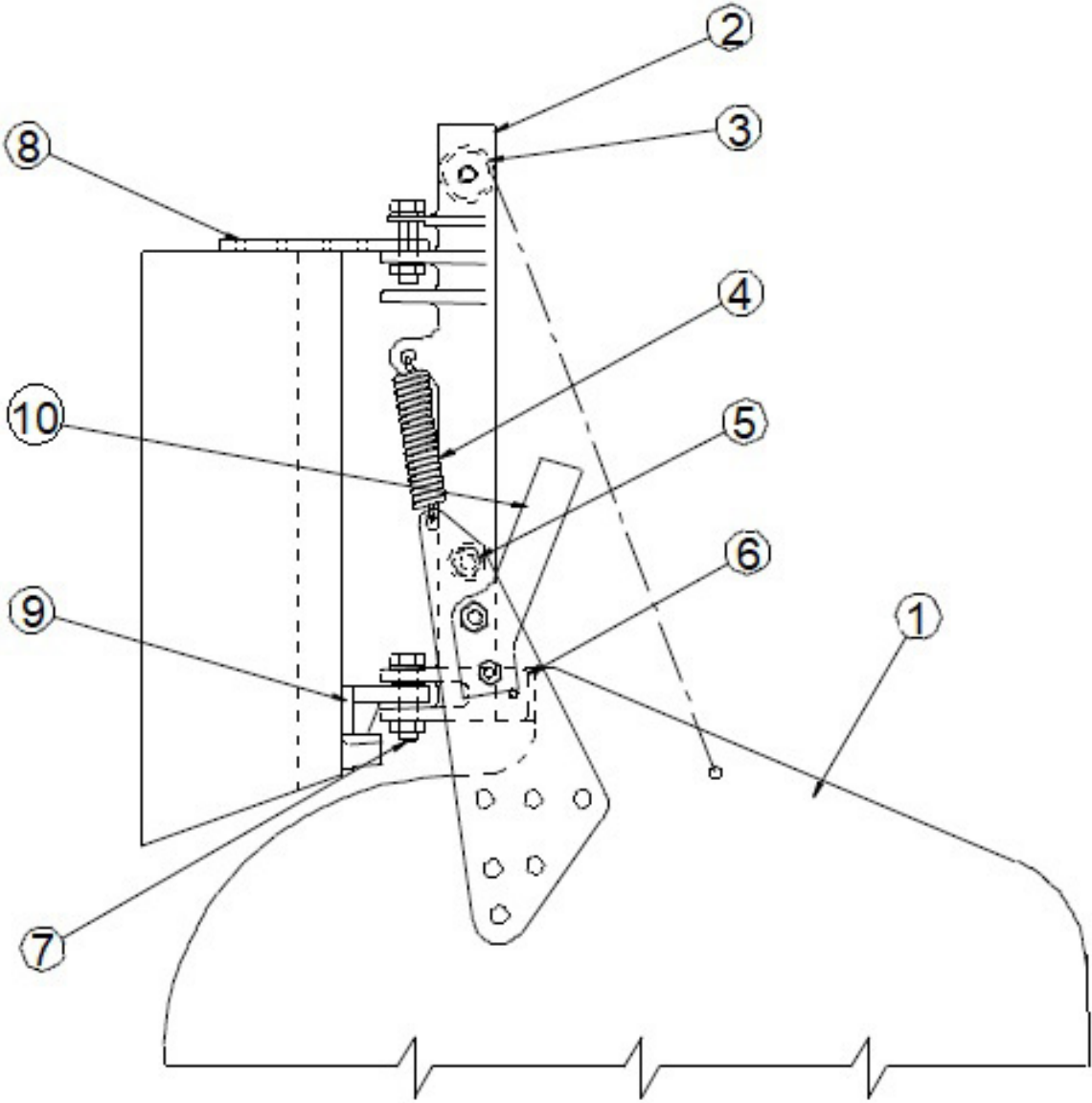

PARTS MANUAL
2100 FLOATS ON CESSNA 170

ITEM	QTY	PART NO.	PART DESCRIPTION
1	1	21A08000-123	ASSY. - BLADE
	1	21A08017-006	BLADE
	1	21A08019-001	ARM L.
	1	21A08019-002	ARM R.
2	1	21A08000-152	ASSY. - POST – WATER RUDDER
	1	21A08442-001	POST – WATER RUDDER
3	1	21A08602-009	GUIDE - RETRACT
	1	5/16 X 1-1/2	PIN – ATTACH
4	2	21A08525-006	SPRING
5	1	AN5-26A	BOLT, 5/16-24, 2.3125 GRIP, UNDRILLED, STEEL
	1	NAS1149D0516J	WASHER, 0.328 ID, 0.016 THK, ALUMINUM
	1	MS21083N5	NUT, LOCKING, LOW HEIGHT, 5/16-24 UNF
6	1	21A08648-002	BUMPER – DOWN STOP
	1	1001457	ROLL PIN
7	2	AN5-12A	BOLT, SIZE 5/16-24, LENGTH 1/64 - 1-11/32, GRIP LENGTH 13/16
	4	NAS1149D0516J	WASHER, 0.328 ID, 0.016 THK, ALUMINUM
	2	MS21083N5	NUT, LOCKING, LOW HEIGHT, 5/16-24 UNF
8	1	21A01000-299	ASSY. – TOP BEARING
	1	21A01019-003	PLATE
	1	21A01705-003	BEARING
9	1	21A08000-157	ASSY. – LOWER BEARING
	1	21A08318-002	BRACKET
	1	05DU06	BEARING
10	2	21A08154-009	STOP
	2	AN4-7A	BOLT, 1/4-28, 0.4375 GRIP, UNDRILLED, STEEL
	2	NAS1149D0463J	WASHER, 0.265 ID, 0.063 THK, ALUMINUM
	2	MS21044N4	NUT, LOCKING, REGULAR HEIGHT, 1/4-28 UNF
	2	AN3-7A	BOLT, 10-32, 0.5 GRIP, UNDRILLED, STEEL
	2	NAS1149D0363J	WASHER, 0.203 ID, 0.063 THK, ALUMINUM
	2	MS21044N3	NUT, LOCKING, REGULAR HEIGHT, 10-32 UNF

RETRACT HANDLE ASSEMBLY

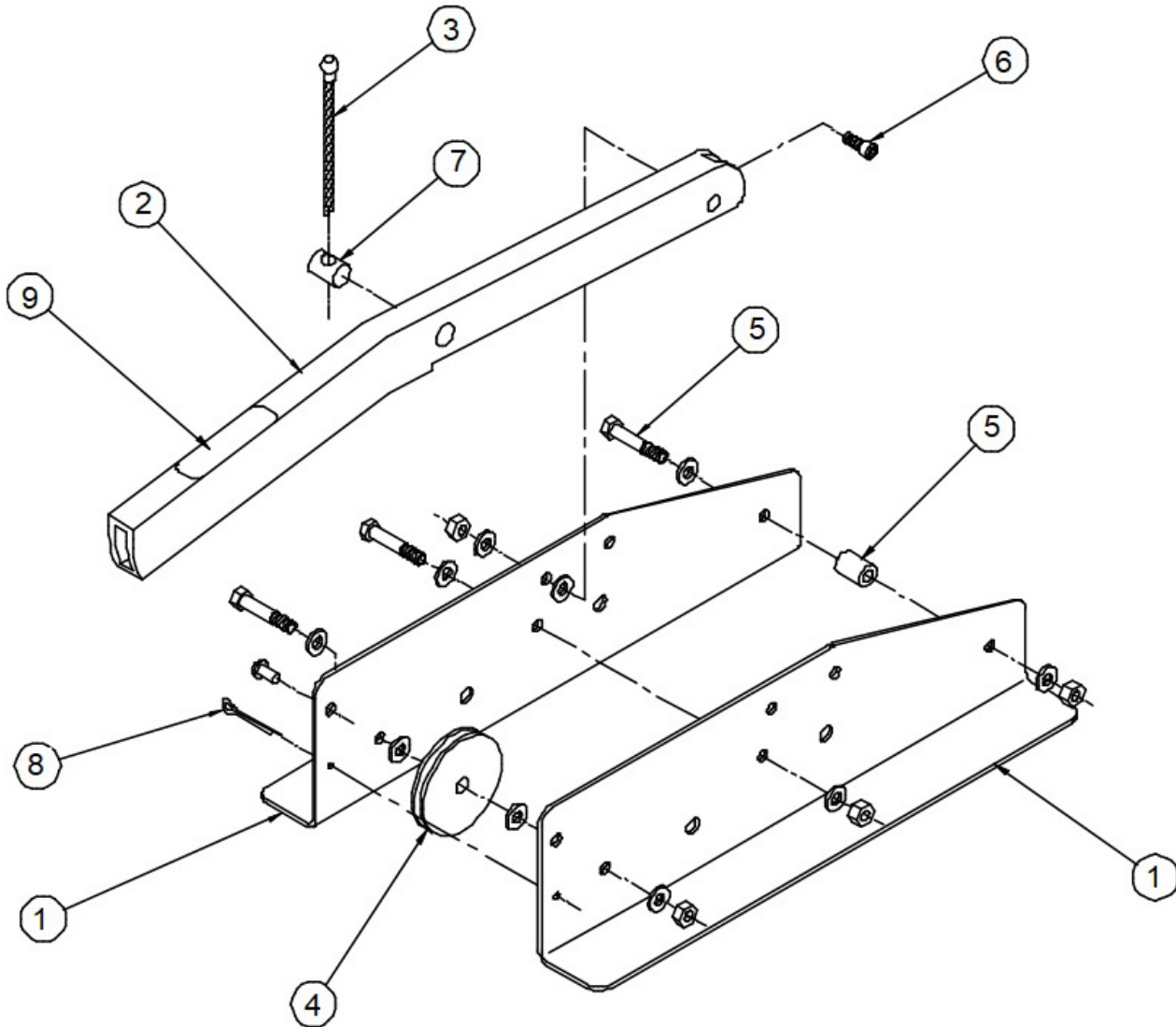

PARTS MANUAL
2100 FLOATS ON CESSNA 170

ITEM	QTY	PART NO.	PART DESCRIPTION
1	1	21A08000-128	ASSY. – RETRACT HANDLE
	1	3A08003-015	BRACKET SIDE L.
	1	3A08003-016	BRACKET SIDE R.
2	1	3A08414-001	HANDLE
3	1	21A08000-137	CABLE ASSY.
4	1	MS20219-2	PULLEY
	1	AN4-10A	BOLT, 1/4-28, 0.5625 GRIP, UNDRILLED, STEEL
	2	NAS1149D0463J	WASHER, 0.265 ID, 0.063 THK, ALUMINUM
	1	NAS679A4W	KAYNAR NUT
5	2	AN3-10A	BOLT, 10-32, 0.625 GRIP, UNDRILLED, STEEL
	2	3A08613-001	BUSHING – PLASTIC
	4	NAS1149D0316J	WASHER, 0.203 ID, 0.016 THK, ALUMINUM
	2	NAS679A3W	KAYNAR NUT
6	2	3A08702-006	PIN PIVOT
	2	NAS1149D0316J	WASHER, 0.203 ID, 0.016 THK, ALUMINUM
	2	NAS679A3W	KAYNAR NUT
7	1	4A08506-002	SWIVEL
8	1	MS24665-285	PIN – COTTER
9	1	3A3-1115-2	PLACARD – DOWN
	1	3A3-1115-3	PLACARD – UP
	1	3A3-1115-1	PLACARD – WATER RUDDER CONTROL

THIS PAGE INTENTIONALLY LEFT BLANK

SECTION 8 LANDING GEAR

CONTENTS

NOSE GEAR RETRACTION ASSEMBLY	68
NOSE GEAR LOWER ASSEMBLY	71
NOSE WHEEL ASSEMBLY (GROVE)	73
NOSE WHEEL ASSEMBLY (PARKER)	75
MAIN GEAR RETRACTION INSTALLATION.....	77
MAIN GEAR WHEEL GROVE / WIPAIRE ASSEMBLY	80
MAIN GEAR WHEEL CLEVELAND / PARKER ASSEMBLY	82

NOSE GEAR RETRACTION ASSEMBLY

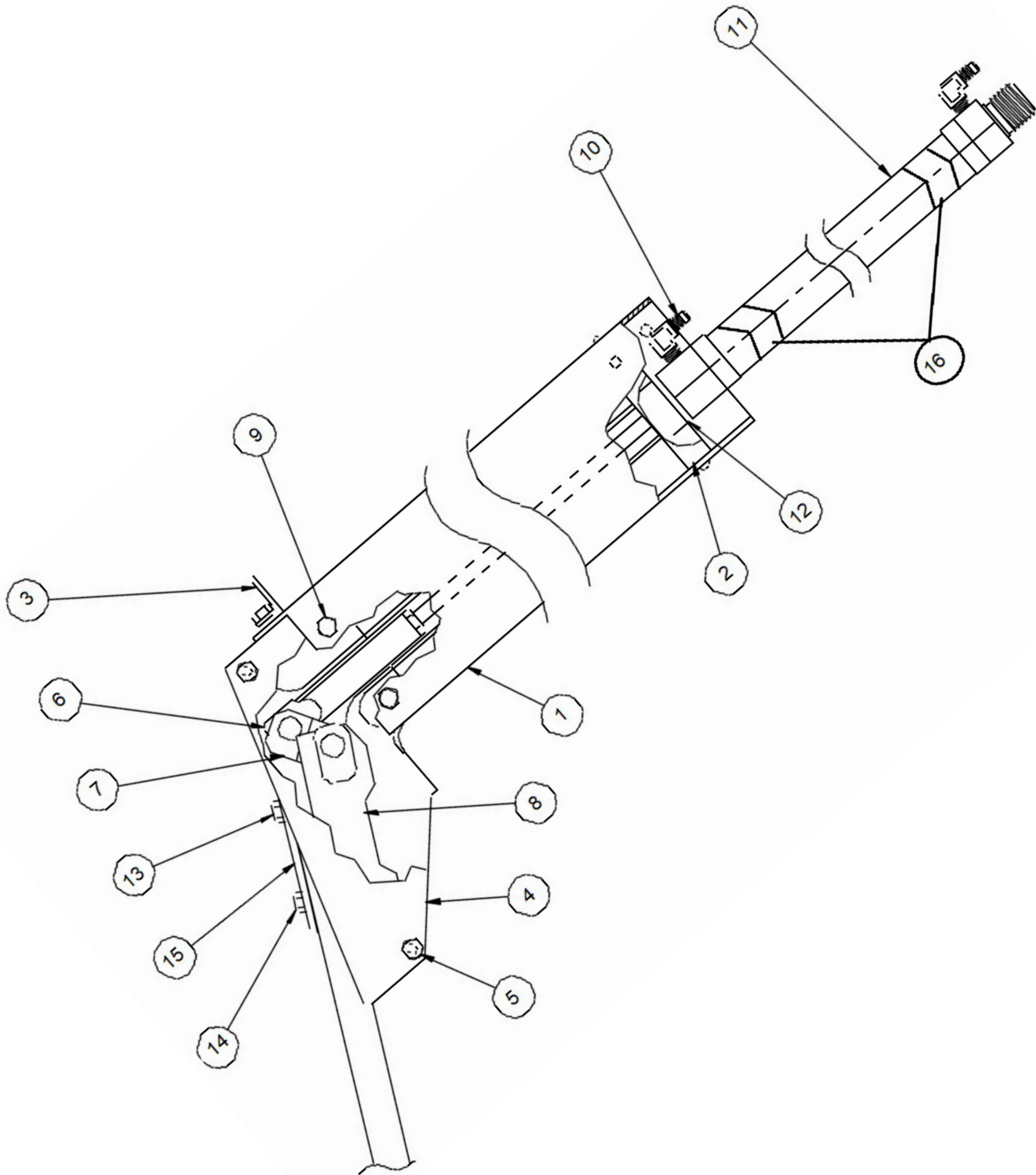

PARTS MANUAL
2100 FLOATS ON CESSNA 170

ITEM	QTY	PART NO.	PART DESCRIPTION
1	1	21A07000-015	ASSY. – NOSE BOX
	1	21A07323-001	NOSE – BOX
	1	8A01008-080	COVER, BULKHEAD HYD CYL. HOLE
	1	30A07567-011	GASKET
	4	AN526-1032R4	SCREW, TRUSS HEAD MACHINE, 10-32 THREAD, 1/4" LENGTH
2	1	21A07237-002	END – CAP - AFT
3	1	21A07359-194	ANGLE
	2	AN4-6A	BOLT, 1/4-28, 0.3125 GRIP, UNDRILLED, STEEL
	2	NAS1149D0463J	WASHER, 0.265 ID, 0.063 THK, ALUMINUM
	2	NAS1149D0416J	WASHER, 0.265 ID, 0.016 THK, ALUMINUM
	2	MS21044N4	NUT, LOCKING, REGULAR HEIGHT, 1/4-28 UNF
4	1	21A07349-003	TRACK – NOSE END L.
	1	21A07349-004	TRACK – NOSE END R.
5	2	AN4-53A	BOLT, 1/4-28 THREAD, 4-15/16" GRIP, 5-13/32 LENGTH
	4	NAS1149D0416J	WASHER, 0.265 ID, 0.016 THK, ALUMINUM
	2	NAS5679-A4W	NUT
6	1	21A07094-002	ROD END - RAM
	1	AN316-5R	NUT JAM, HEXAGON, 5/16-24 THREAD, RIGHT
7	1	21A07032-005	LINK – DOWN LOCK
	1	21A07509-007	AXLE – SHAFT
	2	3A07530-001	ROLLER
	2	5100-46-H	SNAP RING
8	1	21A07187-009	TROLLEY – SPRING ATTACH
	2	34A07509-008	AXLES - SHAFT
	4	3A07604-001	BLOCK - SLIDE
9	4	AN4-5A	BOLT, 1/4-28, 0.1875 GRIP, UNDRILLED, STEEL
	4	NAS1149D0463J	WASHER, 0.265 ID, 0.063 THK, ALUMINUM
	8	NAS1149D0416J	WASHER, 0.265 ID, 0.016 THK, ALUMINUM
	4	NAS5679-A4W	NUT
10	2	MS20822-4D	ELBOW FITTING, 90 DEG, 7/16-20 TUBE, 5-44 PIPE
11	1	1002571	HYDRAULIC CYLINDER
12	A/R	NAS1149D1416J	WASHER, AIRFRAME, ALUMINUM, TO FIT DIA 1/4"
13	2	AN5-20A	BOLT, 5/16-24, 1.5625 GRIP, UNDRILLED, STEEL
	A/R	NAS1149F0563P	WASHER, 0.328 ID, 0.063 THK, STEEL
	2	MS21044N5	NUT, LOCKING, REGULAR HEIGHT, 5/16-24 UNF
14	2	AN5-21A	BOLT, 5/16-24, 1.6875 GRIP, UNDRILLED, STEEL
	A/R	NAS1149F0563P	WASHER, 0.328 ID, 0.063 THK, STEEL
	2	MS21044N5	NUT, LOCKING, REGULAR HEIGHT, 5/16-24 UNF
15	1	21A06166-001	PLATE – BEARING UPPER
	2	21A09005-262	CLIP-MAGNETIC INDICATOR (NOT SHOWN)
	2	5801	PROXIMITY SWITCH (NOT SHOWN)

ITEM	QTY	PART NO.	PART DESCRIPTION
	4	MS24693-S6	SCREW, COUNTERSUNK , 4-40 UNC, 0.5 LG (NOT SHOWN)
16	2	3A07005-178	CLIP, SWITCH, NOSE & MAIN

NOSE GEAR LOWER ASSEMBLY

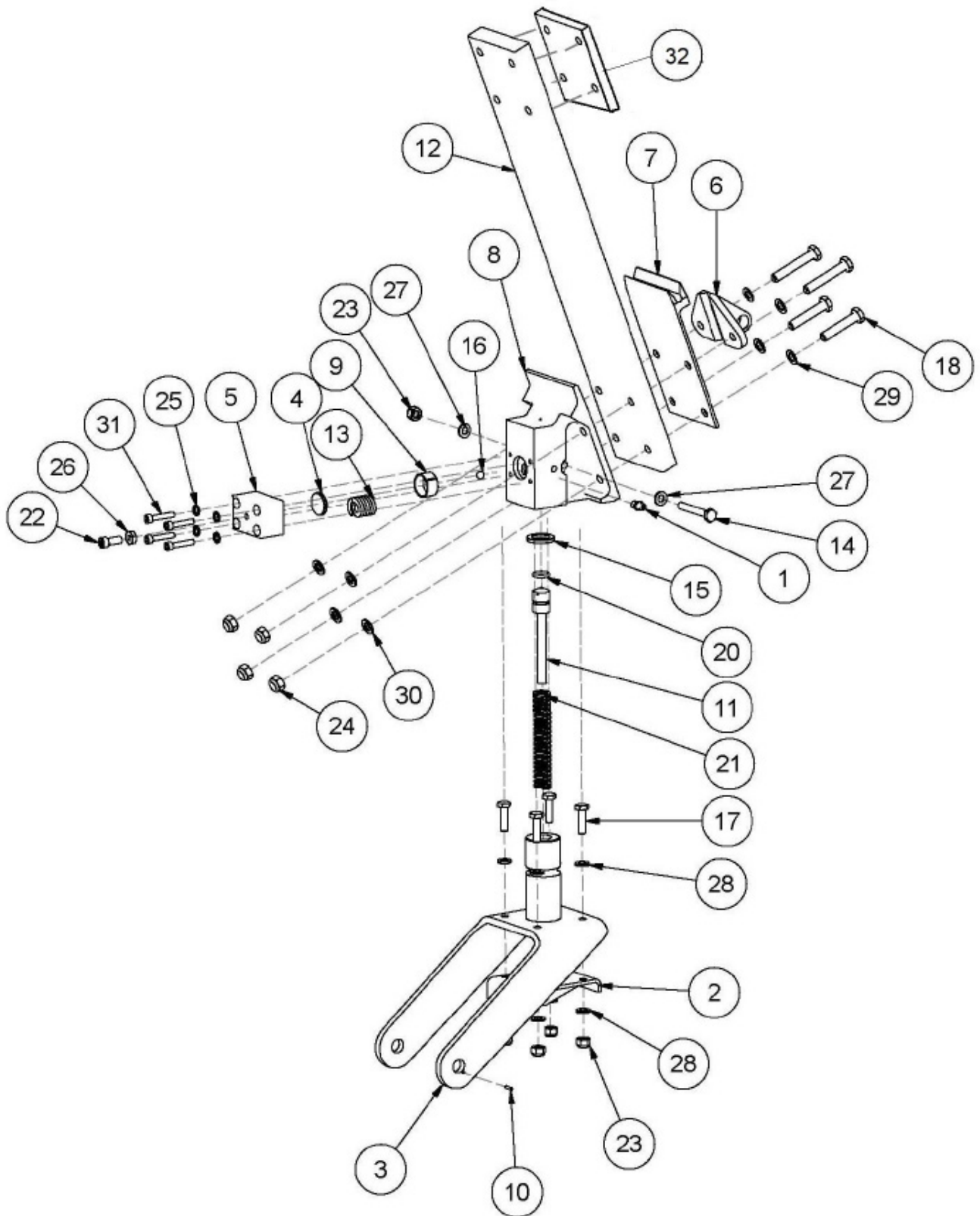

ITEM	QTY	PART NO.	PART DESCRIPTION
1	1	1095K41	COMMON GREASEZERK
2	1	21A06000-020	WELDMENT, PIVOT SHAFT, FORK, NOSE GEAR
3	1	21A06020-001	FORK, NOSE GEAR (2100)
4	1	21A06160-053	PRESSURE PLATE
5	1	21A06194-005	BLOCK - SPRING
6	1	21A06213-006	TOW HOOK NOSE GEAR
7	1	21A06237-001	BEARING PLATE, LOWER, NOSE GEAR
8	1	21A06318-005	BLOCK - PIVOT, NOSE GEAR
9	1	21A06475-006	FRICITION CUP
10	1	21A06476-003	PIN, ANTIROTATION
11	1	21A06605-002	PLUNGER- NOSE WHEEL, 21, 23,3,34
12	1	21A06653-001	SPRING NOSE GEAR
13	1	21A06705-005	PRESSURE SPRING
14	1	30A06702-016	BOLT - MODIFIED, PIVOT BLOCK
15	1	3A06602-001	THRUST WASHER
16	1	9528K15	1/4" CHROME BALL BEARING
17	4	AN4-7A	BOLT, 1/4-28, 0.4375 GRIP, UNDRILLED, STEEL
18	2	AN5-14A	BOLT, 5/16-24, 1.0625 GRIP, UNDRILLED, STEEL
19	2	AN5-16A	BOLT, 5/16-24 THREAD, 1-5/16" GRIP, 1-27/32" LENGTH
20	1	AN6227-9	O-RING
21	1	M62-350	SPRING
22	1	MS16997-60	SOCKET HEAD CAP SCREW
23	5	MS21044N4	NUT, LOCKING, REGULAR HEIGHT, 1/4-28 UNF
24	4	MS21044N5	NUT, LOCKING, REGULAR HEIGHT, 5/16-24 UNF
25	4	MS35333-39	LOCKWASHER, INTERNAL TOOTH, TO FIT DIA #10
26	1	MS35649-2252	NUT, PLAIN HEXAGON, 1/4-20 THREAD
27	2	NAS1149D0463J	WASHER, 0.265 ID, 0.063 THK, ALUMINUM
28	8	NAS1149F0463P	WASHER, 0.265 ID, 0.063 THK, STEEL
29	4	NAS1149F0532P	WASHER, 0.328 ID, 0.032 THK, STEEL
30	4	NAS1149F0563P	WASHER, 0.328 ID, 0.063 THK, STEEL
31	4	NAS1352-316P	SOCKET HEAD CAP SCREW
32	1	21A06166-001	PLATE - BEARING, NOSE SPRING
	4	AN5-20A	BOLT, 5/16-24, 1.5625 GRIP, UNDRILLED, STEEL (NOT SHOWN)
	4	NAS1149F0563P	WASHER, 0.328 ID, 0.063 THK, STEEL (NOT SHOWN)
	4	MS21044N5	NUT, LOCKING, REGULAR HEIGHT, 5/16-24 UNF (NOT SHOWN)

NOSE WHEEL ASSEMBLY (GROVE)

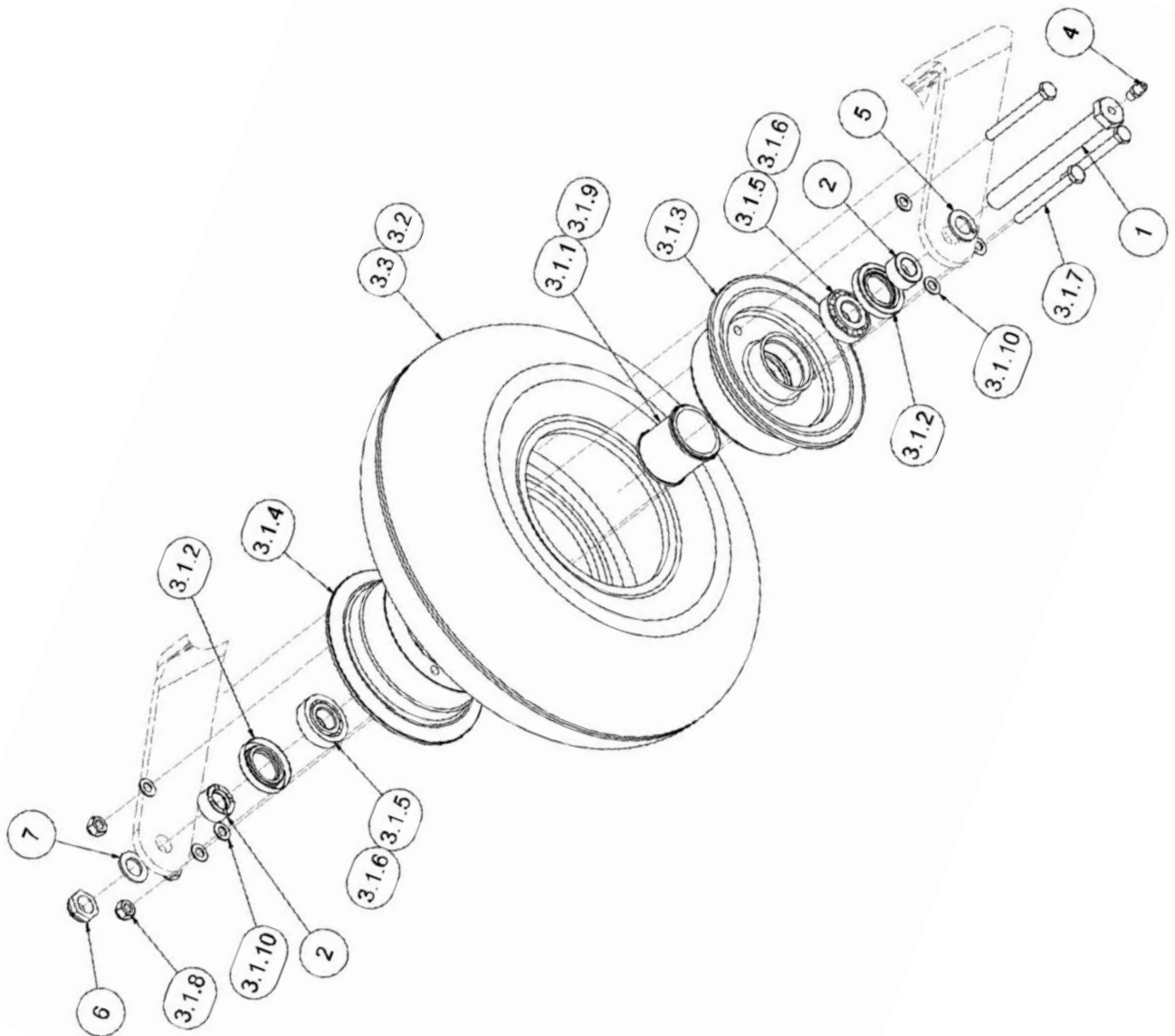

ITEM	QTY	PART NO.	PART DESCRIPTION
1	1	1005927	BOLT, AXLE, NOSE GEAR
2	2	1005929	SPACER
3	1	1005931	ASSEMBLY, NOSE WHEEL
3.1	1	49-12AF-001	ASSEMBLY, WHEEL, GROVE
3.1.1	1	010-019	GREASE RETAINER
3.1.2	2	471570	SEAL, TIMKEN (EQUIVALENT TO GROVE OEM P/N 010-026)
3.1.3	1	015-020A	WHEEL HALF INNER
3.1.4	1	016-020AF	WHEEL HALF OUTER
3.1.5	2	A4050	BEARING CORE
3.1.6	2	A4138	BEARING CONE
3.1.7	3	AN4-23A	BOLT, 1/4-28, 1.9375 GRIP, UNDRILLED, STEEL
3.1.8	3	MS21044N4	NUT, LOCKING, REGULAR HEIGHT, 1/4-28 UNF
3.1.9	2	MS28775-029	O RING, I.D 1.489, O.D. 1.629. .070 THICK
3.1.10	6	NAS1149F0416	WASHER, 0.265 ID, 0.016 THK, STEEL
3.2	1	XA1AA*	INNER TUBE, 2.80 X 4
3.3	1	AD1A2*	TIRE, 2.50 / 2.80 - 4
4	1	1095K41	COMMON GREASEZERK
5	1	3A06702-003	MODIFIED WASHER
6	1	MS21083N8	NUT, 1/2-20 THREAD, LOW HEIGHT, NYLON INSERT, 250 DEG.
7	1	NAS1149D0863J	WASHER, 0.515 ID, 0.063 THK, ALUMINUM

* Any alternate tire (tube type) which is TSO-approved, matches the listed tire's dimensions, and meets its speed/load/ply ratings may be used. Equivalent tubes may also be used.

NOSE WHEEL ASSEMBLY (PARKER)

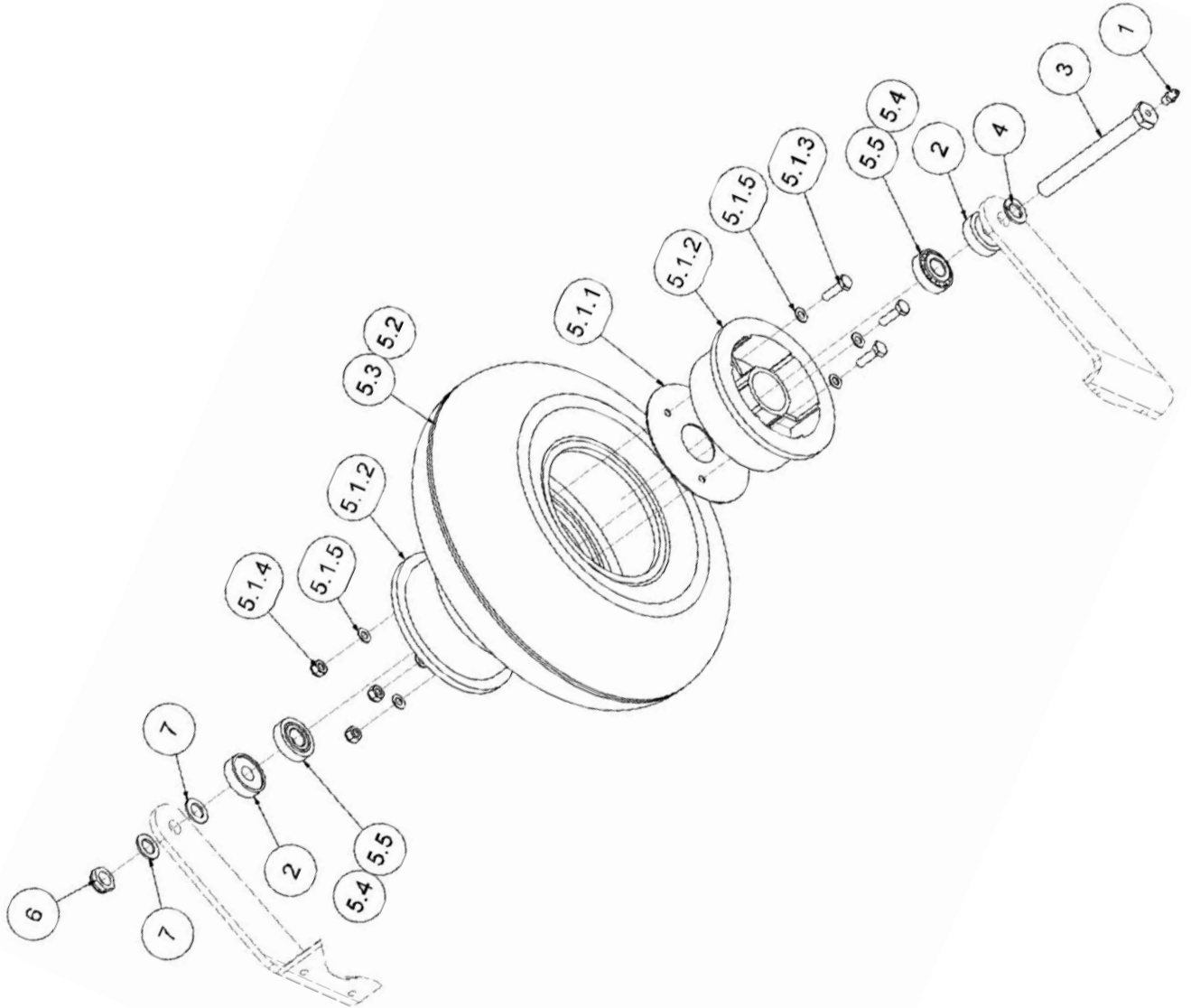

ITEM	QTY	PART NO.	PART DESCRIPTION
1	1	1095K41	COMMON GREASEZERK
2	2	3A06259-001	SPACER
3	1	3A06702-002	BOLT, MODIFIED, AXLE, NOSE GEAR
4	1	3A06702-003	MODIFIED WASHER
5	1	21A06000-021	NOSE WHEEL ASSEMBLY
5.1	1	D-30380	PARKER WHEEL ASSEMBLY
5.1.1	1	068-30373	GASKET
5.1.2	2	161-30382	WHL HALF ASSY, 4 INCH
5.1.3	3	AN4-7A	BOLT, 1/4-28, 0.4375 GRIP, UNDRILLED, STEEL
5.1.4	3	MS21044N4	NUT, LOCKING, REGULAR HEIGHT, 1/4-28 UNF
5.1.5	6	NAS1149F0432P	WASHER, 0.265 ID, 0.032 THK, STEEL
5.2	1	XA1AA*	INNER TUBE, 2.80 X 4
5.3	1	AD1A2*	TIRE, 2.50 / 2.80 - 4
5.4	2	A4050	BEARING CORE
5.5	2	A4138	BEARING CONE
6	1	MS21083N8	NUT, 1/2-20 THREAD, LOW HEIGHT, NYLON INSERT, 250 DEG.
7	2	NAS1149D0863J	WASHER, 0.515 ID, 0.063 THK, ALUMINUM

* Any alternate tire (tube type) which is TSO-approved, matches the listed tire's dimensions, and meets its speed/load/ply ratings may be used. Equivalent tubes may also be used.

MAIN GEAR RETRACTION INSTALLATION

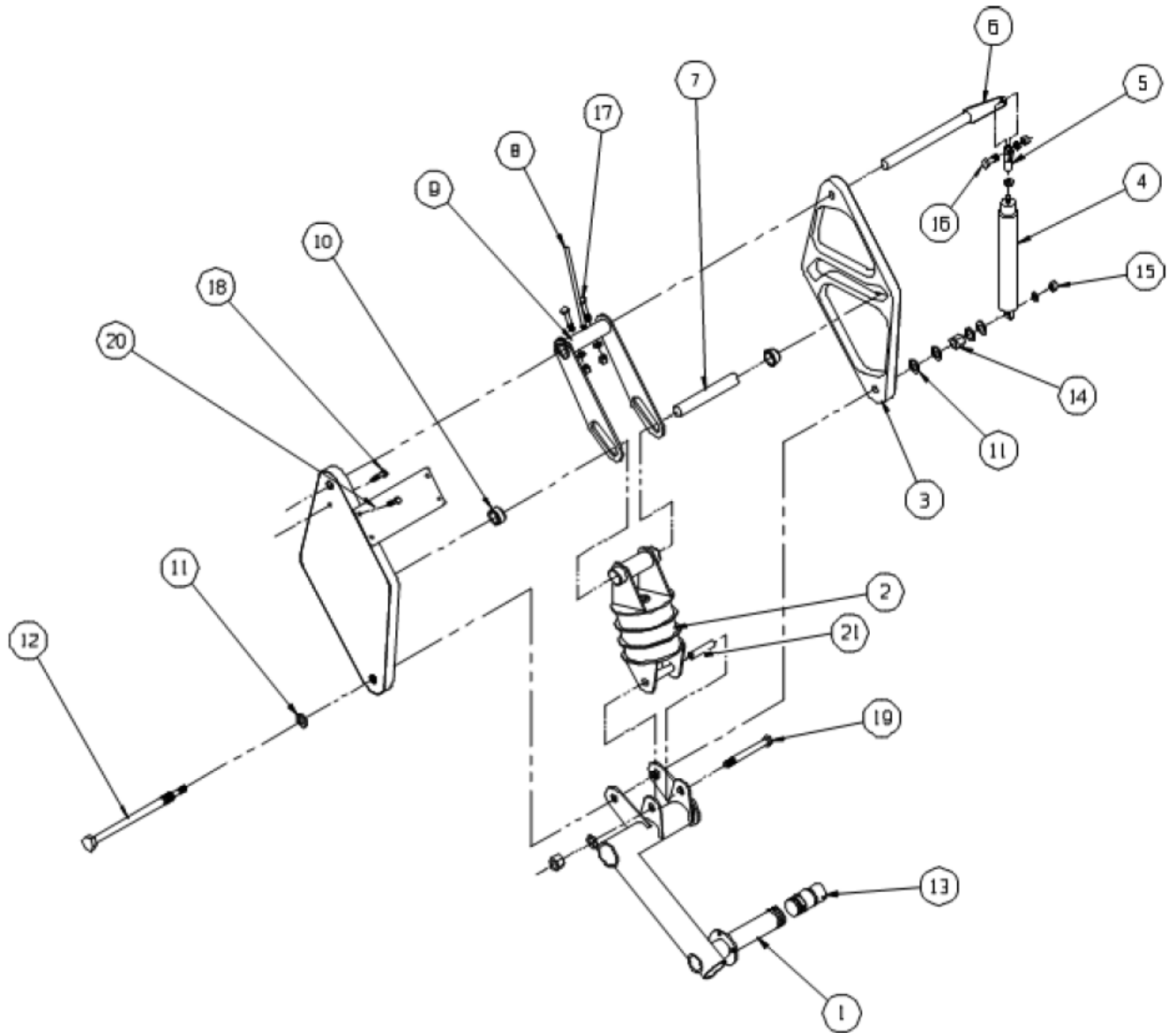

ITEM	QTY	PART NO.	PART DESCRIPTION
1	1	21A04000-077	ASSY. – DRAG LINK L.
	1	21A04000-076	ASSY. – DRAG LINK R.
	2	08FDU10	BEARING
2	1	21A04000-073	ASSY. SHOCK STRUT
	1	21A04000-075	ASSY. – LOWER END
	2	1095K41	ZERK – GREASE
	2	NAS1149D0416J	WASHER, 0.265 ID, 0.016 THK, ALUMINUM
	2	NAS1149D0463J	WASHER, 0.265 ID, 0.063 THK, ALUMINUM
	1	1002087	DUAL BUSHING ASSEMBLY
	1	1001100	BUSHING ASSEMBLY
	1	21A04503-004	RETAINING PIN
	1	MS24665-151	COTTER PIN
	1	21A04585-002	SLEEVES
3	1	21A05114-005	TRACK – MAIN GEAR L.
	1	21A05114-006	TRACK – MAIN GEAR R.
	1	10DU12	BEARING - UPPER
	1	08DU12	BEARING – LOWER
4	1	1002574	CYLINDER
	2	MS20822-4D	FITTING - ELBOW
5	1	21A05705-002	ROD END
	1	AN316-5	JAMB NUT
	1	21A05260-005	SPACER
	1	MS20002C6	WASHER, FIT DIA 3/8", COUNTERSUNK (CHAMFERED EDGE GOES AGAINST CYLINDER)
6	1	21A05000-017	ARM – RETRACT L.
	1	21A05000-016	ARM – RETRACT R.
7	1	21A04454-006	AXLE – SHOCK STRUT
8	1	21A05000-022	INDICTATOR ASSY.
9	1	21A05000-018	GEAR ACTUATOR
10	2	21A05520-003	ROLLER – TRACK
11	2	93783A033	WASHER – SEALING
12	1	21A05000-019	BOLT, MAIN GEAR
	1	21A05735-001	BOLT
	1	21A05476-002	STUD
13	1	21A04263-007	RETAINER - GREASE
	2	MS28775-210	O RING, DIA 0.734
	1	1095K41	ZERK – GREASE
14	1	MS21044N8	NUT, LOCKING, REGULAR HEIGHT, 1/2-20 UNF
	2	NAS1149F0863P	WASHER, CARBON STEEL, TO FIT DIA 1/2"
15	1	MS21083N5	NUT, LOCKING, LOW HEIGHT, 5/16-24 UNF
	A/R	NAS1149F0563P	WASHER, 0.328 ID, 0.063 THK, STEEL

PARTS MANUAL
2100 FLOATS ON CESSNA 170

ITEM	QTY	PART NO.	PART DESCRIPTION
16	1	1005875	ASSEMBLY, PIN, CLEVIS, MAGNET HOLDER
	2	NAS1149F0563P	WASHER, 0.328 ID, 0.063 THK, STEEL
	1	MS21044N5	NUT, LOCKING, REGULAR HEIGHT, 5/16-24 UNF
17	2	NAS6204-17	BOLT, 1/4-28 THREAD, 1.432" LENGTH, 1.062" GRIP
	4	NAS1149D0416J	WASHER, 0.265 ID, 0.016 THK, ALUMINUM
	2	MS21044N4	NUT, LOCKING, REGULAR HEIGHT, 1/4-28 UNF
18	8	AN3-6A	BOLT, 10-32, 0.375 GRIP, UNDRILLED, STEEL
	8	NAS1149D0316J	WASHER, 0.203 ID, 0.016 THK, ALUMINUM
	8	NAS1149D0363J	WASHER, 0.203 ID, 0.063 THK, ALUMINUM
	8	MS21044N3	NUT, LOCKING, REGULAR HEIGHT, 10-32 UNF
19	1	AN8-33A	BOLT, 1/2-20 THREAD, 2-11/16" GRIP, 3-15/32" LENGTH
	1	NAS1149F0832P	WASHER, 0.515 ID, 0.032 THK, STEEL
	1	NAS1149F0863P	WASHER, CARBON STEEL, TO FIT DIA 1/2"
	1	MS21044N8	NUT, LOCKING, REGULAR HEIGHT, 1/2-20 UNF
20	1	21A05003-079	PLATE - SEPARATING
	4	AN3-5A	BOLT, 10-32, 0.25 GRIP, UNDRILLED, STEEL
	8	NAS1149D0316J	WASHER, 0.203 ID, 0.016 THK, ALUMINUM
	4	MS21044N3	NUT, LOCKING, REGULAR HEIGHT, 10-32 UNF
21	1	21A04547-004	BUSHING, LOWER, SHOCK STRUT
	2	21A09005-262	CLIP, MAGNETIC INDICATOR (NOT SHOWN)
	2	5801	PROXIMITY SWITCH (NOT SHOWN)
	4	MS24693-S6	SCREW, COUNTERSUNK , 4-40 UNC, 0.5 LG (NOT SHOWN)

MAIN GEAR WHEEL GROVE / WIPAIRE ASSEMBLY

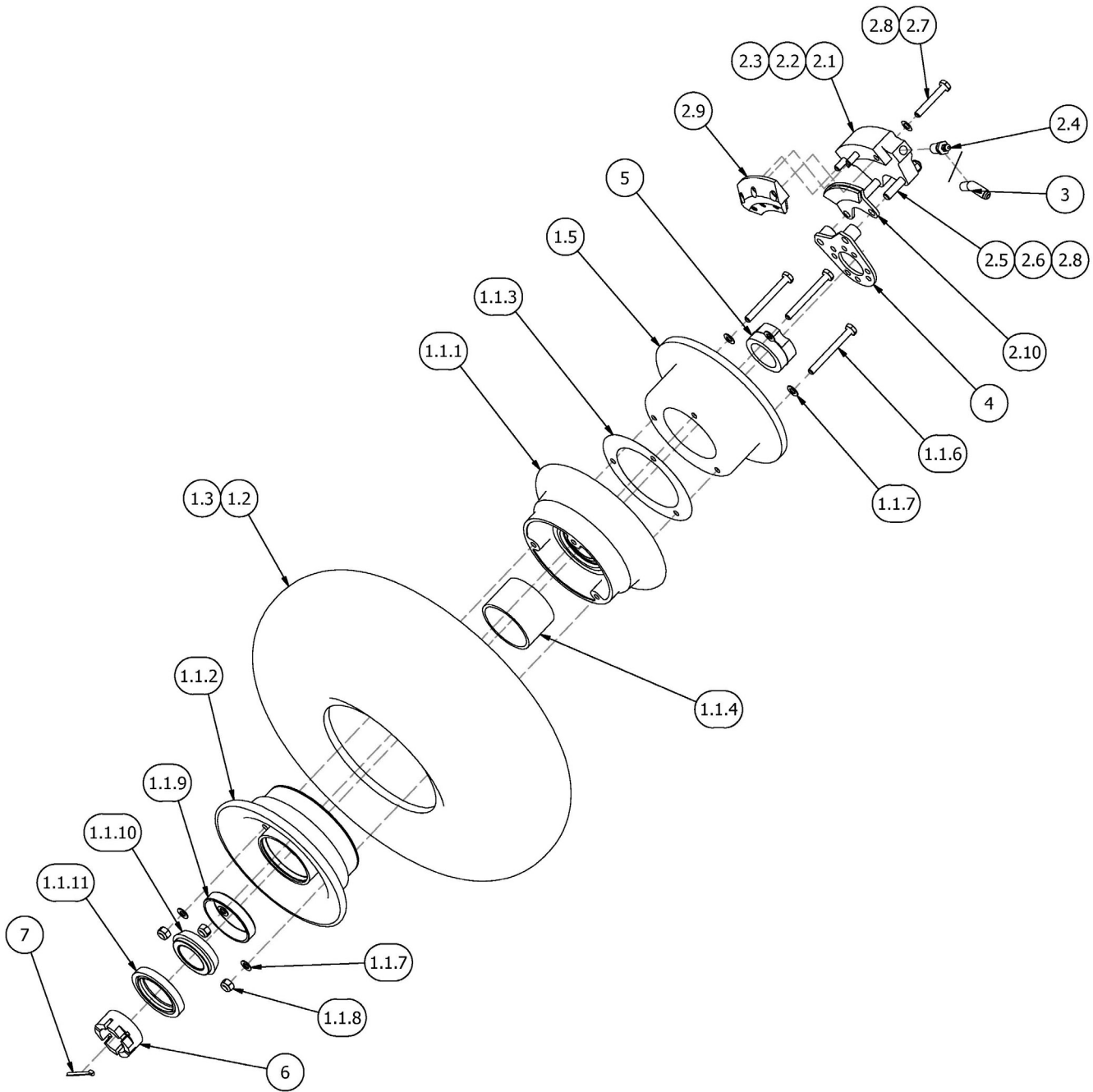

ITEM	QTY	PART NO.	PART DESCRIPTION
1	1	1002141	ASSY, MAIN WHEEL, GROVE, 2100 (INCLUDES TIRE AND TUBE)
1.1	1	1002142	ASSY, RIM & BEARINGS, GROVE, 2100
1.1.1	1	015-002	WHEEL HALF, INNER (REF)
1.1.2	1	016-002	WHEEL HALF, OUTER (REF)
1.1.3	1	3A04620-001	GASKET - TEFLON
1.1.4	1	010-009	GREASE RETAINER
1.1.5	1	018-001	BRAKE DISC (NOMINAL THICKNESS 0.190", MINIMUM 0.165")
1.1.6	3	AN4-23A	BOLT, 1/4-28, 1.9375 GRIP, UNDRILLED, STEEL
1.1.7	6	NAS1149F0432P	WASHER, 0.265 ID, 0.032 THK, STEEL
1.1.8	3	MS21044N4	NUT, LOCKING, REGULAR HEIGHT, 1/4-28 UNF
1.1.9	2	08231	BEARING CUP
	-	08231CP	BEARING CUP (CHROME, REF)
1.1.10	2	08125	BEARING CONE
	-	08125CP	BEARING CONE (CHROME, REF)
1.1.11	2	473237	SEAL - INSIDE/OUTSIDE
1.2	1	AA1D4*	TIRE -TYPE III 5.00 X 5, 6 PLY
1.3	1	XA1AC*	TUBE 5.00 X 5
2	1	32-1	BRAKE ASSEMBLY
2.1	1	023-005	CALIPER BODY (REF)
2.2	2	017-003	PISTON (REF)
2.3	2	MS28775-217	O-RING, HYDRAULIC
2.4	1	220-0063	BLEEDER ASSEMBLY
2.5	2	013-001	TORQUE PIN (REF)
2.6	2	MS21044N4	NUT, LOCKING, REGULAR HEIGHT, 1/4-28 UNF
2.7	3	AN4H-15A	BOLT
2.8	5	NAS1149F0416P	WASHER, 0.265 ID, 0.016 THK, STEEL
2.9	1	10-3	ASS'Y - BACK PLATE (REF)
2.9.1	1	RA66-111	LINING (PAD)
2.9.2	3	066-001	RIVET
	A/R	105-00200 (ALT)	RIVET (ALTERNATE PN)
2.10	1	11-2	ASS'Y - PRESSURE PLATE
2.10.1	1	RA66-111	LINING (PAD)
2.10.2	3	066-001	RIVET
	3	105-00200 (ALT)	RIVET (ALTERNATE PN)
3	1	MS20823-3D	FITTING 45° BRAKE LINE
4	1	020-001	BRAKE TORQUE PLATE
5	1	3A04093-001	SPACER
6	1	3A04268-003	NUT - AXLE
7	1	MS24665-351	COTTER PIN

* Any alternate tire (tube type) which is TSO-approved, matches the listed tire's dimensions, and meets its speed/load/ply ratings may be used. Equivalent tubes may also be used.

MAIN GEAR WHEEL CLEVELAND / PARKER ASSEMBLY

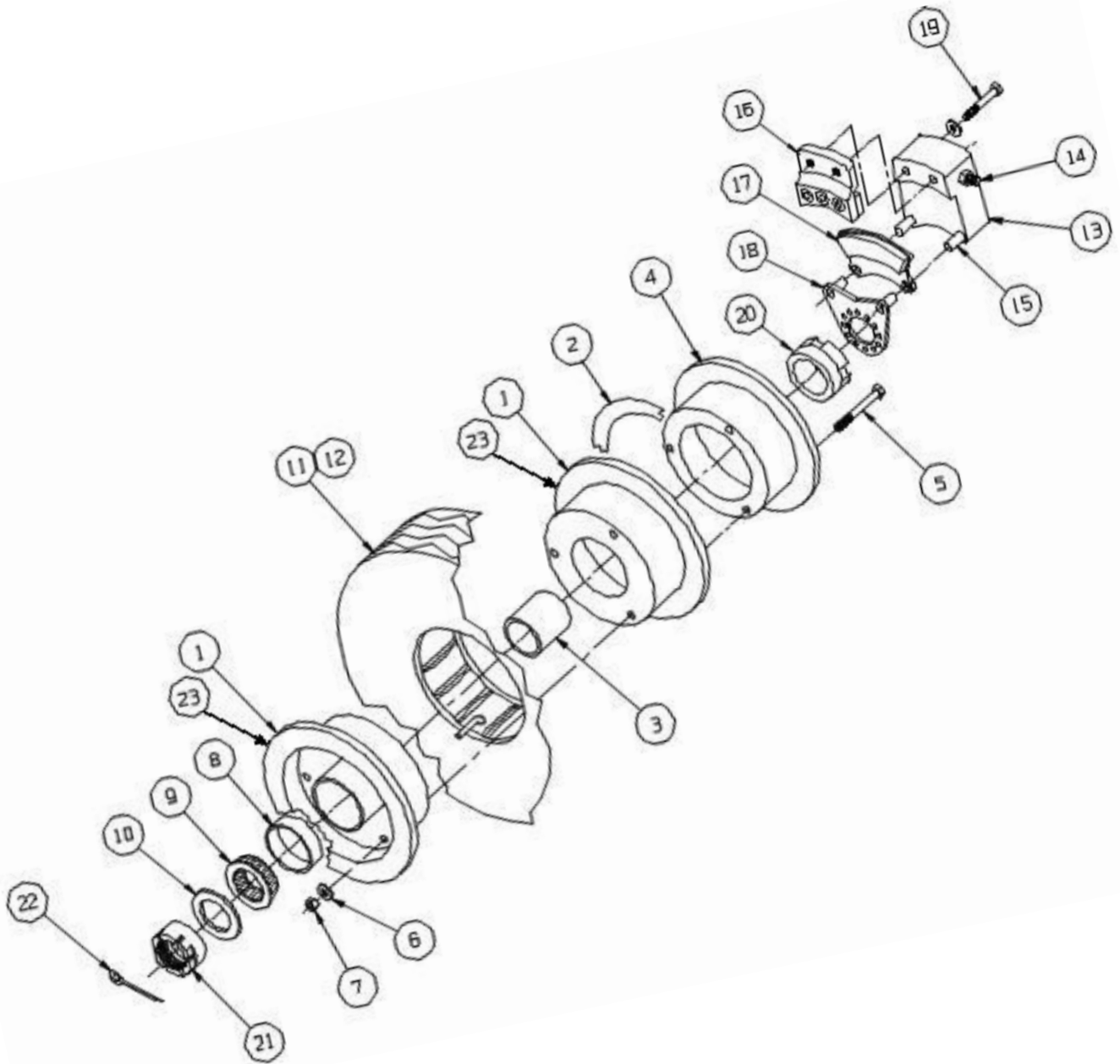

PARTS MANUAL
2100 FLOATS ON CESSNA 170

ITEM	QTY	PART NO.	PART DESCRIPTION
1	1	3A04000-002	ASSY. – WHEEL (W/ TUBE & TIRE)
	1	3A04000-060	ASSY. - WHEEL
2	1	3A04620-001	GASKET - TEFLON
3	1	3A04616-001	GREASE RETAINER
4	1	164-01700	BRAKE DISC
5	3	AN4-22A	BOLT, 1/4-28, 1.8125 GRIP, UNDRILLED, STEEL
6	3	NAS1149F0432P	WASHER, 0.265 ID, 0.032 THK, STEEL
7	3	MS21044N4	NUT, LOCKING, REGULAR HEIGHT, 1/4-28 UNF
8	2	8231	BEARING CUP
	2	8231CP	BEARING CUP, CHROME (OPT.)
9	2	8125	BEARING CONE
	2	8125CP	BEARING CONE, CHROME (OPT.)
10	2	473237	SEAL - INSIDE/OUTSIDE
11	1	AA1D4*	TIRE –TYPE III
12	1	XA1AC*	TUBE
	1	075-00800	ASSY. – BRAKE AND TORQUE PLATE
13	1	21A04000-096	ASSY. – CALIPER (RIGHT)
	1	21A04000-097	ASSY. – CALIPER (LEFT)
	1	062-00300	PISTON
	1	AN6227-23	“O” RING
	1	MS20823-3D	FITTING - 45 DEGREES (BRAKE LINE)
14	1	081-30619	SEAT – BLEEDER
	1	79-3	SCREW – BLEEDER
	1	183-1	CAP – BLEEDER
15	2	069-00400	ANCHOR BOLT
	2	NAS1149F0463P	WASHER, 0.265 ID, 0.063 THK, STEEL
	2	MS21044N4	NUT, LOCKING, REGULAR HEIGHT, 1/4-28 UNF
16	1	074-02700	ASSY. – BACK PLATE
	1	064-00500	PLATE – BACK
	1	066-10600	LINING
	3	105-00200	RIVET
17	1	073-04800	ASSY. – PRESSURE PLATE
	1	063-00500	PLATE - PRESSURE
	1	066-10600	LINING
	3	105-00200	RIVET
18	1	3A04711-001	BRAKE TORQUE PLATE - LEFT
	1	3A04711-002	BRAKE TORQUE PLATE – RIGHT
19	1	AN4H15A	BOLT, 1/4-28 THREAD, 1-3/16" GRIP, 1-21/32" LENGTH
	1	NAS1149F0432P	WASHER, 0.265 ID, 0.032 THK, STEEL
20	1	3A04093-001	SPACER
21	1	3A04268-003	NUT – AXLE

ITEM	QTY	PART NO.	PART DESCRIPTION
22	1	MS24665-351	COTTER PIN
23	1	40-78A	WHEEL ASSEMBLY, EXTERNAL, 5.00 X 5

* Any alternate tire (tube type) which is TSO-approved, matches the listed tire's dimensions, and meets its speed/load/ply ratings may be used. Equivalent tubes may also be used.

SECTION 9
STRUTS, STEPS, STEERING / RETRACT, WIRES AND
SPREADER BARS

CONTENTS

STRUTS, STEPS, STEERING / RETRACT, WIRES AND SPREADER BARS86

STRUTS, STEPS, STEERING / RETRACT, WIRES AND SPREADER BARS

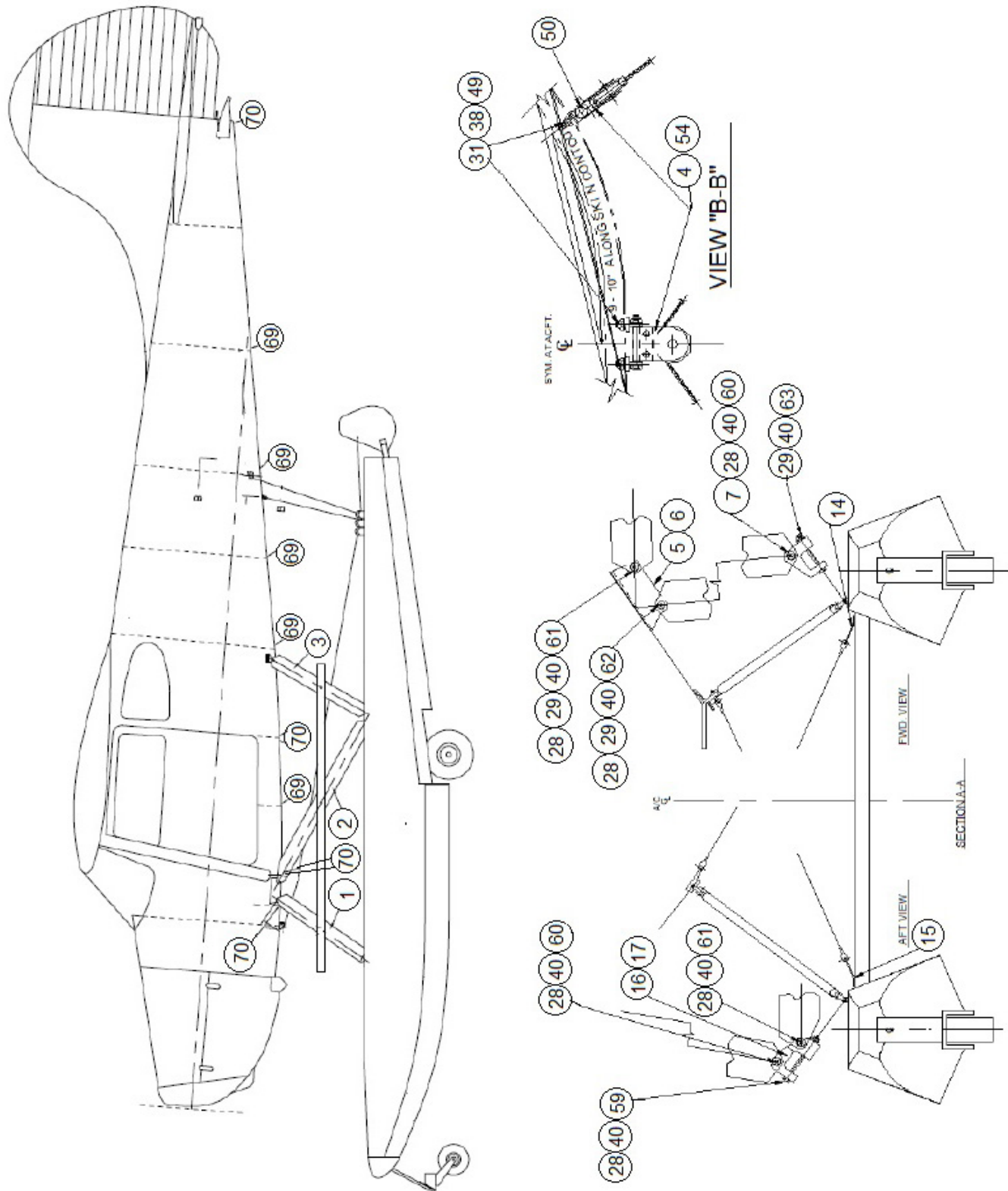

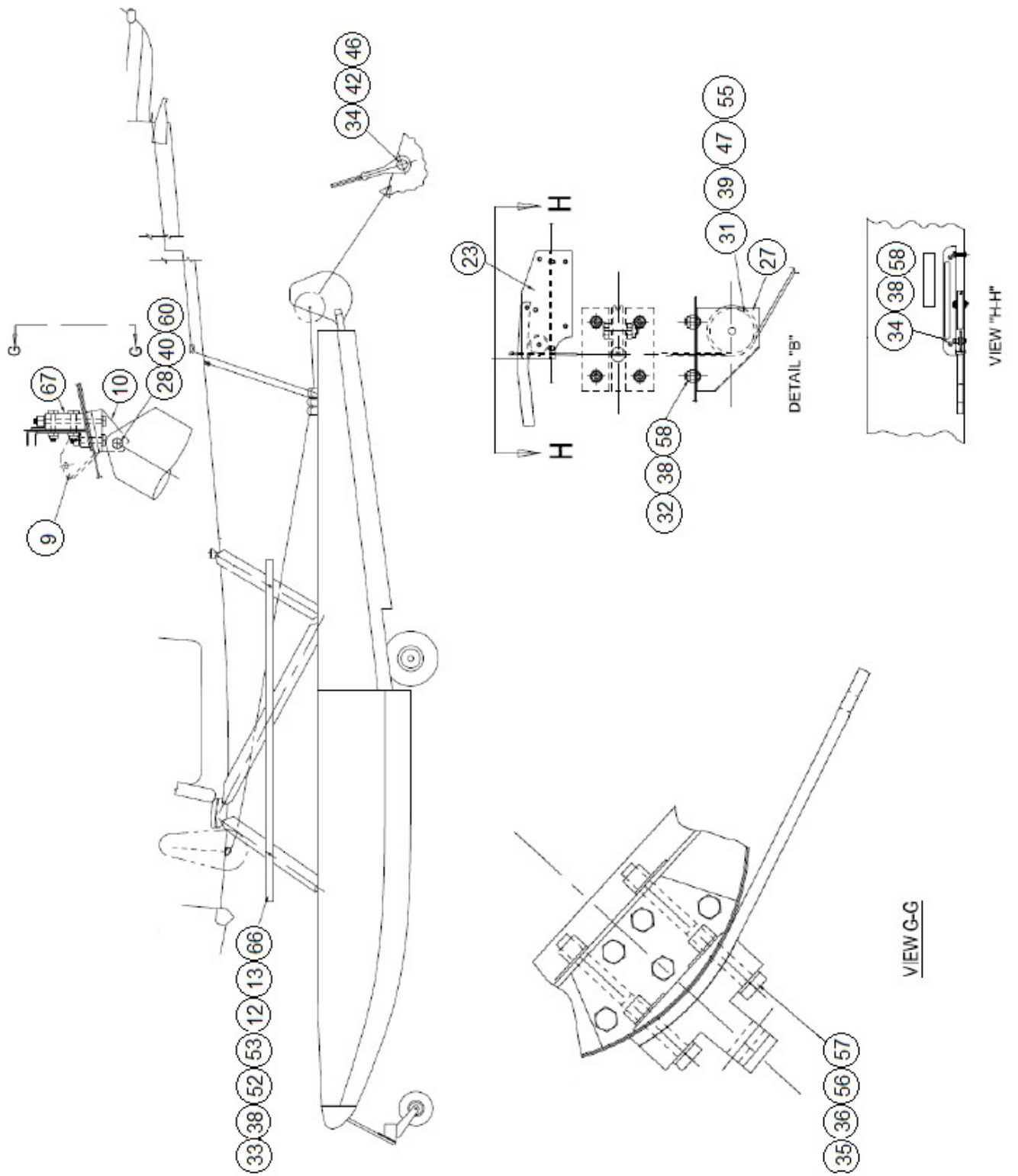

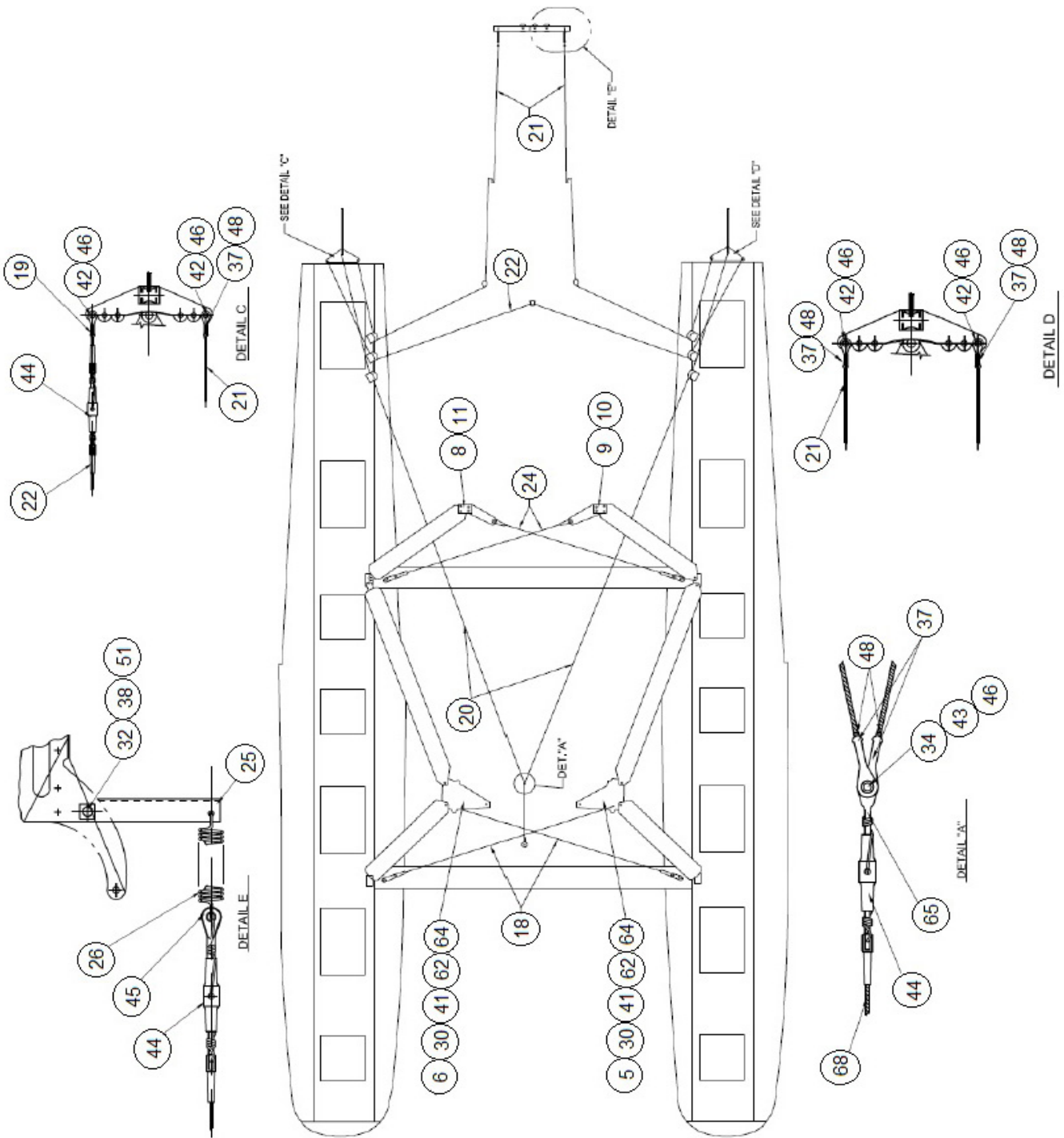

PARTS MANUAL
2100 FLOATS ON CESSNA 170

ITEM	QTY	PART NO.	PART DESCRIPTION
1	2	21A02000-180	ASSEMBLY, STRUT, FWD, 170
2	2	21A02000-181	ASSEMBLY, STRUT, MID, 170
3	2	21A02000-182	ASSEMBLY, STRUT, REAR, 170
4	3	21A08000-125	PULLEY ASS'Y
5	2	21A02021-005	FITTING, FWD. FUS. STRUT ATTACH
6	1	21A02021-006	FITTING, FWD. FUS. STRUT ATTACH
7	2	21A02060-012	FITTING, FWD. LOWER - FLOAT
8	1	21A02020-004	WIRE PULL FUSELAGE AFT
9	1	21A02020-005	WIRE PULL FUSELAGE AFT
10	1	21A02030-007	FITTING - AFT FUSELAGE
11	1	21A02030-008	FITTING - FUSELAGE
12	1	21A02369-033	STEP, LEFT
13	1	21A02369-054	STEP, RIGHT
14	2	21A02462-004	WIRE PULL, FWD
15	2	21A02519-007	WIRE PULL, AFT
16	1	21A02060-010	FITTING, AFT - LOWER - FLOAT
17	1	21A02060-011	FITTING, AFT - LOWER - FLOAT
18	2	21A02000-149	ASS'Y DRAG WIRE
19	1	21A08000-132	ASS'Y CABLE BALANCE
20	2	21A08000-133	ASS'Y RETRACT CABLE
21	2	21A08000-135	ASS'Y STEERING CABLE
22	1	21A08000-136	ASS'Y BALANCE CABLE
23	1	21A08000-149	ASS'Y RETRACT HANDLE
24	2	21A02000-164	ASS'Y DRAG WIRE
25	1	21A08359-201	RUDDER HORN EXTENSION
26	1	21A08525-005	RUDDER CENTERING SPRING
27	1	3A08151-046	PULLEY BRACKET, WATER RUDDER
28	11	NAS1149D0663J	WASHER, 0.39 ID, 0.063 THK, ALUMINUM
29	4	NAS1149D0616J	WASHER, 0.39 ID, 0.016 THK, ALUMINUM
30	4	NAS1149F0763P	WASHER, 0.453 ID, 0.063 THK, STEEL
31	7	NAS1149D0463J	WASHER, 0.265 ID, 0.063 THK, ALUMINUM
32	12	NAS1149D0363J	WASHER, 0.203 ID, 0.063 THK, ALUMINUM
33	8	NAS1149F0363P	WASHER, 0.203 ID, 0.063 THK, STEEL
34	7	NAS1149F0332P	WASHER, 0.203 ID, 0.032 THK, STEEL
35	8	NAS1149F0563P	WASHER, 0.328 ID, 0.063 THK, STEEL
36	8	NAS1025-054	NUT PLATE
37	4	NAS1435K3	FORK END TERMINAL
38	22	MS21044N3	NUT, LOCKING, REGULAR HEIGHT, 10-32 UNF
39	1	MS21044N4	NUT, LOCKING, REGULAR HEIGHT, 1/4-28 UNF
40	13	MS21044N6	NUT, NYLON INSERT, 250 DEG, STEEL, 0.375-24 THREAD
41	4	MS20365-720A	NUT, SELFLOCKING, 7/16-20 THREAD, NYLON INSERT, 250 DEG

ITEM	QTY	PART NO.	PART DESCRIPTION
42	6	MS20392-2C13	CLEVIS PIN
43	1	MS20392-2C15	CLEVIS PIN
44	3	MS21251-B3S	TURNBUCKLE BARREL
45	1	MS21255-3RS	TURNBUCKLE BARREL
46	6	MS24665-151	COTTER PIN
47	1	MS20219-2	PULLEY
48	4	MS20664C-3	BALL
49	6	AN42-4A	EYE BOLT
50	3	AN3-17A	BOLT, 10-32, 1.5 GRIP, UNDRILLED, STEEL
51	2	AN3-14A	BOLT, 10-32 THREAD, 1-1/8" GRIP, 1-17/32" LENGTH
52	2	AN3-20A	BOLT, 10-32, 1.625 GRIP, UNDRILLED, STEEL
53	4	AN3-25A	BOLT, 10-32 THREAD, 2-1/4" GRIP, 2-21/32" LENGTH
54	3	AN393-49	CLEVIS PIN
55	1	AN4-7A	BOLT, 1/4-28, 0.4375 GRIP, UNDRILLED, STEEL
56	4	AN5-13A	BOLT, 5/16-24 THREAD, 15/16" GRIP, 1-15/32" LENGTH
57	4	AN5-32A	BOLT, 5/16-24 THREAD, 2-13/16" GRIP, 3-11/32" LENGTH
58	8	AN526-1032R8	SCREW, TRUSS HEAD, NON STRUCTURAL, CAD 1, STEEL
59	2	AN6-40A	BOLT, 3/8-24 THREAD, 3-7/16" GRIP, 4-5/64" LENGTH
60	5	AN6-17A	BOLT, 3/8-24, 1.3125 GRIP, UNDRILLED, STEEL
61	3	AN6-16A	BOLT, 3/8-24, 1.1875 GRIP, UNDRILLED, STEEL
62	3	AN46-16A	BOLT EYE, 3/8-24 THRD, 3/8" SIZE, 1-3/16" GRIP, 1-27/32" LNGTH
63	2	AN6-32A	BOLT, 3/8-24 THREAD, 2-11/16" GRIP, 3-21/64 LENGTH
64	2	AN7-20A	BOLT, 7/16-20 THREAD, 1-7/16" GRIP, 2-3/32" LENGTH
65	1	AN161-16RS	FORK TURNBUCKLE
66	1	8A08260-001	BUSHING
67	1	52-3-849	CESSNA KIT
68	1	21A08000-137	CABLE TO RETRACT HANDLE
69	A/R	0420342	DRAIN GROMMET (CESSNA)
70	A/R	0422342	DRAIN GROMMET (CESSNA)

SECTION 10

HYDRAULIC SYSTEM

CONTENTS

HYDRAULIC SYSTEM INSTALLATION POST SERVICE LETTER 233.....	92
HYDRAULIC SYSTEM INSTALLATION PRE SERVICE LETTER 233	94
HYDRAULIC PUMP ASSEMBLY 1011887 POST SERVICE LETTER 233	96
HYDRAULIC PUMP ASSEMBLY 21A09000-279 PRE SERVICE LETTER 233.....	100
HYDRAULIC BRACKET ASSEMBLY 1006819 PRE SERVICE LETTER 233	102
HYDRAULIC PUMP ASSEMBLY 1009550 PRE SERVICE LETTER 233	104
HYDRAULIC PUMP OVERVIEW POST SERVICE LETTER 233.....	106
HYDRAULIC PUMP OVERVIEW PRE SERVICE LETTER 233	108
HYDRAULIC & BRAKE SCHEMATIC.....	110

HYDRAULIC SYSTEM INSTALLATION POST SERVICE LETTER 233

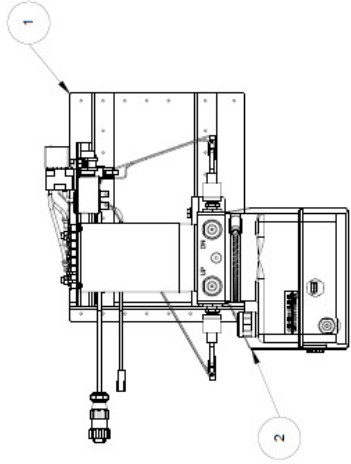

SECTION B-B
HYDRAULIC PUMP INSTALL
AFT FUSELAGE, LEFT SIDE

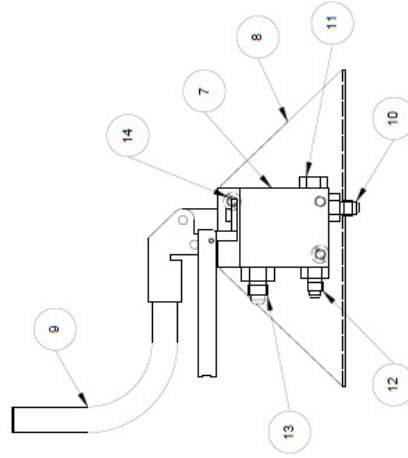

SECTION C-C
HAND PUMP INST.

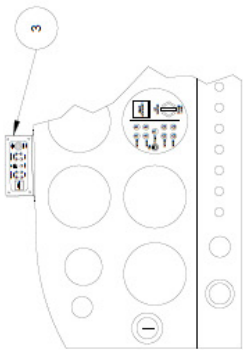
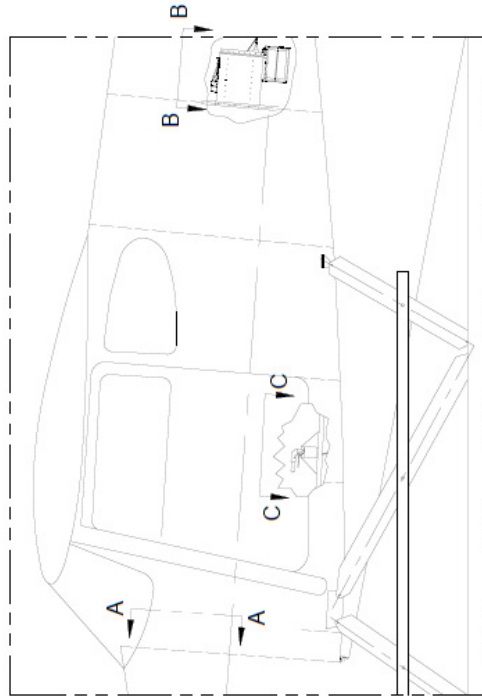

SECTION A-A
INSTR. PANEL VIEW (GEAR CONTROL)

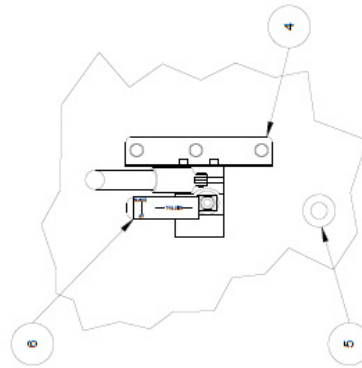

SECTION C-C
(HAND PUMP INST.)

PARTS MANUAL
2100 FLOATS ON CESSNA 170

ITEM	QTY	PART NO.	PART DESCRIPTION
1	1	1011883	ASSEMBLY, INSTALLATION BRACKET
2	1	1011887	ASSEMBLY, HYDRAULIC POWER PACK, 12V
	2	AN3-5A	BOLT, 10-32, 0.25 GRIP, UNDRILLED, STEEL
	2	NAS1149F0363P	WASHER, 0.203 ID, 0.063 THK, STEEL
	3	AN4-5A	BOLT, 1/4-28, 0.19 GRIP, UNDRILLED, STEEL
	3	NAS1149F0463P	WASHER, 0.265 ID, 0.063 THK, STEEL
3	1	21A11158-194	COVER, SQUARE, GEAR CONTROL
	4	MS35214-42	(GEAR CONTROL HEAD SCREWS) SCREW, 8-32, 0.50 LENGTH
4	1	21A09000-194	ASSEMBLY, HAND PUMP
	3	AN3-7A	BOLT, 10-32 , 0.50 GRIP, UNDRILLED, STEEL
	3	NAS1149F0363P	WASHER, 0.203 ID, 0.063 THK, STEEL
	3	AN970-3	WASHER, 0.203 ID, 0.875 OD, 0.063 THK
	3	MS21044N3	NUT, LOCKING, REGULAR HEIGHT, 10-32 THREAD
5	1	MS35489-49	GROMMET, RUBBER, .75 HOLE, .125 PANEL
6	1	12A3-7379-1	PLACARD, EMERGENCY HAND PUMP
7	1	642873	HAND PUMP (ONLY)
8	1	21A09156-129	BRACKET, HYDRAULIC HAND PUMP
9	1	21A09396-001	HANDLE
	1	9283K13	CAP PLUG
10	1	21A09746-001	MODIFIED UNION
	1	MS28775-012	O-RING, HYDRAULIC PACKING, 0.364 ID
11	1	AN814-4D	PLUG, 7/16-20 THREAD
	1	MS28775-012	O-RING, HYDRAULIC PACKING, 0.364 ID
12	1	AN815-4D	UNION
	1	MS28775-012	O-RING, HYDRAULIC PACKING, 0.364 ID
13	1	AN919-6D	UNION
	1	MS28775-014	O-RING, HYDRAULIC PACKING, 0.489 ID
14	2	MS16997-77	SOCKET HEAD CAP SCREW, 5/16-18 THREAD
	2	MS35333-41	LOCK WASHER, INTERNAL TOOTH
	2	NAS1149F0563P	WASHER, 0.328 ID, 0.063 THK, STEEL
15	2	21A04000-080	ASSEMBLY, BRAKE LINE (NOT SHOWN)

HYDRAULIC SYSTEM INSTALLATION PRE SERVICE LETTER 233

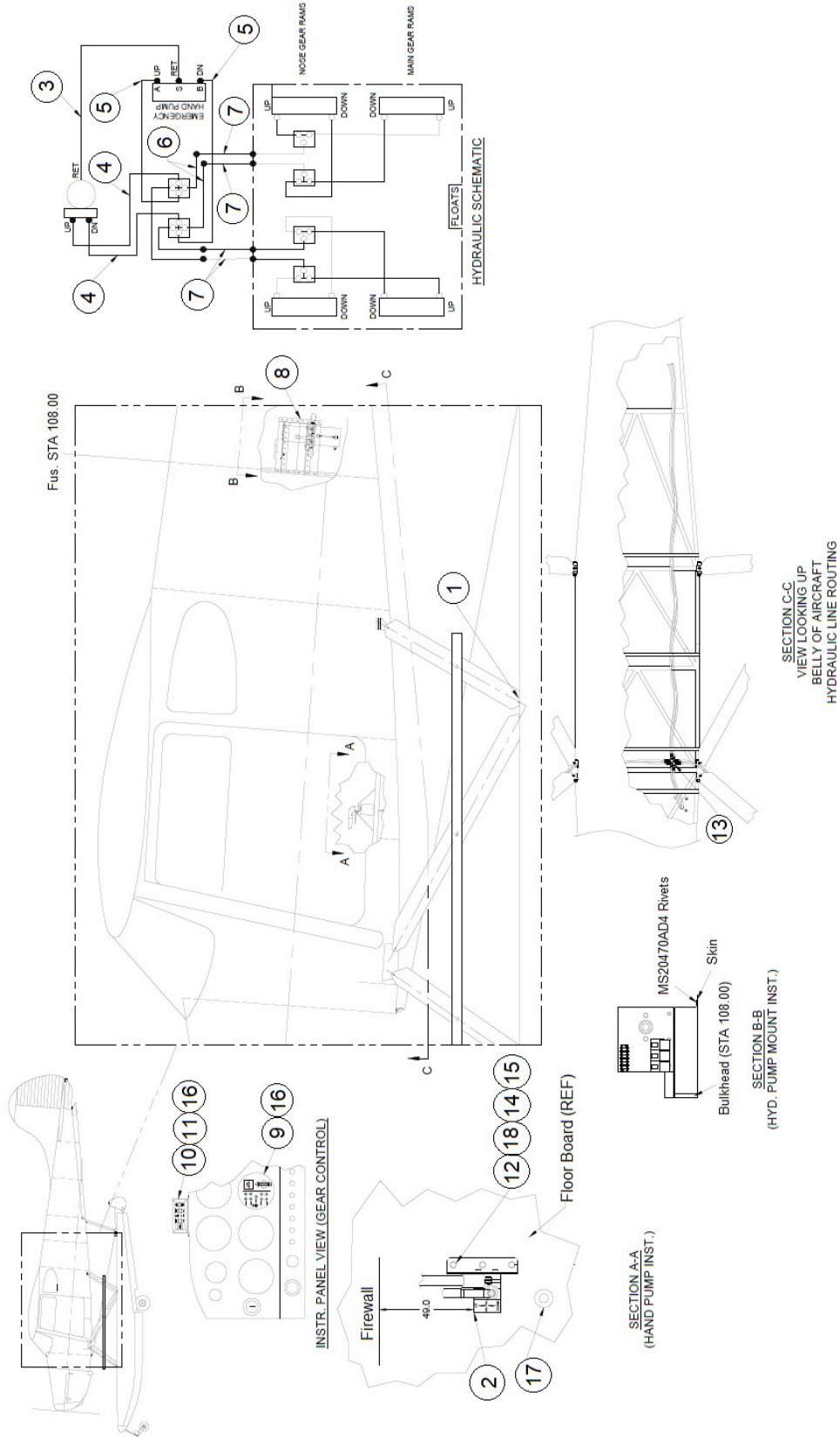

PARTS MANUAL
2100 FLOATS ON CESSNA 170

ITEM	QTY	PART NO.	PART DESCRIPTION
-	1	21A09000-279	ASSY. - HYD PUMP 12V, C-170
1	2	21A04000-080	HYD. LINE ASSY. BRAKE LINE FLOAT TO PLANE
2	1	21A09000-194	ASS'Y HAND PUMP & BRACKET
3	1	21A09000-226	ASSEMBLY, HOSE, RET. HAND PUMP TO PUMP
4	2	21A09000-227	HYD. LINE ASSEMBLY, PUMP TO TEE (170)
5	2	21A09000-228	HYD. LINE ASSEMBLY, HAND PUMP TO TEE (170)
6	2	21A09000-229	HYD. LINE ASSEMBLY, TEE TO WRAP (170)
7	4	21A09000-230	HYD. LINE ASSEMBLY, FUSELAGE TO FWD DECK (170)
8	1	21A09000-279	ASSEMBLY, HYDRAULIC PUMP, C-170
9	1	21A11000-009	GEAR SELECTOR ASSY. ROUND 12V
10	1	21A11000-010	GEAR SELECTOR ASSY. SQUARE 12V
11	1	21A11158-194	COVER, GEAR CONTROL HEAD
12	3	AN3-7A	BOLT, 10-32, 0.5 GRIP, UNDRILLED, STEEL
13	2	AN827-4D	CROSS FITTING, FLARED TUBE
14	3	AN970-3	WASHER, .203 ID, .875 OD, .063 THK
15	3	MS21044N3	NUT, LOCKING, REGULAR HEIGHT, 10-32 UNF
16	4	MS35214-42	SCREW, PAN HEAD, 8-32 THREAD, 1/2" LENGTH
17	1	MS35489-49	GROMMET
18	3	NAS1149F0363P	WASHER, 0.203 ID, 0.063 THK, STEEL

HYDRAULIC PUMP ASSEMBLY 1011887 POST SERVICE LETTER 233

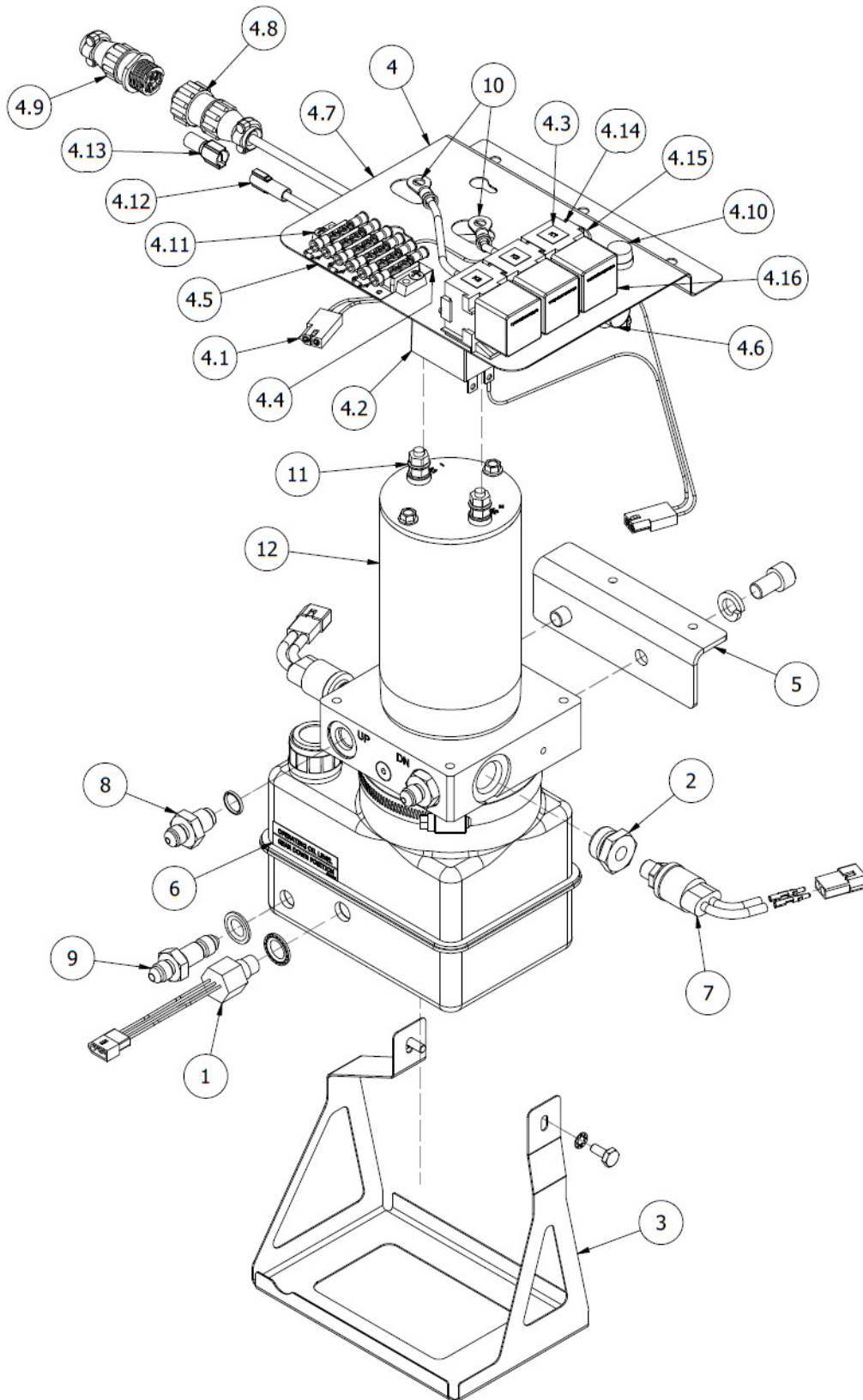

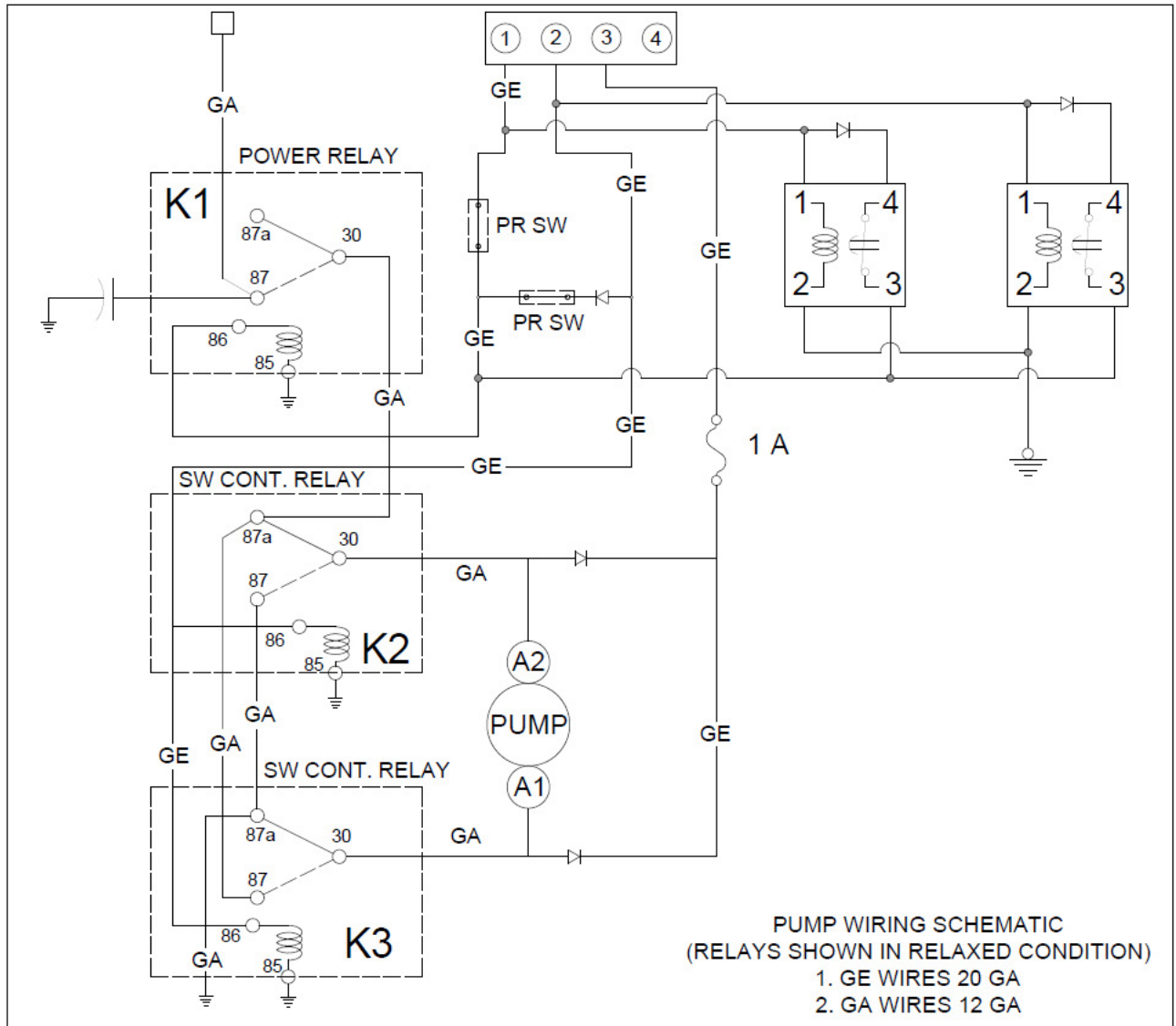

ITEM	QTY	PART NO.	PART DESCRIPTION
-	1	1011887	ASSEMBLY, HYDRAULIC POWER PACK, 12V
1	1	1009428	ASSEMBLY, SENSOR, FLUID LEVEL
	1	93786A200	PRESSURE SEALING WSHR, M12
	1	NJAM12X1.0CLZ	NUT, JAM, M12X1.0, ZINC
2	2	1011062	ASSEMBLY, PLUG, PRESSURE SWITCH PORT
3	1	1011542	SUPPORT, HYDRAULIC RESERVOIR, SIDE MOUNT
	2	AN3-3A	BOLT, 10-32, 0.0625 GRIP, UNDRILLED, STEEL
	2	MS35333-39	STAR WASHER
4	1	1011885	ASSEMBLY, SUPPORT PLATE, HYDRAULIC PUMP, 12V
4.1	2	03-09-1022	CONNECTOR PLUG, MALE, 2 CONN.
	4	02-09-1104	PIN, CRIMP FEMALE, 1/8" DIA.
4.2	1	1005042	TIMER RELAY HARNESS
4.3	1	1009143-01	PLACARD, K1 INDICATOR
	1	1009143-02	PLACARD, K2 INDICATOR
	1	1009143-03	PLACARD, K3 INDICATOR
4.4	1	1009144-01	PLACARD, CR INDICATOR
4.5	1	1009144-02	PLACARD, AC INDICATOR
4.6	1	1011798	ASSEMBLY, CAPACITOR
	1	MS21919WDG10	CLAMP, LOOP, CUSHIONED, 5/8" TUBE OD
	1	AN3-5A	BOLT, 10-32, 0.25 GRIP, UNDRILLED, STEEL
	1	NAS1149F0332P	WASHER, 0.203 ID, 0.032 THK, STEEL
	1	NAS1149F0363P	WASHER, 0.203 ID, 0.063 THK, STEEL
	1	MS21044N3	NUT, LOCKING, REGULAR HEIGHT, 10-32 UNF
4.7	1	1011884	TOP PLATE, HYDRAULIC PUMP
4.8	1	206429-1	PLUG, MALE, CPC SIZE 1, 4 PIN
	3	66103-4	PIN, CRIMP SOCKET, 24-20 AWG
	1	206062-3	CLAMP, CABLE, CPC SIZE 11
4.9	1	206430-2	PLUG, FEMALE, CPC SIZE 1, 4 PIN
	3	66105-4	CRIMP SOCKET, FEMALE
	1	206062-3	CLAMP, CABLE, CPC SIZE 11
4.10	1	3453LF2A	FUSE HOLDER
	1	AGC-1	FUSE, 250V, 1 AMP
4.11	1	6-140	TERMINAL BLOCK, 6 CONNECTOR
	2	AN526C632R8	SCREW, MACHINE TRUSS HEAD, 6-32 THREAD
	2	MS21044N06	NUT, LOCKING, REGULAR HEIGHT, 6-32 UNC
	12	MS25036-102	RING TERMINAL, #6 STUD, 16-22 AWG, RED
	3	1N4004	DIODE
4.12	1	73F-250-32-NL	CONNECTOR, FEMALE, 10-12 AWG, FULLY INSULATED
4.13	1	73M-250-32-NL	CONNECTOR, MALE, 10-12 AWG, FULLY INSULATED
4.14	3	BR05-FW	SOCKET, 5 PRONG, PLASTIC
	14	1-901-355-917	TERMINAL

PARTS MANUAL
2100 FLOATS ON CESSNA 170

ITEM	QTY	PART NO.	PART DESCRIPTION
	2	AN3-3A	BOLT, 10-32, 0.0625 GRIP, UNDRILLED, STEEL
	4	NAS1149F0332P	WASHER, 0.203 ID, 0.032 THK, STEEL
	2	MS21044N3	NUT, LOCKING, REGULAR HEIGHT, 10-32 UNC
4.15	1	MS35489-14	GROMMET, RUBBER
4.16	3	V23234- A0001-X032	RELAY, 5 PRONG, 12V
5	1	1011886	ANGLE, MOUNTING, HYDRAULIC PUMP
	2	MS16997-96	SOCKET HEAD CAP SCREW
	2	MS35338-46	WASHER, SPLIT
6	1	6A3-2199	PLACARD, OIL LEVEL
7	2	20PS001EB700 W500W	PRESSURE SWITCH
	2	03-09-2022	CONNECTOR, PLUG, FEMALE
	4	02-09-2118	PIN, CRIMP MALE, 1/8" DIA.
8	2	AN919-3D	FITTING, REDUCER
	2	MS28775-013	O-RING, HYDRALUIC
9	1	AN832-4D	UNION, BULKHEAD
	1	93783A032	SEALING WASHER
	1	AN924-4D	JAM NUT
10	2	MS25036-157	RING TERMINAL, 1/4 STUD, 10-12 AWG, YELLOW
11	2	NAS1149F0432P	WASHER, 0.265 ID, 0.032 THK, STEEL
12	1	YBZS- C0.63W1T100K/ UVZOT2	HYDRAULIC PUMP, 12 VDC

HYDRAULIC PUMP ASSEMBLY 21A09000-279

PRE SERVICE LETTER 233

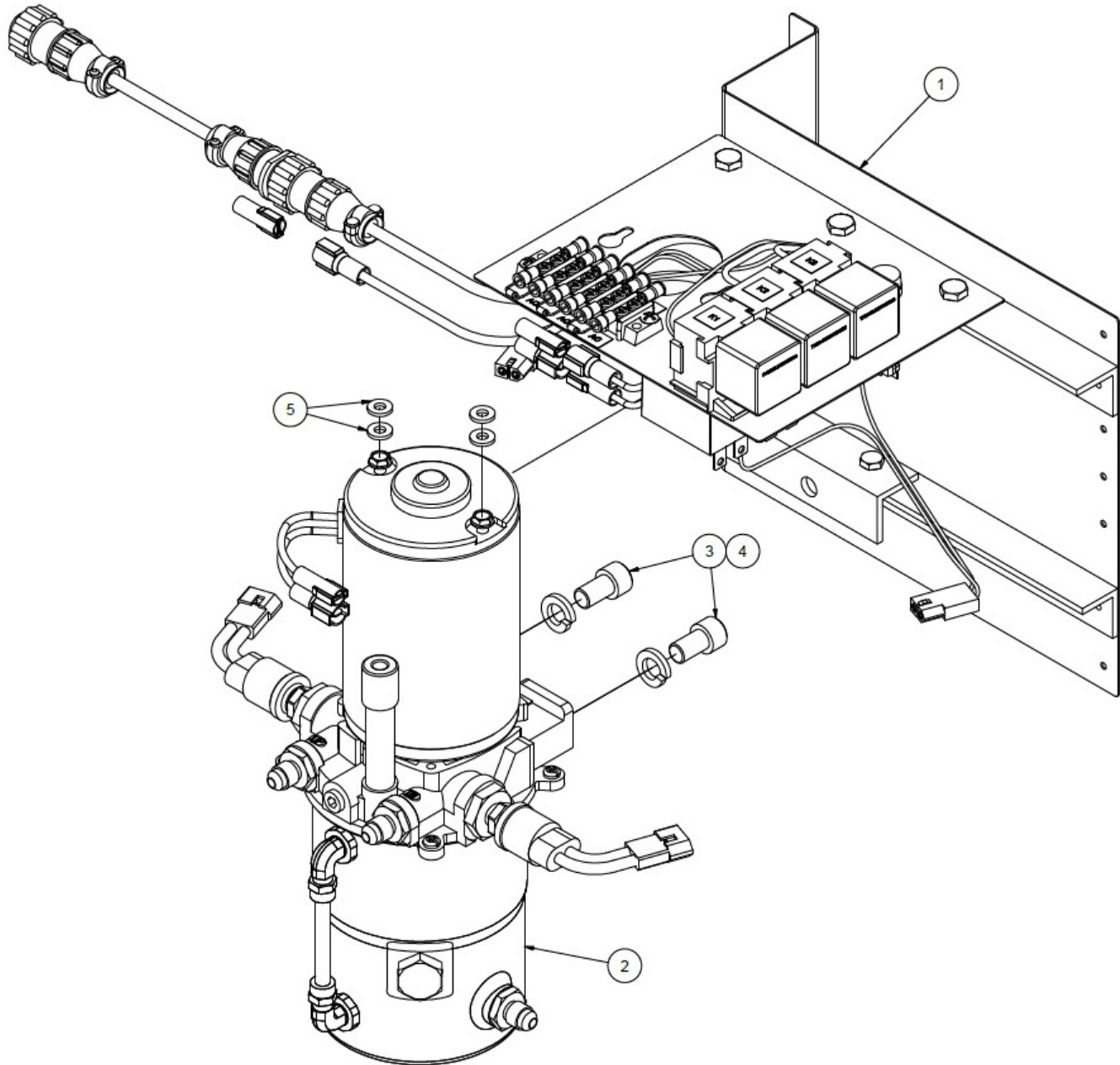

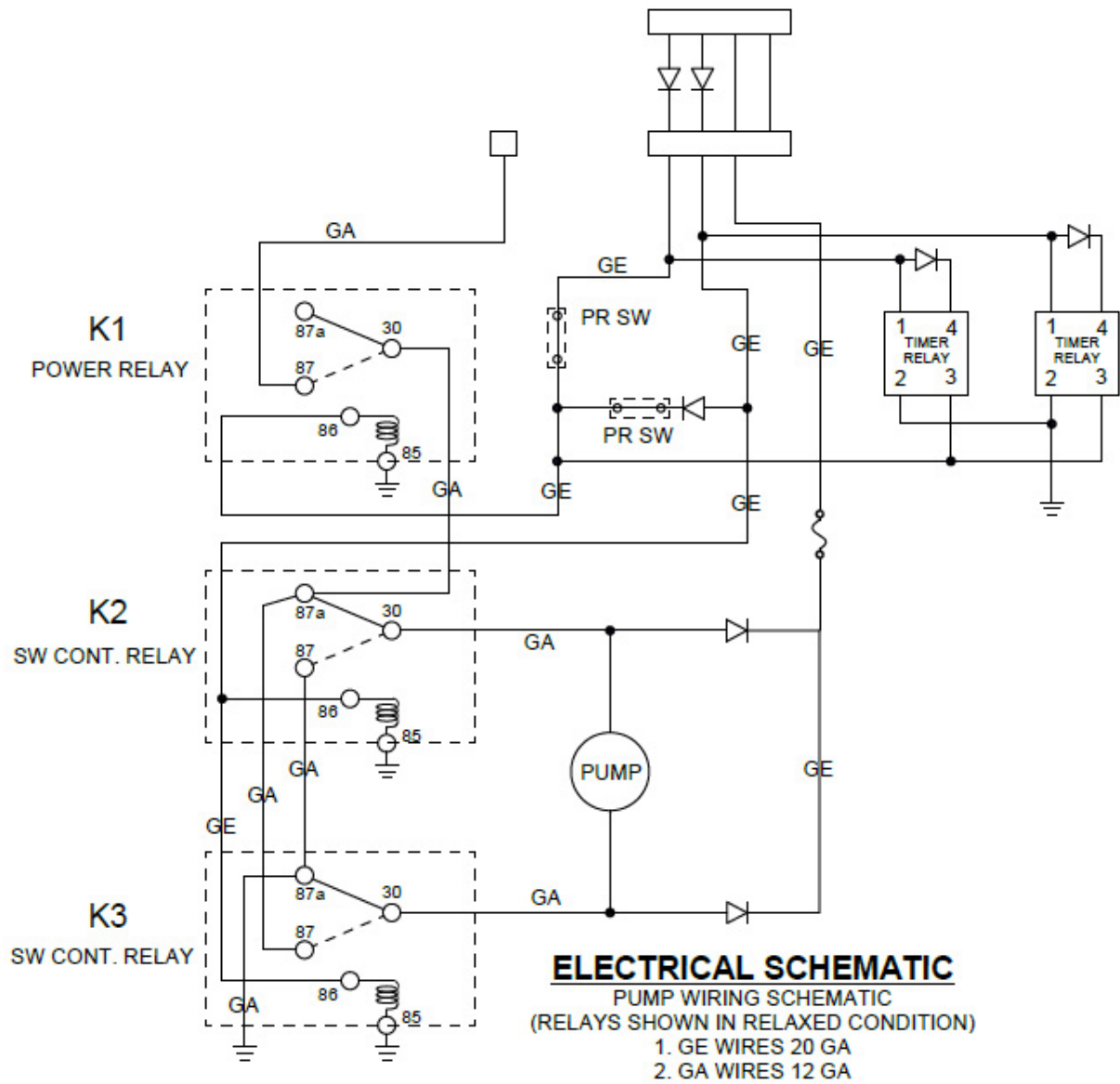

ITEM	QTY	PART NO.	PART DESCRIPTION
-	1	21A09000-279	ASSEMBLY, HYDRAULIC PUMP, C-170
1	1	1006819	ASSEMBLY, BRACKET, HYDRAULIC PUMP, 12V
2	1	1009550	ASSEMBLY, HYDRAULIC PUMP, HFLS 12V
3	2	MS16997-96	SOCKET HEAD CAP SCREW
4	2	MS35338-46	WASHER, SPLIT, CARBON STEEL
5	4	NAS1149F0363P	WASHER, 0.203 ID, 0.063 THK, STEEL

HYDRAULIC BRACKET ASSEMBLY 1006819 PRE SERVICE LETTER 233

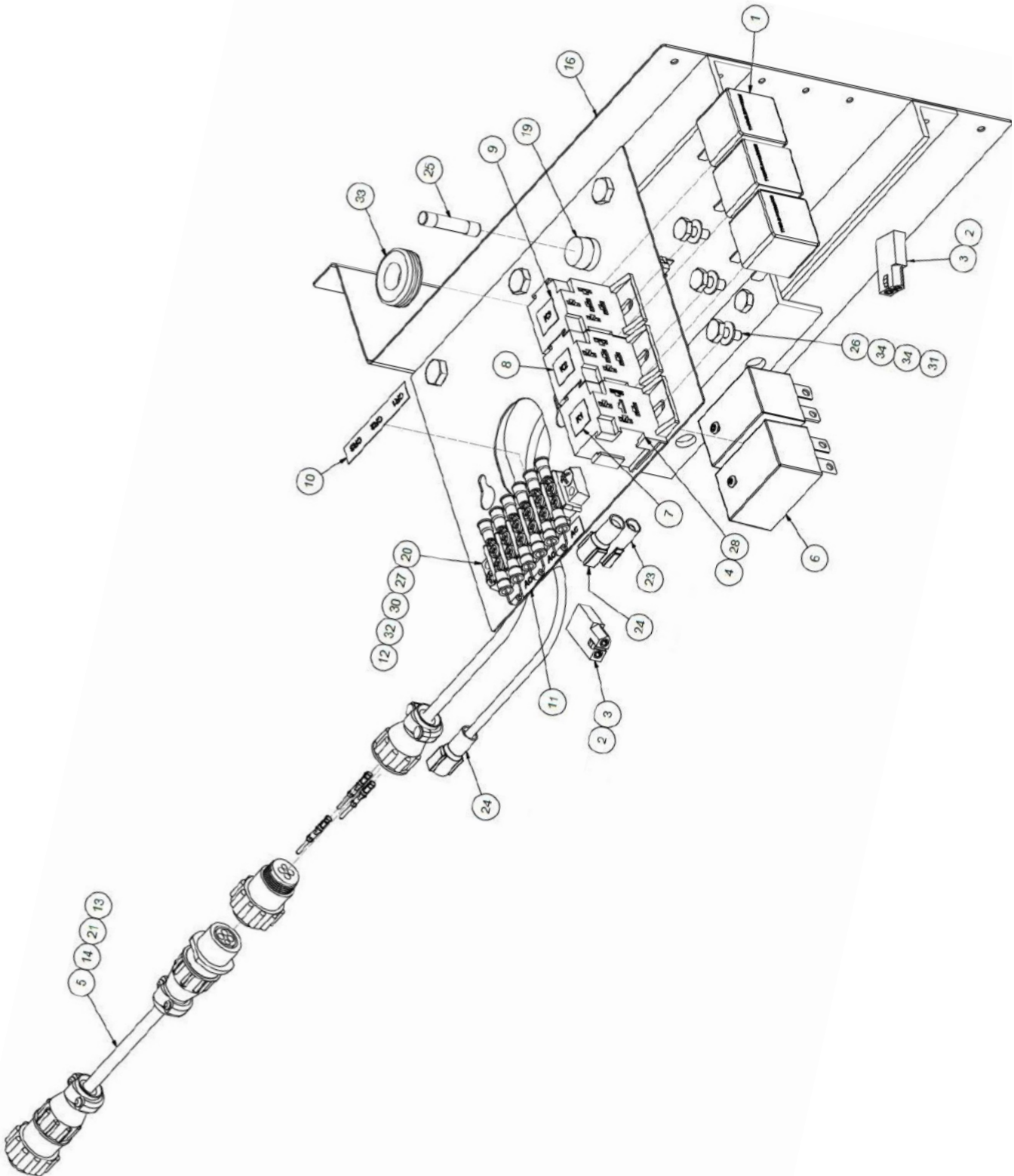

PARTS MANUAL
2100 FLOATS ON CESSNA 170

ITEM	QTY	PART NO.	PART DESCRIPTION
-	1	1006819	ASSEMBLY, BRACKET, HYDRAULIC PUMP, 12V
1	3	0-332-209-137	RELAY, 12V, 5 PRONG
2	4	02-09-1104	PIN, CRIMP FEMALE, 1/8" DIA
3	2	03-09-1022	CONNECTOR PLUG, MALE, 2 CONN.
4	14	1-901-355-917	TERMINAL
5	1	1004949	CABLE, DIODE ADAPTOR
6	1	1005042	TIMER RELAY HARNESS
7	1	1009143-01	PLACARD, K1 INDICATOR
8	1	1009143-02	PLACARD, K2 INDICATOR
9	1	1009143-03	PLACARD, K3 INDICATOR
10	1	1009144-01	PLACARD, CR INDICATOR
11	1	1009144-02	PLACARD, AC INDICATOR
12	3	1N4004	DIODE, 2-1/2"
13	2	206062-3	CLAMP, CABLE, CPC SIZE 11
14	1	206429-1	PLUG, MALE, CPC SIZE 1, 4 PIN
15	1	206430-2	CPC FREE HANG, 4 PIN, FEMALE
16	1	21A09000-278	ASS'Y, BRACKET - HYDRAULIC PUMP-170
17	6 FT	22759-16-12-9	WIRE, 12 AWG, WHITE
18	10.1 FT	22759-16-20-9	WIRE, 20 AWG, WHITE
19	1	3453LF2A	FUSE HOLDER
20	1	6-140	TERMINAL BLOCK, 6 CONNECTOR
21	3	66103-4	PIN, CRIMP SOCKET, 24-20G
22	3	66105-4	CRIMP SOCKET, FEMALE
23	3	73F-250-32-NL	CONNECTOR, FEMALE, 10-12 AWG
24	3	73M-250-32-NL	CONNECTOR, MALE, 10-12 AWG
25	1	AGC-1	FUSE, 250V, (S2565-1)
26	3	AN3-3A	BOLT, 10-32, 0.0625 GRIP, UNDRILLED, STEEL
27	2	AN526C632R8	SCREW, TRUSS HEAD MACHINE, 6-32 THREAD, 1/2" LENGTH
28	3	BR05-FW	SOCKET, 5 PRONG, PLASTIC
29	1.5 FT	HS105-3/16-0	HEAT SHRINK, TUBING, BLACK
30	2	MS21044N06	NUT, SELF LOCK, (250 DEG), NYLON INSERT, 6-32
31	3	MS21044N3	NUT, LOCKING, REGULAR HEIGHT, 10-32 UNF
32	12	MS25036-102	RING TERMINAL, #6 STUD, 16-22 AWG, RED
33	1	MS35489-14	GROMMET, RUBBER
34	6	NAS1149F0332P	WASHER, 0.203 ID, 0.032 THK, STEEL

HYDRAULIC PUMP ASSEMBLY 1009550 PRE SERVICE LETTER 233

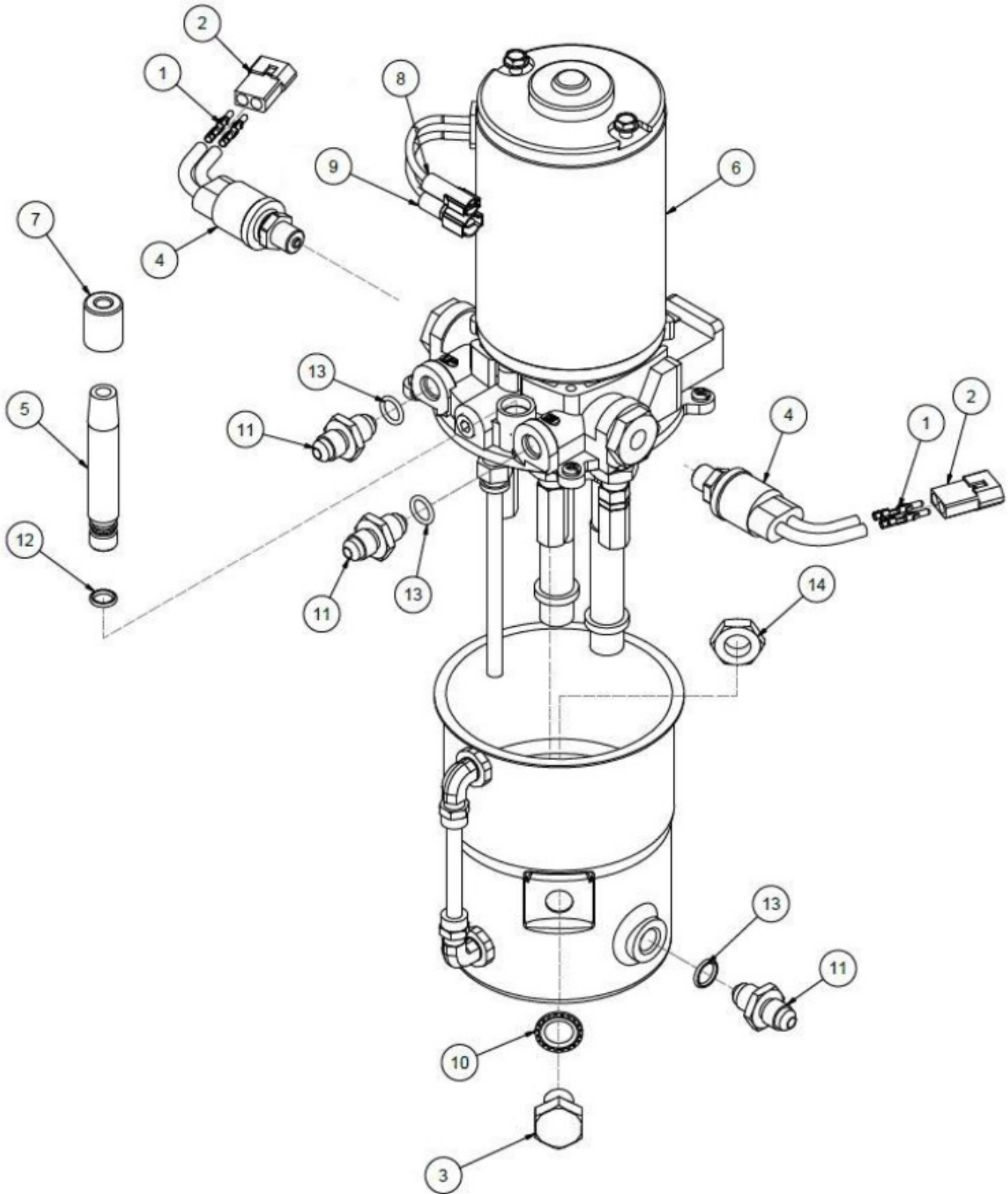

PARTS MANUAL
2100 FLOATS ON CESSNA 170

ITEM	QTY	PART NO.	PART DESCRIPTION
-	1	1009550	ASSEMBLY, HYDRAULIC PUMP, HFLS 12V
1	4	02-09-2118	PIN, CRIMP MALE, 1/8" DIA
2	2	03-092022	CONNECTOR PLUG, FEMALE
3	1	1009547	PLUG, HYDRAULIC RESERVOIR
4	2	20PS001EB700W5 00W	PRESSURE SWITCH
5	1	21A09274-006	STAND PIPE, HYDRAULIC PUMP
6	1	640661	HYDRAULIC PUMP (SEE DETAIL)
7	1	6A09706-001	FILTER, HYDRAULIC PIPE
8	2	73F-250-32-NL	CONNECTOR, FEMALE, 10-12 AWG
9	2	73M-250-32-NL	CONNECTOR, MALE, 10-12 AWG
10	1	93786A200	PRESSURE-SEALING WASHER, M12
11	3	AN815-4D	UNION
12	1	MS28775-011	O RING, DIA 0.301
13	3	MS28775-012	O RING, HYDRAULIC PACKING, .364 ID
14	1	NJAM12X1.0CLZ	NUT, JAM, M12X1.0, ZINC

HYDRAULIC PUMP OVERVIEW POST SERVICE LETTER 233

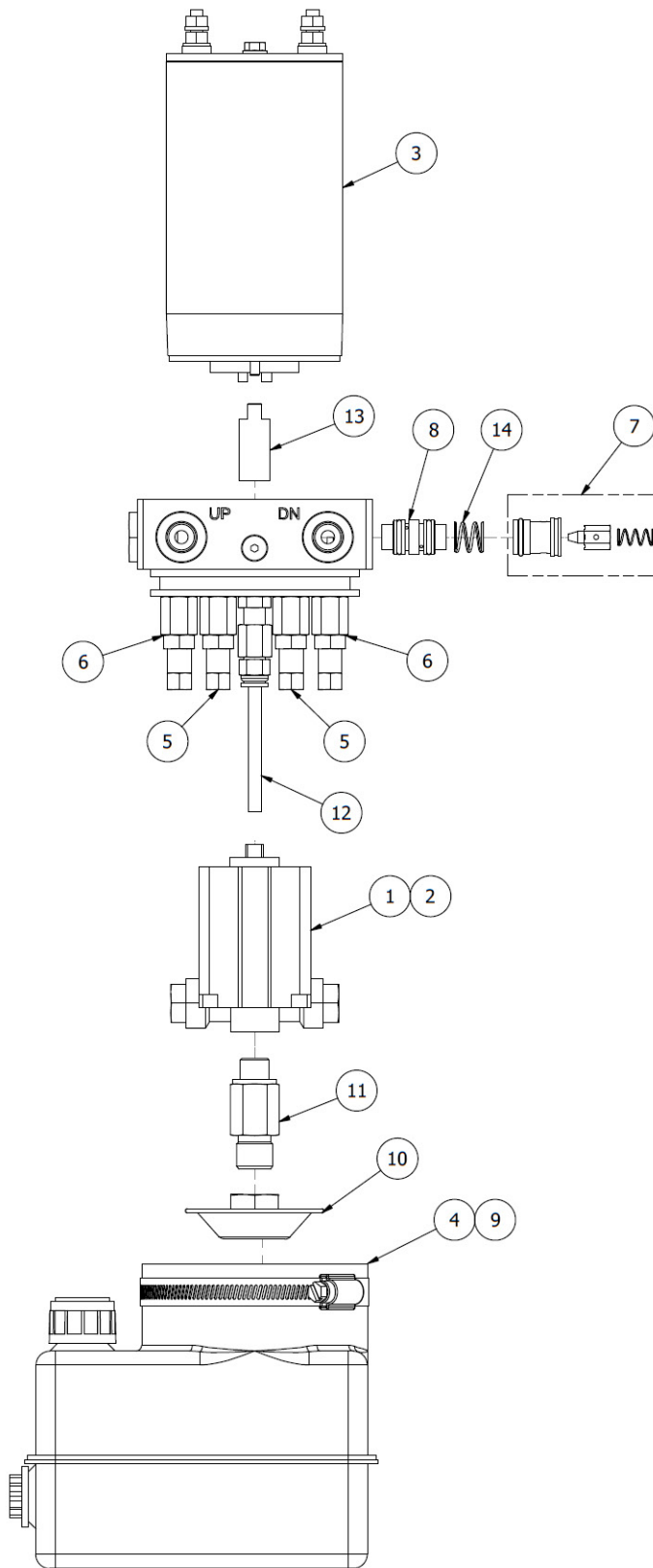

PARTS MANUAL
2100 FLOATS ON CESSNA 170

ITEM	QTY	PART NO.	PART DESCRIPTION
1	1	202-0003	BI-DIRECTIONAL PUMP, 0.64 ML/R
2	1	299-0008	SEAL KIT, BI-DIRECTIONAL GEAR PUMP
3	1	610-0010	DC MOTOR, 12V, .8KW
4	1	622-0016	RESERVOIR, 1 QT.
5	2	631-0005	PRESSURE RELIEF VALVE
6	2	631-0006	THERMAL RELIEF VALVE
7	2	632-0004	ASSEMBLY, PILOT OPERATED CHECK VALVE
8	1	637-0024	SHUTTLE VALVE
9	1	681-0050	CLAMP, HOSE, 1 LITER PLASTIC RESERVOIR
10	1	682-0019	FILTER, PICKUP TUBE, HYDRAULIC PUMP
11	1	682-0055	SUCTION HEX TUBE
12	1	682-0056	RETURN TUBE
13	1	683-0011	COUPLING, MOTOR TO PUMP
14	2	685-0012	SPRING, SHUTTLE VALVE
15	1	687-0001	SEAL KIT, RESERVIOR O-RING, PILOT OPERATED RELIEF VALVE O-RING, THERMAL AND PRESSURE RELIEF VALVE O-RING (NOT SHOWN)

HYDRAULIC PUMP OVERVIEW PRE SERVICE LETTER 233

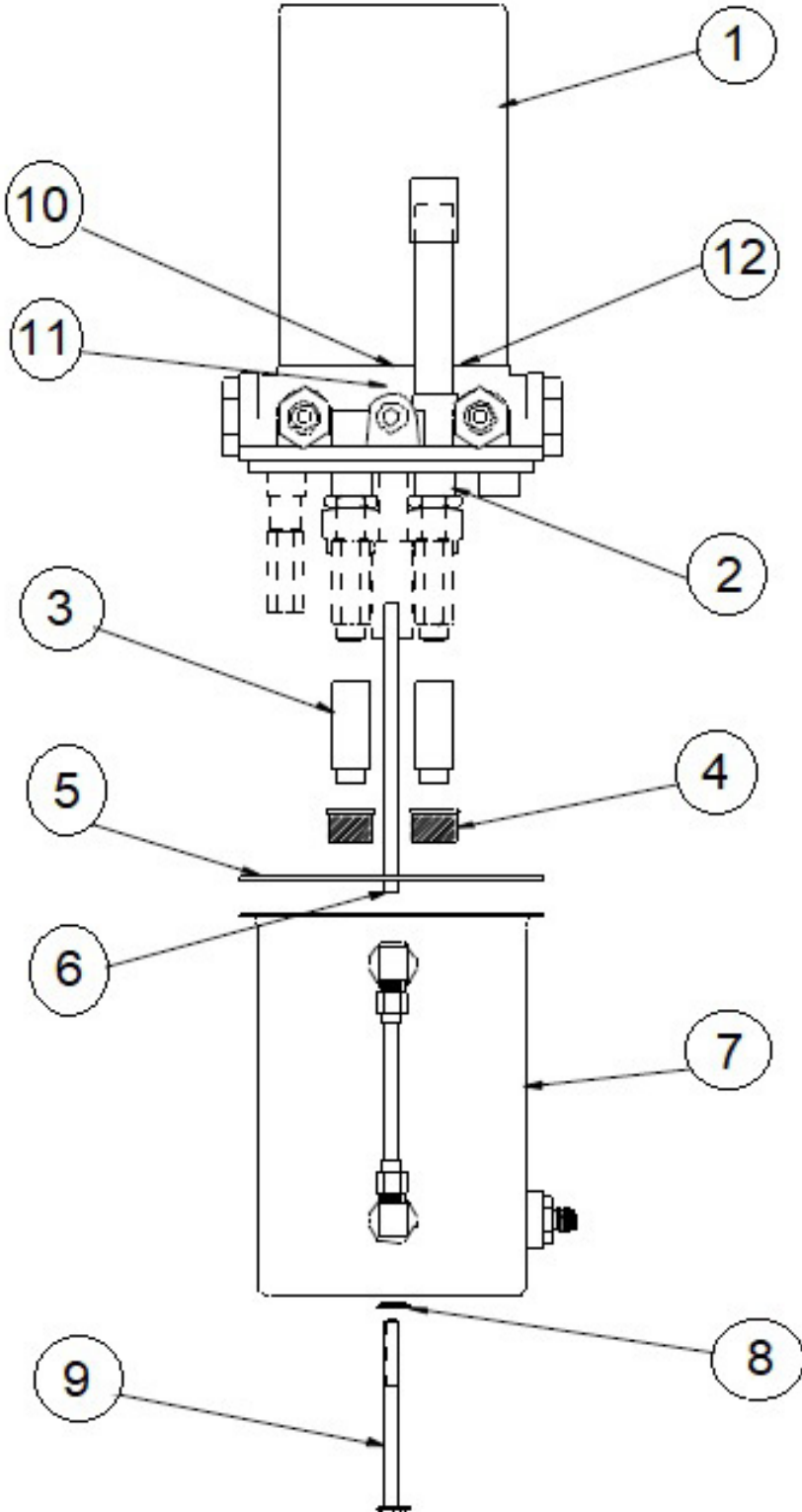

PARTS MANUAL
2100 FLOATS ON CESSNA 170

ITEM	QTY	PART NO.	PART DESCRIPTION
1	1	21A09000-215	HYDRAULIC PUMP ASSY. (12V)
	1	640661	MOTOR (12V)
2	1	634873	BASIC PUMP
3	2	362136	TUBE EXTENSIONS
4	2	410521*	FILTER
5	1	410578*	SEAL RESERVIOR
6	1	365047	RETURN TUBE
7	1	775260	RESERVIOR – GAUGE ASSY.
8	1	415067	SEAL THREAD
9	1	409715*	SCREW – RESERVIOR ATTACH
10	1	361183*	COUPLING – MOTOR TO PUMP
11	1	410512	SEAL – PUMP SHAFT
12	1	405673	O RING, 1-3/4" DIA

* Reference Wipaire drawing 1011065 for alternate part numbers.

HYDRAULIC & BRAKE SCHEMATIC

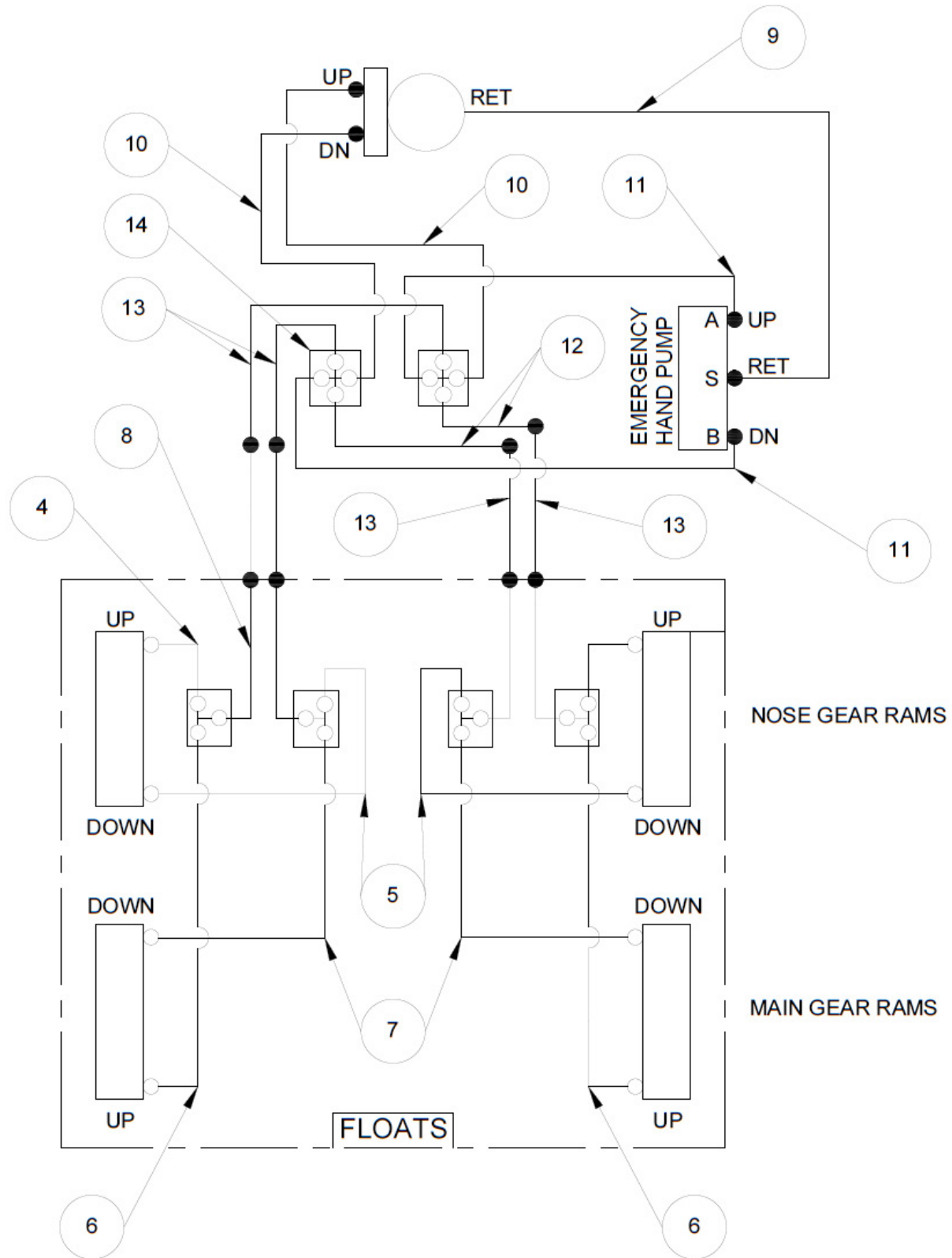

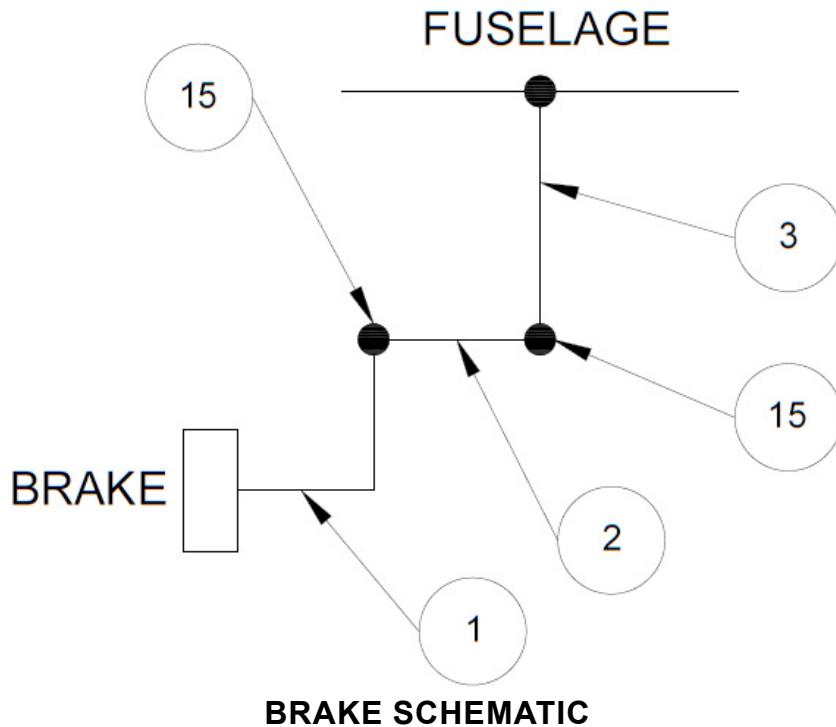

ITEM	QTY	PART NO.	PART DESCRIPTION
1	2	21A04000-078	ASSEMBLY, HOSE, BRAKE LINE, FLEX
2	2	21A04000-079	ASSEMBLY, HOSE, BRAKE LINE, HARD
3	2	21A09000-080	ASSEMBLY, HOSE, BRAKE LINE
4	2	21A09000-218	ASSEMBLY HOSE, NOSE UP TO TEE
5	2	21A09000-219	ASSEMBLY, HOSE, NOSE DOWN TO TEE
6	2	21A09000-220	ASSEMBLY, HOSE, MAIN UP TO TEE
7	2	21A09000-221	ASSEMBLY, HOSE, MAIN DOWN TO TEE
8	4	21A09000-222	ASSEMBLY, HOSE, TEE TO TOP DECK
9	1	21A09000-226	ASSEMBLY, HOSE, PUMP RESERVOIR TO HAND PUMP
10	2	21A09000-227	ASSEMBLY, HOSE, PUMP TO 4 WAY TEE
11	2	21A09000-228	ASSEMBLY, HOSE, HAND PUMP TO 4 WAY TEE
12	2	21A09000-229	ASSEMBLY, HOSE, RIGHT FLOAT TO 4 WAY TEE
13	4	21A09000-230	ASSEMBLY, HOSE, FUSELAGE TO FWD DECK FITTINGS
14	2	AN827-4D	CROSS FITTING, FLARED TUBE
15	2	AN833-3D	HYDRAULIC FITTING, 90° ELBOW
	2	NAS1149D0663J	WASHER, 0.39 ID, 0.063 THK, ALUMINUM
	2	AN924-3D	NUT, TUBE, 3/8-24 THREAD

THIS PAGE INTENTIONALLY LEFT BLANK

SECTION 11

ELECTRICAL

CONTENTS

ELECTRICAL SCHEMATIC POST SERVICE LETTER 233	114
ELECTRICAL SCHEMATIC PRE SERVICE LETTER 233.....	116
GEAR CONTROL (ROUND).....	118
GEAR CONTROL (RECTANGLE).....	121

ELECTRICAL SCHEMATIC POST SERVICE LETTER 233

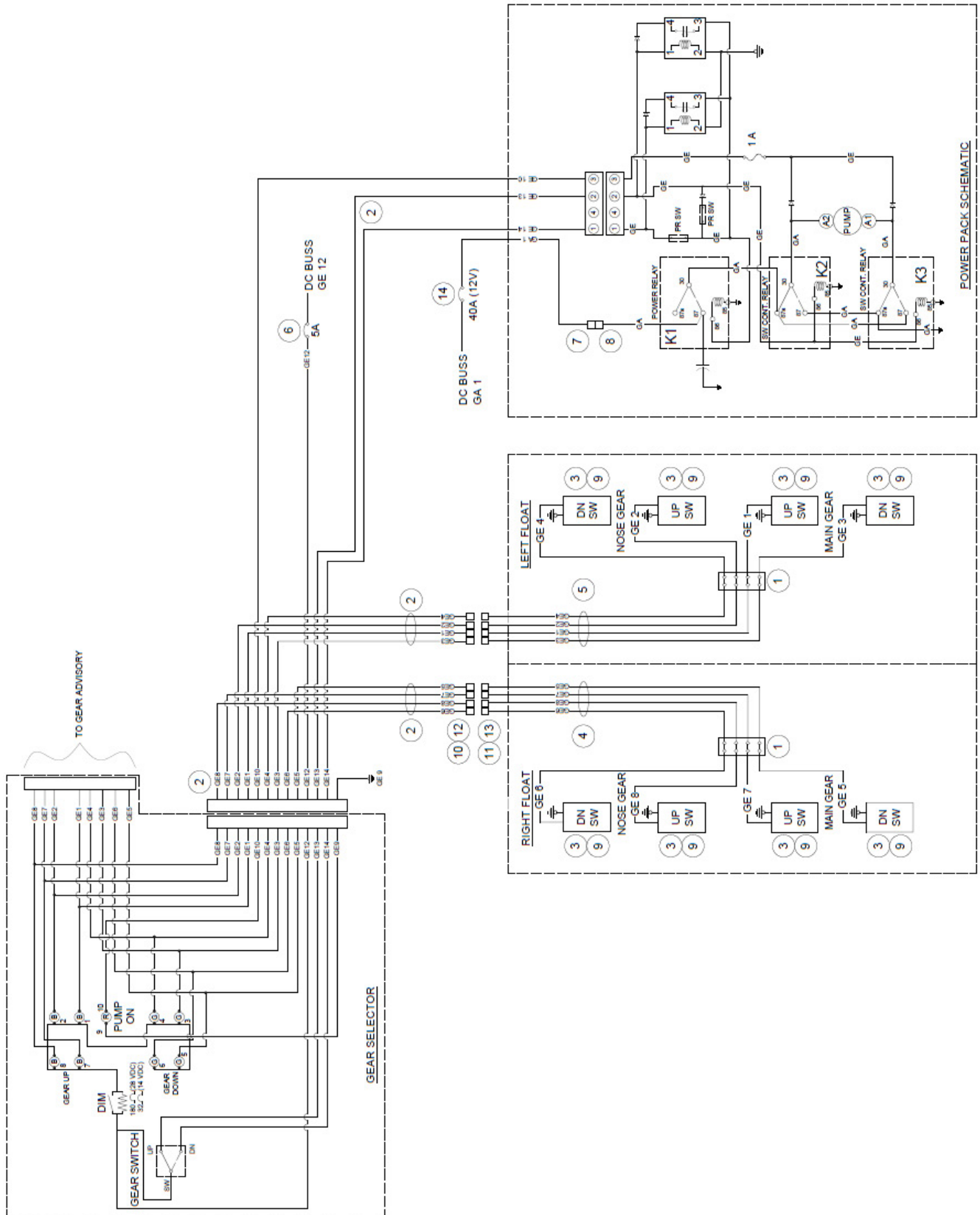

PARTS MANUAL
2100 FLOATS ON CESSNA 170

ITEM	QTY	PART NO.	PART DESCRIPTION
1	2	4-140	TERMINAL BLOCK, 4 POSITION
2	1	4A11000-011	WIRE HARNESS, GEAR SELECTOR, FLOATS, HYD. PUMP
3	8	5801	GEAR POSITION SWITCH, PROXIMITY, MAGNETIC
4	1	6A10000-004	WIRE HARNESS, LEFT FLOAT
5	1	6A10000-005	WIRE HARNESS, RIGHT FLOAT
6	1	7277-2-5	CIRCUIT BREAKER, 5 AMP
7	1	73F-250-32-NL	CONNECTOR, FEMALE, 12-10 AWG
8	1	73M-250-32-NL	CONNECTOR, MALE, 12-10 AWG
9	8	21A09005-262	CLIP, GEAR POSITION SWITCH HOLDER
10	8	S1635-1	PIN
11	8	S1636-1	SOCKET
12	8	S1637-1	HOUSING
13	8	S1637-2	HOUSING
14	1	W23-X1A1G-40	CIRCUIT BREAKER, 40 AMP, 12VDC

ELECTRICAL SCHEMATIC PRE SERVICE LETTER 233

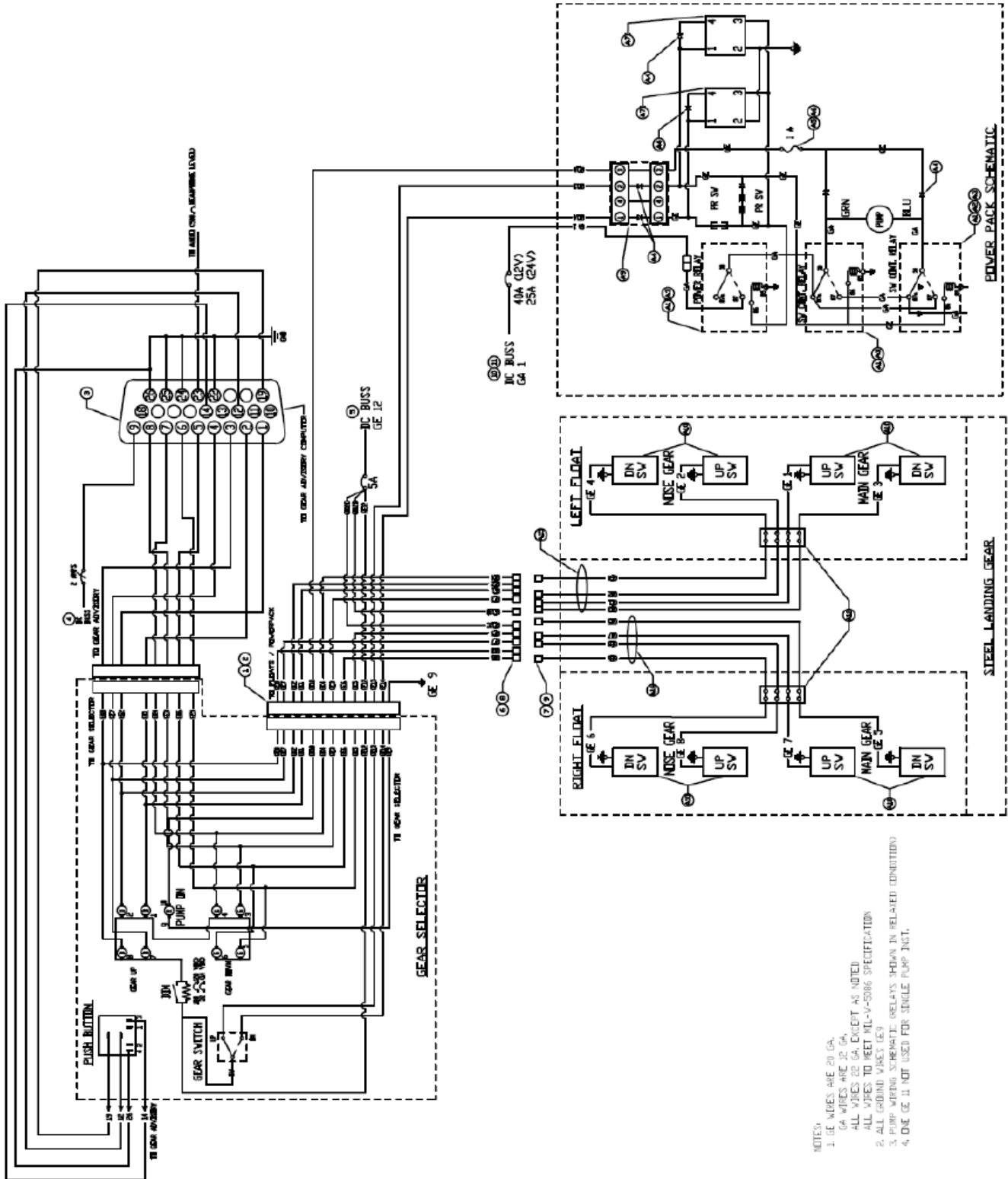

PARTS MANUAL
2100 FLOATS ON CESSNA 170

ITEM	QTY	PART NO.	PART DESCRIPTION
1	1	4A11000-011	ASSEMBLY, GEAR SELECTOR WIRING HARNESS
3	1	4A11000-014	ASSEMBLY, WIRING HARNESS, GEAR ADVISORY
4	1	7277-2-2	KLIXON CIRCUIT BREAKER, 2 AMP
5	1	7277-2-5	KLIXON CIRCUIT BREAKER, 5 AMP
6	8	S1635-1SF	PIN
7	8	S1636-1	SOCKET
8	8	S1637-1	HOUSING
9	8	S1637-2	HOUSING
11	1	W-23-X1A1G-40	BREAKER, CIRCUIT, 40AMP
A1	3	0-332-209-211	RELAY, 24V, 5 PRONG
A3	3	BR05FW	SOCKET, 5 PRONG, PLASTIC
A4	7	1N4004	DIODE, 2-1/2"
A5	1	AGC-1	FUSE, 250V, (S2565-1)
A6	1	3453LF2A	FUSE HOLDER
A7	2	1005042	ASSEMBLY, TIMER RELAY HARNESS (12V SYSTEM)
A9	1	1004949	CABLE, DIODE ADAPTER
A10	8	5801	SWITCH, SENSOR
A12	2	4-140	4 LUG TERMINAL BLOCK
A15	1	6A10000-004	ASSEMBLY, WIRE HARNESS, LEFT FLOAT
A16	1	6A10000-005	ASSEMBLY, WIRE HARNESS, RIGHT FLOAT

GEAR CONTROL (ROUND)

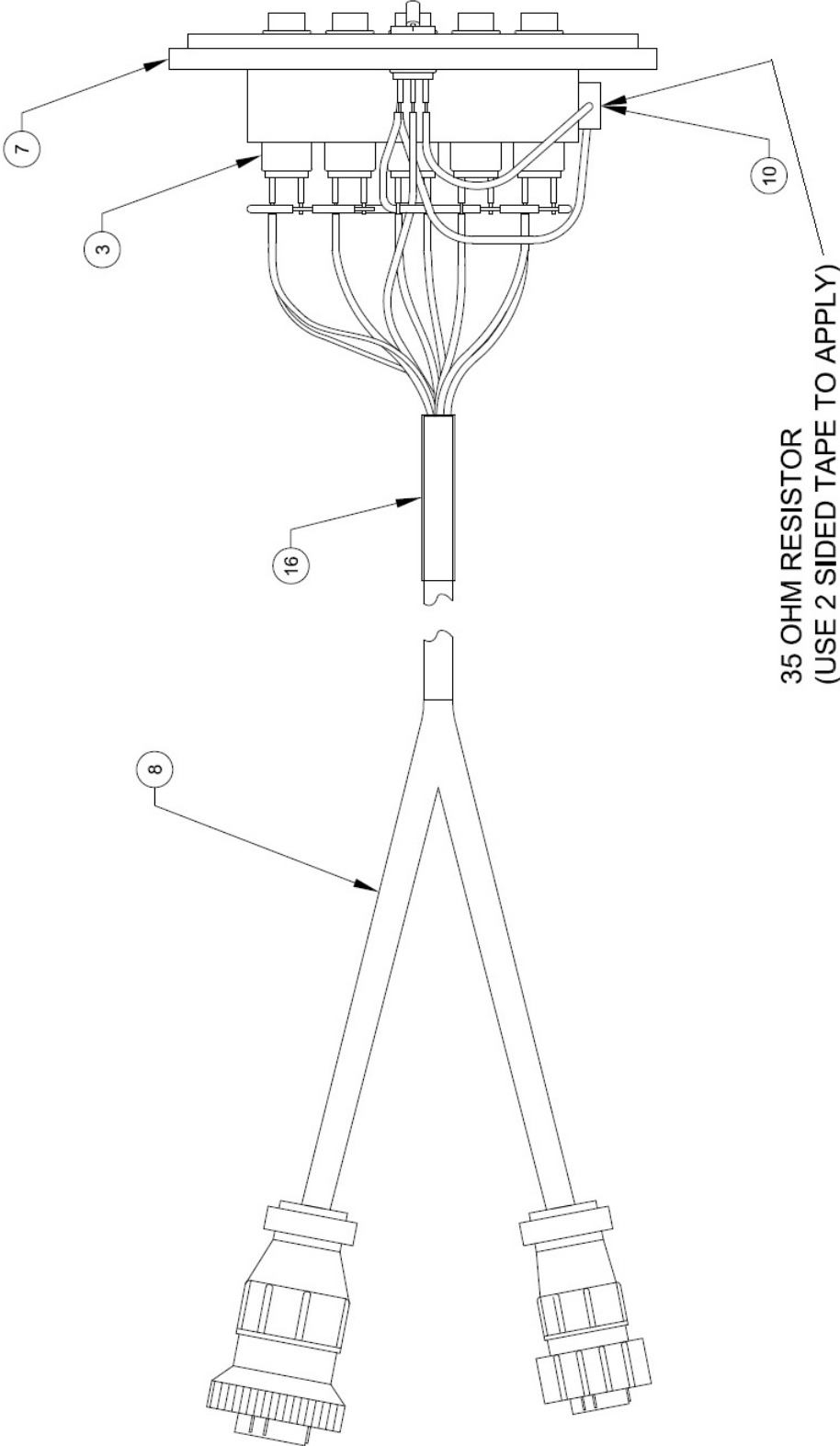

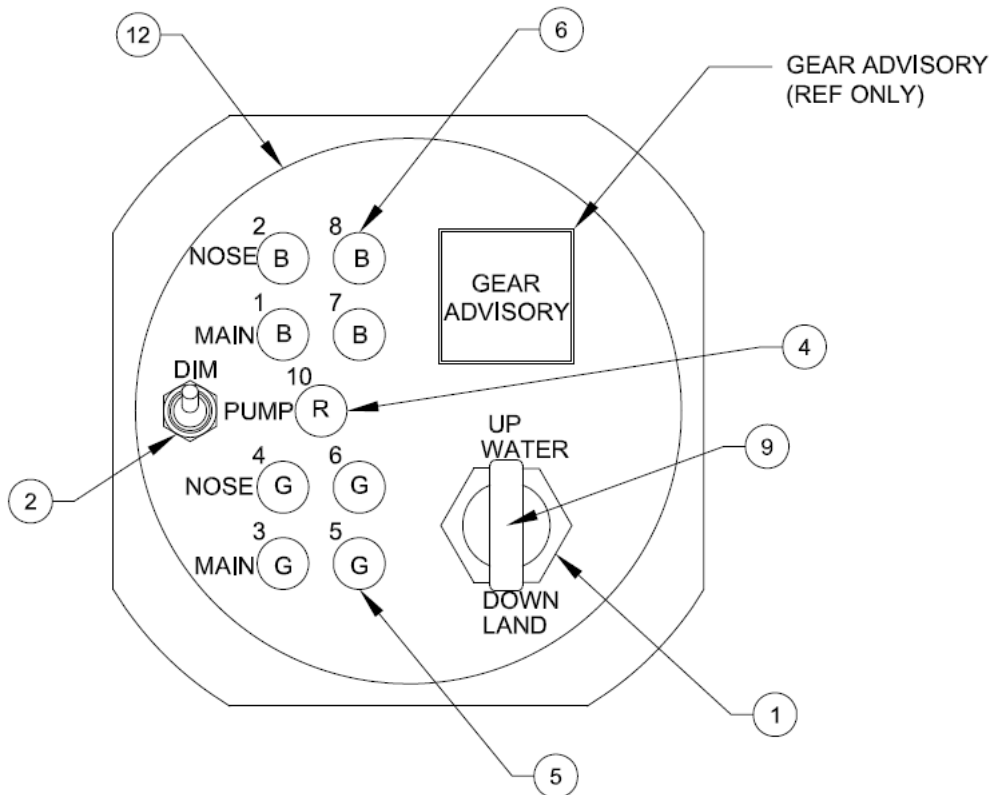
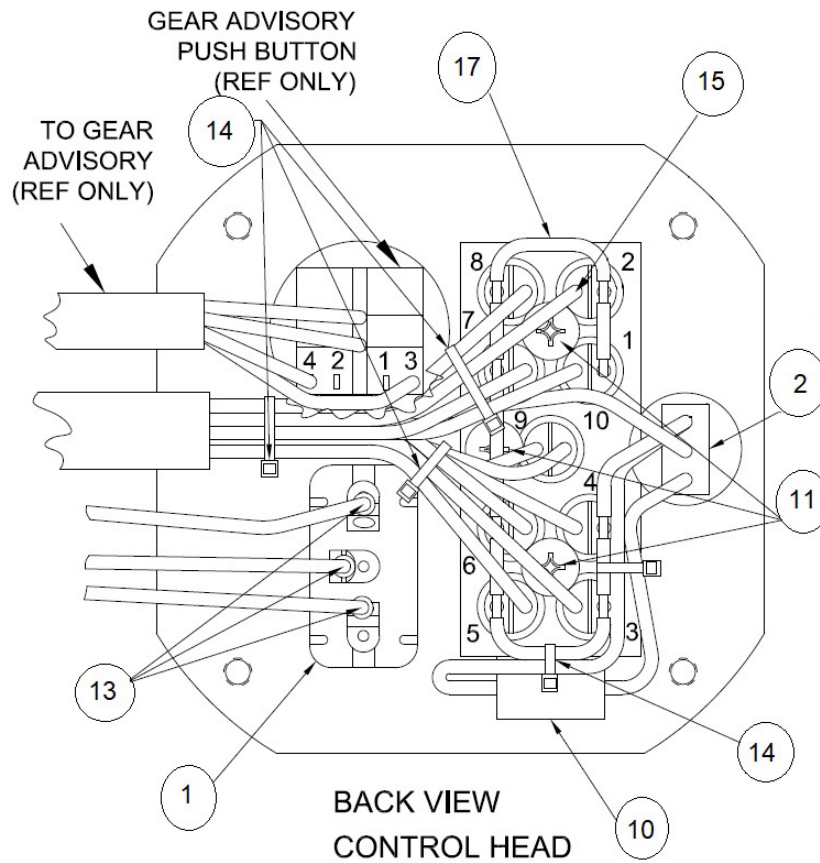

ITEM	QTY	PART NO.	PART DESCRIPTION
-	1	21A11000-009	GEAR SELECTOR ASSY. ROUND (12V)
1	1	8857K44	SWITCH
2	1	A101SYCB	TOGGLE SWITCH, SPDT, ON-ON
3	9	515-0012	SOCKET
4	1	507-3914-1431-600F	INDICATOR LAMP, 14V, RED
5	4	507-3914-1432-600F	INDICATOR LAMP, 14V, GREEN
6	4	507-3914-1434-600F	INDICATOR LAMP, 14V, BLUE
7	1	21A11179-001	BLOCK, GEAR CONTROL
8	1	4A11000-008	HARNESS ASSEMBLY, GEAR SELECTOR
9	1	21A11259-003	GEAR SWITCH KNOB
10	1	RH-5-35	RESISTOR, 14V, DALE RH5 5W
11	3	AN526-632R8	SCREW, TRUSS HEAD, 6-32
12	1	10B3-6202	PLACARD, ROUND 2100 GEAR SELECTOR
13	3	R-3	RING CONNECTOR, #6, 20 AWG, RED
14	5	PLT1M-M	CABLE TIE
15	16 IN	HIXR-3/16	SHRINK WRAP, 3/16, WHITE
16	3 IN	HS105-1/2-0	HEAT SHRINK TUBING
17	6 IN	22759-16-20-9	WIRE, 20 AWG, WHITE

GEAR CONTROL (RECTANGLE)

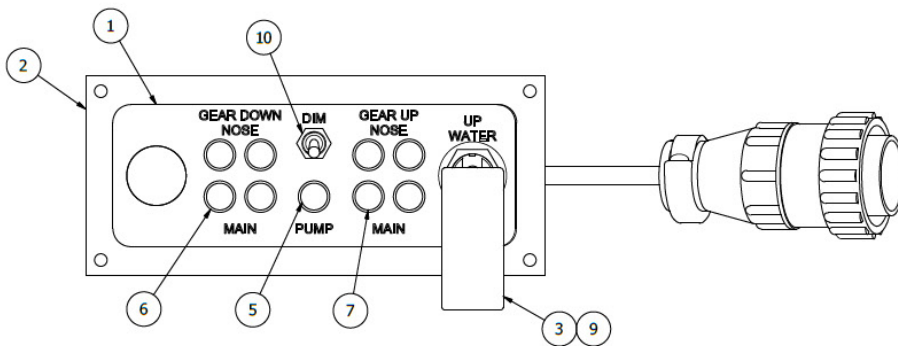
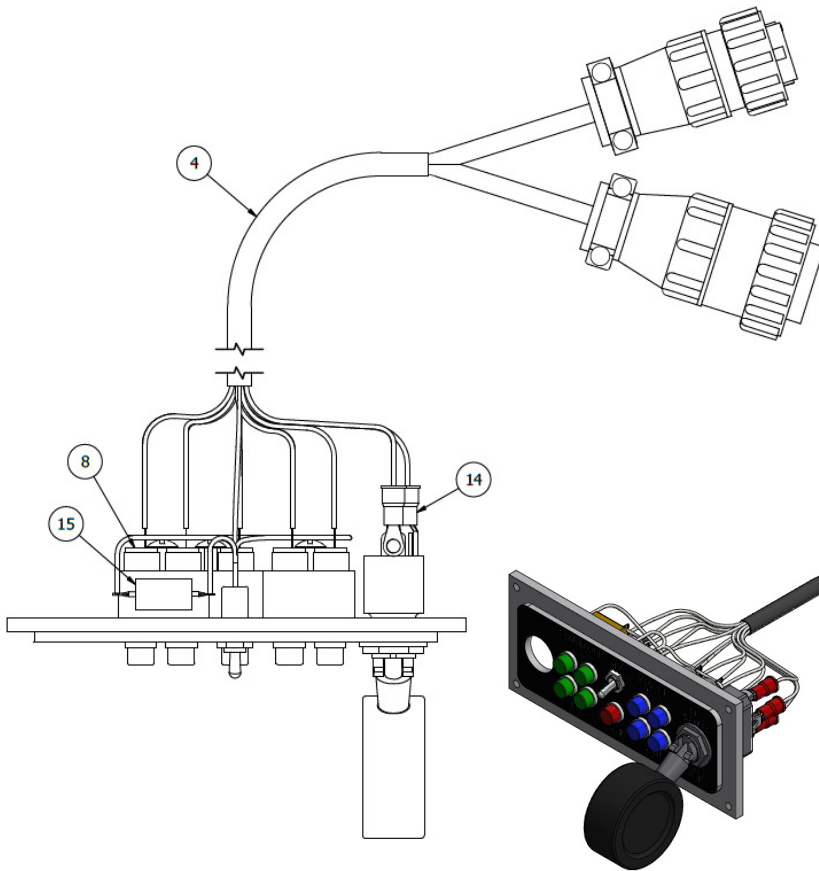
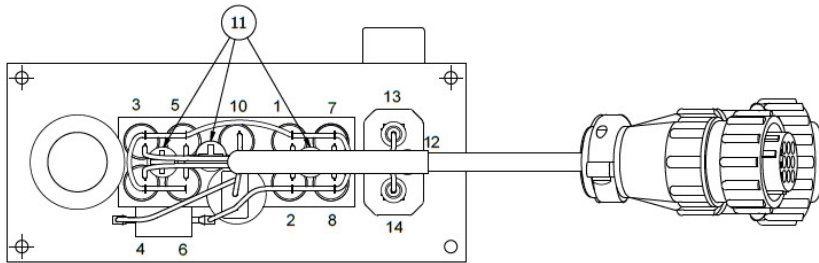

ITEM	QTY	PART NO.	PART DESCRIPTION
-	1	21A11000-010	ASSEMBLY, INDICATOR, GEAR CONTROL, SQUARE, 12V
1	1	10B3-6277	PLACARD, GEAR CONTROL SQUARE
2	1	21A11179-002	BLOCK GEAR CONTROL SQUARE
3	1	21A11259-003	GEAR SWITCH KNOB
4	1	4A11000-008	WIRING HARNESS ASSY. SELECTOR
5	1	507-3914-1431-600F	LAMP LIGHT, RED 14V
6	4	507-3914-1432-600F	LAMP LIGHT, GREEN 14V
7	4	507-3914-1434-600F	LAMP LIGHT, BLUE, 14V
8	9	515-0012	SOCKET
9	1	8857K44	SWITCH
10	1	A101SYCB	TOGGLE SWITCH
11	3	AN526C632R8	SCREW, TRUSS HEAD MACHINE, 6-32 THREAD, 1/2" LENGTH
12	12"	HS105-3/32-0	HEAT SHRINK, TUBING - BLACK
13	8	PLT1M-M	CABLE TIE, NYLON, WHITE, 4" (SMALL)
14	3	R-3	TERMINAL, RING #6 STUD, 16-22 AWG, RED
15	1	RH-5-35	RESISTOR, 14V, DALE RH5 5W