



WIPLINE FLOATS • SKIS • MODIFICATIONS • AIRCRAFT SALES
AVIONICS • INTERIOR • MAINTENANCE • PAINT REFINISHING



**PARTS MANUAL
FOR
WIPLINE MODEL 2100 FLOATS
ON
CESSNA 172 & 175**

Revision R

1700 Henry Ave. - Fleming Field (KSGS), South St. Paul, MN 55075
Ph: 651.451.1205 Fax: 651.457.7858
www.wipaire.com

THIS PAGE INTENTIONALLY LEFT BLANK

LOG OF REVISIONS

Revision	Pages Affected	Description	Date
A	55-59	Added new brake assembly & shifted table of contents.	12/12/2005
B	44, 52	Main and nose gear cylinder retract p/n change.	3/20/2006
C	20-26	Changed P/Ns for float deck covers.	8/3/2006
D	All	Changed P/Ns for Main Gear Bushings. Added part number and revision to all pages. Ref 4- Drag Wire 1002111 was 21A02000-136. Ref 10 Wire Pull 21A02462-005 was 21A02519-008.	10/31/2006
E	44, 51	Hydraulic Cylinder part number change.	7/21/2007
F	All	Many pages changed with updated part numbers for parts. New figure added for water rudder.	9/1/2010
G	All	Reformatted entire manual, update to Part Sales Dept page, added new warranty and customer information, updated hyd. pump, gear selector, strut, step, steering/retract, wires and spreader bar, electrical schematic images and BOMS, corrected multiple clerical errors and incorrect part/item callouts, added Grove Nose wheel, washer 415067 was 359071.	5/28/2013
H	3	Removed Warranty Claim Form.	3/31/2016
J	9, 10, 13, 15, 18-19, 43, 45, 47, 55-56, 59, 68, 82	Updated skins in Amphibian and Seaplane Hull Assembly drawings and part numbers. Changed Bulkhead Support 21A01158-177 to 21A01158-175 in item 5 on Amphibian Hull Assembly. Changed 21A01000-275 to Assembly Spray Rail R. and 21A01000-274 to Assembly Spray L. in Seaplane Hull Assembly. Added Item 32 in Lower Nose Gear Assembly drawing and added Plate – Bearing, Nose Spring and hardware part numbers. Changed Bolt AN4-13A to NAS6204-17 in Main Gear Retraction. Changed Bolt AN5-11 Changed Switch Screw MS35206-215 to MS24693-S6. Updated Pad 66-111 to 066-111 and Rivet 105-2 to 066-001 in Main Gear Wheel Grove section. Changed Washer NAS114D0763J to NAS1149D0763J in Struts, Wires, Spreader Bars section. Connector Assembly 2601048-200 no longer available, replaced with Female Connector 73F- 250-32-NL and Male Connector 73M-250-32-NL.	11/4/2019
K	All	Reformatted manual in new software. Updated sections and created new drawings for bulkhead assemblies. Created sections for skins. Added 3A07005-178 Clip, Switch, Nose & Main to Nose Gear Retraction Assembly. Updated drawing for Gear Control (Rectangle) and the parts list. Changed Bushing 1001011 to 1001100 in Main Gear Retraction. Updated part numbers in Grove/Wipaire and Cleveland/Parker Main Wheel sections.	6/1/2020
L	All	Added Cessna 175 model to title page. Added note about nose and main gear tire/tube. Updated Tire and Tube part numbers AA1D4 and XA1AC. Changed 21A01158-203 to 21S01158-203. Updated bottom skins and stiffeners. Added note about Wipaire drawing 1011065 for alternate part numbers. Added sections for Pre/Post Service Letter 228 for Hydraulics and Electrical sections. Updated Hydraulic System Installation section image and parts list. Updated Hydraulic Pump Assembly 1011849 and 1011850 image and parts list. Updated Hydraulic Pump Overview image and parts list. Updated Electrical Schematic image and parts list. Added 1001431 Gear Control (G1000 Only) image and parts list.	5/10/2021
M	76	Changed 010-026 Seal to 471570 Seal, Timken.	5/26/2022
N	60, 82-83	Updated Pump Out Cup and Valve image and parts. Updated image and parts list in Main Gear Wheel Grove/Wipaire Assembly section.	1/30/2023
P	89-90	Updated parts list in Struts, Wires, & Spreader Bars section.	11/29/2023
R	120, 122, 124	Corrected bulb part numbers in gear control indicator assemblies.	9/23/2024

View most current version of parts manual at www.wipaire.com.

THIS PAGE INTENTIONALLY LEFT BLANK

CONTENTS

FLOAT PART SALES DEPARTMENT OPERATIONS	6
INTRODUCTION	7
SECTION 1 HULL BULKHEAD ASSEMBLIES.....	9
SECTION 2 WHEEL WELL ASSEMBLY	31
SECTION 3 SKINS & STIFFENERS	35
SECTION 4 TOP DECK ASSEMBLY.....	45
SECTION 5 EXTRUSIONS	53
SECTION 6 PUMPER TUBE INSTALLATION.....	59
SECTION 7 WATER RUDDER, RETRACT HANDLE, & STEERING AND RETRACT SYSTEM	61
SECTION 8 LANDING GEAR	69
SECTION 9 STRUTS, STEPS, WIRES AND SPREADER BARS	87
SECTION 10 HYDRAULIC SYSTEM	93
SECTION 11 ELECTRICAL.....	113

FLOAT PART SALES DEPARTMENT OPERATIONS

Parts Sales:

Wipaire, Inc.

1700 Henry Avenue – Fleming Field

South St. Paul, MN 55075

Telephone: (651) 306-0459

Fax: (651)-306-0666

Website: www.wipaire.com

Email: customerservice@wipaire.com

Note: Any information not found in this manual for strut package parts and other installation items refer to the installation drawing package provided with the STC at the time of float installation. Additional drawing copies are available for purchase through the Wipaire Customer Service Department.

Parts Ordering

Purchase orders should include:

1. Purchase order number
2. Name of person placing order
3. Invoicing information:
 - a. Customer name - company or individual
 - b. Address
 - c. Phone and fax number
4. Shipping information:
 - a. Address (if different from invoice address)
 - b. Method of shipment/preferred carrier
5. Aircraft model, float model, and serial numbers
6. Wipaire part number; name; type, e.g. left or right; quantity
7. Payment method: VISA, MasterCard, C.O.D. (Collect on Delivery) (U.S. customers only), pre-payment by check or wire transfer, open account (see Credit Policy)

INTRODUCTION

All references in this manual to LEFT and RIGHT are from the perspective of the pilot's seat with the floats fully installed and ready for floatplane operation.

The following is a list of abbreviations that may appear in the description nomenclature fields of this manual:

AB	Afterbody	Inbd.	Inboard
Amphib.	Amphibious	Lg.	Large
AR	As Required	Lt.	Left
Assy.	Assembly	Lwr.	Lower
Brkt.	Bracket	Opt.	Optional
Btm.	Bottom	Otbd.	Outboard
Bulk.	Bulkhead	Reinf.	Reinforcement
Ctr.	Center	Rr.	Rear
Cyl.	Cylinder	Rt.	Right
Ft.	Front	Sm.	Small
Ftg.	Fitting	SN	Serial Number
Fus.	Fuselage	Spr.	Spreader
Fwd	Forward	Upr.	Upper
Horiz.	Horizontal	Vert.	Vertical
Hyd.	Hydraulic	W.W.	Wheel Well

USING THIS PARTS MANUAL

COVERAGE

Parts information is provided in this manual for the hulls and all "deck down" parts. For information on strut package parts and other aircraft installation items, refer to the installation drawing package provided with the STC at the time of float installation. Additional drawing copies are available for purchase through Wipaire Customer Service Department.

Name of main part in the section. Example: This part is showing the components made up in Bulkhead #1.

BULKHEAD #1

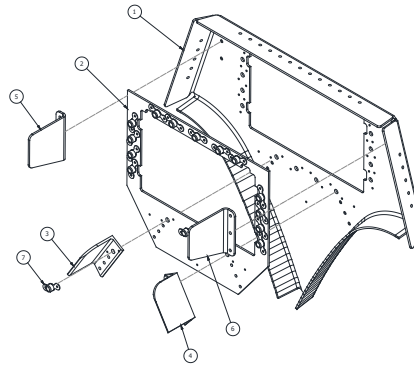

Main part image. If the image has numbers associated with it, then those numbers are item numbers shown in the table below.

Items with a (-) instead of a number represent the main part as an assembly. Other parts represent the parts included in the assembly.

ITEM	QTY	PART NO.	PART DESCRIPTION
-	1	1008815	ASSEMBLY BULKHEAD #1, 10000
1	1	1008797	PANEL, BULKHEAD #1
2	1	13A01156-085	DOUBLER #1 BULKHEAD
3	1	13A01357-049	CLEAT, SISTER KEEL ATTACH #1 BULKHEAD
4	1	13A01357-050	CLEAT, SISTER KEEL ATTACH #1 BULKHEAD
5	1	6A01156-054	ANGLE – TOP RAIL
6	1	6A01156-055	ANGLE – TOP RAIL
7	17	MS21047L4	NUT PLATE, SELF LOCKING

To order an individual part, order the part number associated with item number.

SECTION 1 HULL BULKHEAD ASSEMBLIES

CONTENTS

HULL ASSEMBLY - AMPHIBIAN.....	10
HULL ASSEMBLY - SEAPLANE	12
NOSE BUMPER - AMPHIBIAN	15
BULKHEAD #1.....	16
BULKHEAD #3.....	17
BULKHEAD #4.....	18
BULKHEAD #5.....	19
BULKHEAD #6.....	20
BULKHEAD #7 LEFT FLOAT	21
BULKHEAD #7 RIGHT FLOAT	22
BULKHEAD #8 LEFT FLOAT	23
BULKHEAD #8 RIGHT FLOAT	24
BULKHEAD #10.....	25
BULKHEAD #11.....	26
BULKHEAD #12.....	27
BULKHEAD #13.....	28
BULKHEAD #14.....	29

HULL ASSEMBLY - AMPHIBIAN

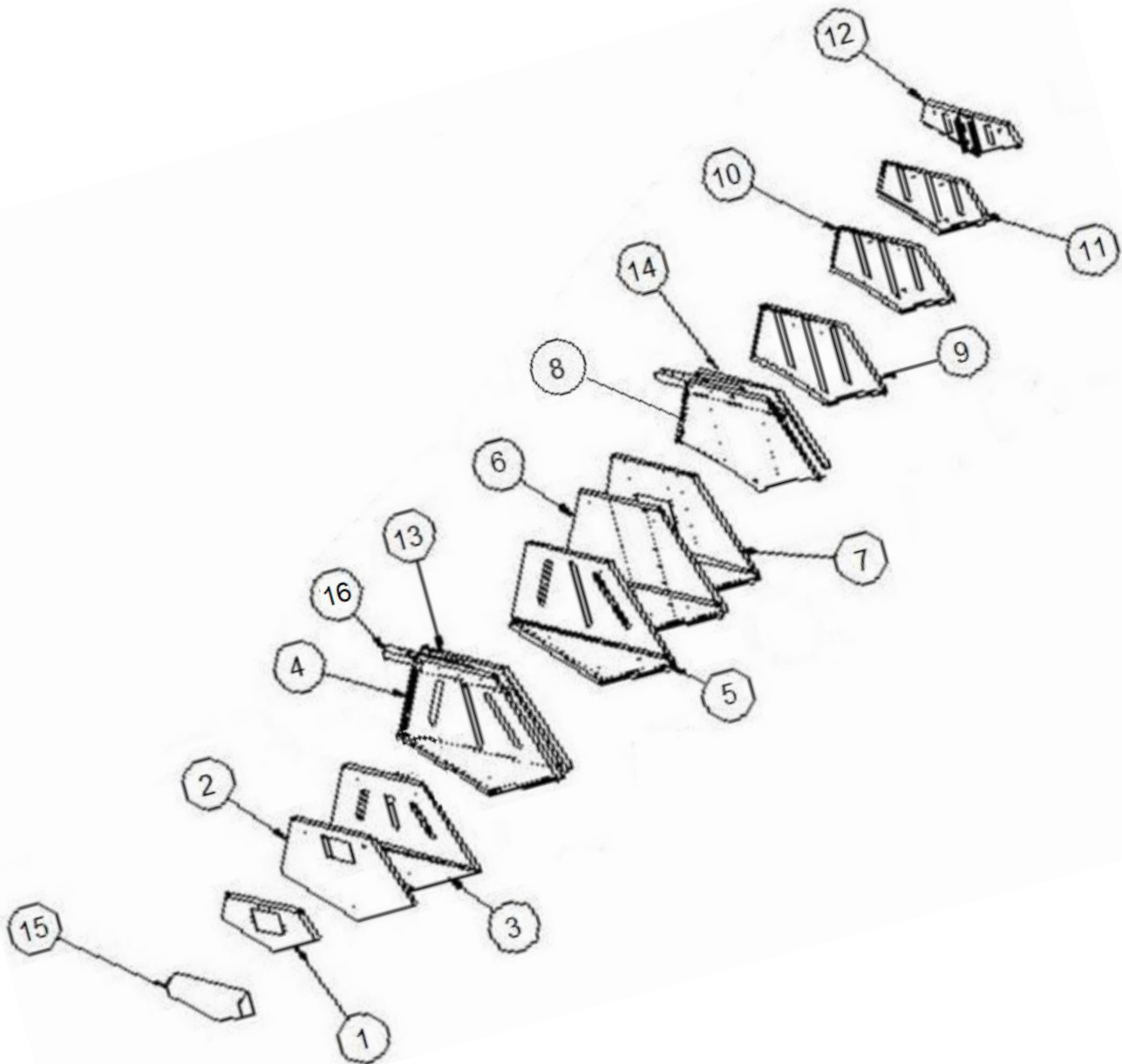

PARTS MANUAL
2100 FLOATS ON CESSNA 172 & 175

ITEM	QTY	PART NO.	PART DESCRIPTION
1	1	21A01163-067	ASSEMBLY, BULKHEAD #1
2	1	21A01000-265	ASSEMBLY, BULKHEAD #3
3	1	21A01000-261	ASSEMBLY, BULKHEAD #4
4	1	21A01000-253	ASSEMBLY, BULKHEAD #5
5	1	21A01000-252	ASSEMBLY, BULKHEAD #6
6 LT.	1	21A01000-267	ASSEMBLY, BULKHEAD #7, LH
6 RT.	1	21A01000-266	ASSEMBLY, BULKHEAD #7, RH
7 LT.	1	21A01000-263	ASSEMBLY, BULKHEAD #8, LH
7 RT.	1	21A01000-264	ASSEMBLY, BULKHEAD #8, RH
8	1	21A01000-262	ASSEMBLY, BLKHD 10, COMP
9	1	21A01000-395	ASSEMBLY, BULKHEAD #11
10	1	21A01000-396	ASSEMBLY, BULKHEAD #12
11	1	21A01000-397	ASSEMBLY, BULKHEAD #13
12	1	21A01000-250	ASSEMBLY, BULKHEAD #14
13	1	21A01000-260	ASSY. SPR. BAR PANEL FWD
	1	21A01163-065	PANEL – SPR. BAR
	1	21A01326-013	ANGLE – SIDE L.
	1	21A01326-014	ANGLE – SIDE R.
	1	AN4-5A	BOLT, 1/4-28, 0.1875 GRIP, UNDRILLED, STEEL
	1	NAS1149F0463P	WASHER, 0.265 ID, 0.063 THK, STEEL
	1	MS21044N4	NUT, LOCKING, REGULAR HEIGHT, 1/4-28 UNF
14	1	21A01000-259	ASSY. SPR. BAR PANEL AFT
	1	21A01163-065	PANEL – SPR. BAR
	1	21A01326-009	ANGLE – SIDE L.
	1	21A01326-010	ANGLE – SIDE R.
	1	AN4-5A	BOLT, 1/4-28, 0.1875 GRIP, UNDRILLED, STEEL
	1	NAS1149F0463P	WASHER, 0.265 ID, 0.063 THK, STEEL
	1	MS21044N4	NUT, LOCKING, REGULAR HEIGHT, 1/4-28 UNF
15	1	21A01000-295	ASSEMBLY, NOSE BUMPER, 2100
16	2	21A03115-001	TUBE – SPR. BAR MOUNTING
	6	AN4-22A	BOLT, 1/4-28, 1.8125 GRIP, UNDRILLED, STEEL
	12	NAS1149D0416J	WASHER, 0.265 ID, 0.016 THK, ALUMINUM
	12	NAS1149D0463J	WASHER, 0.265 ID, 0.063 THK, ALUMINUM
	6	MS21044N4	NUT, LOCKING, REGULAR HEIGHT, 1/4-28 UNF

HULL ASSEMBLY - SEAPLANE

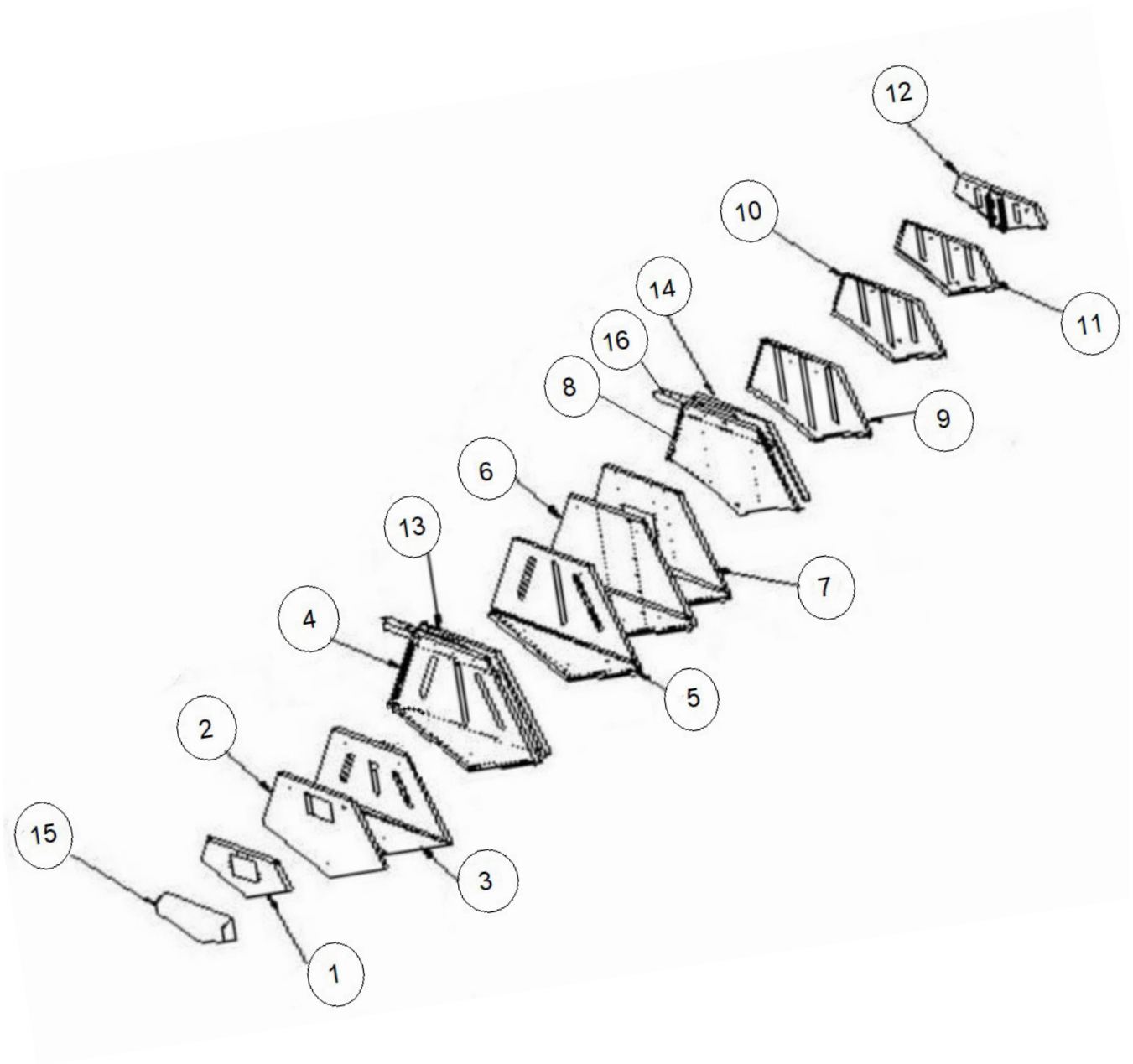

PARTS MANUAL
2100 FLOATS ON CESSNA 172 & 175

ITEM	QTY	PART NO.	PART DESCRIPTION
1	1	21A01163-067	BULKHEAD #1
	1	21S01150-134	COVER – NOSE GEAR OPENING
	A/R	MS21059L3	PLATE NUT
2	1	21A01000-265	ASSY BULKHEAD #3
	1	21A01158-184	BULKHEAD
	1	21A01326-006	ANGLE – NOSE BOX ATTACH
	1	21A01326-005	ANGLE – NOSE BOX ATTACH
3	1	21A01000-261	ASSY BULKHEAD #4
	1	21A01158-174	BULKHEAD – MAIN
	1	21A01158-175	SUPPORT – BULKHEAD LOWER
	1	3A01158-003	CLAMP, PUMP OUT TUBE
4	1	21A01000-253	ASSY BULKHEAD #5
	1	21A01158-178	BULKHEAD - MAIN
	1	21A01326-007	ANGLE – SIDE L.
	1	21A01326-008	ANGLE – SIDE R.
	1	21A01163-066	PANEL – SPR. BAR
	1	21A01158-177	SUPPORT – BULKHEAD LOWER
	1	3A01158-003	CLAMP, PUMP OUT TUBE
5	1	21A01000-252	ASSY BULKHEAD #6
	1	21A01158-189	BULKHEAD – MAIN
	1	21A01158-177	SUPPORT – BULKHEAD LOWER
	1	MS35489-19	GROMMET
6	1	21S01000-308	ASSY BULKHEAD #7
	1	21A01158-189	BULKHEAD - MAIN
	1	21A01158-177	SUPPORT – BULKHEAD LOWER
	1	3A01158-003	CLAMP, PUMP OUT TUBE
7	1	21S01000-309	ASSY BULKHEAD #8
	1	21A01158-189	BULKHEAD – MAIN
	1	21A01158-177	SUPPORT – BULKHEAD LOWER
	2	21S01158-203	ANGLE – A.B. SKIN ATTACH
	1	3A01158-003	CLAMP, PUMP OUT TUBE
8	1	21S01000-322	ASSY. – BULKHEAD #10
	1	21A01158-169	BULKHEAD - MAIN
	1	21A01326-011	ANGLE SIDE L.
	1	21A01326-012	ANGLE SIDE R.
	1	21A01163-066	PANEL – SPR. BAR
	2	21S01340-129	ANGLE – VERTICAL
	1	3A01158-003	CLAMP, PUMP OUT TUBE
9	1	21A01000-395	BULKHEAD #11
	1	21A01158-168	BULKHEAD PANEL
10	1	21A01000-396	BULKHEAD #12

ITEM	QTY	PART NO.	PART DESCRIPTION
	1	21A01158-167	BULKHEAD PANEL
11	1	21A01000-397	BULKHEAD #13
	1	21A01158-166	BULKHEAD PANEL
12	1	21A01000-250	ASSY. BULKHEAD #14
	1	21A01158-164	BULKHEAD - MAIN
	1	21A01158-165	CHANNEL – REIN.
	1	21A08156-130	PLATE – WATER RUDDER STOP
13	1	21A01000-260	ASSY. SPR. BAR PANEL FWD
	1	21A01163-065	PANEL – SPR. BAR
	1	21A01326-013	ANGLE – SIDE L.
	1	21A01326-014	ANGLE – SIDE R.
	1	AN4-5A	BOLT, 1/4-28, 0.1875 GRIP, UNDRILLED, STEEL
	1	NAS1149F0463P	WASHER, 0.265 ID, 0.063 THK, STEEL
	1	MS21044N4	NUT, LOCKING, REGULAR HEIGHT, 1/4-28 UNF
14	1	21A01000-259	ASSY. SPR. BAR PANEL AFT
	1	21A01163-065	PANEL – SPR. BAR
	1	21A01326-009	ANGLE – SIDE L.
	1	21A01326-010	ANGLE – SIDE R.
	1	AN4-5A	BOLT, 1/4-28, 0.1875 GRIP, UNDRILLED, STEEL
	1	NAS1149F0463P	WASHER, 0.265 ID, 0.063 THK, STEEL
	1	MS21044N4	NUT, LOCKING, REGULAR HEIGHT, 1/4-28 UNF
15	1	21S01738-001	NOSE BUMPER
16	2	21A03115-001	TUBE – SPR. BAR MOUNTING
	6	AN4-22A	BOLT, 1/4-28, 1.8125 GRIP, UNDRILLED, STEEL
	12	NAS1149D0416J	WASHER, 0.265 ID, 0.016 THK, ALUMINUM
	12	NAS1149D0463J	WASHER, 0.265 ID, 0.063 THK, ALUMINUM
	6	MS21044N4	NUT, LOCKING, REGULAR HEIGHT, 1/4-28 UNF

NOSE BUMPER - AMPHIBIAN

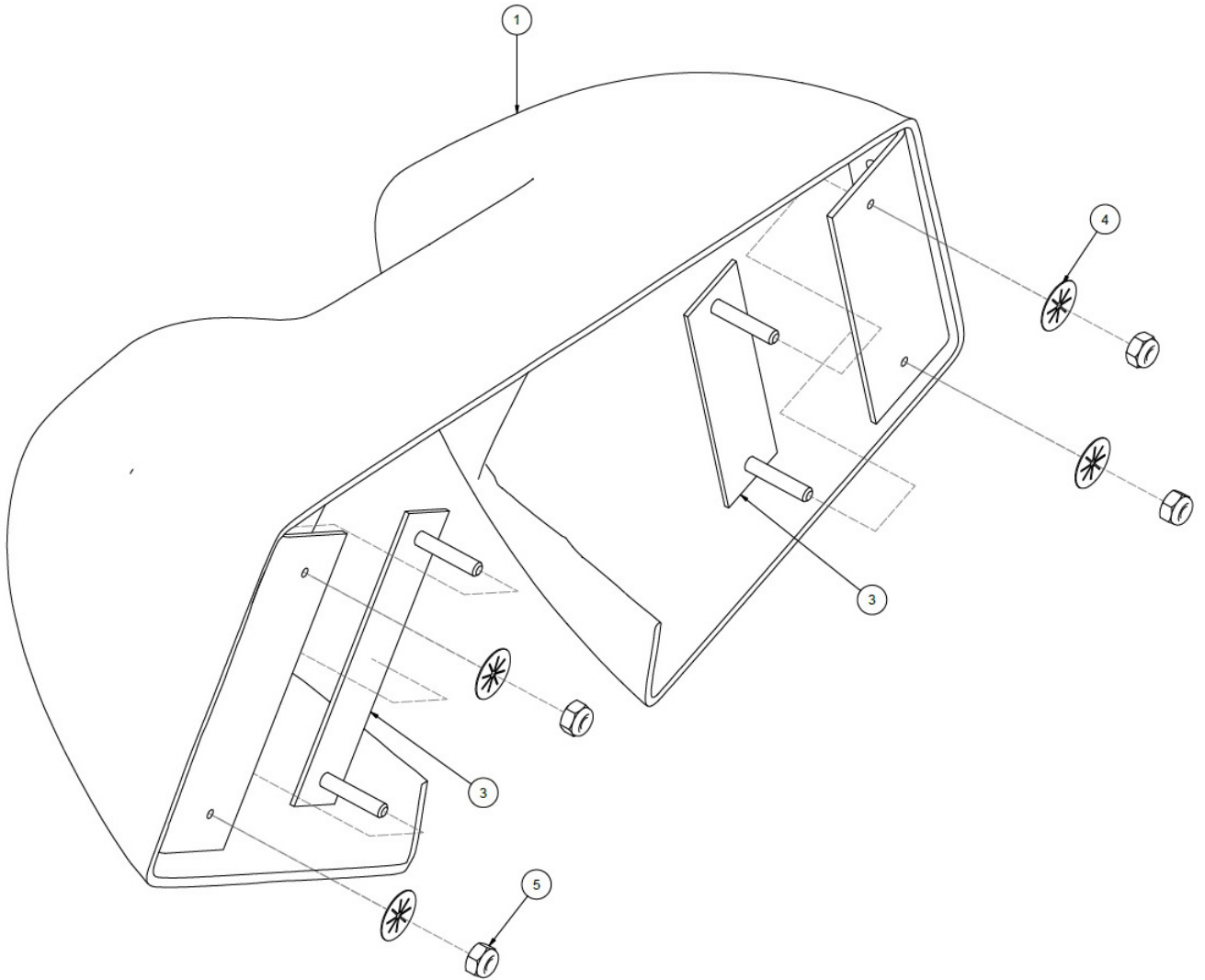

ITEM	QTY	PART NO.	PART DESCRIPTION
-	1	21A01000-295	ASSEMBLY, NOSE BUMPER, 2100
1	1	21A01000-295-1	NOSE BUMPER
2	2	21A01000-295-2	ANGLE, MOUNT, NOSE BUMPER
3	2	21A01000-295-3	PLATE, SCREW MOUNT, NOSE BUMPER
4	4	4HFW3	PUSH NUT WASHER
5	4	MS21044N3	NUT, LOCKING, REGULAR HEIGHT, 10-32 UNF
6	4	MS51958-67	SCREW, BUTTON HEAD

BULKHEAD #1

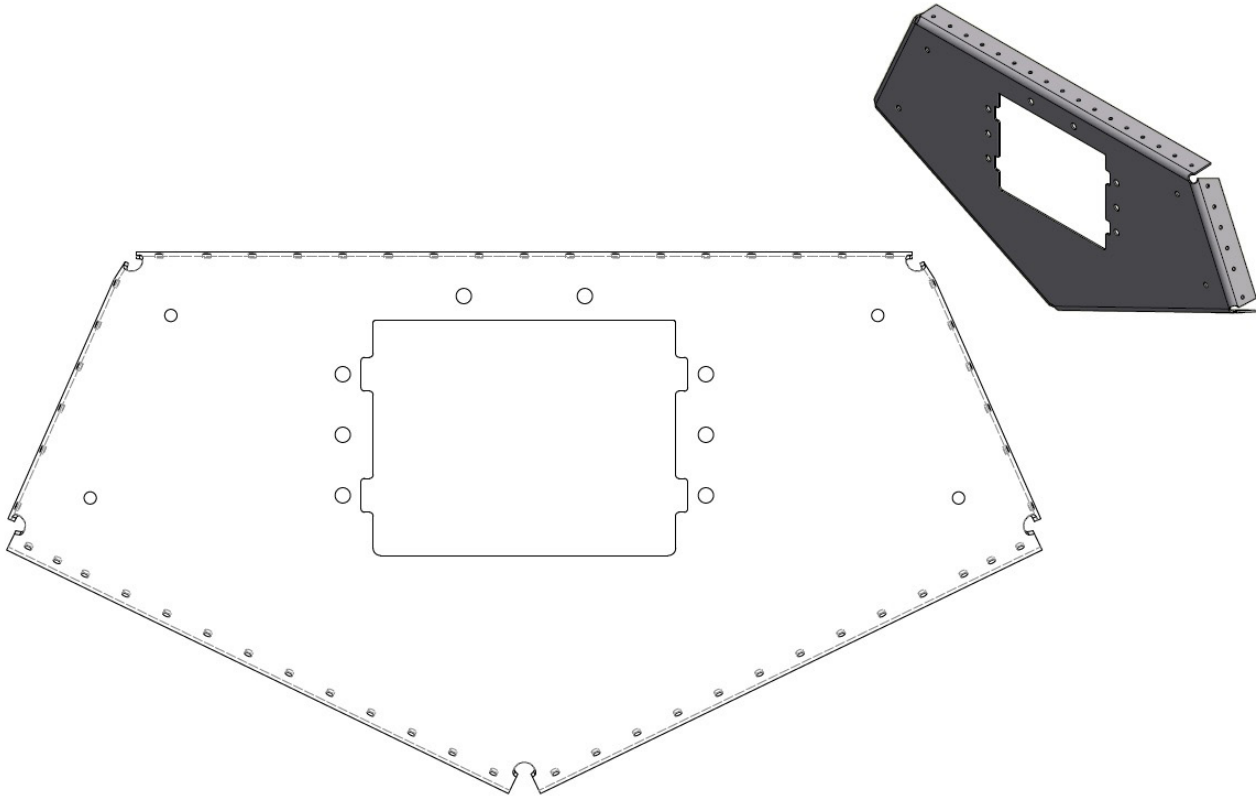

ITEM	QTY	PART NO.	PART DESCRIPTION
-	1	21A01163-067	BULKHEAD #1

BULKHEAD #3

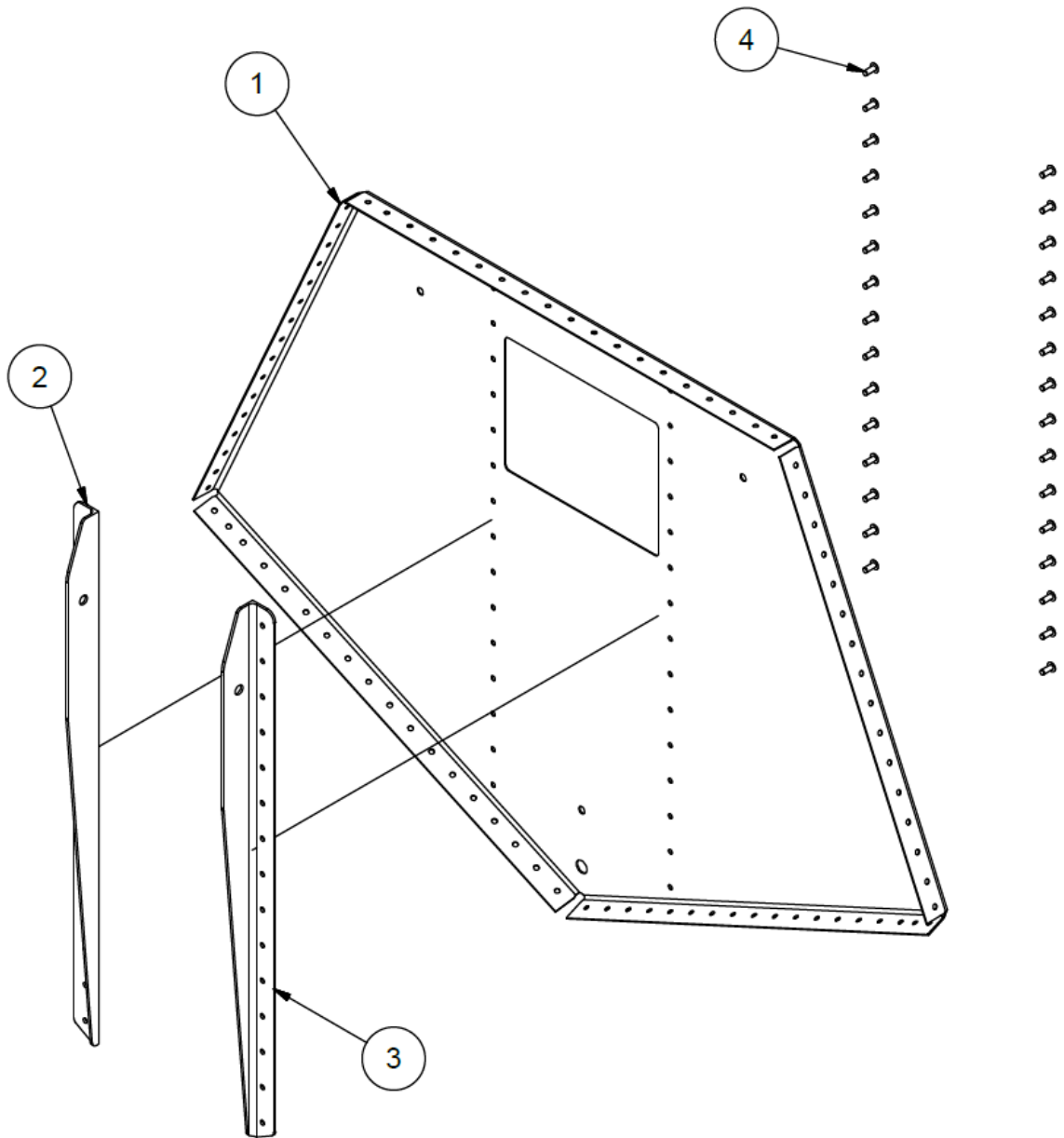

ITEM	QTY	PART NO.	PART DESCRIPTION
-	1	21A01000-265	ASSEMBLY, BULKHEAD #3
1	1	21A01158-184	BULKHEAD #3
2	1	21A01326-005	ANGLE, SUPPORT BULKHEAD #3 LT.
3	1	21A01326-006	ANGLE, SUPPORT BULKHEAD #3 RT.
4	30	AN470AD4-5	RIVET

BULKHEAD #4

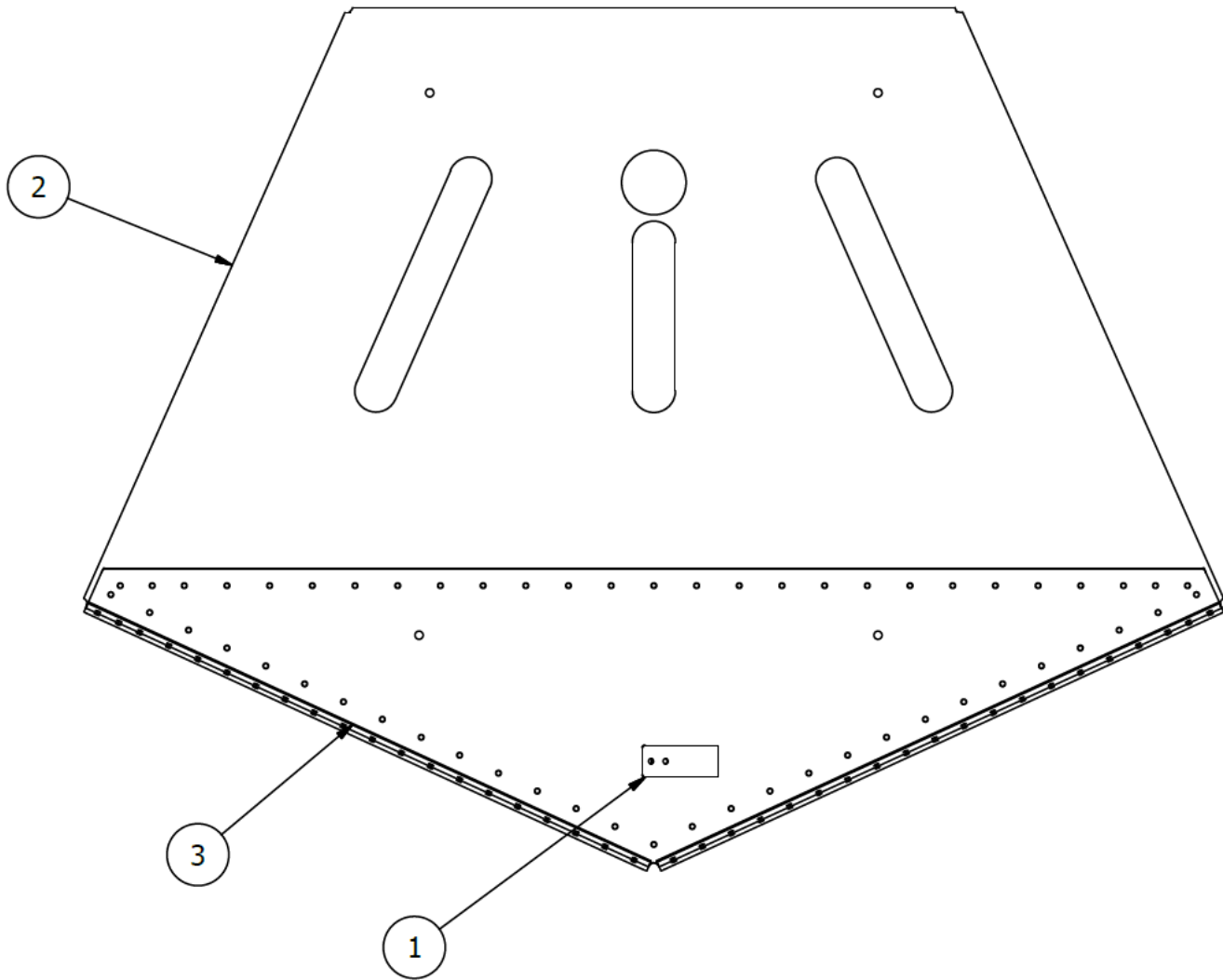

ITEM	QTY	PART NO.	PART DESCRIPTION
-	1	21A01000-261	ASSEMBLY, BULKHEAD #4
1	1	3A01158-003	CLAMP, PUMP OUT TUBE
2	1	21A01158-174	BULKHEAD #4 - FORMED
3	1	21A01158-175	BULKHEAD SUPPORT #4 - FORMED

BULKHEAD #5

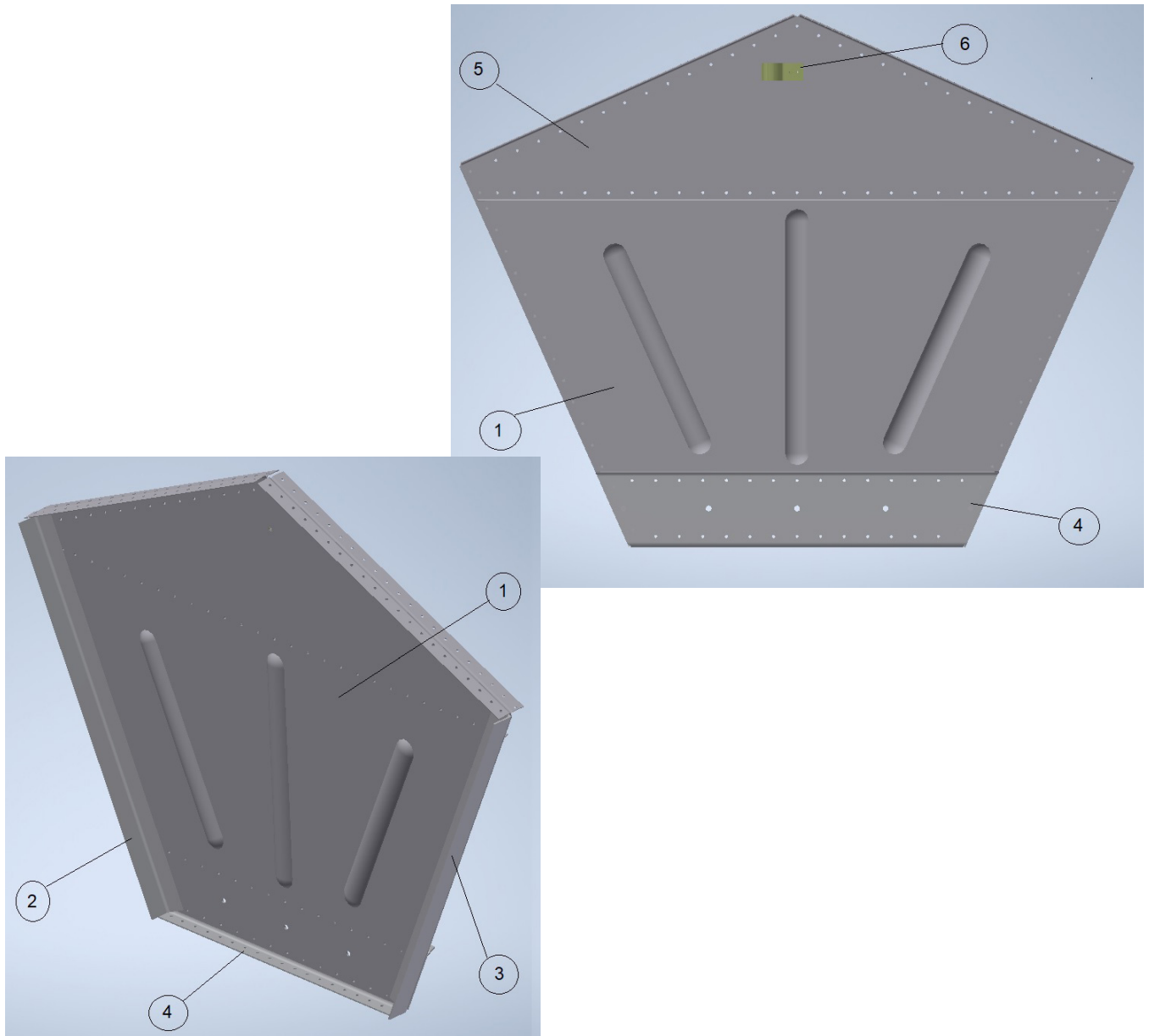

ITEM	QTY	PART NO.	PART DESCRIPTION
-	1	21A01000-253	ASSY BULKHEAD #5
1	1	21A01158-178	BULKHEAD - MAIN
2	1	21A01326-007	ANGLE - SIDE L.
3	1	21A01326-008	ANGLE - SIDE R.
4	1	21A01163-066	PANEL - SPR. BAR
5	1	21A01158-177	SUPPORT - BULKHEAD LOWER
6	1	3A01158-003	CLAMP, PUMP OUT TUBE

BULKHEAD #6

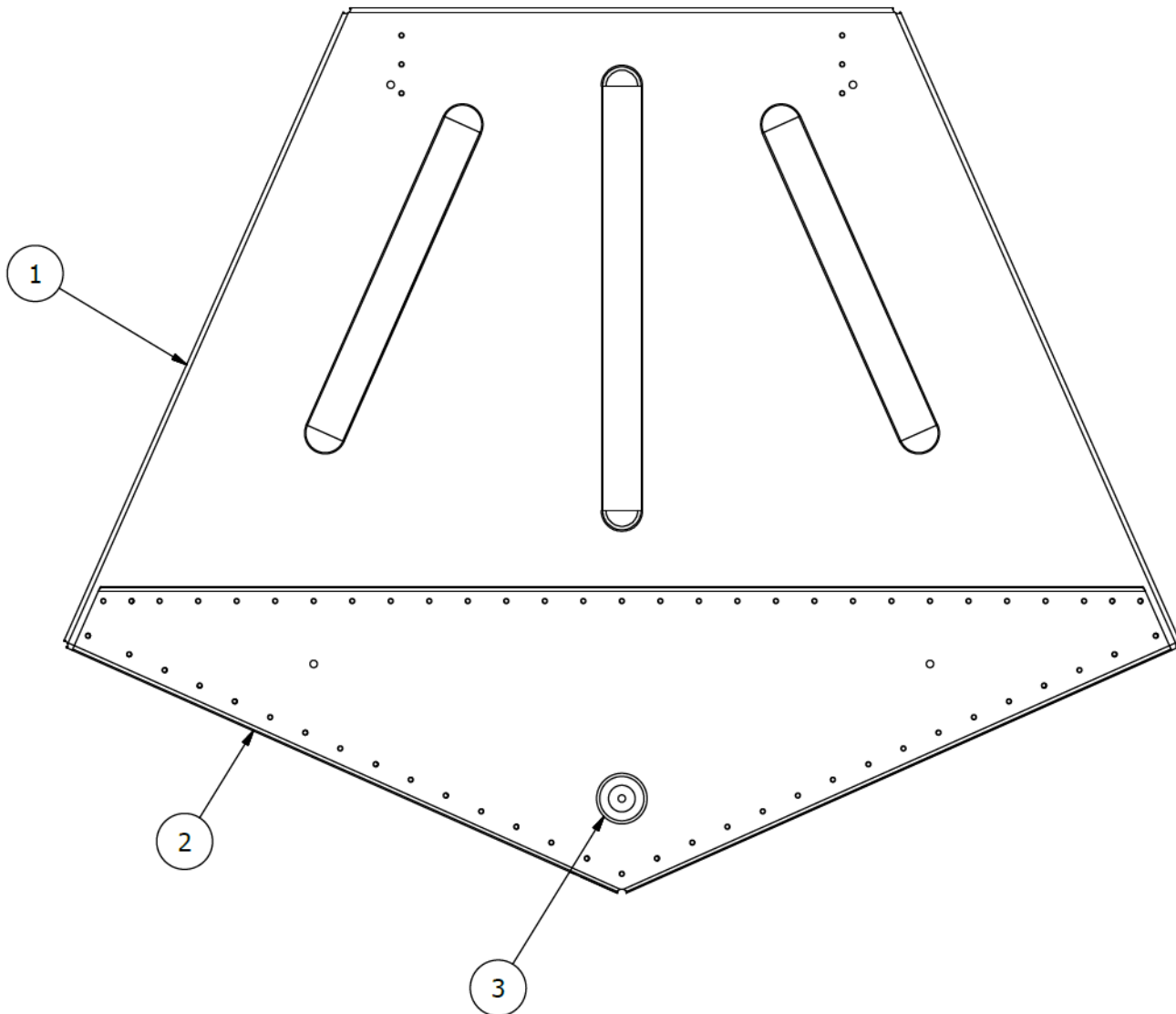

ITEM	QTY	PART NO.	PART DESCRIPTION
-	1	21A01000-252	ASSEMBLY, BULKHEAD #6
1	1	21A01158-189	BULKHEAD #6
2	1	21A01158-177	SUPPORT, BULKHEAD #6
3	1	MS35489-19	GROMMET, RUBBER

BULKHEAD #7 LEFT FLOAT

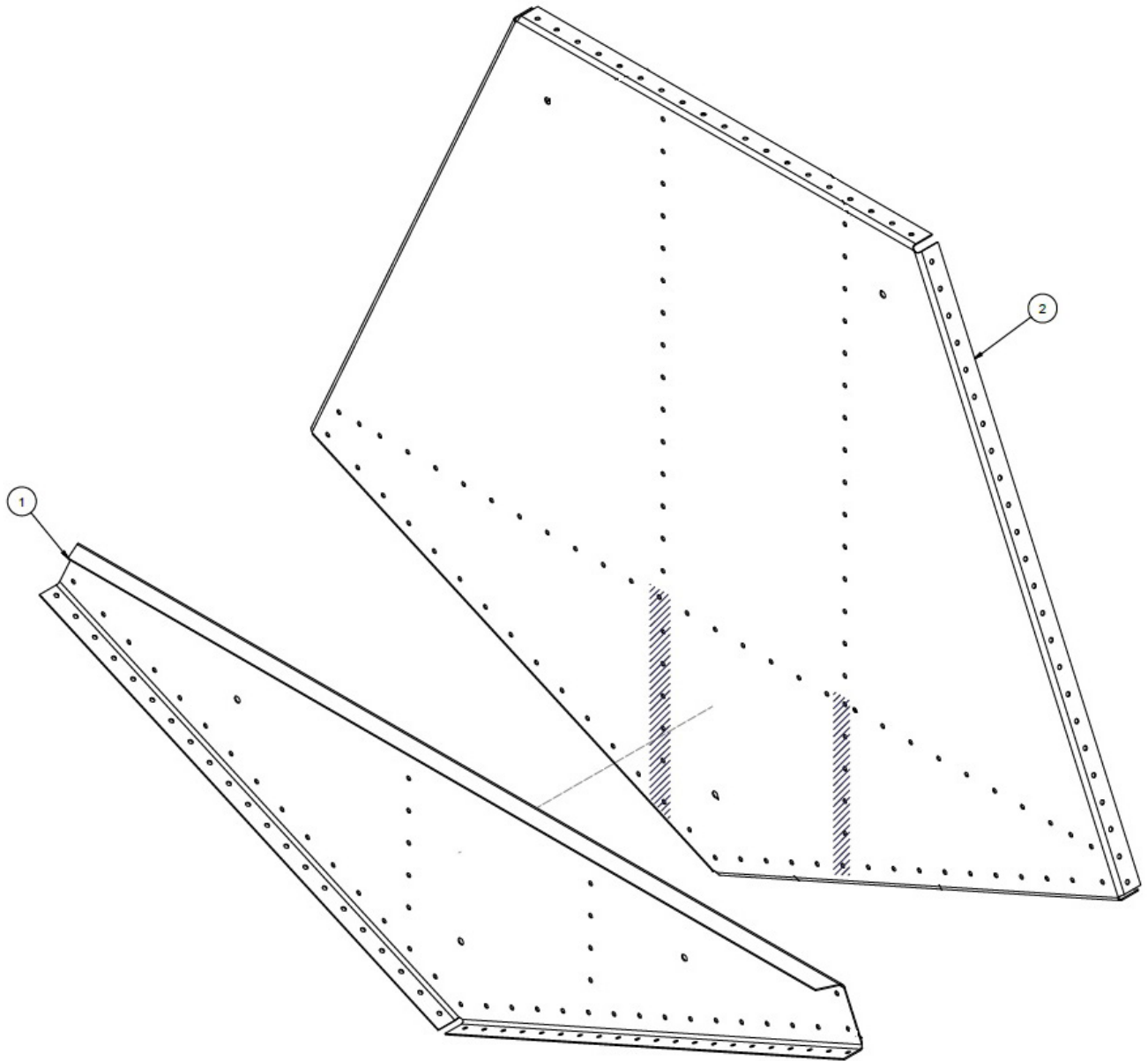

ITEM	QTY	PART NO.	PART DESCRIPTION
-	1	21A01000-267	ASSEMBLY, BULKHEAD #7, LH
1	1	21A01158-187	SUPPORT, BLKHD 7, RH, 2100
2	1	21A01158-181	BULKHEAD #7 - LH

BULKHEAD #7 RIGHT FLOAT

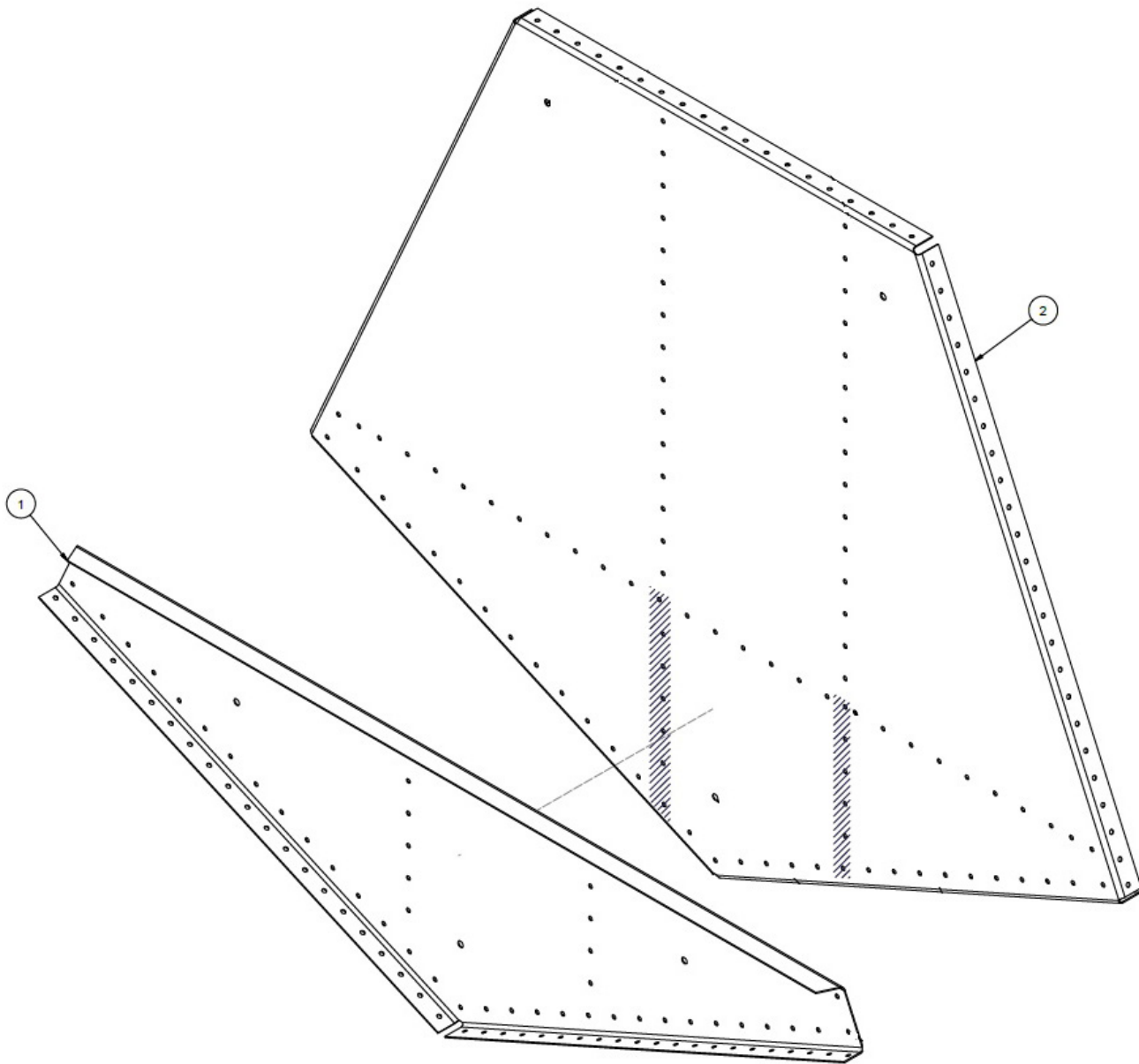

ITEM	QTY	PART NO.	PART DESCRIPTION
-	1	21A01000-266	ASSEMBLY, BULKHEAD #7, RH
1	1	21A01158-188	SUPPORT, BLKHD 7, LH, 2100
2	1	21A01158-182	BULKHEAD #7 - RH

BULKHEAD #8 LEFT FLOAT

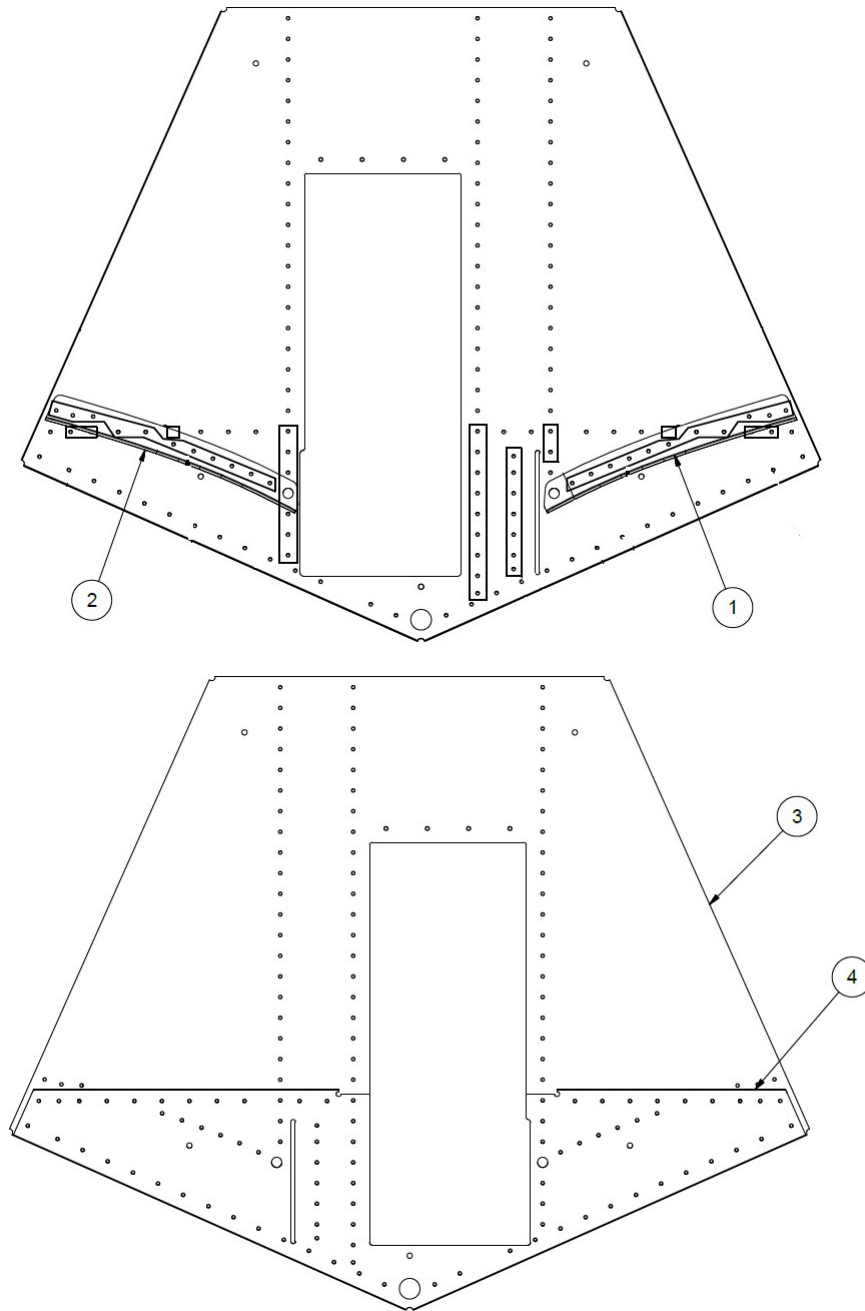

ITEM	QTY	PART NO.	PART DESCRIPTION
-	1	21A01000-263	ASSY, BULKHEAD #8, LH
1	1	21A01158-179	ANGLE - AFTERBODY ATTACH - RH
2	1	21A01158-180	ANGLE - AFTERBODY ATTACH - LH
3	1	21A01158-191	BULKHEAD #8 - LH - FORMED
4	1	21A01158-193	SUPPORT - LH - BULKHEAD #8

BULKHEAD #8 RIGHT FLOAT

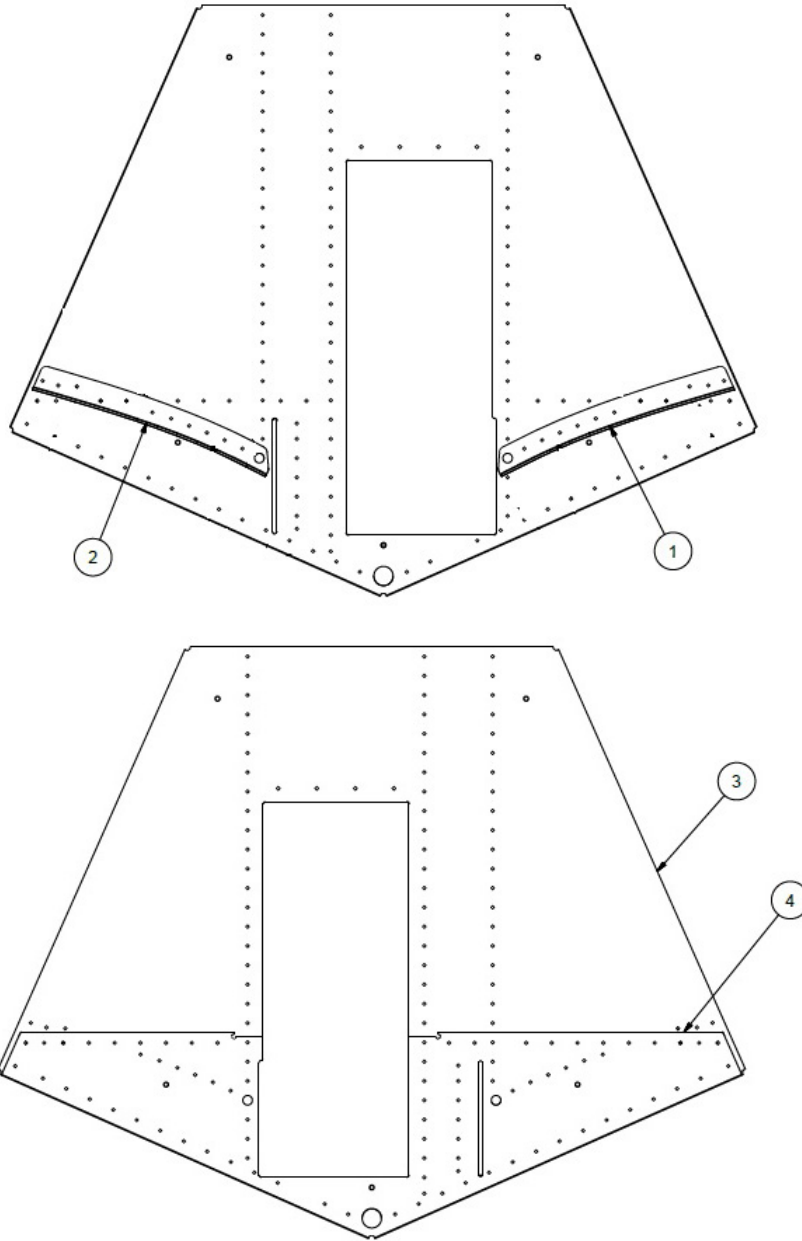

ITEM	QTY	PART NO.	PART DESCRIPTION
-	1	21A01000-264	ASSY, BULKHEAD #8, RH
1	1	21A01158-179	ANGLE - AFTERBODY ATTACH - RH
2	1	21A01158-180	ANGLE - AFTERBODY ATTACH - LH
3	1	21A01158-190	BULKHEAD #8 - RH - FORMED
4	1	21A01158-192	SUPPORT - RH - BULKHEAD #8

BULKHEAD #10

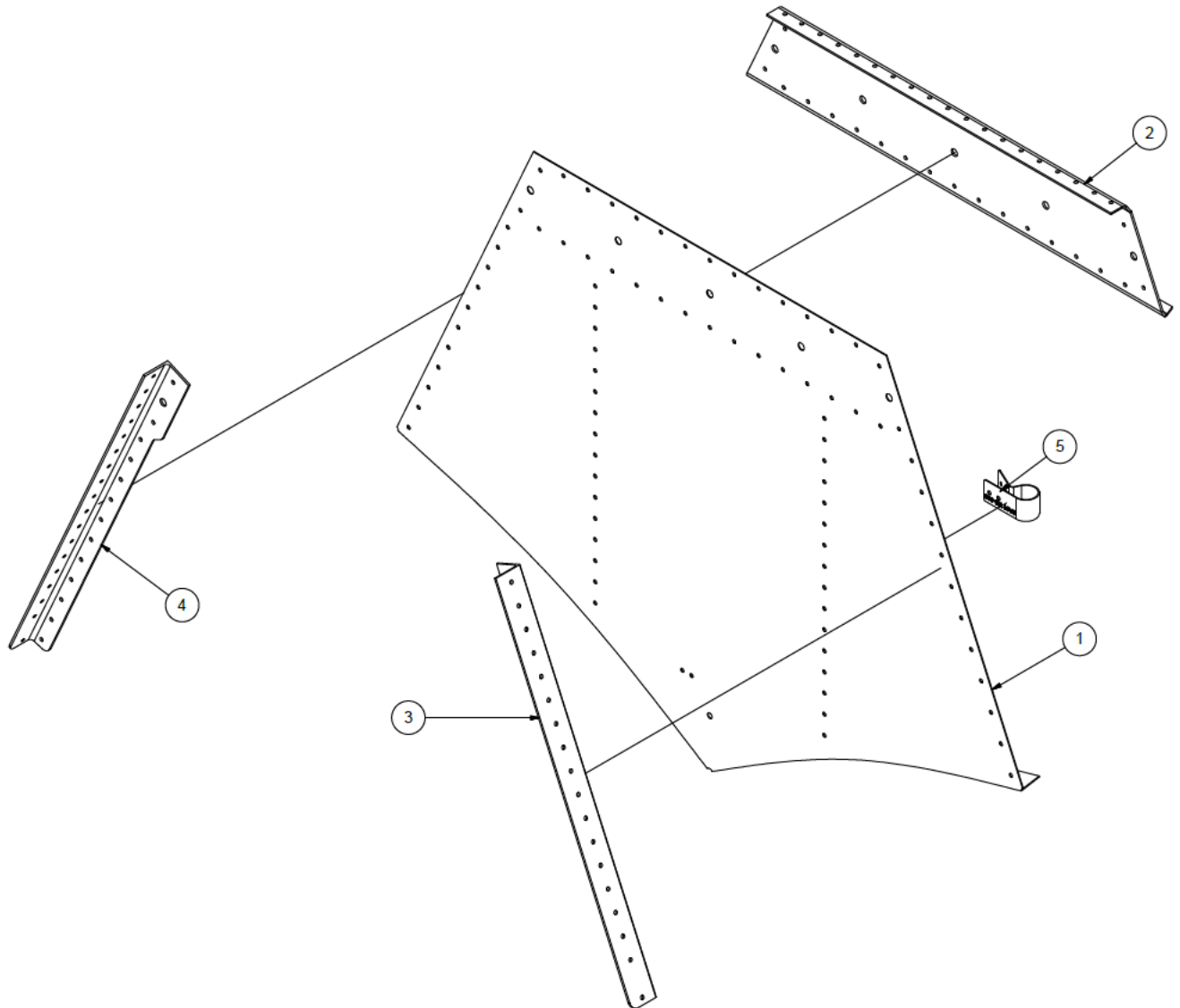

ITEM	QTY	PART NO.	PART DESCRIPTION
-	1	21A01000-262	ASSY, BLKHD 10
1	1	21A01158-169	BULKHEAD #10 - FORMED
2	1	21A01163-066	SPREADER BAR PANEL
3	1	21A01326-011	ANGLE, SIDE BAR, BULKHEAD #10, LF
4	1	21A01326-012	ANGLE, SIDE BAR, BULKHEAD #10, RT
5	1	3A01158-003	CLAMP, PUMP OUT TUBE

BULKHEAD #11

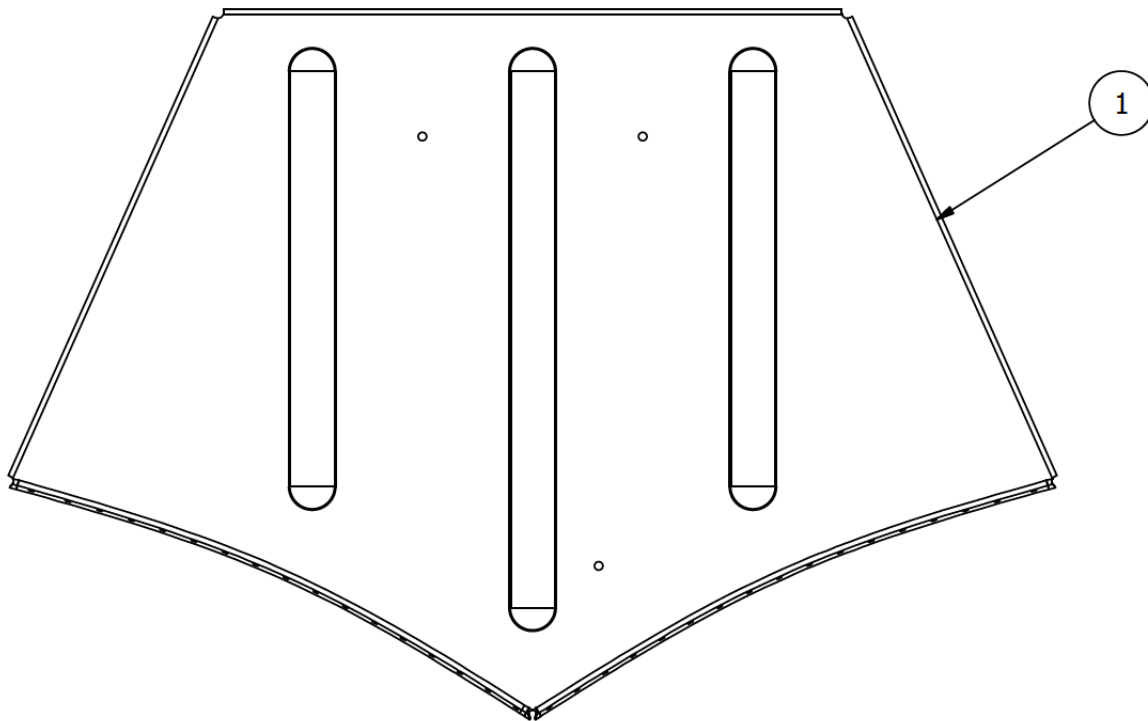

ITEM	QTY	PART NO.	PART DESCRIPTION
-	1	21A01000-395	BULKHEAD STN. #11 ASSY
1	1	21A01158-168	BULKHEAD #11 - FORMED

BULKHEAD #12

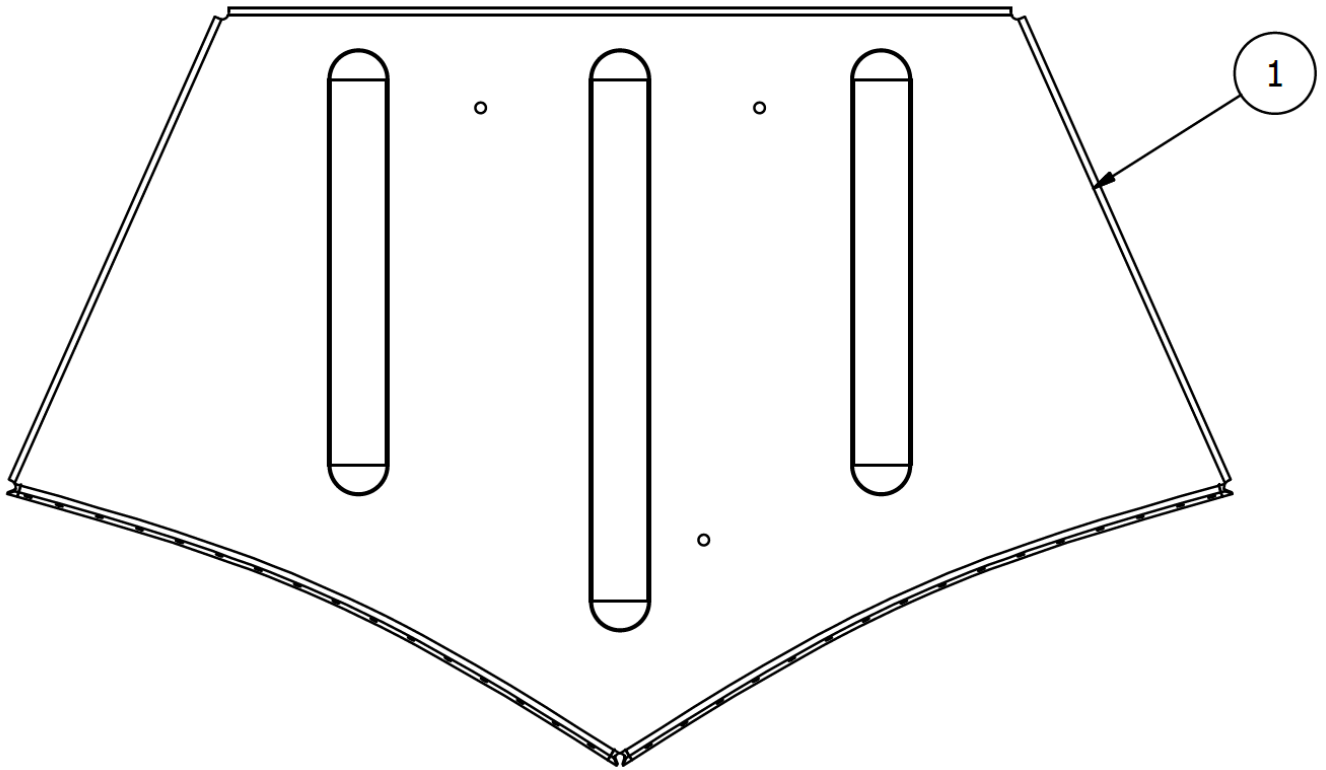

ITEM	QTY	PART NO.	PART DESCRIPTION
-	1	21A01000-396	ASSY, BULKHEAD #12
1	1	21A01158-167	BULKHEAD #12 - FORMED

BULKHEAD #13

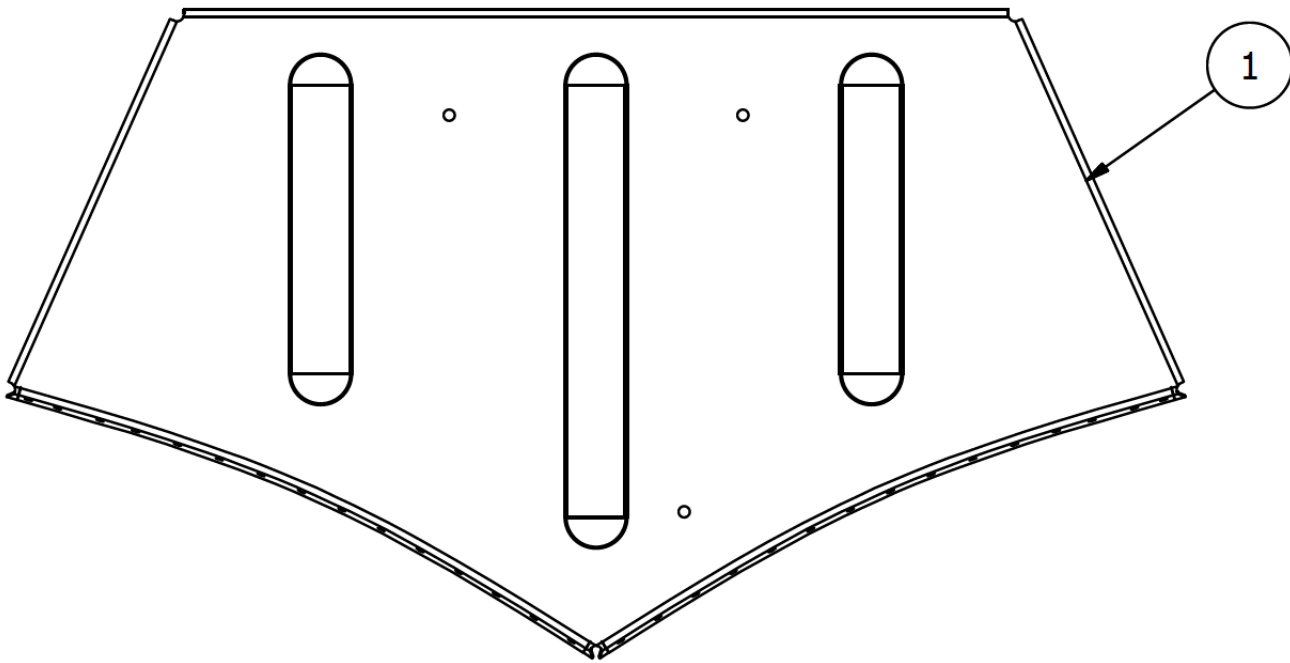

ITEM	QTY	PART NO.	PART DESCRIPTION
-	1	21A01000-397	ASSEMBLY, BULKHEAD #13
1	1	21A01158-166	BULKHEAD #13 - FORMED

BULKHEAD #14

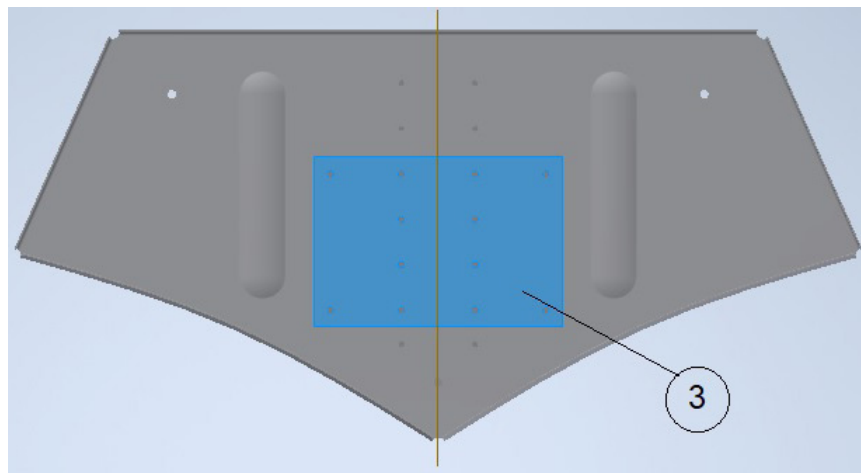
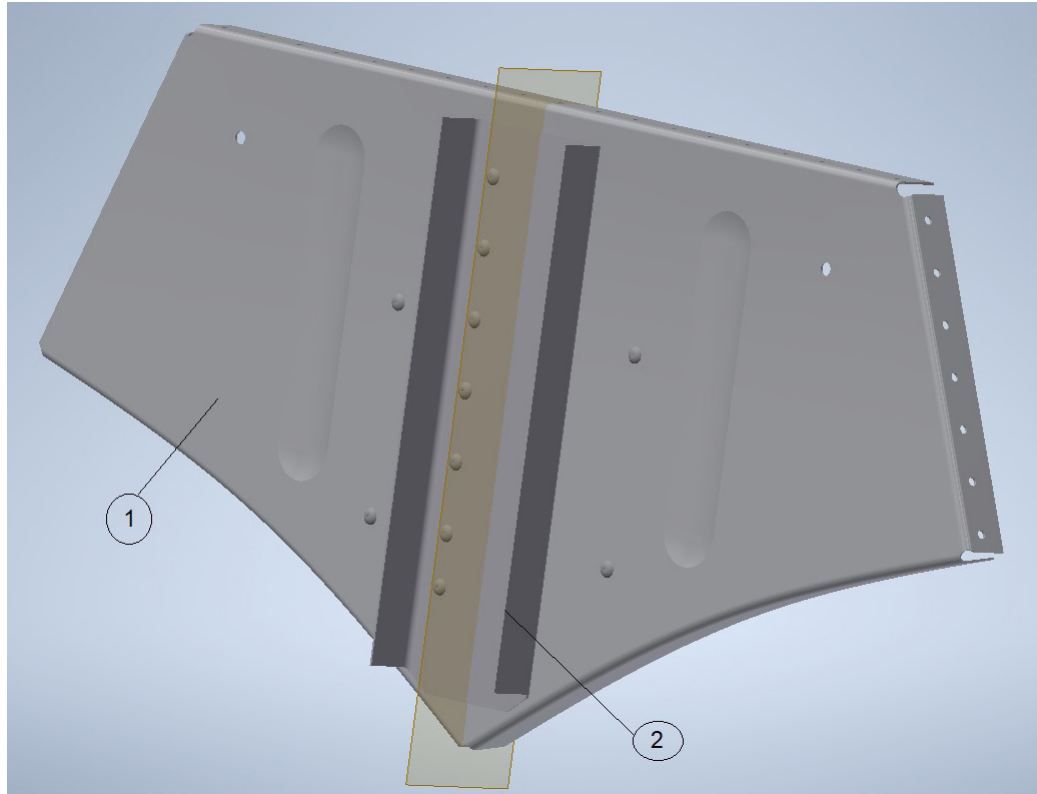

ITEM	QTY	PART NO.	PART DESCRIPTION
-	1	21A01000-250	BULKHEAD STN. #14 ASSY.
1	1	21A01158-164	BULKHEAD STN. #14 FORMED
2	1	21A01158-165	CHANNEL-BULKHEAD #14
3	1	21A08156-130	PLATE-WATER RUDDER STOP

THIS PAGE INTENTIONALLY LEFT BLANK

SECTION 2 WHEEL WELL ASSEMBLY

CONTENTS

WHEEL WELL ASSEMBLY - AMPHIBIAN.....	32
--------------------------------------	----

WHEEL WELL ASSEMBLY - AMPHIBIAN

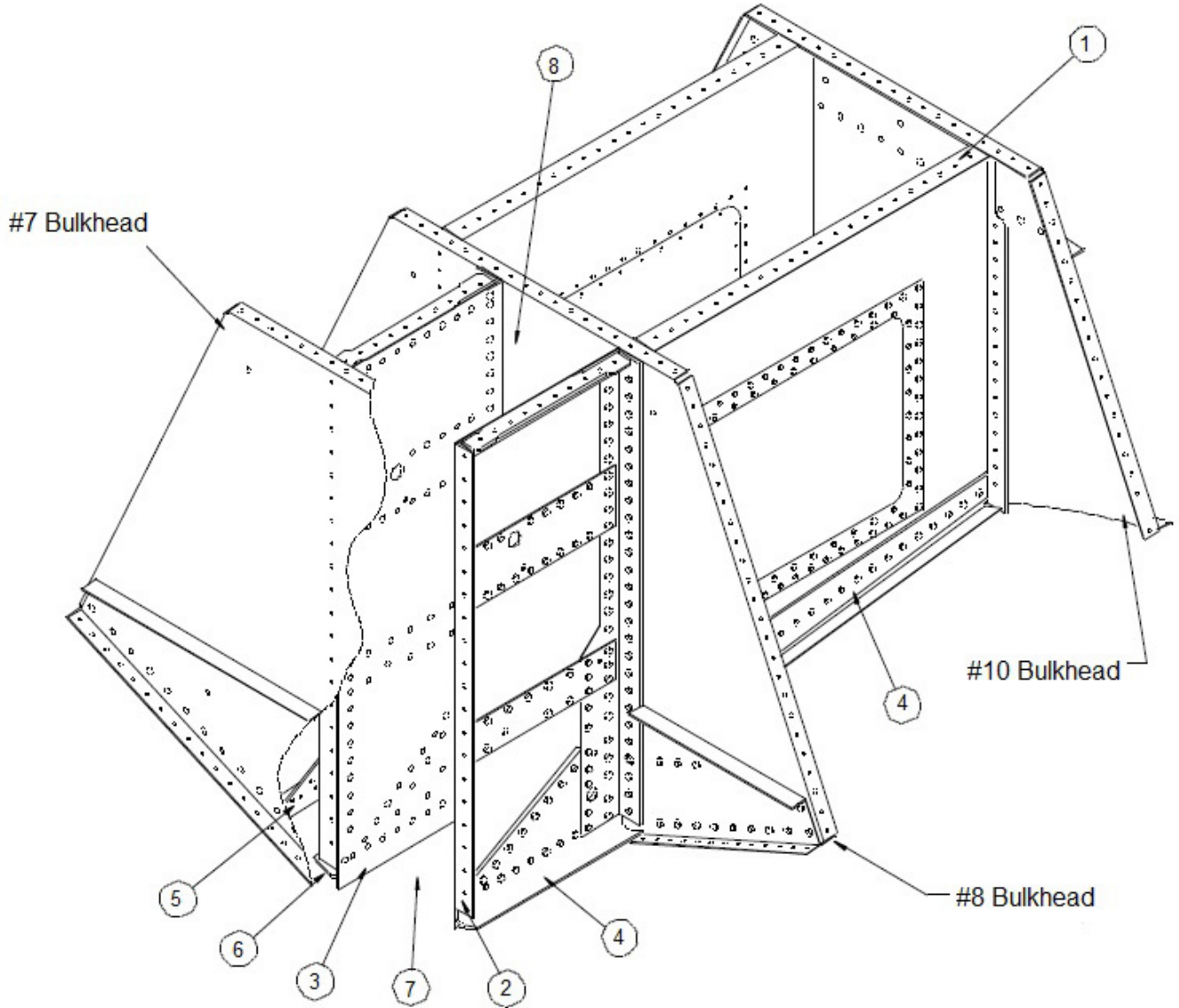

PARTS MANUAL
2100 FLOATS ON CESSNA 172 & 175

ITEM	QTY	PART NO.	PART DESCRIPTION
1	1	21A01000-289	ASSY. – WHEEL WELL HALF L.
	1	21A01158-185	PANEL – FORMED L.
	1	13A01156-124	RING – COVER REINFORCEMENT
	1	21A01158-163	COVER, INSPECTION, WHEELWELL, LARGE
	28	AN526-632R6	SCREW TRUSS HEAD, NON STRUCTURAL CAD 1
	1	21A01000-290	ASSY. – WHEELWELL HALF R.
	1	21A01158-186	PANEL – FORMED R.
	1	13A01156-124	RING – COVER REINFORCEMENT
	1	21A01158-163	COVER, INSPECTION, WHEELWELL, LARGE
	28	AN526-632R6	SCREW TRUSS HEAD, NON STRUCTURAL CAD 1
2	1	21A01000-257	ASSY. – WHEEL WELL PANEL – OUTBR'D L.
	1	21A01000-256	ASSY. - WHEEL WELL PANEL – OUTBR'D R.
3	1	21A01000-255	ASSY. – WHEEL WELL PANEL – INBR'D L.
	1	21A01000-254	ASSY. - WHEEL WELL PANEL – INBR'D R.
4	1	21A01017-005	CARRY-THRU STRAP OUTBR'D L.
	1	21A01017-004	CARRY-THRU STRAP OUTBR'D R.
5	1	21A01017-003	CARRY-THRU STRAP INBR'D L.
	1	21A01017-002	CARRY-THRU STRAP INBR'D R.
6	1	21A01017-007	CARRY-THRU STRAP INBR'D L.
	1	21A01017-006	CARRY-THRU STRAP INBR'D R.
	1	21A01156-131	ANGLE – ATTACH AFT L.
	1	21A01156-132	ANGLE – ATTACH AFT R.
	1	21A01156-125	SPACER, CARRY THRU STRAP
	2	21A01326-015	ANGLE – ATTACH FWD
7	1	21A01000-398	SAND GUARD ASSY. (NOT SHOWN)
	1	21A01150-136	SAND GUARD (NOT SHOWN)
	4	AN526-1032R8	SCREW, TRUSS HEAD, NON STRUCTURAL, CAD 1, STEEL
	4	MS21078-3	NUT PLATE
8	1	21A01569-001	MUD FLAP (NOT SHOWN)
	1	21A01150-135	REINFORCEMENT

THIS PAGE INTENTIONALLY LEFT BLANK

SECTION 3 SKINS & STIFFENERS

CONTENTS

SKINS & STIFFENERS - AMPHIBIAN.....	36
SKINS & STIFFENERS - SEAPLANE	39
BOTTOM SKIN ASSEMBLIES	42
LEFT BOTTOM SKIN & STIFFENERS.....	43
RIGHT BOTTOM SKIN & STIFFENERS	44

SKINS & STIFFENERS - AMPHIBIAN

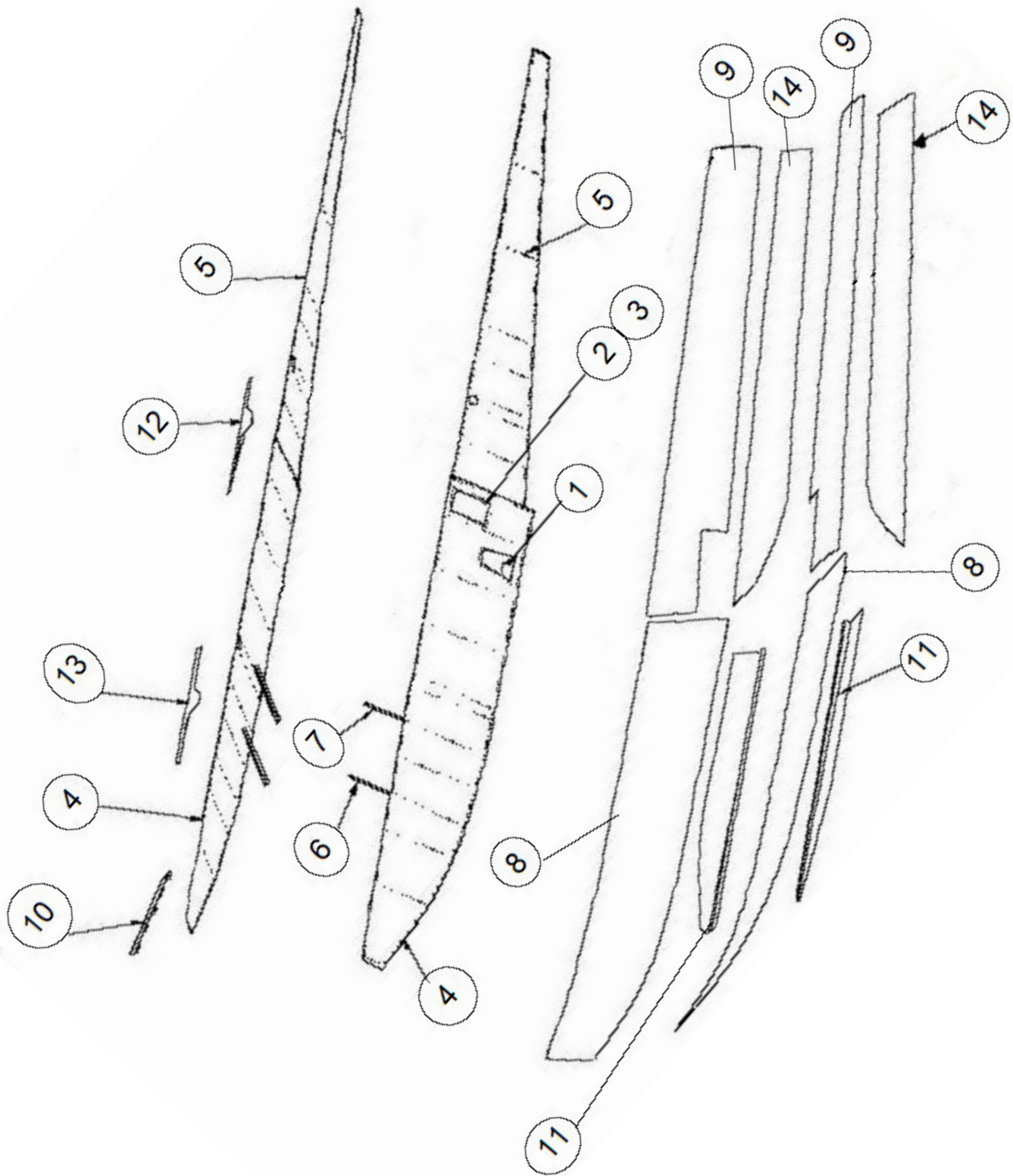

PARTS MANUAL
2100 FLOATS ON CESSNA 172 & 175

ITEM	QTY	PART NO.	PART DESCRIPTION
1	1	3A01000-005	STEP – BOARDING
2	2	21A01156-126	REINFORCEMENT – COVER
3	2	21A01000-427	CONVER – INSP. ASSY.
	2	21A01004-101	COVER – INSP.
	2	21A01567-012	GASKET
	56	AN526-632R6	SCREW TRUSS HEAD, NON STRUCTURAL CAD 1
4	1	21A01004-093	SIDE SKIN – STEP TO BOW L. OUTBR'D
	1	21A01004-094	SIDE SKIN – STEP TO BOW R. OUTBR'D
	1	21A01004-095	SIDE SKIN – STEP TO BOW L. INBR'D
	1	21A01004-096	SIDE SKIN – STEP TO BOW R. INBR'D
	1	1002114	BRACKET (PADDLE)
	1	1002113	STOP (RIGHT)
	1	3A01503-001	CLIP, PADDLE
	1	0238-0035	PADDLE 4 FT.
5	1	21A01004-097	SIDE SKIN – STEP TO STERN L. OUTBR'D
	1	21A01004-098	SIDE SKIN – STEP TO STERN R. OUTBR'D
	1	21A01004-099	SIDE SKIN – STEP TO STERN L. INBR'D
	1	21A01004-100	SIDE SKIN – STEP TO STERN R. INBR'D
6	2	21A01340-105	STIFFENER – SIDE SKIN
7	2	21A01340-104	STIFFENER – SIDE SKIN
8	1	1011430	ASSEMBLY, SKIN, BOTTOM, FWD, LEFT, 2100
	1	1011410	SKIN, BOTTOM, LH, FWD 2100
	1	1011412	STIFFENER, BOTTOM SKIN, FWD
	1	1011413	STIFFENER, BOTTOM SKIN, FWD
	1	1011414	STIFFENER, BOTTOM SKIN, FWD
	1	1011416	STIFFENER, BOTTOM SKIN, FWD
	1	1011418	STIFFENER, BOTTOM SKIN, FWD
	3	1011420	STIFFENER, BOTTOM SKIN, FWD
	1	1011431	ASSEMBLY, SKIN, BOTTOM, FWD, RIGHT, 2100
	1	1011411	SKIN, BOTTOM, RH, FWD, 2100
	1	1011412	STIFFENER, BOTTOM SKIN, FWD
	1	1011413	STIFFENER, BOTTOM SKIN, FWD
	1	1011415	STIFFENER, BOTTOM SKIN, FWD
	1	1011417	STIFFENER, BOTTOM SKIN, FWD
	1	1011419	STIFFENER, BOTTOM SKIN, FWD
	3	1011421	STIFFENER, BOTTOM SKIN, FWD
9	1	21A01004-103	BOTTOM SKIN AFTERBODY L.
	1	21A01004-104	BOTTOM SKIN AFTERBODY R.
10	1	21A01000-275	ASSY. SPRAY RAIL R.
	1	21A01000-274	ASSY. SPRAY RAIL L.
11	1	21A01000-429	BOOSTER – SISTER KEEL L.

ITEM	QTY	PART NO.	PART DESCRIPTION
	1	21A01000-428	BOOSTER – SISTER KEEL R.
12	1	21A01162-033	DOUBLER – GUNWALL AFT L.
	1	21A01162-034	DOUBLER – GUNWALL AFT R.
13	1	21A01162-031	DOUBLER – GUNWALL FWD L.
	1	21A01162-032	DOUBLER – GUNWALL FWD R.
14	1	1009422	SCALLOP, FOAM, RIGHT, 2100 S/N 21977 AND LATER
	1	1009424	SCALLOP, FOAM, LEFT, 2100 S/N 21977 AND LATER

SKINS & STIFFENERS - SEAPLANE

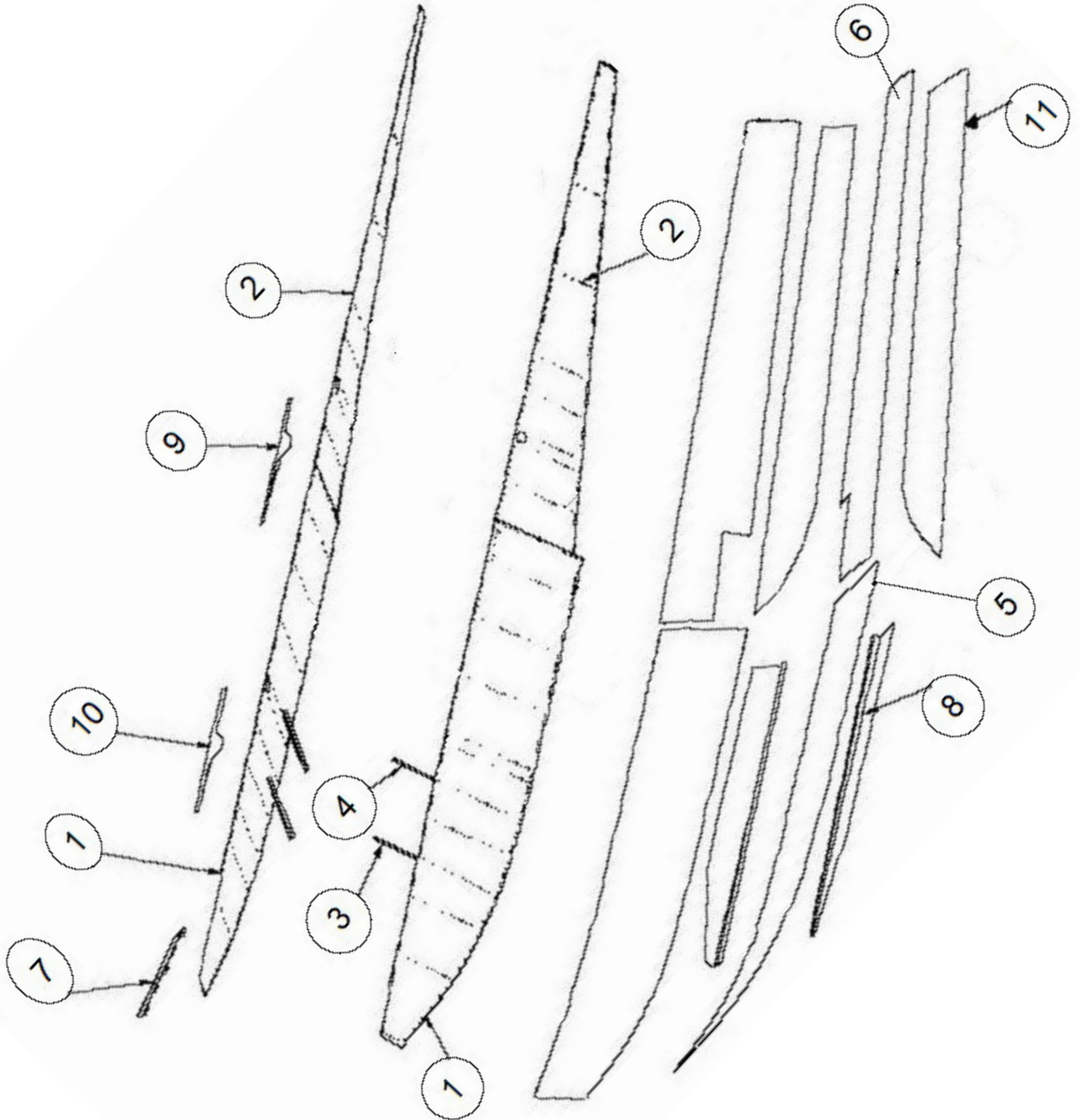

ITEM	QTY	PART NO.	PART DESCRIPTION
1	1	21S01004-123	SIDE SKIN – STEP TO BOW L. OUTBR'D
	1	21S01004-122	SIDE SKIN – STEP TO BOW R. OUTBR'D
	1	21S01004-125	SIDE SKIN – STEP TO BOW L. INBR'D
	1	21S01004-124	SIDE SKIN – STEP TO BOW R. INBR'D
	1	1002114	BRACKET (PADDLE)
	1	3A01156-057	STOP (LEFT)
	1	1002113	STOP (RIGHT)
	1	3A01503-001	CLIP, PADDLE
	1	0238-0035	PADDLE
2	1	21A01004-097	SIDE SKIN – STEP TO STERN L. OUTBR'D
	1	21A01004-098	SIDE SKIN – STEP TO STERN R. OUTBR'D
	1	21A01004-099	SIDE SKIN – STEP TO STERN L. INBR'D
	1	21A01004-100	SIDE SKIN – STEP TO STERN R. INBR'D
3	2	21A01340-105	STIFFENER – SIDE SKIN
4	2	21A01340-104	STIFFENER – SIDE SKIN
5	1	1011430	ASSEMBLY, SKIN, BOTTOM, FWD, LEFT, 2100
	1	1011410	SKIN, BOTTOM, LH, FWD 2100
	1	1011412	STIFFENER, BOTTOM SKIN, FWD
	1	1011413	STIFFENER, BOTTOM SKIN, FWD
	1	1011414	STIFFENER, BOTTOM SKIN, FWD
	1	1011416	STIFFENER, BOTTOM SKIN, FWD
	1	1011418	STIFFENER, BOTTOM SKIN, FWD
	3	1011420	STIFFENER, BOTTOM SKIN, FWD
	1	1011431	ASSEMBLY, SKIN, BOTTOM, FWD, RIGHT, 2100
	1	1011411	SKIN, BOTTOM, RH, FWD, 2100
	1	1011412	STIFFENER, BOTTOM SKIN, FWD
	1	1011413	STIFFENER, BOTTOM SKIN, FWD
	1	1011415	STIFFENER, BOTTOM SKIN, FWD
	1	1011417	STIFFENER, BOTTOM SKIN, FWD
	1	1011419	STIFFENER, BOTTOM SKIN, FWD
	3	1011421	STIFFENER, BOTTOM SKIN, FWD
6	1	21S01004-131	BOTTOM SKIN AFTERBODY L.
	1	21S01004-130	BOTTOM SKIN AFTERBODY R.
7	1	21A01000-275	ASSY. SPRAY RAIL R.
	1	21A01000-274	ASSY. SPRAY RAIL L.
8	1	21A01000-429	BOOSTER – SISTER KEEL L.
	1	21A01000-428	BOOSTER – SISTER KEEL R.
9	1	21A01162-033	DOUBLER – GUNWALL AFT L.
	1	21A01162-034	DOUBLER – GUNWALL AFT R.
10	1	21A01162-031	DOUBLER – GUNWALL FWD L.
	1	21A01162-032	DOUBLER – GUNWALL FWD R.

PARTS MANUAL
2100 FLOATS ON CESSNA 172 & 175

ITEM	QTY	PART NO.	PART DESCRIPTION
11	1	1009422	SCALLOP, FOAM, RIGHT, 2100 S/N 21977 AND LATER
	1	1009424	SCALLOP, FOAM, LEFT, 2100 S/N 21977 AND LATER

BOTTOM SKIN ASSEMBLIES

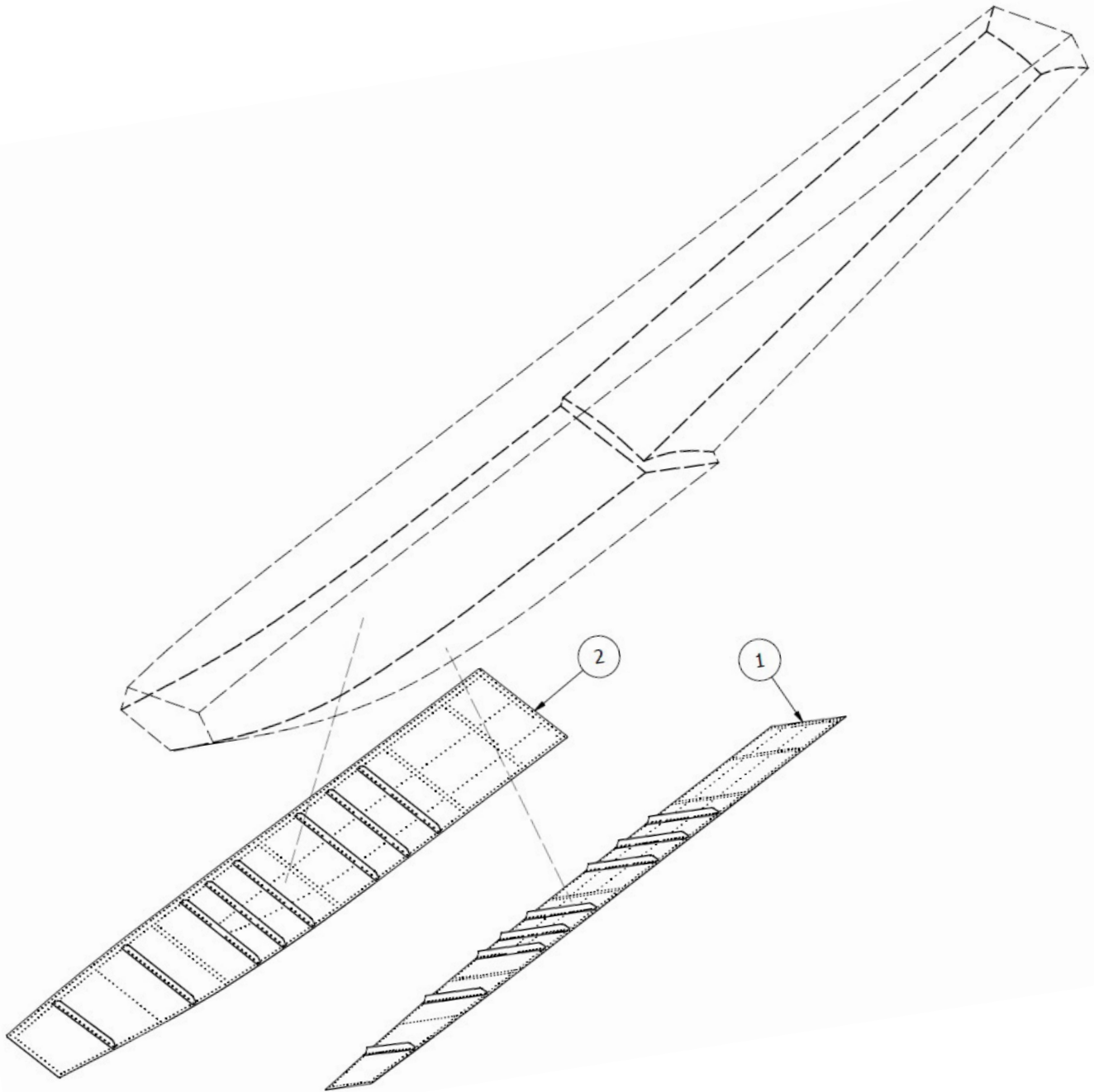

ITEM	QTY	PART NO.	PART DESCRIPTION
1	1	1011430	ASSEMBLY, SKIN, BOTTOM, FWD, LEFT, 2100
2	1	1011431	ASSEMBLY, SKIN, BOTTOM, FWD, RIGHT, 2100

LEFT BOTTOM SKIN & STIFFENERS

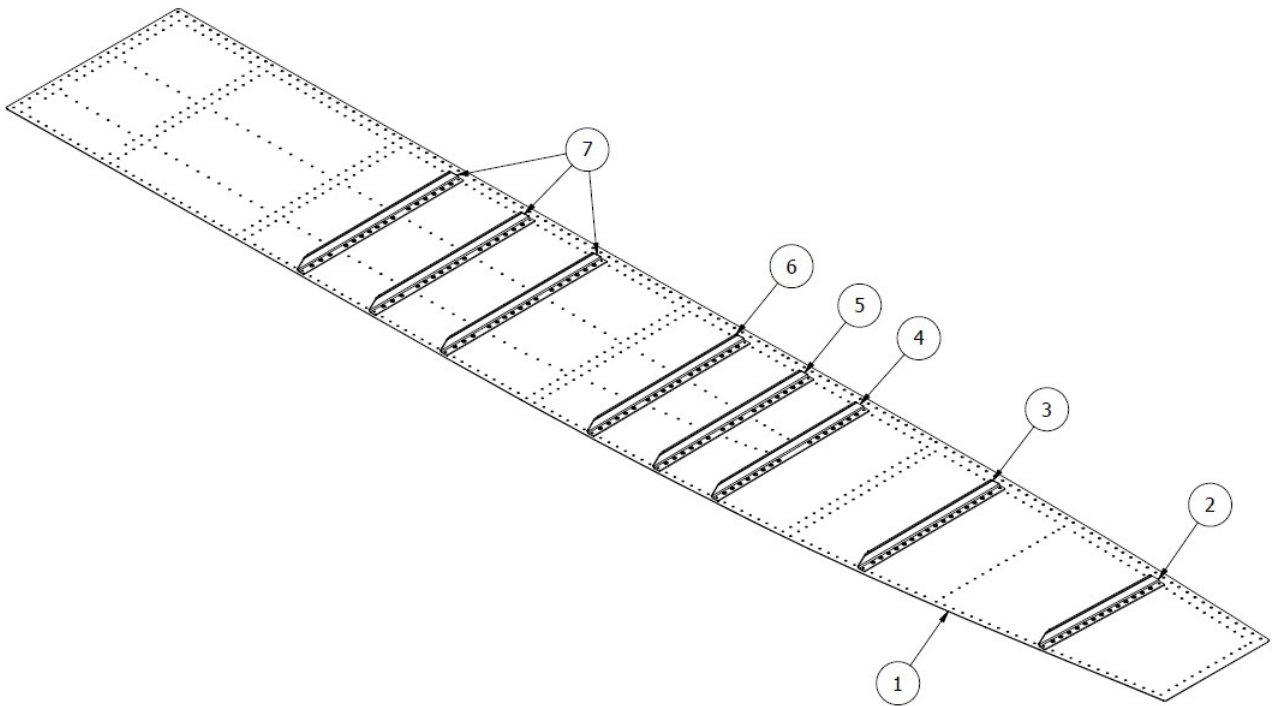

ITEM	QTY	PART NO.	PART DESCRIPTION
1	1	1011410	SKIN, BOTTOM, LH, FWD 2100
2	1	1011412	STIFFENER, BOTTOM SKIN, FWD
3	1	1011413	STIFFENER, BOTTOM SKIN, FWD
4	1	1011414	STIFFENER, BOTTOM SKIN, FWD
5	1	1011416	STIFFENER, BOTTOM SKIN, FWD
6	1	1011418	STIFFENER, BOTTOM SKIN, FWD
7	3	1011420	STIFFENER, BOTTOM SKIN, FWD

RIGHT BOTTOM SKIN & STIFFENERS

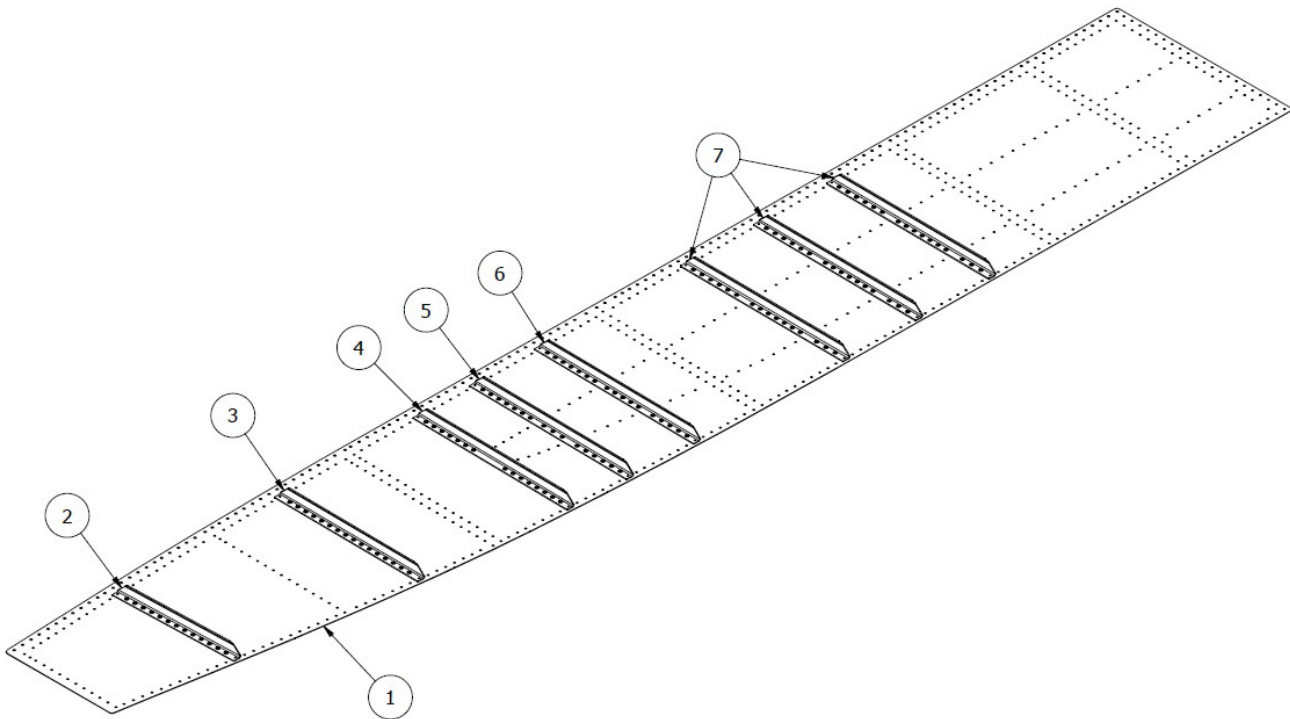

ITEM	QTY	PART NO.	PART DESCRIPTION
1	1	1011411	SKIN, BOTTOM, RH, FWD, 2100
2	1	1011412	STIFFENER, BOTTOM SKIN, FWD
3	1	1011413	STIFFENER, BOTTOM SKIN, FWD
4	1	1011415	STIFFENER, BOTTOM SKIN, FWD
5	1	1011417	STIFFENER, BOTTOM SKIN, FWD
6	1	1011419	STIFFENER, BOTTOM SKIN, FWD
7	3	1011421	STIFFENER, BOTTOM SKIN, FWD

SECTION 4 TOP DECK ASSEMBLY

CONTENTS

TOP DECK - AMPHIBIAN	46
TOP DECK - SEAPLANE.....	49

TOP DECK - AMPHIBIAN

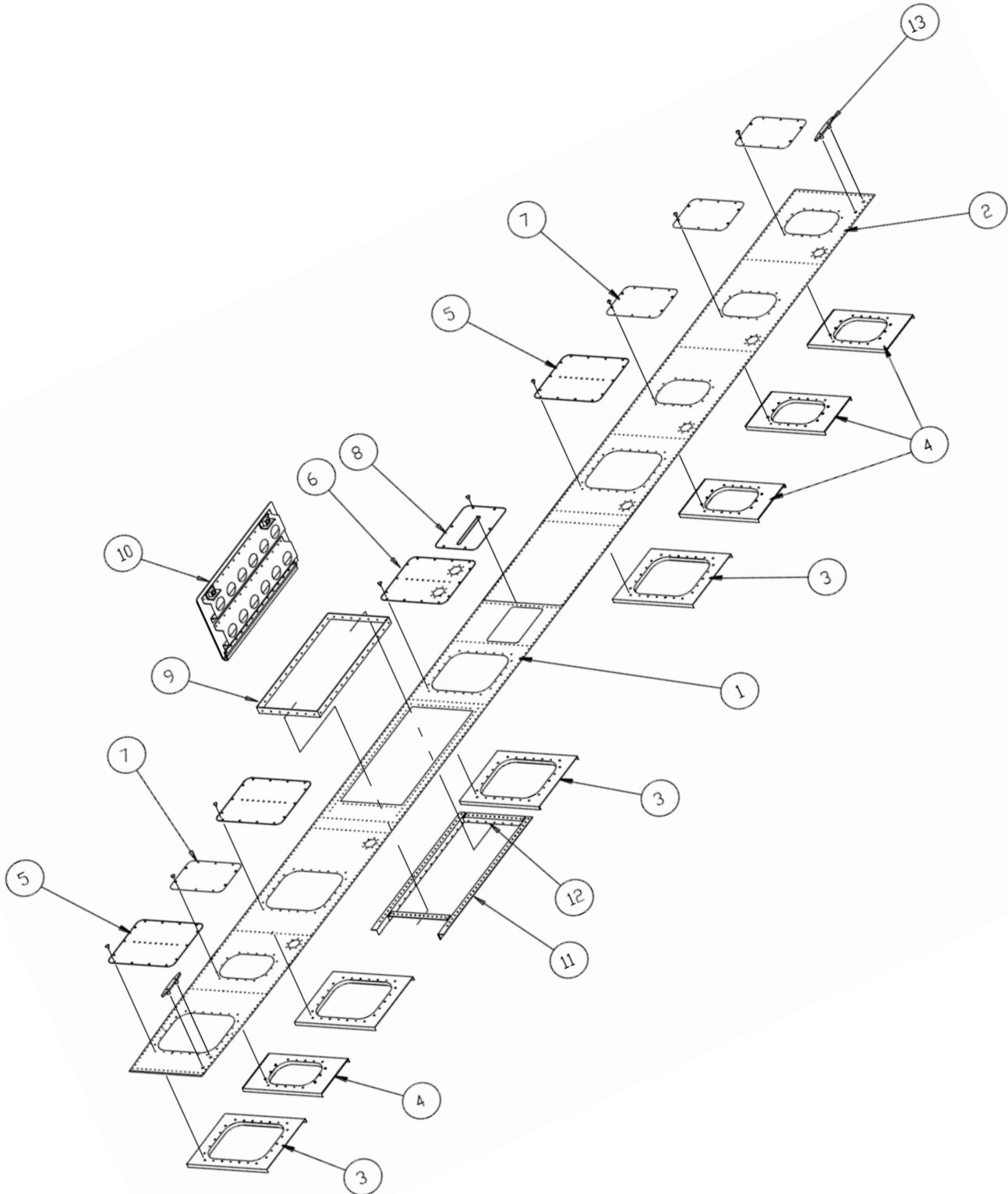

PARTS MANUAL
2100 FLOATS ON CESSNA 172 & 175

ITEM	QTY	PART NO.	PART DESCRIPTION
1	1	21A01004-091	SKIN – FWD SECTION L.
	1	21A01004-092	SKIN – FWD SECTION R.
2	1	21A01004-089	SKIN – AFT SECTION L.
	1	21A01004-090	SKIN – AFT SECTION R.
3	4	21A01002-130	SUPPORT – INSP. COVER - LARGE
	A/R	1002481	TINNERMAN WITH TAPE
4	4	21A01002-131	SUPPORT – INSP. COVER – SMALL
	A/R	1002481	TINNERMAN WITH TAPE
5	3	21A01000-258	INSP. COVER ASSY– LARGE – W/ ANGLE & GASKET
	A/R	SS TATP 8 X 5/8	SCREW – ATTACH
	3	1001437	SEAL – GASKET ONLY (FORMED COVER)
	3	21A01567-001	SEAL – GASKET ONLY (FLAT COVER)
6	1	21A01000-273	INSP. COVER ASSY, LARGE, W/ ANGLE (2 CUPS) & GASKET
	A/R	SS TATP 8 X 5/8	SCREW – ATTACH
	3	1001437	SEAL – GASKET ONLY (FORMED COVER)
	3	21A01567-001	SEAL – GASKET ONLY (FLAT COVER)
7	4	21A01000-284	INSP. COVER ASSY - SMALL
	A/R	SS TATP 8 X 5/8	SCREW – ATTACH
	3	1001437	SEAL – GASKET ONLY (FORMED COVER)
	3	21A01567-002	SEAL – GASKET ONLY (FLAT COVER)
8	1	21A01002-137	COVER – GEAR INDICATOR L.
	1	21A01002-138	COVER – GEAR INDICATOR R.
	1	10A3-6338-1	PLACARD – DOWN - LAND
	1	10A3-6338-2	PLACARD – UP - WATER
	4	2600-3	SCREW – CAM - LOK
	2	1126000-5	SCREW – CAM – LOK
	6	212-12N	RECEPTACLE – CAM – LOK
9	1	21A01150-131	JAMB – BAGGAGE DOOR
	1	1002067	BAGGAGE JAMB, HINGE SIDE
10	1	21A01000-268	ASSY – BAGGAGE DOOR
	1	21A01162-035	COVER - SKIN
	1	21A01740-008	HINGE, BAGGAGE COVER, 1.5
	1	21A01741-004	HINGE, BAGGAGE COVER, 3/4
	2	21A01010-012	STIFFENER - DOOR
	2	21A01004-106	STIFFENER ENDS
	2	3A01206-001	RETAINER - LOCK
	2	3A01273-004	LOCK PIN
	2	3A01702-001	CATCH – LATCH
	2	3A01525-003	LOCK SPRING
	2	1002663	RING – OPENING
	1	1001438	SEAL – GASKET (NOT SHOWN)

ITEM	QTY	PART NO.	PART DESCRIPTION
	1	1002186	HINGE PIN
	12	01692-0410	RIVET POP
	2	10/32 X ½ SS	BOLT
11	1	21A01326-003	TOP RAIL – BAGGAGE OPENING L.
	1	21A01326-002	TOP RAIL – BAGGAGE OPENING R.
12	2	21A01326-004	JAMB – BAGGAGE DOOR
13	2	21A01203-001	CLEAT – TIE DOWN
	4	21A01280-004	BUSHING
	4	AN525-10R24	SCREW, HEAD, 10-32 THREAD, 1-3/32" GRIP, 1-1/2" LENGTH
	4	MS21044N3	NUT, LOCKING, REGULAR HEIGHT, 10-32 UNF
	4	NAS1149D0363J	WASHER, 0.203 ID, 0.063 THK, ALUMINUM

TOP DECK - SEAPLANE

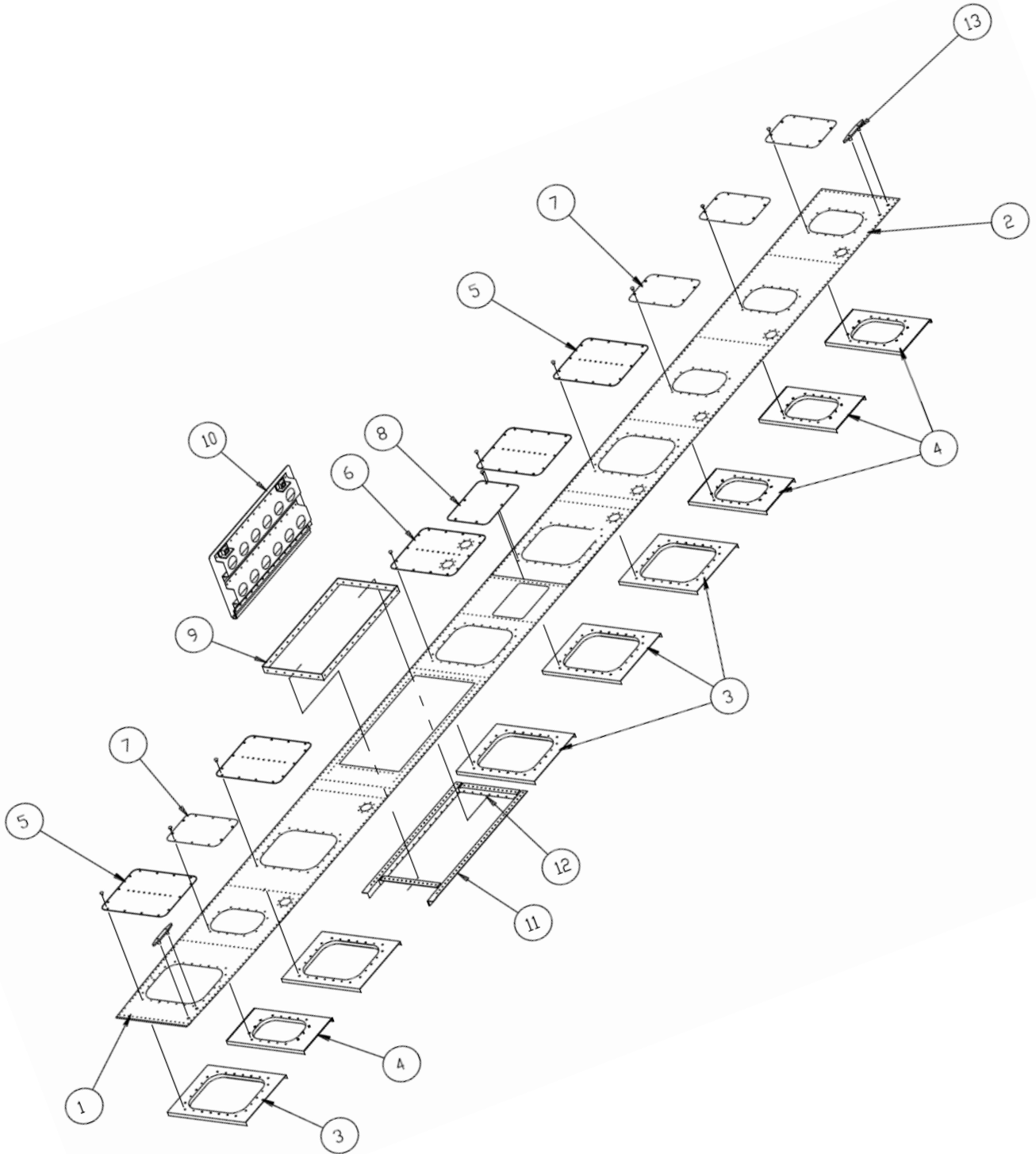

ITEM	QTY	PART NO.	PART DESCRIPTION
1	1	21S01004-135	SKIN – FWD SECTION L.
	1	21S01004-134	SKIN – FWD SECTION R.
2	1	21S01004-137	SKIN – AFT SECTION L.
	1	21S01004-136	SKIN – AFT SECTION R.
3	4	21A01002-130	SUPPORT – INSP. COVER - LARGE
	A/R	1002481	TINNERMAN WITH TAPE
4	5	21A01002-131	SUPPORT – INSP. COVER – SMALL
	A/R	1002481	TINNERMAN WITH TAPE
5	4	21A01000-258	INSP. COVER ASSY – LARGE – W/ ANGLE & GASKET
	A/R	SS TATP 8 X 5/8	SCREW – ATTACH
	3	1001437	SEAL – GASKET ONLY (FORMED COVER)
	3	21A01567-001	SEAL – GASKET ONLY (FLAT COVER)
6	1	2A01000-273	INSP. COVER – LARGE – ANGLE (2 CUPS) & GASKET
	A/R	SS TATP 8 X 5/8	SCREW – ATTACH
	3	1001437	SEAL – GASKET ONLY (FORMED COVER)
	3	21A01567-001	SEAL – GASKET ONLY (FLAT COVER)
7	4	21A01000-284	INSP. COVER ASSY- SMALL & GASKET
	A/R	SS TATP 8 X 5/8	SCREW – ATTACH
	4	1001728	SEAL – GASKET ONLY (FORMED COVER)
	3	21A01567-002	SEAL – GASKET ONLY (FLAT COVER)
8	1	21S01000-399	COVER ASSY & GASKET
	1	1002110	SEAL – GASKET ONLY
	A/R	SS TATP 8 X 5/8	SCREW – ATTACH
	A/R	9A3-671	NUT – TINNERMAN
	2	30S01326-035	STIFFENER – ANGLE
9	1	21A01150-131	JAMB – BAGGAGE DOOR
	1	101438	SEAL – GASKET (NOT SHOWN)
	1	1002067	JAMB – HINGE SIDE
10	1	21A01000-268	ASSY – BAGGAGE DOOR
	1	21A01162-035	COVER - SKIN
	1	21A01741-004	HINGE, BAGGAGE COVER, 3/4
	2	21A01010-012	STIFFENER - DOOR
	2	21A01004-106	STIFFENER ENDS
	2	3A01206-001	RETAINER - LOCK
	2	3A01273-004	LOCK PIN
	2	3A01702-001	CATCH – LATCH
	2	3A01525-003	LOCK SPRING
	2	9-0177A221	RING – OPENING
	1	101438	SEAL – GASKET (NOT SHOWN)
11	1	21A01326-003	TOP RAIL – BAGGAGE OPENING L.
	1	21A01326-002	TOP RAIL – BAGGAGE OPENING R.

PARTS MANUAL
2100 FLOATS ON CESSNA 172 & 175

ITEM	QTY	PART NO.	PART DESCRIPTION
12	2	21A01326-004	JAMB – BAGGAGE DOOR
13	2	21A01203-001	CLEAT – TIE DOWN
	4	21A01280-004	BUSHING
	4	AN525-10R24	SCREW, HEAD, 10-32 THREAD, 1-3/32" GRIP, 1-1/2" LENGTH
	4	MS21044N3	NUT, LOCKING, REGULAR HEIGHT, 10-32 UNF
	4	NAS1149D0363J	WASHER, 0.203 ID, 0.063 THK, ALUMINUM

THIS PAGE INTENTIONALLY LEFT BLANK

SECTION 5 EXTRUSIONS

CONTENTS

HULL EXTRUSIONS - AMPHIBIAN	54
HULL EXTRUSIONS - SEAPLANE.....	56

HULL EXTRUSIONS - AMPHIBIAN

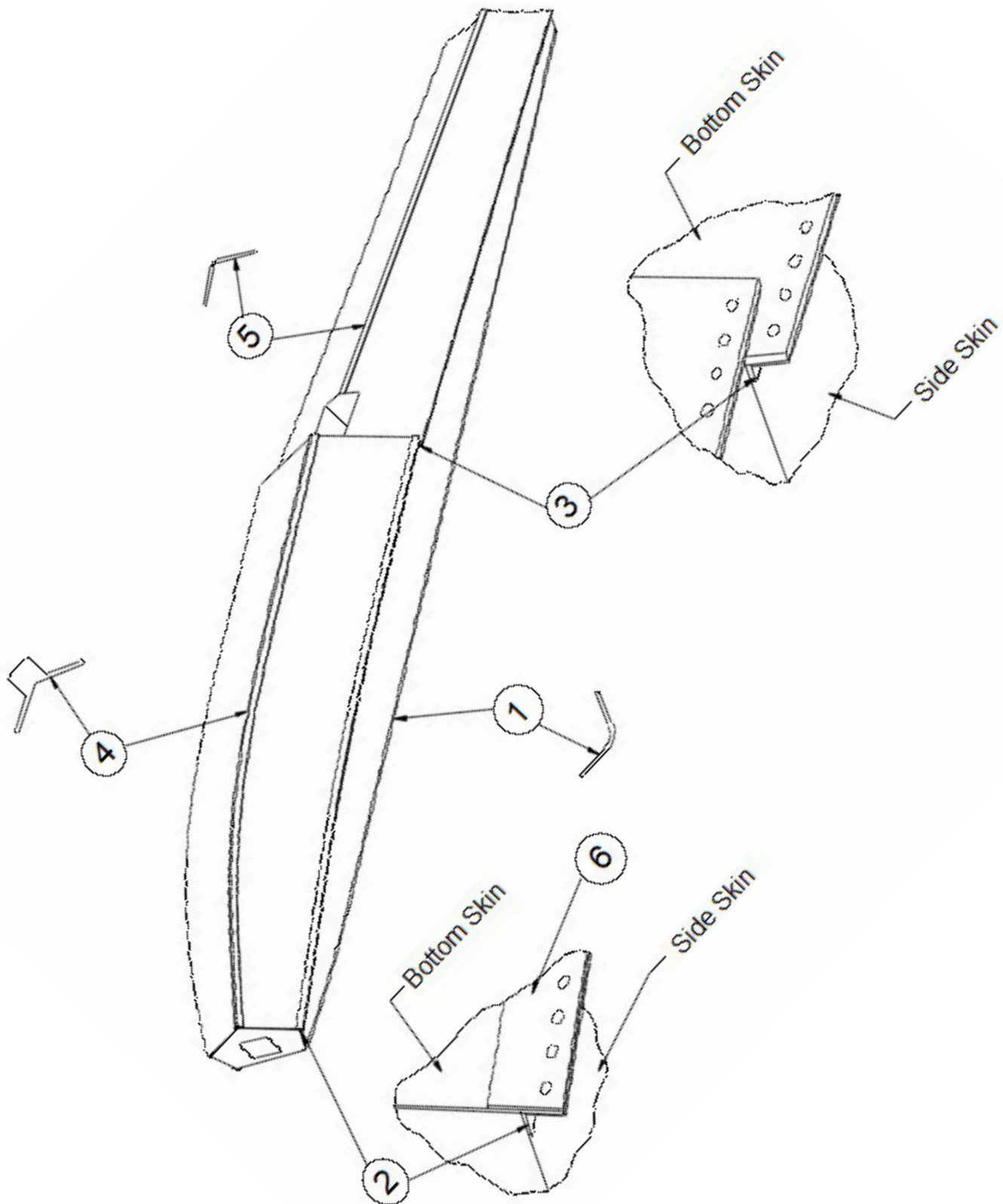

PARTS MANUAL
2100 FLOATS ON CESSNA 172 & 175

ITEM	QTY	PART NO.	PART DESCRIPTION
1	1	21A01324-001	GUNWALL – L.
	1	21A01324-002	GUNWALL – R.
2	1	21A01340-109	CHINE - FWD L.
	1	21A01340-108	CHINE – FWD R.
3	1	21A01340-107	CHINE – AFTERBODY L.
	1	21A01340-106	CHINE – AFTERBODY R.
4	1	21A01321-001	KEEL - MAIN
5	1	21A01008-142	KEEL - AFTERBODY

HULL EXTRUSIONS - SEAPLANE

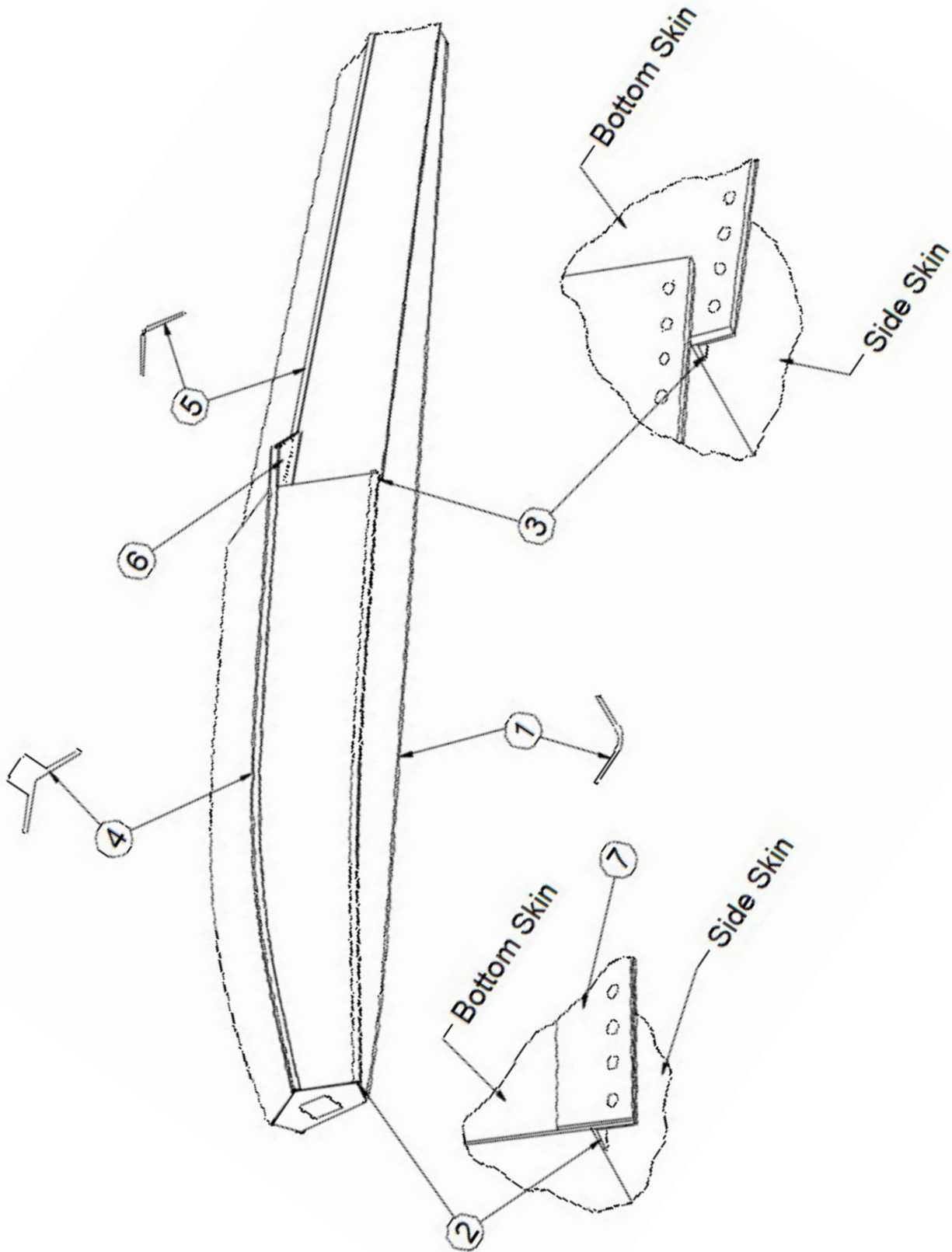

PARTS MANUAL
2100 FLOATS ON CESSNA 172 & 175

ITEM	QTY	PART NO.	PART DESCRIPTION
1	1	21A01324-001	GUNWALL – L.
	1	21A01324-002	GUNWALL – R.
2	1	21A01340-109	CHINE - FWD L.
	1	21A01340-108	CHINE – FWD R.
3	1	21A01340-107	CHINE – AFTERBODY L.
	1	21A01340-106	CHINE – AFTERBODY R.
4	1	21S01321-004	KEEL - MAIN
5	1	21S01008-172	KEEL - AFTERBODY
6	1	21S01000-400	AFTERBODY GUSSET ASSY.
	1	21S01163-037	ANGLE SUPPORT – AFTERBODY L.
	1	21S01163-038	ANGLE SUPPORT – AFTERBODY R.

THIS PAGE INTENTIONALLY LEFT BLANK

SECTION 6 PUMPER TUBE INSTALLATION

CONTENTS

PUMPER TUBE.....	60
------------------	----

PUMPER TUBE

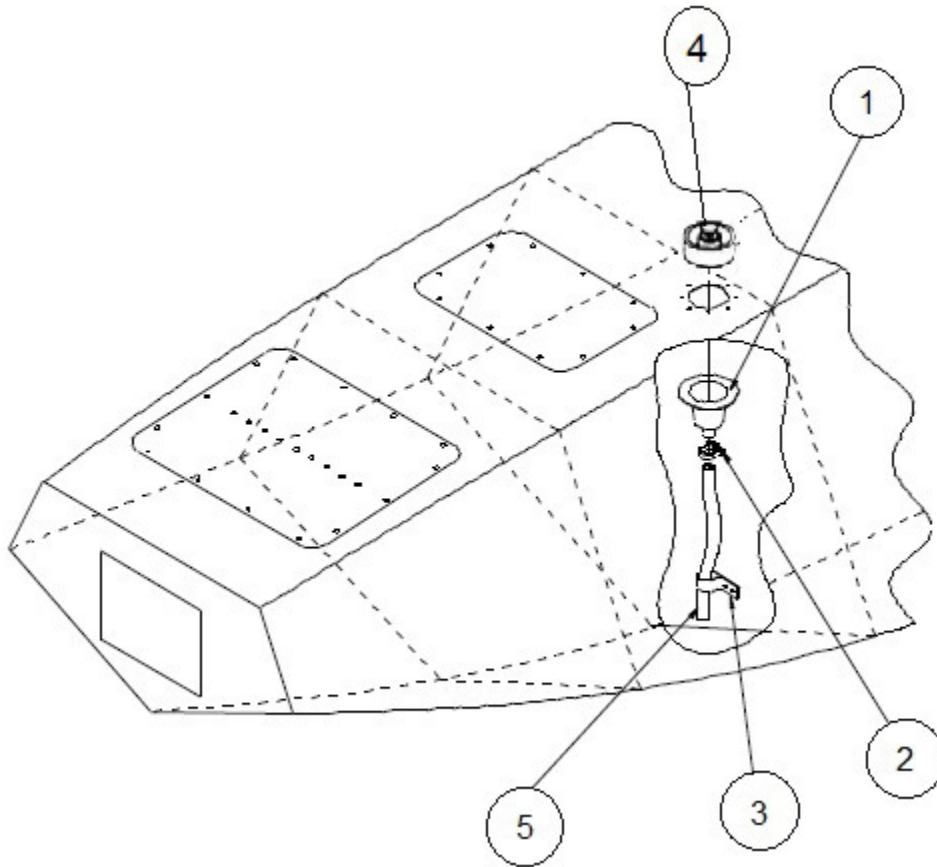

ITEM	QTY	PART NO.	PART DESCRIPTION
1	1	1011004	ASSEMBLY, CUP, PUMPOUT, DUCKBILL
	1	4A01749-001	CUP – PUMPOUT ALUM.
	1	1011808	RETAINER, VALVE, DUCKBILL, PUMPOUT PLUG
2	1	57134	CLAMP – UPPER END
3	1	3A01158-003	CLAMP – LOWER END
4	1	1011870	VALVE, DUCKBILL (NEW VERSION)
	1	2111	STOPPER – PUMPER TUBE
5	1	21A01618-062	PUMPOUT TUBE 10.5 IN.
	1	21A01648-061	PUMPOUT TUBE 12.5 IN.
	1	21A01648-060	PUMPOUT TUBE 15.0 IN.
	1	21A01618-059	PUMPOUT TUBE 17.5 IN.
	1	21A01648-058	PUMPOUT TUBE 23.0 IN.
	1	21A01648-056	PUMPOUT TUBE 21.5 IN.
	1	21A01648-055	PUMPOUT TUBE 18.5 IN.

SECTION 7 WATER RUDDER, RETRACT HANDLE, & STEERING AND RETRACT SYSTEM

CONTENTS

WATER RUDDER INSTALLATION	62
RETRACT HANDLE ASSEMBLY	64
STEERING & RETRACT SYSTEM INSTALLATION	66

WATER RUDDER INSTALLATION

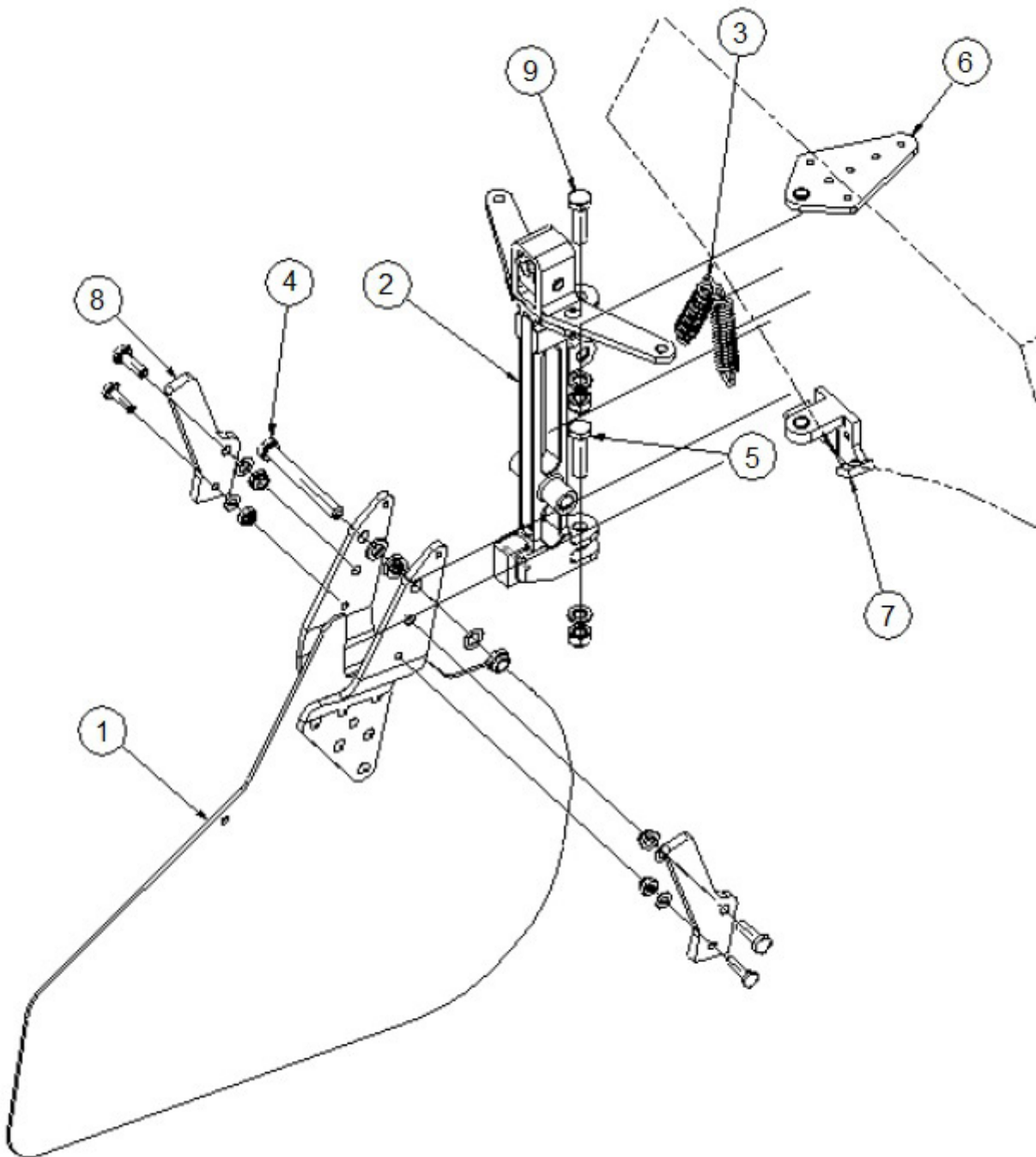

PARTS MANUAL
2100 FLOATS ON CESSNA 172 & 175

ITEM	QTY	PART NO.	PART DESCRIPTION
1	1	21A08000-123	ASSY. - BLADE
	1	1002649	BLADE
	1	21A08019-001	ARM L.
	1	21A08019-002	ARM R.
2	1	1003858	WATER RUDDER POST WITH BELLCRANK ASSEMBLY
	1	1003854	WATER RUDDER POST ASSEMBLY
	1	1003853	BELLCRANK, WATER RUDDER POST ASSEMBLY
	1	21A08648-002	BUMBER, DOWN STOP
	1	1001457	ROLL PIN
	1	21A8602-009	GUIDE, RETRACT
	1	5/16 X 1 1/2 INCHES	PIN ATTACH
3	2	21A08525-006	SPRING
4	1	AN5-25A	BOLT, 5/16-24, 2.1875 GRIP, UNDRILLED, STEEL
	3	NAS1149D0516J	WASHER, 0.328 ID, 0.016 THK, ALUMINUM
	1	NAS 1149D0563J	WASHER, 0.328 ID, 0.063 THK, ALUMINUM
	1	MS21083N5	NUT, LOCKING, LOW HEIGHT, 5/16-24 UNF
5	1	AN5-11A	BOLT, 5/16-24 THREAD, 11/16" GRIP, 1-7/32" LENGTH
	A/R	NAS1149D0563J	WASHER, 0.328 ID, 0.063 THK, ALUMINUM
	1	MS21044N5	NUT, LOCKING, REGULAR HEIGHT, 5/16-24 UNF
6	1	21A01000-299	ASSEMBLY – TOP BEARING
	1	21A01019-003	PLATE
	1	21A01705-003	BEARING
7	1	21A08000-157	ASSEMBLY – LOWER BEARING
	1	21A08318-002	BRACKET
	1	05DU06	BEARING
8	2	21A08154-009	STOP
	2	AN4-6A	BOLT, 1/4-28, 0.3125 GRIP, UNDRILLED, STEEL
	2	NAS1149D0416J	WASHER, 0.265 ID, 0.016 THK, ALUMINUM
	2	MS21083N4	NUT, LOCKING, LOW HEIGHT, 1/4-28 UNF
	2	AN3-6A	BOLT, 10-32, 0.375 GRIP, UNDRILLED, STEEL
	2	NAS1149D0316J	WASHER, 0.203 ID, 0.016 THK, ALUMINUM
	2	MS21044N3	NUT, LOCKING, REGULAR HEIGHT, 10-32 UNF
9	1	AN5-12A	BOLT SIZE 5/16-24, LENGTH 1/64 - 1-11/32, GRIP LENGTH 13/16
	A/R	NAS1149D0563J	WASHER, 0.328 ID, 0.063 THK, ALUMINUM
	1	MS21044N5	NUT, LOCKING, REGULAR HEIGHT, 5/16-24 UNF

RETRACT HANDLE ASSEMBLY

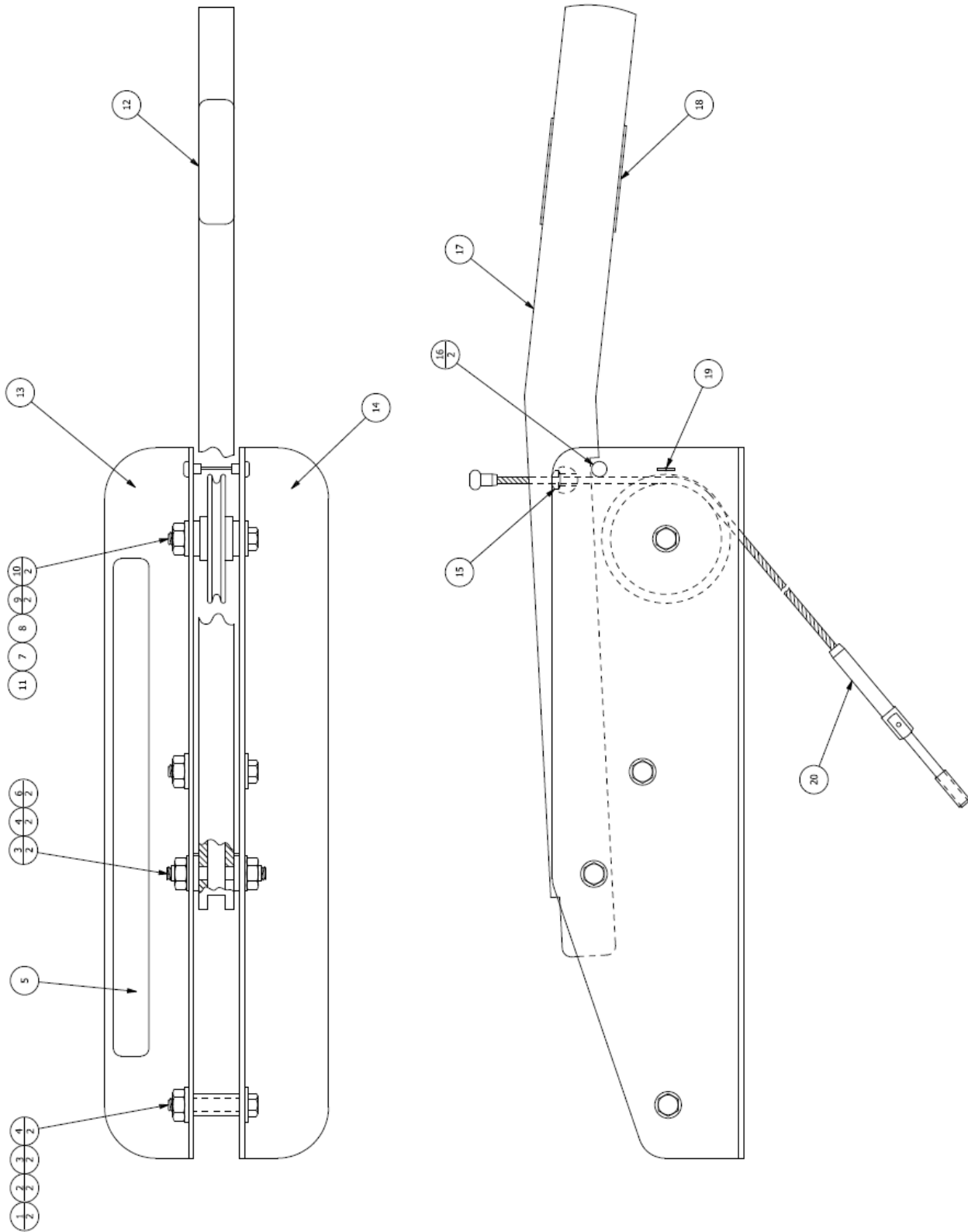

PARTS MANUAL
2100 FLOATS ON CESSNA 172 & 175

ITEM	QTY	PART NO.	PART DESCRIPTION
-	1	21A08000-128	ASS'Y, RETRACT HANDLE
1	2	AN3-10A	BOLT, 10-32, 0.625 GRIP, UNDRILLED, STEEL
2	2	3A08613-001	PLASTIC TUBE
3	6	NAS1149F0332P	WASHER, 0.203 ID, 0.032 THK, STEEL
4	4	NAS679A3W	KAYNAR NUT
5	1	3A3-1115-1	PLACARD
6	2	3A08702-006	PIVOT PIN
7	1	MS20219-2	PULLEY
8	1	AN4-10A	BOLT, 1/4-28, 0.5625 GRIP, UNDRILLED, STEEL
9	2	NAS1149F0463P	WASHER, 0.265 ID, 0.063 THK, STEEL
10	2	NAS1149F0432P	WASHER, 0.265 ID, 0.032 THK, STEEL
11	1	NAS679A4W	KAYNAR NUT
12	1	3A3-1115-2	PLACARD
13	1	3A08003-015	BRACKET
14	1	3A08003-016	BRACKET
15	1	4A08506-002	SWIVEL
16	2	AN470AD4	RIVET
17	1	3A08414-001	HANDLE
18	1	3A3-1115-3	PLACARD
19	1	MS24665-285	COTTER PIN
20	1	21A08000-137	RETRACT CABLE ASS'Y

STEERING & RETRACT SYSTEM INSTALLATION

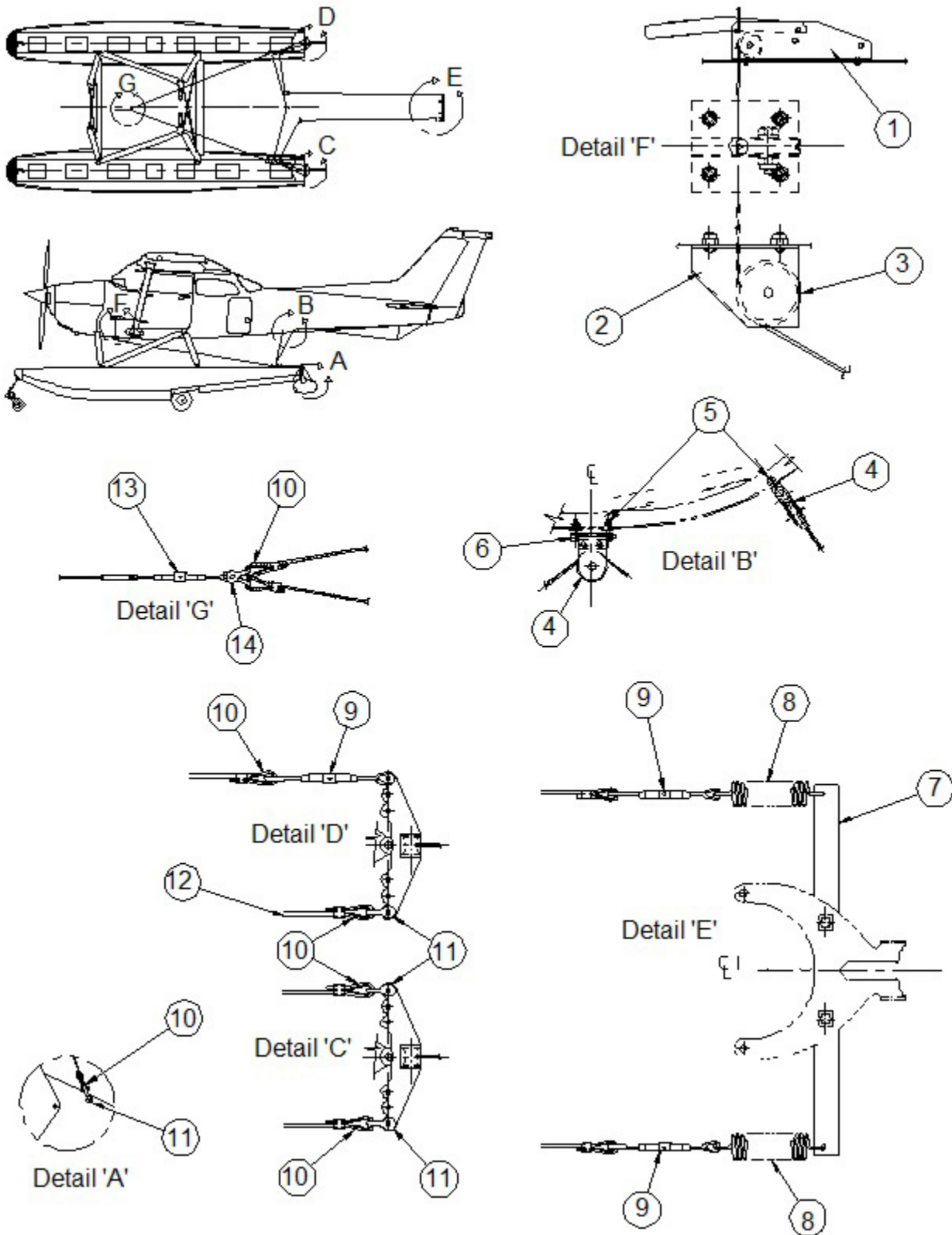

PARTS MANUAL
2100 FLOATS ON CESSNA 172 & 175

ITEM	QTY	PART NO.	PART DESCRIPTION
1	1	21A08000-128	ASSY. – RETRACT HANDLE (SEE DETAIL)
	4	AN526-1032R8	SCREW, TRUSS HEAD, NON STRUCTURAL, CAD 1, STEAL
	4	NAS1149D0363J	WASHER, 0.203 ID, 0.063 THK, ALUMINUM
	4	MS21044N3	NUT, LOCKING, REGULAR HEIGHT, 10-32 UNF
2	1	3A08151-046	PULLEY BRACKET
	4	AN526-1032R8	SCREW, TRUSS HEAD, NON STRUCTURAL, CAD 1, STEAL
	4	NAS1149D0363J	WASHER, 0.203 ID, 0.063 THK, ALUMINUM
	4	MS21044N3	NUT, LOCKING, REGULAR HEIGHT, 10-32 UNF
3	1	MS20219-2	PULLEY
	1	AN4-7A	BOLT, 1/4-28, 0.4375 GRIP, UNDRILLED, STEEL
	2	NAS1149D0463J	WASHER, 0.265 ID, 0.063 THK, ALUMINUM
	1	MS21044N4	NUT, LOCKING, REGULAR HEIGHT, 1/4-28 UNF
4	3	21A08000-125	ASSY. – PULLEY BRACKET
	1	21A08008-150	BRACKET
	1	21A08230-002	SPACER - BLOCK
	1	MS20219-2	PULLEY
	1	AN4-7A	BOLT, 1/4-28, 0.4375 GRIP, UNDRILLED, STEEL
	1	NAS1149D0363J	WASHER, 0.203 ID, 0.063 THK, ALUMINUM
	1	NAS1149D0416J	WASHER, 0.265 ID, 0.016 THK, ALUMINUM
	1	MS21044N4	NUT, LOCKING, REGULAR HEIGHT, 1/4-28 UNF
5	6	AN42B4A	BOLT EYE, 10-32 THREAD, 1/8" GRIP, 17/32" LENGTH
	6	NAS1149D0363J	WASHER, 0.203 ID, 0.063 THK, ALUMINUM
	6	MS21044N3	NUT, LOCKING, REGULAR HEIGHT, 10-32 UNF
6	3	AN3-17A	BOLT, 10-32, 1.5 GRIP, UNDRILLED, STEEL
	3	NAS1149D0363J	WASHER, 0.203 ID, 0.063 THK, ALUMINUM
	3	MS21044N3	NUT, LOCKING, REGULAR HEIGHT, 10-32 UNF
7	1	21A08359-201	EXTENSION – RUDDER HORN
	2	AN3-6A	BOLT, 10-32, 0.375 GRIP, UNDRILLED, STEEL
	2	NAS1149D0363J	WASHER, 0.203 ID, 0.063 THK, ALUMINUM
	2	MS21044N3	NUT, LOCKING, REGULAR HEIGHT, 10-32 UNF
8	2	21A08525-005	SPRING
9	3	MS21251B3S	TURNBUCKLE – BARREL
	3	MS21252-3RS	FORK – TERMINAL
	3	MS20392-2-1	PIN ATTACH
	3	MS24665-132	PIN – COTTER
	3	NAS1149D0316J	WASHER, 0.203 ID, 0.016 THK, ALUMINUM
10	10	AN100-3	THIMBLE – CABLE
	10	18-2-G	NICOPRESS – CLAMP
11	5	MS20115-3	SHACKLE
	5	MS20392-2-11	PIN – ATTACH
	5	MS24665-132	PIN – COTTER

ITEM	QTY	PART NO.	PART DESCRIPTION
12	A/R	3/32 7X 7 S.S.	CABLE (REQUEST LENGTH)
13	1	MS21251B3S	BARREL
	1	MS21252-3RS	FORK
14	2	MS20115-3	SHACKLE
	1	MS20392-2-19	PIN – CLEVIS

SECTION 8 LANDING GEAR

CONTENTS

NOSE GEAR RETRACTION ASSEMBLY	70
NOSE GEAR LOWER ASSEMBLY	73
NOSE WHEEL ASSEMBLY (GROVE)	75
NOSE WHEEL ASSEMBLY (PARKER)	77
MAIN GEAR RETRACTION INSTALLATION.....	79
MAIN GEAR WHEEL GROVE / WIPAIRE ASSEMBLY	82
MAIN GEAR WHEEL CLEVELAND / PARKER ASSEMBLY	84

NOSE GEAR RETRACTION ASSEMBLY

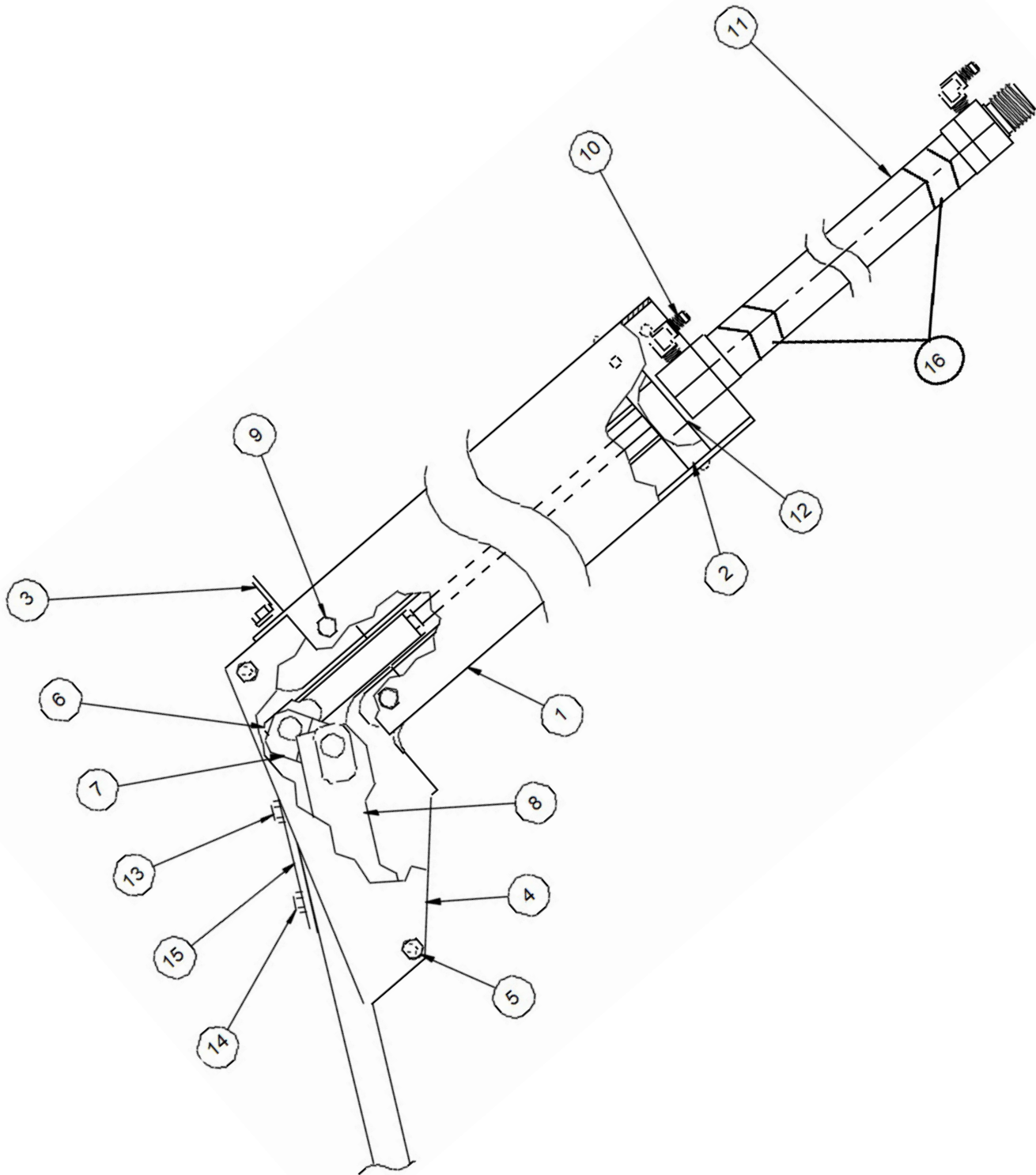

PARTS MANUAL
2100 FLOATS ON CESSNA 172 & 175

ITEM	QTY	PART NO.	PART DESCRIPTION
1	1	21A07000-015	ASSY. – NOSE BOX
	1	21A07323-001	NOSE – BOX
	1	8A01008-080	COVER – ACCESS
	1	30A07567-011	GASKET
	4	AN526-1032R4	SCREW, 10-32 THREAD, 1/4" LENGTH, CARBON STEEL
2	1	21A07237-002	END – CAP - AFT
3	1	21A07359-194	ANGLE
	2	AN4-6A	BOLT, 1/4-28, 0.3125 GRIP, UNDRILLED, STEEL
	2	NAS1149D0463J	WASHER, 0.265 ID, 0.063 THK, ALUMINUM
	2	NAS1149D0416J	WASHER, 0.265 ID, 0.016 THK, ALUMINUM
	2	MS21044N4	NUT, LOCKING, REGULAR HEIGHT, 1/4-28 UNF
4	1	21A07349-003	TRACK – NOSE END L.
	1	21A07349-004	TRACK – NOSE END R.
5	2	AN4-53A	BOLT, 1/4-28 THREAD, 4-15/16" GRIP, 5-13/32 LENGTH
	4	NAS1149D0416J	WASHER, 0.265 ID, 0.016 THK, ALUMINUM
	2	NAS5679-A4W	NUT
6	1	21A07094-002	ROD END - RAM
	1	AN316-5R	NUT - JAMB
7	1	21A07032-005	LINK – DOWN LOCK
	1	21A07509-007	AXLE – SHAFT
	2	3A07530-001	ROLLER
	2	5100-46-H	SNAP RING
8	1	21A07187-009	TROLLEY – SPRING ATTACH
	2	34A07509-008	AXLES - SHAFT
	4	3A07604-001	BLOCK - SLIDE
9	4	AN4-5A	BOLT, 1/4-28, 0.1875 GRIP, UNDRILLED, STEEL
	4	NAS1149D0463J	WASHER, 0.265 ID, 0.063 THK, ALUMINUM
	8	NAS1149D0416J	WASHER, 0.265 ID, 0.016 THK, ALUMINUM
	4	NAS5679-A4W	NUT
10	2	MS20822-4D	ELBOW 90 DEG, 7/16-20 TUBE THREAD, 5-44 PIPE THREAD
11	1	1002571	HYDRAULIC CYLINDER
12	A/R	NAS1149D1416J	WASHER, AIRFRAME, ALUMINUM, TO FIT DIA 1/4"
13	2	AN5-20A	BOLT, 5/16-24, 1.5625 GRIP, UNDRILLED, STEEL
	A/R	NAS1149F0563P	WASHER, 0.328 ID, 0.063 THK, STEEL
	2	MS21044N5	NUT, LOCKING, REGULAR HEIGHT, 5/16-24 UNF
14	2	AN5-21A	BOLT, 5/16-24, 1.6875 GRIP, UNDRILLED, STEEL
	A/R	NAS1149F0563P	WASHER, 0.328 ID, 0.063 THK, STEEL
	2	MS21044N5	NUT, LOCKING, REGULAR HEIGHT, 5/16-24 UNF
15	1	21A06166-001	PLATE – BEARING UPPER
	2	21A09005-262	CLIP-MAGNETIC INDICATOR (NOT SHOWN)
	2	5801	PROXIMITY SWITCH (NOT SHOWN)

ITEM	QTY	PART NO.	PART DESCRIPTION
	4	MS24693-S6	SCREW, COUNTERSUNK , 4-40 UNC, 0.5 LG (NOT SHOWN)
16	2	3A07005-178	CLIP, SWITCH, NOSE & MAIN

NOSE GEAR LOWER ASSEMBLY

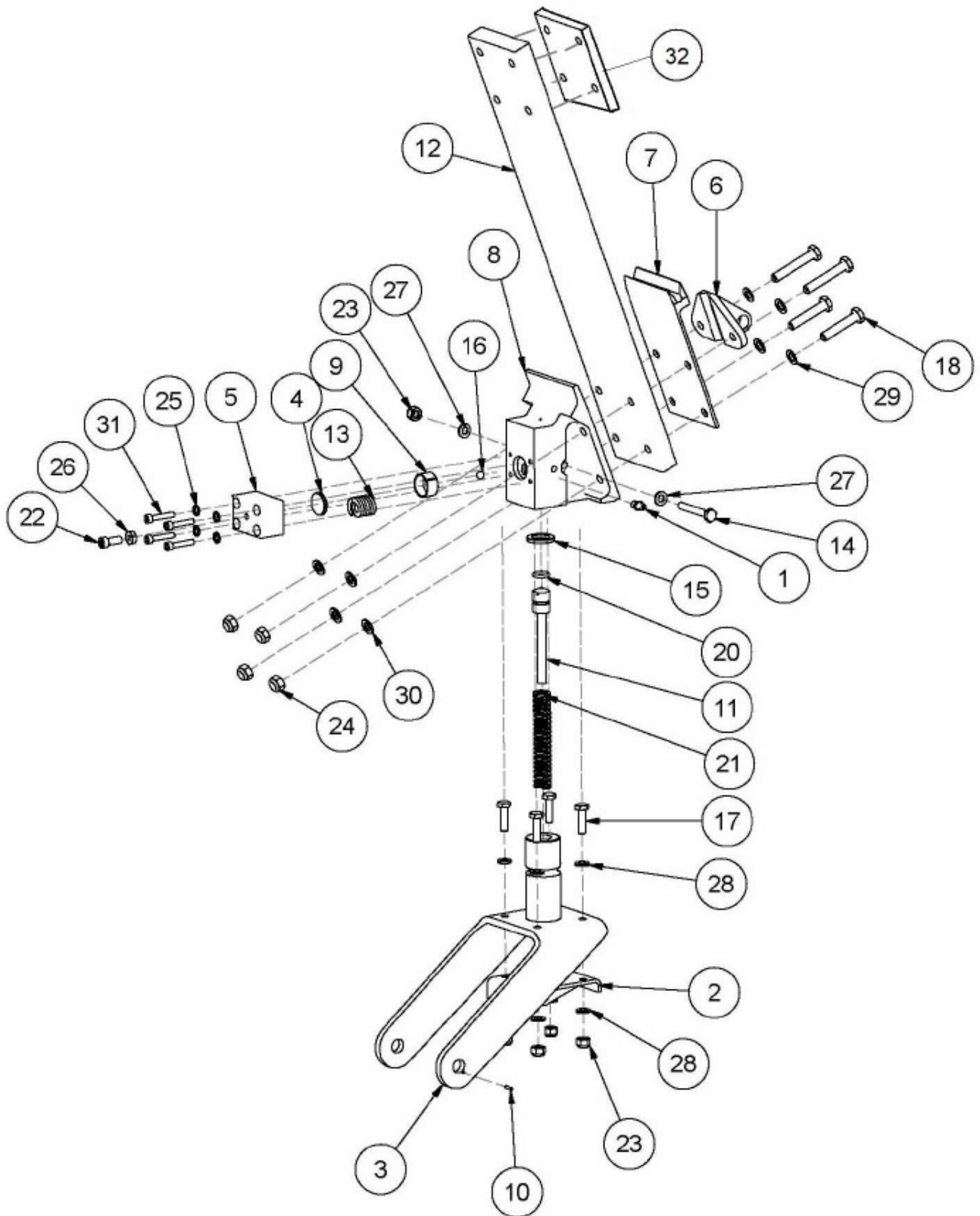

ITEM	QTY	PART NO.	PART DESCRIPTION
1	1	1095K41	COMMON GREASEZERK
2	1	21A06000-020	WELDMENT, PIVOT SHAFT, FORK, NOSE GEAR
3	1	21A06020-001	FORK, NOSE GEAR (2100)
4	1	21A06160-053	PRESSURE PLATE
5	1	21A06194-005	BLOCK - SPRING
6	1	21A06213-006	TOW HOOK NOSE GEAR
7	1	21A06237-001	BEARING PLATE, LOWER, NOSE GEAR
8	1	21A06318-005	BLOCK - PIVOT, NOSE GEAR
9	1	21A06475-006	FRICITION CUP
10	1	21A06476-003	PIN, ANTIROTATION
11	1	21A06605-002	PLUNGER- NOSE WHEEL, 21, 23,3,34
12	1	21A06653-001	SPRING NOSE GEAR
13	1	21A06705-005	PRESSURE SPRING
14	1	30A06702-016	BOLT - MODIFIED, PIVOT BLOCK
15	1	3A06602-001	THRUST WASHER
16	1	9528K15	1/4" CHROME BALL BEARING
17	4	AN4-7A	BOLT, 1/4-28, 0.4375 GRIP, UNDRILLED, STEEL
18	2	AN5-14A	BOLT, 5/16-24, 1.0625 GRIP, UNDRILLED, STEEL
19	2	AN5-16A	BOLT, 5/16-24 THREAD, 1-5/16" GRIP, 1-27/32" LENGTH
20	1	AN6227-9	O-RING
21	1	M62-350	SPRING
22	1	MS16997-60	SOCKET HEAD CAP SCREW
23	5	MS21044N4	NUT, LOCKING, REGULAR HEIGHT, 1/4-28 UNF
24	4	MS21044N5	NUT, LOCKING, REGULAR HEIGHT, 5/16-24 UNF
25	4	MS35333-39	LOCKWASHER, INTERNAL TOOTH, TO FIT DIA #10
26	1	MS35649-2252	NUT, PLAIN HEXAGON, 1/4-20 THREAD
27	2	NAS1149D0463J	WASHER, 0.265 ID, 0.063 THK, ALUMINUM
28	8	NAS1149F0463P	WASHER, 0.265 ID, 0.063 THK, STEEL
29	4	NAS1149F0532P	WASHER, 0.328 ID, 0.032 THK, STEEL
30	4	NAS1149F0563P	WASHER, 0.328 ID, 0.063 THK, STEEL
31	4	NAS1352-316P	SOCKET HEAD CAP SCREW
32	1	21A06166-001	PLATE – BEARING, NOSE SPRING
	4	AN5-20A	BOLT, 5/16-24, 1.5625 GRIP, UNDRILLED, STEEL (NOT SHOWN)
	4	NAS1149F0563P	WASHER, 0.328 ID, 0.063 THK, STEEL (NOT SHOWN)
	4	MS21044N5	NUT, LOCKING, REGULAR HEIGHT, 5/16-24 UNF (NOT SHOWN)

NOSE WHEEL ASSEMBLY (GROVE)

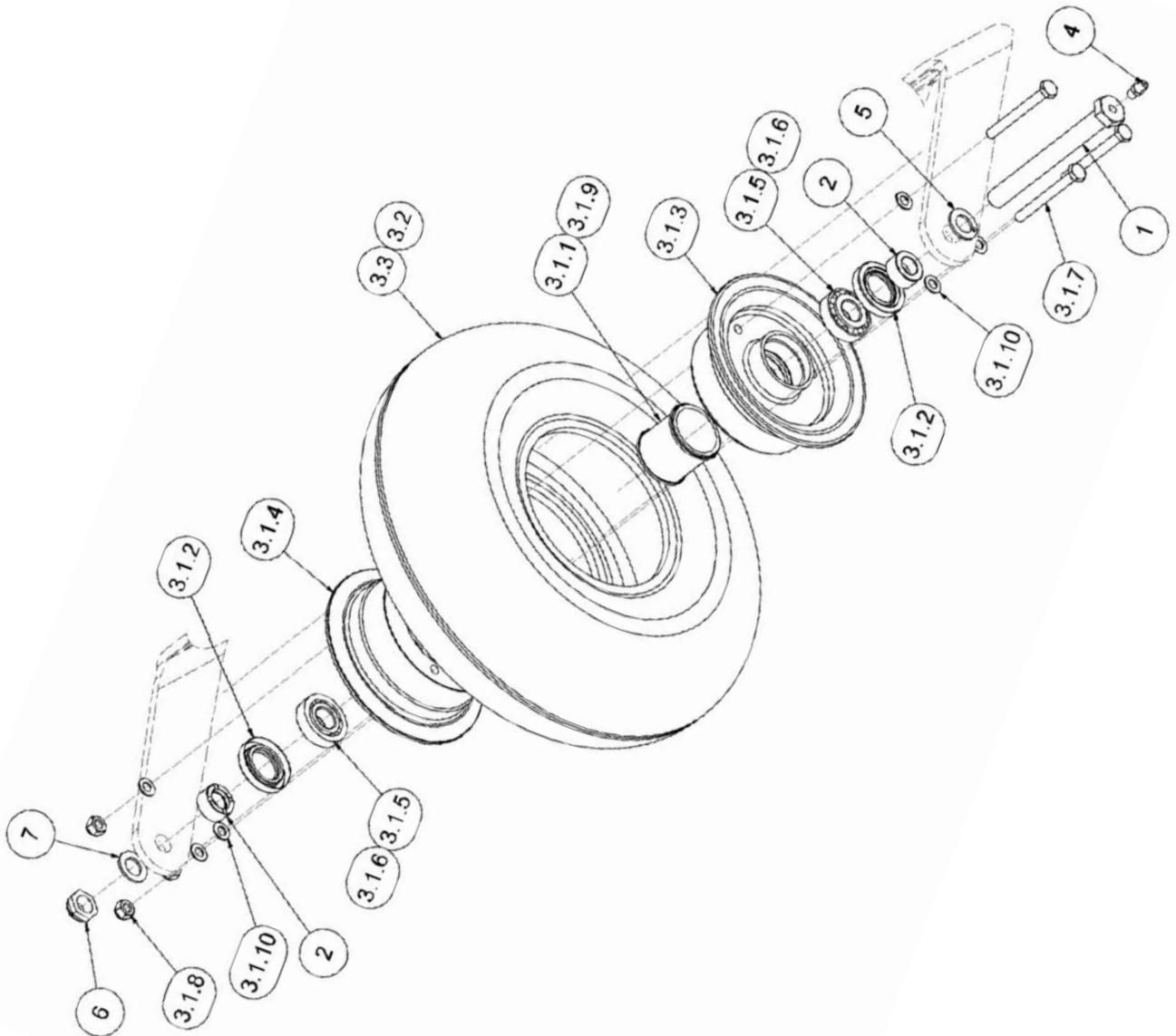

ITEM	QTY	PART NO.	PART DESCRIPTION
1	1	1005927	BOLT, AXLE, NOSE GEAR
2	2	1005929	SPACER
3	1	1005931	ASSEMBLY, NOSE WHEEL
3.1	1	49-12AF-001	ASSEMBLY, WHEEL, GROVE
3.1.1	1	010-019	GREASE RETAINER
3.1.2	2	471570	SEAL, TIMKEN (EQUIVALENT TO GROVE OEM P/N 010-026)
3.1.3	1	015-020A	WHEEL HALF INNER
3.1.4	1	016-020AF	WHEEL HALF OUTER
3.1.5	2	A4050	BEARING CORE
3.1.6	2	A4138	BEARING CONE
3.1.7	3	AN4-23A	BOLT, 1/4-28, 1.9375 GRIP, UNDRILLED, STEEL
3.1.8	3	MS21044N4	NUT, LOCKING, REGULAR HEIGHT, 1/4-28 UNF
3.1.9	2	MS28775-029	O RING, I.D 1.489, O.D. 1.629. .070 THICK
3.1.10	6	NAS1149F0416	WASHER, 0.265 ID, 0.016 THK, STEEL
3.2	1	XA1AA*	INNER TUBE, 2.80 X 4
3.3	1	AD1A2*	TIRE, 2.50 / 2.80 - 4
4	1	1095K41	COMMON GREASEZERK
5	1	3A06702-003	MODIFIED WASHER
6	1	MS21083N8	NUT, SELFLOCKING, 1/2-20 THREAD, NYLON INSERT, 250 DEG.
7	1	NAS1149D0863J	WASHER, 0.515 ID, 0.063 THK, ALUMINUM

* Any alternate tire (tube type) which is TSO-approved, matches the listed tire's dimensions, and meets its speed/load/ply ratings may be used. Equivalent tubes may also be used.

NOSE WHEEL ASSEMBLY (PARKER)

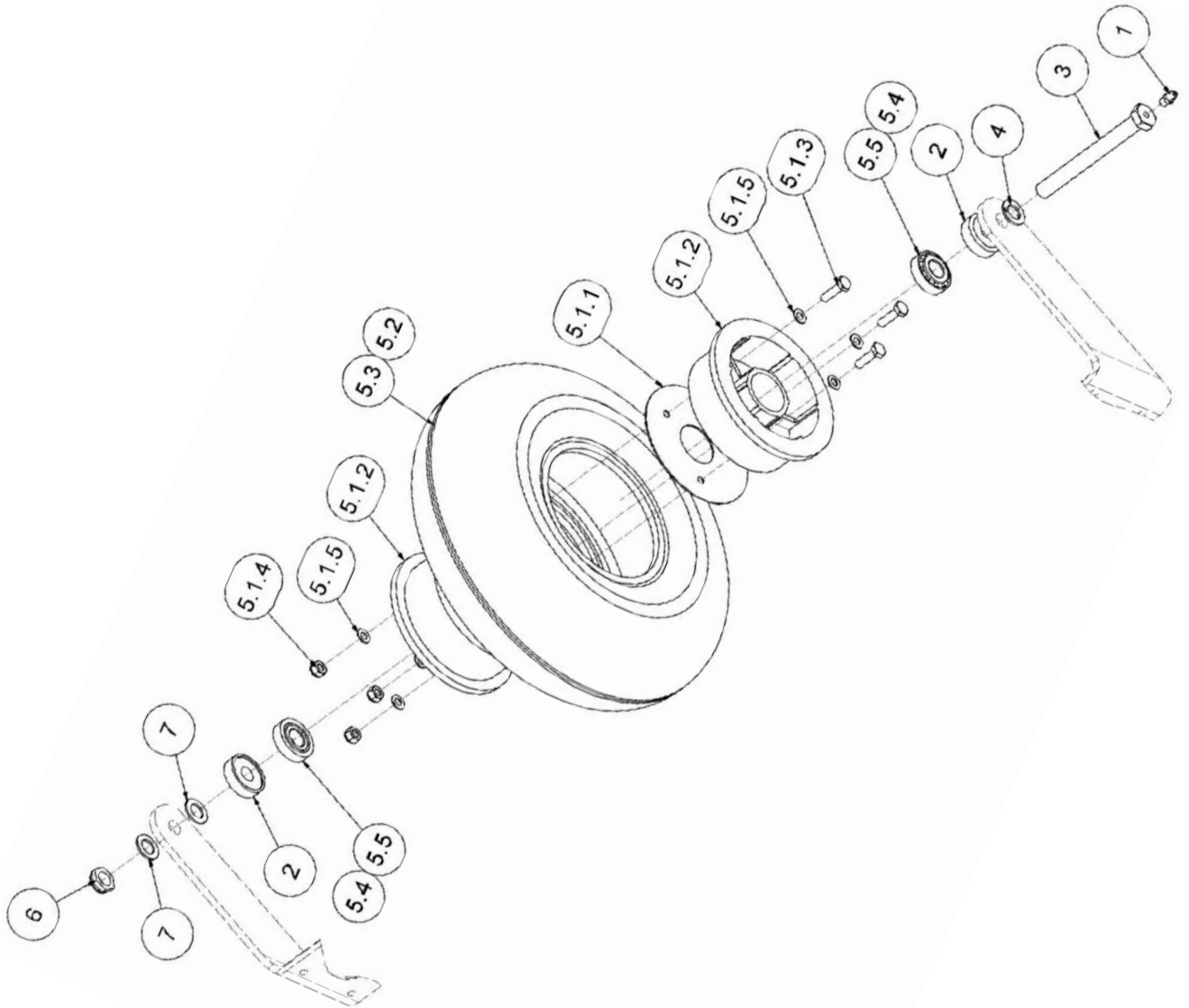

ITEM	QTY	PART NO.	PART DESCRIPTION
1	1	1095K41	COMMON GREASEZERK
2	2	3A06259-001	SPACER
3	1	3A06702-002	BOLT, MODIFIED, AXLE, NOSE GEAR
4	1	3A06702-003	MODIFIED WASHER
5	1	21A06000-021	NOSE WHEEL ASSEMBLY
5.1	1	D-30380	PARKER WHEEL ASSEMBLY
5.1.1	1	068-30373	GASKET
5.1.2	2	161-30382	WHEEL HALF
5.1.3	3	AN4-7A	BOLT, 1/4-28, 0.4375 GRIP, UNDRILLED, STEEL
5.1.4	3	MS21044N4	NUT, LOCKING, REGULAR HEIGHT, 1/4-28 UNF
5.1.5	6	NAS1149F0432P	WASHER, 0.265 ID, 0.032 THK, STEEL
5.2	1	XA1AA*	INNER TUBE, 2.80 X 4
5.3	1	AD1A2*	TIRE, 2.50 / 2.80 - 4
5.4	2	A4050	BEARING CORE
5.5	2	A4138	BEARING CONE
6	1	MS21083N8	NUT, SELFLOCKING, 1/2-20 THREAD, NYLON INSERT, 250 DEG.
7	2	NAS1149D0863J	WASHER, 0.515 ID, 0.063 THK, ALUMINUM

* Any alternate tire (tube type) which is TSO-approved, matches the listed tire's dimensions, and meets its speed/load/ply ratings may be used. Equivalent tubes may also be used.

MAIN GEAR RETRACTION INSTALLATION

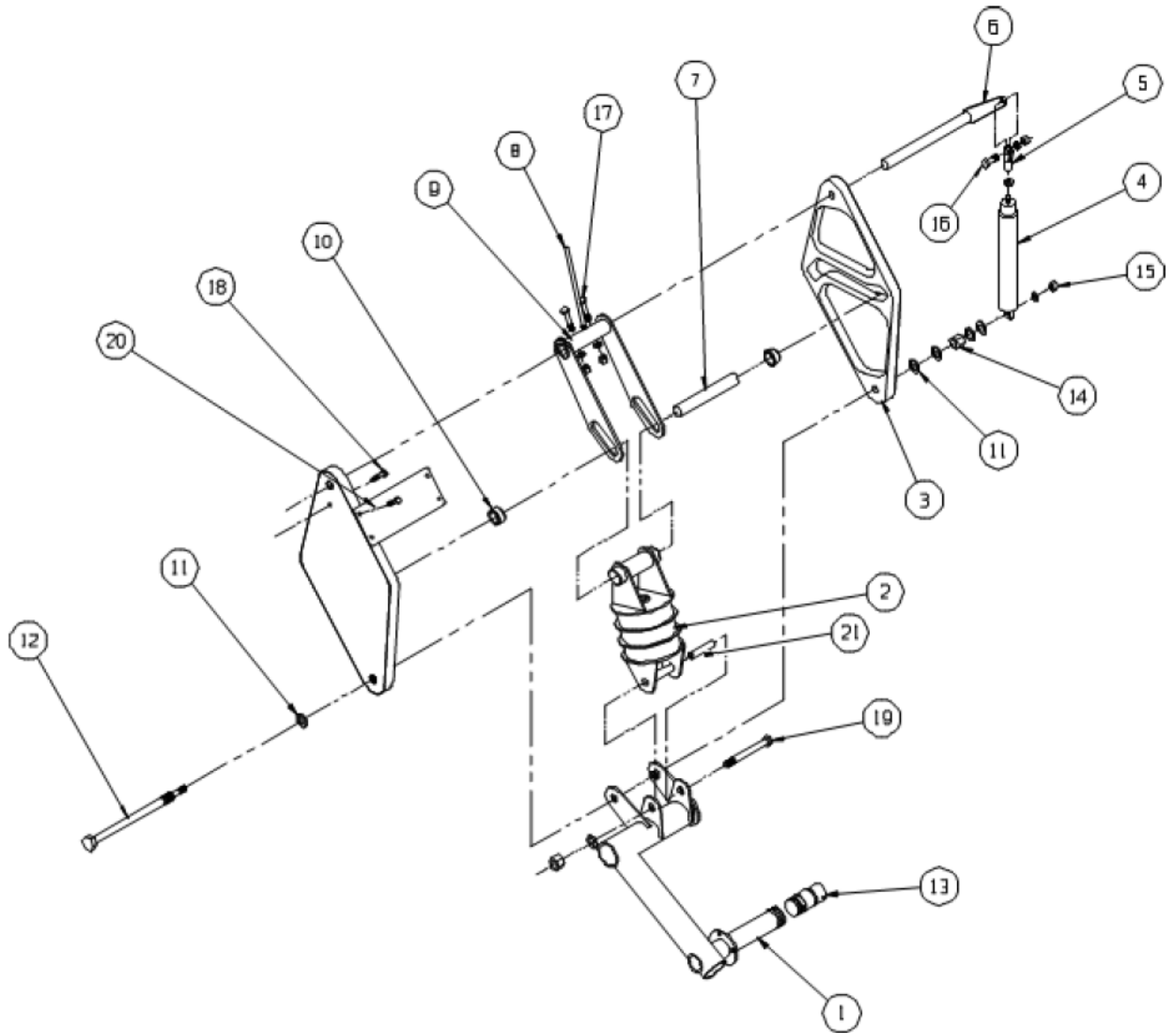

ITEM	QTY	PART NO.	PART DESCRIPTION
1	1	21A04000-077	ASSY. – DRAG LINK L.
	1	21A04000-076	ASSY. – DRAG LINK R.
	2	08FDU12	BEARING
2	1	21A04000-073	ASSY. SHOCK STRUT
	1	21A04000-074	ASSY. - UPPER END
	1	21A04000-075	ASSY. – LOWER END
	2	1095K41	ZERK – GREASE
	2	NAS1149D0416J	WASHER, 0.265 ID, 0.016 THK, ALUMINUM
	2	NAS1149D0463J	WASHER, 0.265 ID, 0.063 THK, ALUMINUM
	1	1002087	DUAL BUSHING ASSEMBLY
	1	1001100	BUSHING ASSEMBLY
	1	21A04503-004	RETAINING PIN
	1	MS24665-151	COTTER PIN
	1	21A04585-002	SLEEVES
3	1	21A05114-005	TRACK – MAIN GEAR L.
	1	21A05114-006	TRACK – MAIN GEAR R.
	1	10DU12	BEARING - UPPER
	1	08DU12	BEARING – LOWER
4	1	1002574	CYLINDER
	2	MS20822-4D	ELBOW 90 DEG, 7/16-20 TUBE THREAD, 5-44 PIPE THREAD
5	1	21A05705-002	ROD END
	1	AN316-5	JAMB NUT
	1	21A05260-005	SPACER
	1	MS20002C6	WASHER TO FIT DIA 3/8", COUNTERSUNK (CHAMFERED EDGE GOES AGAINST CYLINDER)
6	1	21A05000-017	ARM – RETRACT L.
	1	21A05000-016	ARM – RETRACT R.
7	1	21A04454-006	AXLE – SHOCK STRUT
8	1	21A05000-022	INDICATOR ASSY.
9	1	21A05000-018	GEAR ACTUATOR
10	2	21A05520-003	ROLLER – TRACK
11	2	93783A033	WASHERS, PRESSURE SEALING, W/ ZINC PLATING, 1/2" DIA
12	1	21A05000-019	BOLT, MAIN GEAR
	1	21A05735-001	BOLT
	1	21A05476-002	STUD
13	1	21A04263-007	RETAINER - GREASE
	2	MS28775-210	O RING, DIA 0.734
	1	1095K41	ZERK – GREASE
14	1	MS21044N8	NUT, LOCKING, REGULAR HEIGHT, 1/2-20 UNF
	2	NAS1149F0863P	WASHER, AIRFRAME, TO FIT DIA 1/2"
15	1	MS21083N5	NUT, LOCKING, LOW HEIGHT, 5/16-24 UNF

PARTS MANUAL
2100 FLOATS ON CESSNA 172 & 175

ITEM	QTY	PART NO.	PART DESCRIPTION
	A/R	NAS1149F0563P	WASHER, 0.328 ID, 0.063 THK, STEEL
16	1	1005875	ASSEMBLY, PIN, CLEVIS, MAGNET HOLDER
	2	NAS1149F0563P	WASHER, 0.328 ID, 0.063 THK, STEEL
	1	MS21044N5	NUT, LOCKING, REGULAR HEIGHT, 5/16-24 UNF
17	2	NAS6204-17	BOLT, 1/4-28 THREAD, 1.432" LENGTH, 1.062" GRIP
	4	NAS1149D0416J	WASHER, 0.265 ID, 0.016 THK, ALUMINUM
	2	MS21044N4	NUT, LOCKING, REGULAR HEIGHT, 1/4-28 UNF
18	8	AN3-6A	BOLT, 10-32, 0.375 GRIP, UNDRILLED, STEEL
	8	NAS1149D0316J	WASHER, 0.203 ID, 0.016 THK, ALUMINUM
	8	NAS1149D0363J	WASHER, 0.203 ID, 0.063 THK, ALUMINUM
	8	MS21044N3	NUT, LOCKING, REGULAR HEIGHT, 10-32 UNF
19	1	AN8-33A	BOLT, 1/2-20 THREAD, 2-11/16" GRIP, 3-15/32" LENGTH
	1	NAS1149F0832P	WASHER, 0.515 ID, 0.032 THK, STEEL
	1	NAS1149F0863P	WASHER, AIRFRAME, TO FIT DIA 1/2"
	1	MS21044N8	NUT, LOCKING, REGULAR HEIGHT, 1/2-20 UNF
20	1	21A05003-079	PLATE - SEPARATING
	4	AN3-5A	BOLT, 10-32, 0.25 GRIP, UNDRILLED, STEEL
	8	NAS1149D0316J	WASHER, 0.203 ID, 0.016 THK, ALUMINUM
	4	MS21044N3	NUT, LOCKING, REGULAR HEIGHT, 10-32 UNF
21	1	21A04547-004	BUSHING, LOWER, SHOCK STRUT
	2	21A09005-262	CLIP, MAGNETIC INDICATOR (NOT SHOWN)
	2	5801	PROXIMITY SWITCH (NOT SHOWN)
	4	MS24693-S6	SCREW, COUNTERSUNK , 4-40 UNC, 0.5 LG (NOT SHOWN)

MAIN GEAR WHEEL GROVE / WIPAIRE ASSEMBLY

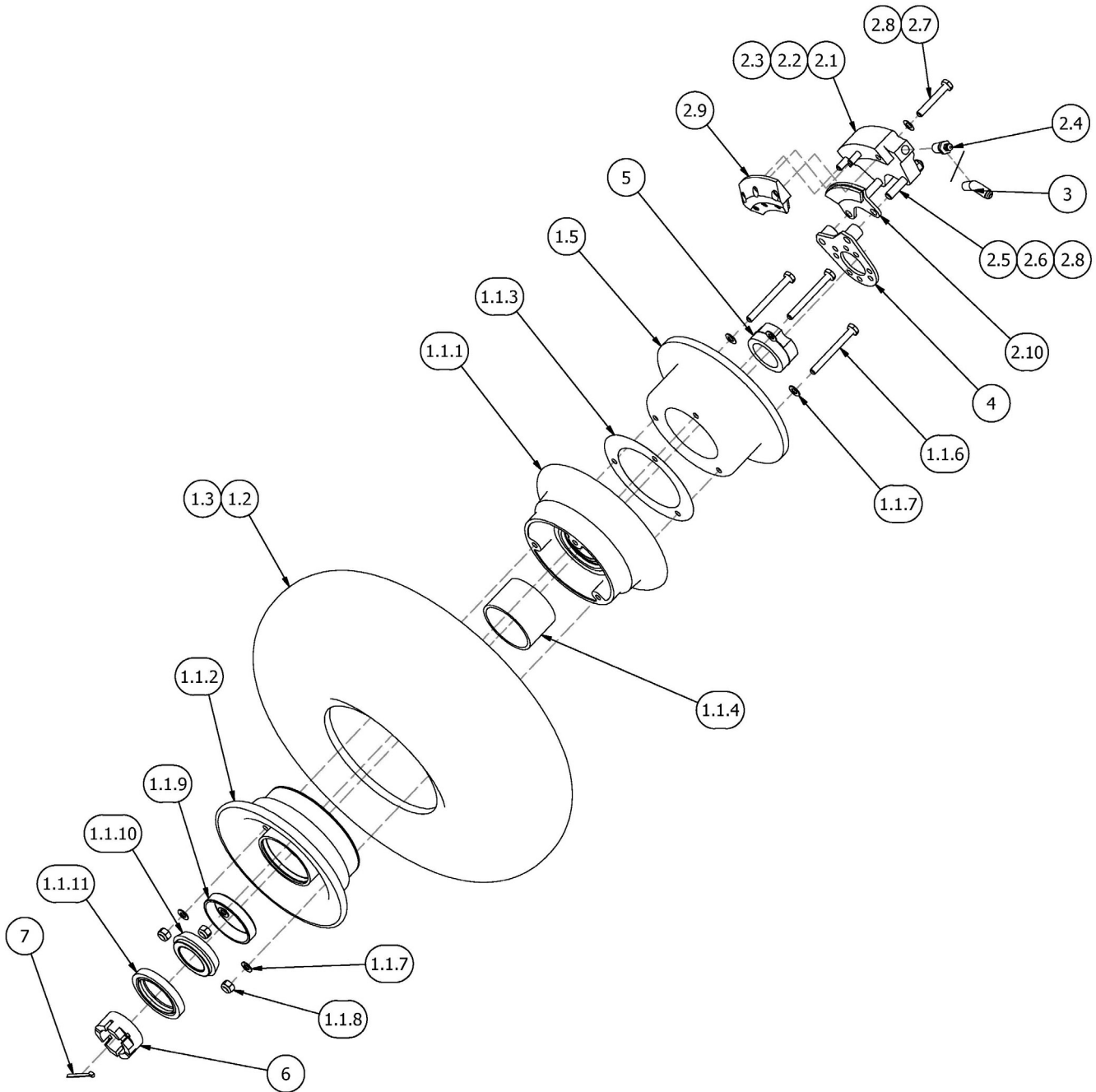

PARTS MANUAL
2100 FLOATS ON CESSNA 172 & 175

ITEM	QTY	PART NO.	PART DESCRIPTION
1	1	1002141	ASSY, MAIN WHEEL, GROVE, 2100 (INCLUDES TIRE AND TUBE)
1.1	1	1002142	ASSY, RIM & BEARINGS, GROVE, 2100
1.1.1	1	015-002	WHEEL HALF, INNER (REF)
1.1.2	1	016-002	WHEEL HALF, OUTER (REF)
1.1.3	1	3A04620-001	GASKET - TEFLON
1.1.4	1	010-009	GREASE RETAINER
1.1.5	1	018-001	BRAKE DISC (NOMINAL THICKNESS 0.190", MINIMUM 0.165")
1.1.6	3	AN4-23A	BOLT, 1/4-28, 1.9375 GRIP, UNDRILLED, STEEL
1.1.7	6	NAS1149F0432P	WASHER, 0.265 ID, 0.032 THK, STEEL
1.1.8	3	MS21044N4	NUT, LOCKING, REGULAR HEIGHT, 1/4-28 UNF
1.1.9	2	08231	BEARING CUP
	-	08231CP	BEARING CUP (CHROME, REF)
1.1.10	2	08125	BEARING CONE
	-	08125CP	BEARING CONE (CHROME, REF)
1.1.11	2	473237	SEAL - INSIDE/OUTSIDE
1.2	1	AA1D4*	TIRE -TYPE III 5.00 X 5, 6 PLY
1.3	1	XA1AC*	TUBE 5.00 X 5
2	1	32-1	BRAKE ASSEMBLY
2.1	1	023-005	CALIPER BODY (REF)
2.2	2	017-003	PISTON (REF)
2.3	2	MS28775-217	O-RING, HYDRAULIC
2.4	1	220-0063	BLEEDER ASSEMBLY
2.5	2	013-001	TORQUE PIN (REF)
2.6	2	MS21044N4	NUT, LOCKING, REGULAR HEIGHT, 1/4-28 UNF
2.7	3	AN4H-15A	BOLT
2.8	5	NAS1149F0416P	WASHER, 0.265 ID, 0.016 THK, STEEL
2.9	1	10-3	ASS'Y - BACK PLATE (REF)
2.9.1	1	RA66-111	LINING (PAD)
2.9.2	3	066-001	RIVET
	A/R	105-00200 (ALT)	RIVET (ALTERNATE PN)
2.10	1	11-2	ASS'Y - PRESSURE PLATE
2.10.1	1	RA66-111	LINING (PAD)
2.10.2	3	066-001	RIVET
	3	105-00200 (ALT)	RIVET (ALTERNATE PN)
3	1	MS20823-3D	FITTING 45° BRAKE LINE
4	1	020-001	BRAKE TORQUE PLATE
5	1	3A04093-001	SPACER
6	1	3A04268-003	NUT - AXLE
7	1	MS24665-351	COTTER PIN

* Any alternate tire (tube type) which is TSO-approved, matches the listed tire's dimensions, and meets its speed/load/ply ratings may be used. Equivalent tubes may also be used.

MAIN GEAR WHEEL CLEVELAND / PARKER ASSEMBLY

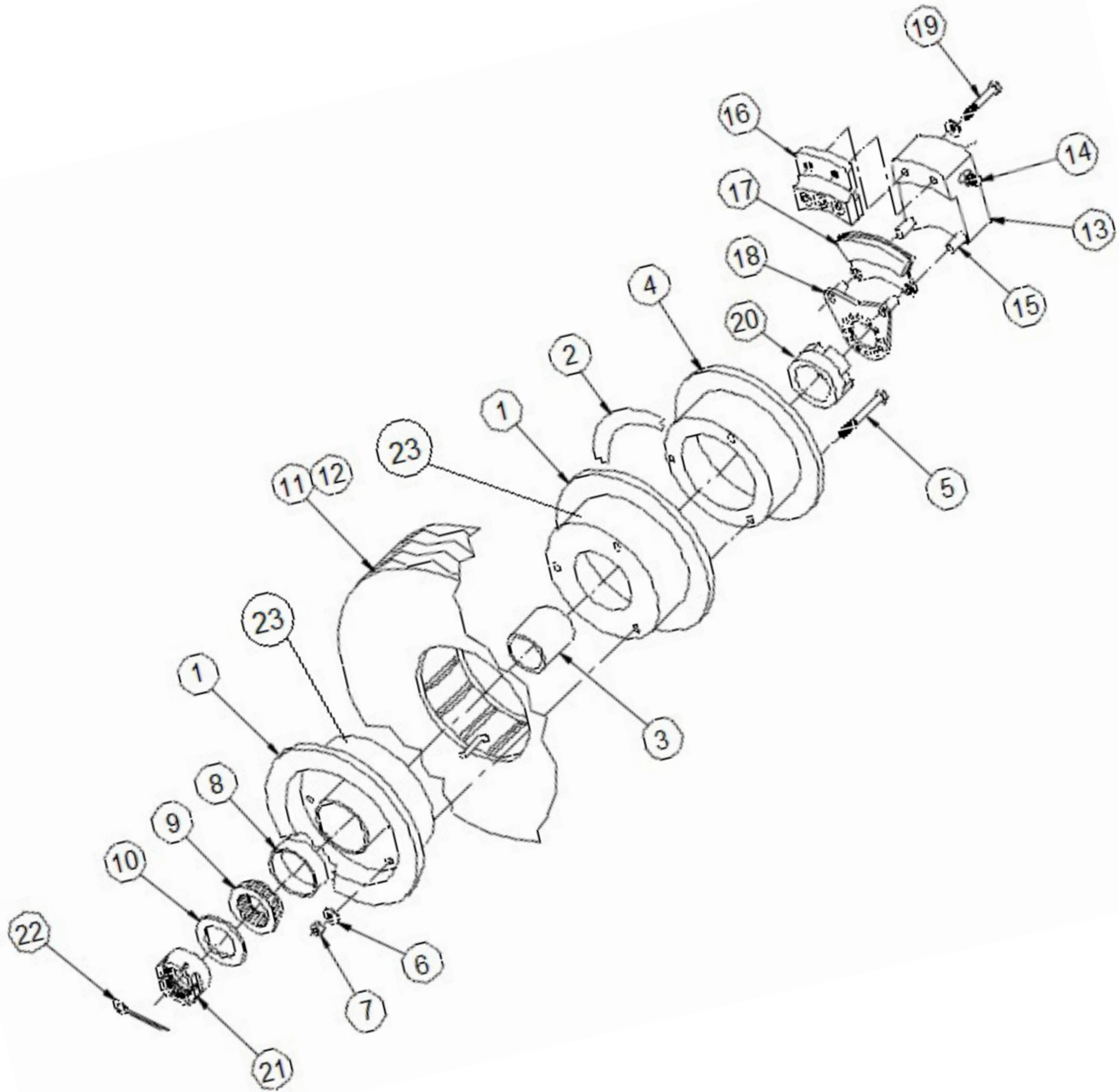

PARTS MANUAL
2100 FLOATS ON CESSNA 172 & 175

ITEM	QTY	PART NO.	PART DESCRIPTION
1	1	3A04000-002	ASSY. – WHEEL (W/ TUBE & TIRE)
	1	3A04000-060	ASSY. - WHEEL
2	1	3A04620-001	GASKET - TEFLON
3	1	3A04616-001	GREASE RETAINER
4	1	164-01700	BRAKE DISC
5	3	AN4-22A	BOLT, 1/4-28, 1.8125 GRIP, UNDRILLED, STEEL
6	3	NAS1149F0432P	WASHER, 0.265 ID, 0.032 THK, STEEL
7	3	MS21044N4	NUT, LOCKING, REGULAR HEIGHT, 1/4-28 UNF
8	2	8231	BEARING CUP
	2	8231CP	BEARING CUP, CHROME (OPT.)
9	2	8125	BEARING CONE
	2	8125CP	BEARING CONE, CHROME (OPT.)
10	2	473237	SEAL - INSIDE/OUTSIDE
11	1	AA1D4*	TIRE –TYPE III
12	1	XA1AC*	TUBE
	1	075-00800	ASSY. – BRAKE AND TORQUE PLATE
13	1	21A04000-096	ASSY. – CALIPER (RIGHT)
	1	21A04000-097	ASSY. – CALIPER (LEFT)
	1	062-00300	PISTON
	1	AN6227-23	“O” RING
	1	MS20823-3D	FITTING - 45 DEGREES (BRAKE LINE)
14	1	081-30619	SEAT – BLEEDER
	1	79-3	SCREW – BLEEDER
	1	183-1	CAP – BLEEDER
15	2	069-00400	ANCHOR BOLT
	2	NAS1149F0463P	WASHER, 0.265 ID, 0.063 THK, STEEL
	2	MS21044N4	NUT, LOCKING, REGULAR HEIGHT, 1/4-28 UNF
16	1	074-02700	ASSY. – BACK PLATE
	1	064-00500	PLATE – BACK
	1	066-10600	LINING
	3	105-00200	RIVET
17	1	073-04800	ASSY. – PRESSURE PLATE
	1	063-00500	PLATE - PRESSURE
	1	066-10600	LINING
	3	105-00200	RIVET
18	1	3A04711-001	BRAKE TORQUE PLATE - LEFT
	1	3A04711-002	BRAKE TORQUE PLATE – RIGHT
19	1	AN4H15A	BOLT, 1/4-28 THREAD, 1-3/16" GRIP, 1-21/32" LENGTH
	1	NAS1149F0432P	WASHER, 0.265 ID, 0.032 THK, STEEL
20	1	3A04093-001	SPACER
21	1	3A04268-003	NUT – AXLE

ITEM	QTY	PART NO.	PART DESCRIPTION
22	1	MS24665-351	COTTER PIN
23	1	40-78A	WHEEL ASSEMBLY, EXTERNAL, 5.00 X 5

* Any alternate tire (tube type) which is TSO-approved, matches the listed tire's dimensions, and meets its speed/load/ply ratings may be used. Equivalent tubes may also be used.

SECTION 9

STRUTS, STEPS, WIRES AND SPREADER BARS

CONTENTS

STRUTS, WIRES & SPREADER BARS	88
FUSELAGE STEPS INSTALLATION.....	91

STRUTS, WIRES & SPREADER BARS

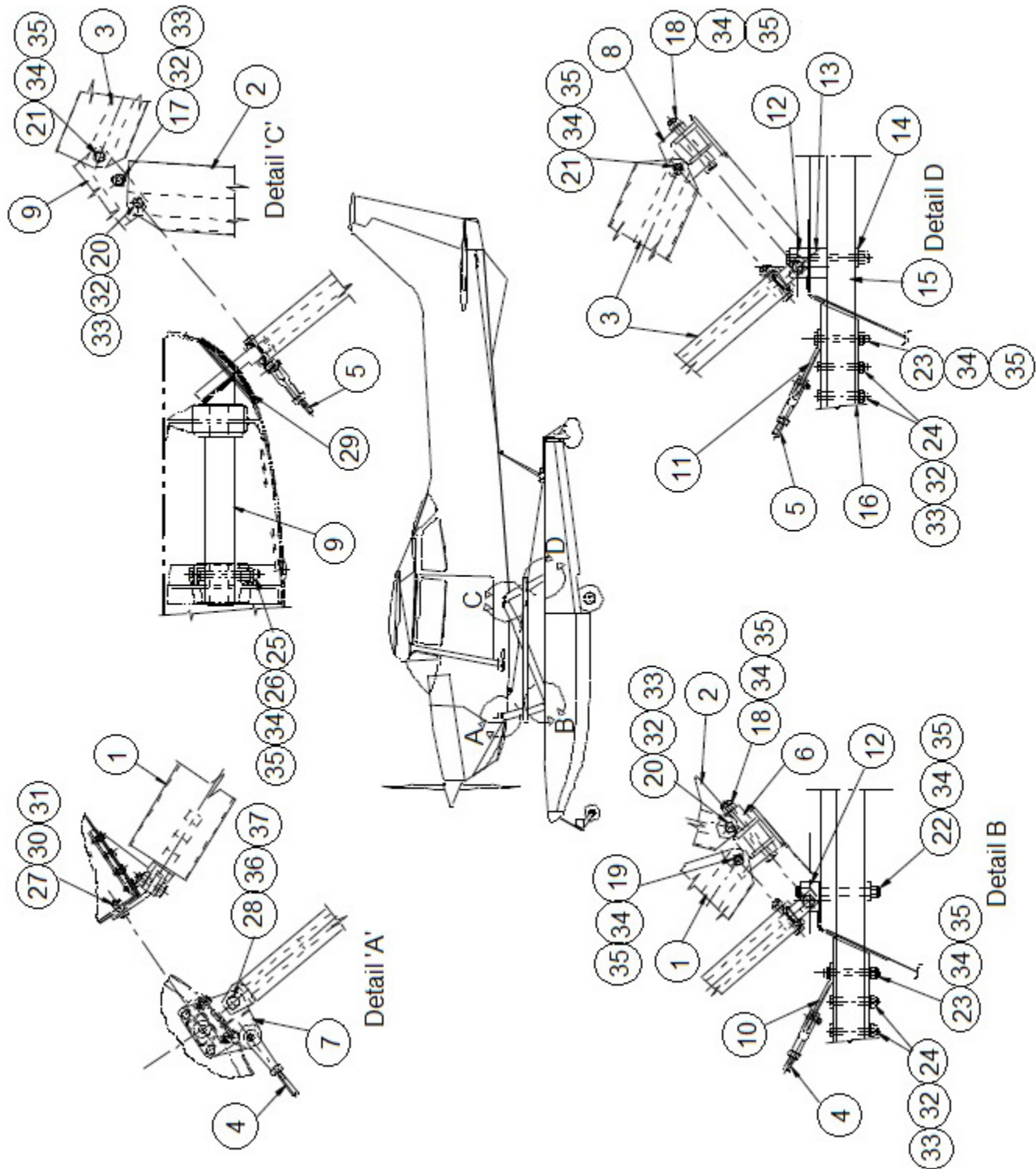

PARTS MANUAL
2100 FLOATS ON CESSNA 172 & 175

ITEM	QTY	PART NO.	PART DESCRIPTION
1	2	21A02000-145	ASSY. – FRONT STRUT
	1	21A02334-020	STRUT
	1	21A02053-008	FITTING - UPPER
	4	AN5-14A	BOLT, 5/16-24, 1.0625 GRIP, UNDRILLED, STEEL
	8	NAS1149D0363J	WASHER, 0.203 ID, 0.063 THK, ALUMINUM
	4	MS21044N3	NUT, LOCKING, REGULAR HEIGHT, 10-32 UNF
2	2	2A02000-228	ASSY. - STRUT – CENTER
3	2	21A02000-161	ASSY. – STRUT – REAR
4	2	21A02000-136	ASSY. – DRAG WIRE – FWD
	1	AN705AC-4925	WIRE
	1	AN665-34LS	CLEVIS L.
	1	AN665-34RS	CLEVIS R.
	1	AN316C4L	NUT CHECK L.
	1	AN316C4R	NUT CHECK R.
	2	MS20392-3C15	PIN – CLEVIS
	2	MS24665-151	PIN – COTTER
5	2	21A02000-137	ASSY. – DRAG WIRE – AFT
	1	AN704AC-5225	WIRE
	1	AN665-46LS *	CLEVIS L.
	1	AN665-46RS *	CLEVIS R.
	1	AN316-C5L	NUT CHECK L.
	1	AN316-C5R	NUT CHECK R.
	2	MS20392-4C17	PIN – CLEVIS
	2	MS24665-152	PIN – COTTER
6	2	21A02062-009	FITTING – LOWER FRONT STRUT
7	1	21A02000-141	ASSY. - FITTING – UPPER FRONT STRUT L.
	1	21A02000-142	ASSY. – FITTING – UPPER FRONT STRUT R.
8	2	21A02062-010	FITTING – LOWER AFT STRUT
9	1	21A02000-177	ASSY. – MAIN FUSELAGE FITTING L.
	1	21A02095-004	BUSHING - INBOARD
	1	21A02083-001	BUSHING - OUTBOARD
	1	MS16562-75	ROLL PIN
	1	21A02000-178	ASSY. – MAIN FUSELAGE FITTING R.
	1	21A02095-004	BUSHING - INBOARD
	1	21A02083-001	BUSHING - OUTBOARD
	1	MS16562-75	ROLL PIN
10	2	21A02462-005	WIRE PULL LOWER FWD
11	2	21A02519-007	WIRE PULL LOWER AFT
12	4	21A03032-006	BLOCK – DECK FITTING
13	4	21A03214-003	SPACER
14	4	21A03154-007	CAP

ITEM	QTY	PART NO.	PART DESCRIPTION
15	4	21A03115-001	TUBE – SPREADER BAR MOUNT
16	2	21A03356-047	SPREADER BAR
17	2	AN45-11A	BOLT EYE, 5/16-24 THREAD, 5/16" BOLT SIZE, 11/16" GRIP, 1-7/32" LENGTH
18	4	AN6-31A	BOLT, SHOULDER, GEAR ACTUATOR, 1450
19	2	AN6-15A	BOLT, 3/8-24, 1.0625 GRIP, UNDRILLED, STEEL
20	2	AN5-14A	BOLT, 5/16-24, 1.0625 GRIP, UNDRILLED, STEEL
21	4	AN6-17A	BOLT, 3/8-24, 1.3125 GRIP, UNDRILLED, STEEL
22	8	AN6-41A	BOLT, 3/8-24, 3.5625 GRIP, UNDRILLED, STEEL
23	4	AN6-26A	BOLT, SIZE 3/8-24, LENGTH 1/64 - 2-53/64, GRIP LENGTH 2-3/16
24	8	AN5-24A	BOLT, 5/16-24 THREAD, 2-1/16" GRIP, 2-19/32" LENGTH
25	2	AN6-35A	BOLT, 3/8-24 THREAD, 3-1/16" GRIP, 3-45/64 LENGTH
26	4	21A02095-003	BUSHING
27	10	AN4-6A	BOLT, 1/4-28, 0.3125 GRIP, UNDRILLED, STEEL
28	2	AN7-13A	BOLT, 7/16-20, 0.8125 GRIP, UNDRILLED, STEEL
29	2	21A02010-018	COVER – GEAR OPENING
30	20	NAS1149D0463J	WASHER, 0.265 ID, 0.063 THK, ALUMINUM
31	10	MS21044N4	NUT, LOCKING, REGULAR HEIGHT, 1/4-28 UNF
32	28	NAS1149F0563P	WASHER, 0.328 ID, 0.063 THK, STEEL
33	14	MS21044N5	NUT, LOCKING, REGULAR HEIGHT, 5/16-24 UNF
34	40	NAS1149D0663J	WASHER, 0.39 ID, 0.063 THK, ALUMINUM
35	20	MS21044N6	NUT, LOCKING, REGULAR HEIGHT, 3/8-24 UNF
36	2	NAS1149D0763J	WASHER, 0.453 ID, 0.063 THK, ALUMINUM
37	2	MS21044N7	NUT, LOCKING, REGULAR HEIGHT, 7/16-20 UNF

FUSELAGE STEPS INSTALLATION

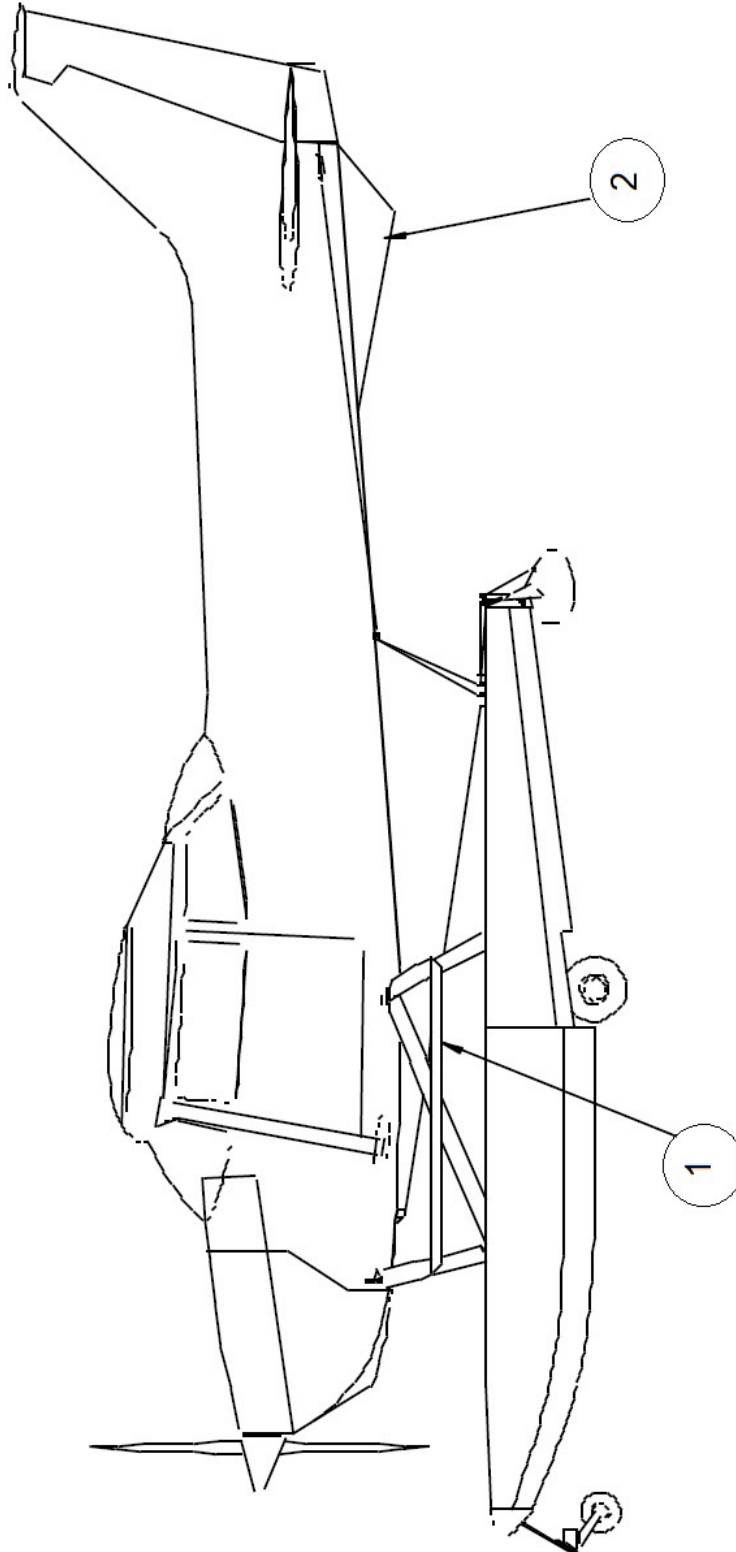

ITEM	QTY	PART NO.	PART DESCRIPTION
1	2	21A02369-035	STEP – L. & R.
	4	AN3-20A	BOLT, 10-32, 1.625 GRIP, UNDRILLED, STEEL
	2	AN3-24A	BOLT, 10-32 THREAD, 2-1/8" GRIP, 2-17/32" LENGTH
	12	NAS1149D0363J	WASHER, 0.203 ID, 0.063 THK, ALUMINUM
	6	MS21044N3	NUT, LOCKING, REGULAR HEIGHT, 10-32 UNF
	6	BPF	HOLE PLUG
	4	6A02273-006	SPACER – FRONT STRUT
2	1	21A12000-042	ASSY. – VENTRAL FIN
	10	B8-75	RIVNUTS
	14	MS21078-08	PLATENUT
	24	AN526-1032R8	SCREW, TRUSS HEAD, NON STRUCTURAL, CAD 1, STEEL
	24	NAS1149D0363J	WASHER, 0.203 ID, 0.063 THK, ALUMINUM
	10	MS35333-39	LOCKWASHER, INTERNAL TOOTH, TO FIT DIA #10

SECTION 10

HYDRAULIC SYSTEM

CONTENTS

HYDRAULIC SYSTEM INSTALLATION POST SERVICE LETTER 228.....	94
HYDRAULIC SYSTEM INSTALLATION PRE SERVICE LETTER 228	97
HYDRAULIC PUMP ASSEMBLY POST SERVICE LETTER 228	100
HYDRAULIC PUMP ASSEMBLY PRE SERVICE LETTER 228	104
HYDRAULIC PUMP OVERVIEW POST SERVICE LETTER 228.....	107
HYDRAULIC PUMP OVERVIEW PRE SERVICE LETTER 228	109
HYDRAULIC SCHEMATIC	111

HYDRAULIC SYSTEM INSTALLATION POST SERVICE LETTER 228

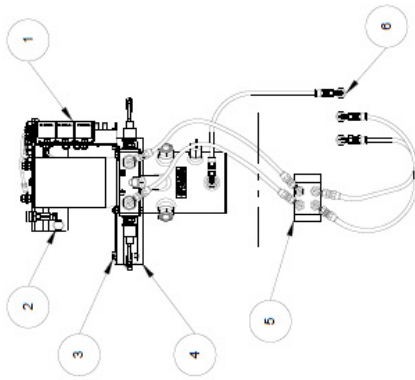

VIEW A
INSTALLATION-HYDRAULIC PUMP LOCATED ON FWD SIDE
FIREWALL (RIGHT SIDE)

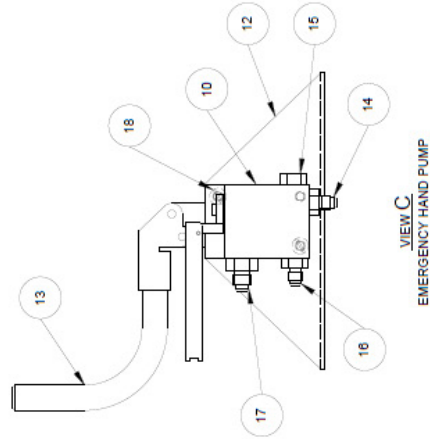

VIEW C
EMERGENCY HAND PUMP

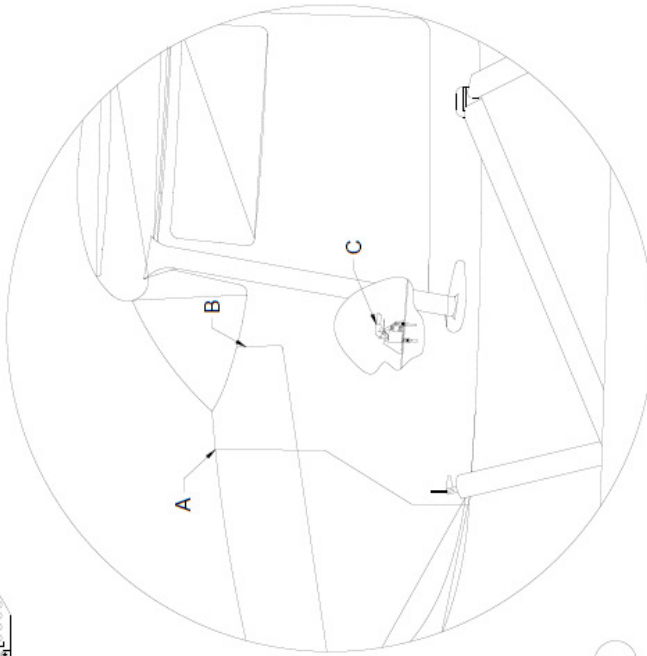

VIEW B
INSTR. PANEL (INDICATOR-GEAR CONTROL)

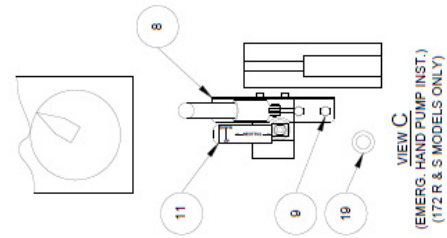
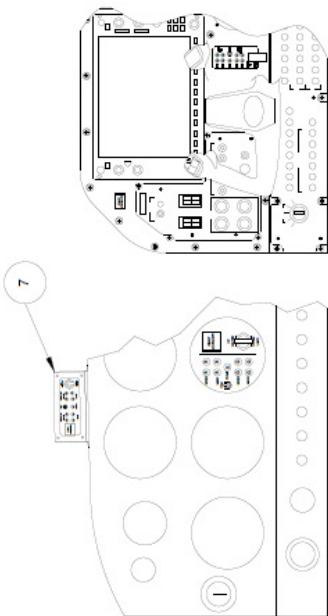

VIEW C
EMERG. HAND PUMP INST.
(172 R & S MODELS ONLY)

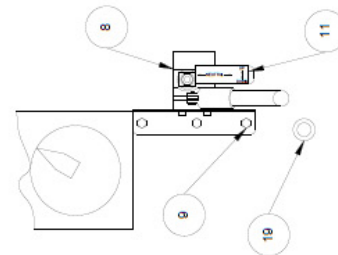

VIEW C
EMERG. HAND PUMP INST.

PARTS MANUAL
2100 FLOATS ON CESSNA 172 & 175

ITEM	QTY	PART NO.	PART DESCRIPTION
1	1	1011849	ASSEMBLY, HYDRAULIC POWER PACK, 12V
	1	1011850	ASSEMBLY, HYDRAULIC POWER PACK, 24V
	1	1011851	SPACER, INSTALLATION, HYDRAULIC POWER PACK
2	2	AN3-3A	(TOP BRACKET) BOLT, 10-32, 0.063 GRIP, UNDRILLED, STEEL
	4	NAS1149F0332P	WASHER, 0.203 ID, 0.032 THK, STEEL
	2	MS21044N3	NUT, LOCKING, REGULAR HEIGHT, 10-32 UNF
3	2	AN4-6A	(BOTTOM BRACKET) BOLT, 1/4-28, 0.313 GRIP, UNDRILLED, STEEL
	4	NAS1149F0432P	WASHER, 0.265 ID, 0.032 THK, STEEL
	2	MS21044N4	NUT, LOCKING, REGULAR HEIGHT, 1/4-28 UNF
4	1	21A09348-020	ANGLE, LOWER PUMP ATTACH
	4	AN3-4A	BOLT, 10-32, 0.125 GRIP, UNDRILLED, STEEL
	4	NAS1149F0363P	WASHER, 0.203 ID, 0.063 THK, STEEL
	4	MS21044N3	NUT, LOCKING, REGULAR HEIGHT, 10-32 UNF
5	1	21A09000-240	ASSEMBLY, MANIFOLD
	1	6A09046-001	MANIFOLD
	2	AN3-5A	BOLT, 10-32, 0.25 GRIP, UNDRILLED, STEEL
	4	AN816-4D	FITTING, NIPPLE, FLARED TUBE AND PIPE THREAD
	4	AN816-4-4D	FITTING, NIPPLE, FLARED TUBE AND PIPE THREAD
	2	NAS1149F0363P	WASHER, 0.203 ID, 0.063 THK, STEEL
	2	MS21044N3	NUT, LOCKING, REGULAR HEIGHT, 10-32 UNF
6	3	AN832-4D	UNION, BULKHEAD, FLARED TUBE
	3	NAS1149F0763P	WASHER, 0.453 ID, 0.063 THK, STEEL
	3	AN924-4D	NUT, TUBE, 7/16-20 THREAD
7	1	21A11158-194	COVER, SQUARE GEAR CONTROL HEAD
	4	MS35214-42	(GEAR CONTROL HEAD MOUNTING SCREWS) SCREW, 8-32, 0.50 LENGTH
8	1	21A09000-194	ASSEMBLY, EMERGENCY HAND PUMP
9	3	AN3-4A	(HAND PUMP MOUNTING HARDWARE) BOLT, 10-32, 0.125 GRIP, UNDRILLED, STEEL
	3	NAS1149F0332P	WASHER, 0.203 ID, 0.032 THK, STEEL
	3	AN970-3	WASHER, 0.203 ID, 0.875 OD, .063 THK, STEEL
	3	MS21044N3	NUT, LOCKING, REGULAR HEIGHT, 10-32 UNF
10	1	642873	HAND PUMP (ONLY)
11	1	12A3-7379-1	PLACARD, EMERGENCY HAND PUMP
12	1	21A09156-129	BRACKET, PUMP ATTACH
13	1	21A09396-001	HANDLE
	1	9283K13	CAP PLUG
14	1	21A09746-001	UNION
	1	MS28775-012	O-RING, HYDRAULIC PACKING, 0.364 ID
15	1	AN814-4D	PLUG, 7/16-20 THREAD
	1	MS28775-012	O-RING, HYDRAULIC PACKING, 0.364 ID

ITEM	QTY	PART NO.	PART DESCRIPTION
16	1	AN815-4D	UNION
	1	MS28775-012	O-RING, HYDRAULIC PACKING, 0.364 ID
17	1	AN919-6D	UNION
	1	MS28775-014	O-RING, HYDRAULIC PACKING, 0.489 ID
18	2	MS16997-77	SOCKET HEAD CAP SCREW, 5/16-18 THREAD
	2	MS35333-41	LOCK WASHER, INTERNAL TOOTH
	2	NAS1149F0563P	WASHER, 0.328 ID, 0.063 THK, STEEL
19	1	MS35489-49	GROMMET
20	2	21A04000-080	ASSEMBLY, BRAKE LINE (NOT SHOWN)
	2	63-190600-3	FITTING, AERO QUIP HOSE #3

HYDRAULIC SYSTEM INSTALLATION PRE SERVICE LETTER 228

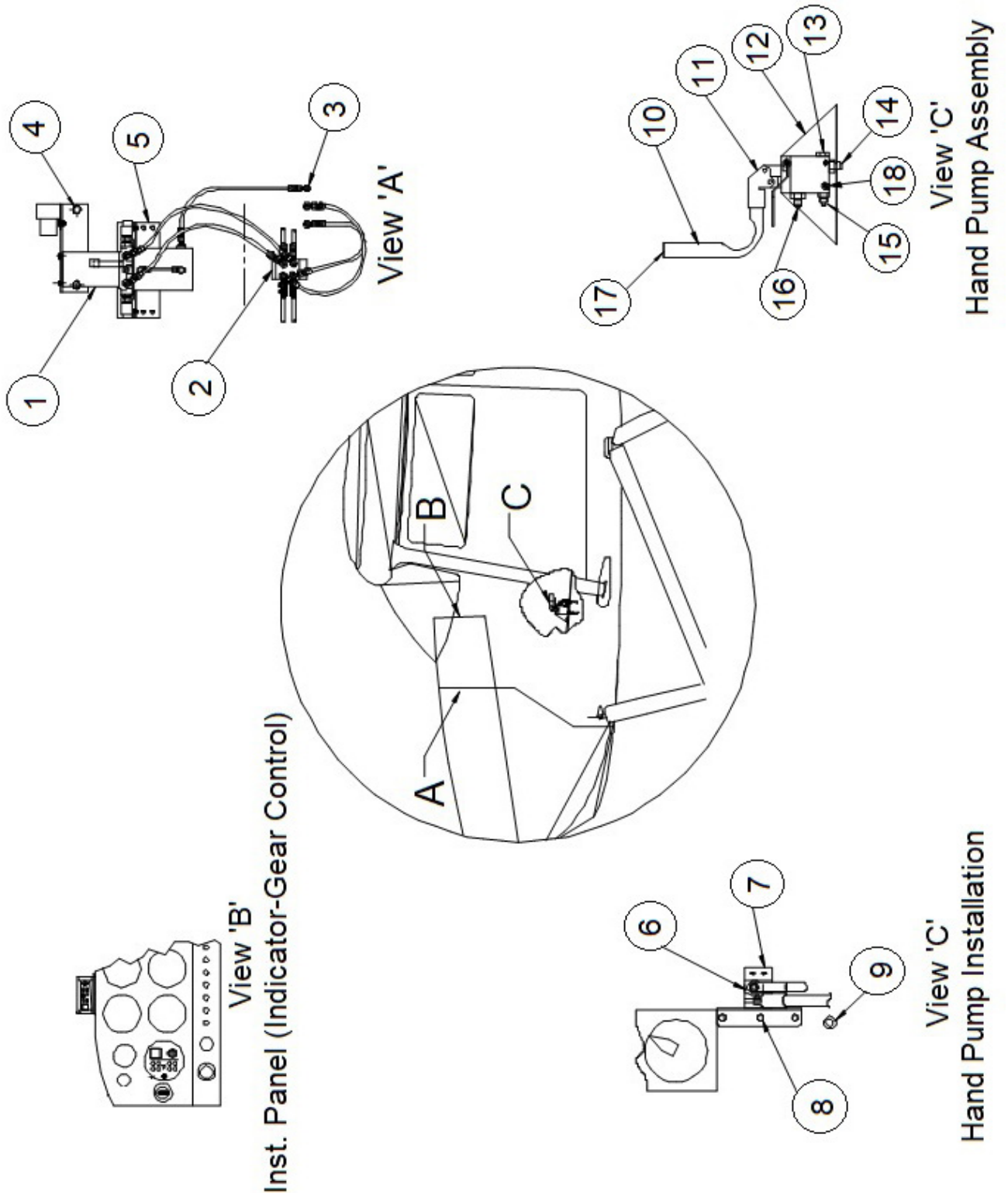

ITEM	QTY	PART NO.	PART DESCRIPTION
1	1	21A09000-239	ASSY. - HYD PUMP 12V
	1	21A09000-283	ASSY. - HYD PUMP 24V
2	1	21A09000-240	ASSY. - MANIFOLD
	1	6A09046-001	MANIFOLD
	4	AN816-4-4D	NIPPLE - FITTING
	2	AN3-5A	BOLT, 10-32, 0.25 GRIP, UNDRILLED, STEEL
	2	NAS1149F0363P	WASHER, 0.203 ID, 0.063 THK, STEEL
	2	MS21044N3	NUT, LOCKING, REGULAR HEIGHT, 10-32 UNF
	4	AN815-4D	NIPPLE - FITTING
3	3	AN832-4D	UNION - FIREWALL
	3	NAS1149F0763P	WASHER, 0.453 ID, 0.063 THK, STEEL
	3	AN924-4D	NUT, TUBE, 7/16-20 THREAD
4	2	AN3-4A	BOLT - TOP BRACKET ATTACH
	4	NAS1149D0363J	WASHER, 0.203 ID, 0.063 THK, ALUMINUM
5	1	21A09348-020	ANGLE - LOWER PUMP ATTACH
	4	AN3-4A	BOLT, 10-32, 0.125 GRIP, UNDRILLED, STEEL
	4	NAS1149D0363J	WASHER, 0.203 ID, 0.063 THK, ALUMINUM
	4	MS21044N3	NUT, LOCKING, REGULAR HEIGHT, 10-32 UNF
6	1	21A09000-194	ASSY. - HAND PUMP
7	1	21A09000-265	ASSY. - PLACARD
8	3	AN3-4A	BOLT, 10-32, 0.125 GRIP, UNDRILLED, STEEL
	3	AN970-3	WASHER, .203 ID, .875 OD, .063 THK
	3	NAS1149D0363J	WASHER, 0.203 ID, 0.063 THK, ALUMINUM
	3	MS21044N3	NUT, LOCKING, REGULAR HEIGHT, 10-32 UNF
9	1	MS35489-49	GROMMET
10	1	21A09396-001	HANDLE
11	1	642873	HAND PUMP (ONLY)
12	1	21A09156-129	BRACKET - PUMP ATTACH
13	1	AN814-4D	PLUG
	1	MS28775-012	O RING, HYDRAULIC PACKING, .364 ID
14	1	21A09746-001	UNION
	1	MS28775-012	O RING, HYDRAULIC PACKING, .364 ID
15	1	AN815-4D	UNION
	1	MS28775-012	O RING, HYDRAULIC PACKING, .364 ID
16	1	AN919-6D	UNION
	1	MS28775-014	"O" RING, HYDRAULIC
17	1	9283K13	CAP PLUG
18	2	5/16-18 UNC-28 X .63	CAP SCREW - ATTACH
	2	MS35333-40	LOCKWASHER, INTERNAL TOOTH, TO FIT DIA 1/4"
	2	NAS1149F0563P	WASHER, 0.328 ID, 0.063 THK, STEEL

PARTS MANUAL
2100 FLOATS ON CESSNA 172 & 175

ITEM	QTY	PART NO.	PART DESCRIPTION
19	2	21A04000-080	ASSY. – BRAKE LINE (NOT SHOWN)
	2	63-190600-3	FITTING, AERO QUIP HOSE #3

HYDRAULIC PUMP ASSEMBLY POST SERVICE LETTER 228

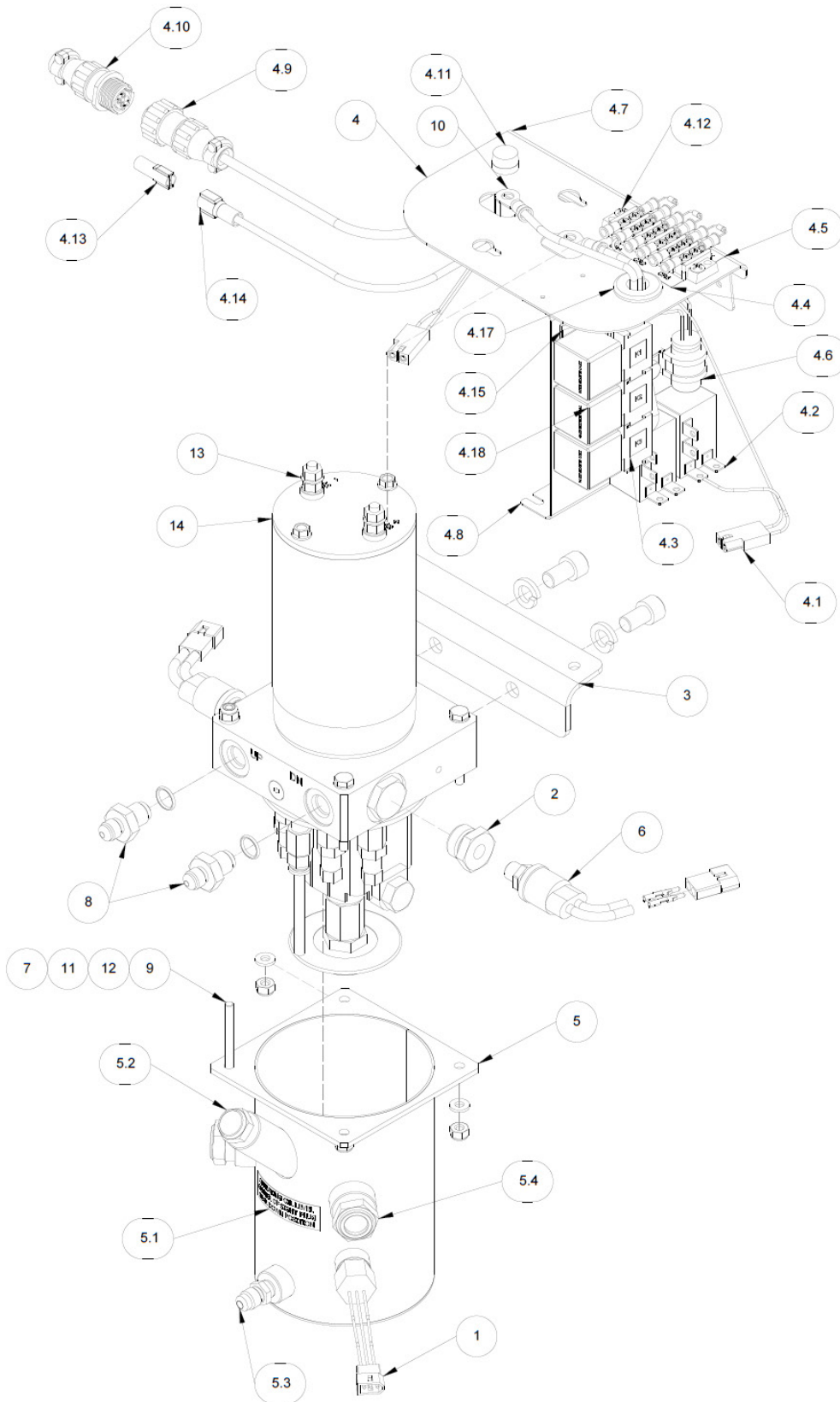

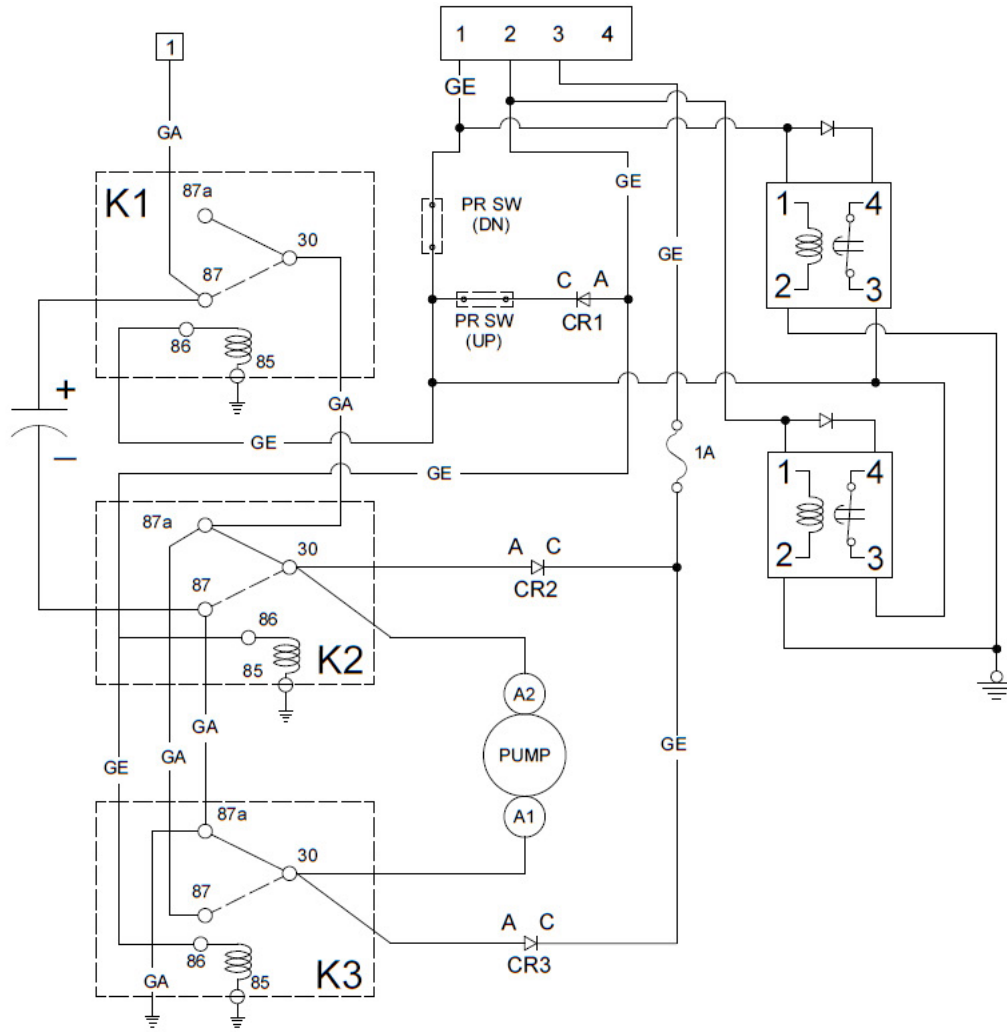

POWER PACK SCHEMATIC
 (RELAYS SHOWN IN RELAXED CONDITION)

- 1. GE WIRES 20 GA
- 2. GA WIRES 12 GA

ITEM	QTY	PART NO.	PART DESCRIPTION
-	1	1011849	ASSEMBLY, HYDRAULIC POWER PACK, 12V
-	1	1011850	ASSEMBLY, HYDRAULIC POWER PACK, 24V
1	1	1009428	ASSEMBLY, SENSOR, FLUID LEVEL
	1	93786A200	PRESSURE SEALING WSHER, M12
2	2	1011062	ASSEMBLY, PLUG, PRESSURE SWITCH PORT
3	1	1011842	ANGLE, MOUNTING HYDRAULIC PUMP
	2	MS16997-96	SOCKET HEAD CAP SCREW, 3/8-16 THREAD
	2	MS35338-46	WASHER, SPLIT
4	1	1011845	ASSEMBLY, SUPPORT PLATE, HYDRAULIC POWER PACK, 12V
	1	1011846	ASSEMBLY, SUPPORT PLATE, HYDRAULIC POWER PACK, 24V
4.1	2	03-09-1022	CONNECTOR PLUG, MALE, 2 CONN.
	4	02-09-1104	PIN, CRIMP FEMALE, 1/8" DIA
4.2	1	1005042	TIMER RELAY HARNESS, 12VDC
	1	1005043	TIMER RELAY HARNESS, 24VDC
4.3	1	1009143-01	PLACARD, K1 INDICATOR
	1	1009143-02	PLACARD, K2 INDICATOR
	1	1009143-03	PLACARD, K3 INDICATOR
4.4	1	1009144-01	PLACARD, CR INDICATOR
4.5	1	1009144-02	PLACARD, AC INDICATOR
4.6	1	1011798	ASSEMBLY, CAPACITOR
	1	MS21919WDG10	CLAMP, LOOP, CUSHIONED, 5/8" TUBE OD
	1	AN3-3A	BOLT, 10-32, 0.063 GRIP, UNDRILLED, STEEL
	1	NAS1149F0332P	WASHER, 0.203 ID, 0.032 THK, STEEL
	1	MS21044N3	NUT, LOCKING, REGULAR HEIGHT, 10-32 UNF
4.7	1	1011843	TOP PLATE, HYDRAULIC PUMP
4.8	1	1011844	ELECTRONIC SIDE PLATE
4.9	1	206429-1	PLUG, MALE, CPC SIZE 1, 4 PIN
	3	66103-4	PIN, CRIMP SOCKET, 24-20 AWG
	1	206062-3	CLAMP, CABLE, CPC SIZE 11
4.10	1	206430-2	PLUG, FEMALE, CPC SIZE 1, 4 PIN
	3	66105-4	CRIMP SOCKET, FEMALE
	1	206062-3	CLAMP, CABLE, CPC SIZE 11
4.11	1	3453LF2A	FUSE HOLDER
	1	AGC-1	FUSE, 250V, 1 AMP
4.12	1	6-140	TERMINAL BLOCK, 6 CONNECTOR
	2	AN526C632R8	SCREW, MACHINE, TRUSS HEAD, 6-32 THREAD
	2	MS21044N06	NUT LOCKING, REGULAR HEIGHT, 6-32 UNC
	12	MS25036-102	RING TERMINAL, #6 STUD, 16-22 AWG, RED
	3	1N4004	DIODE
4.13	1	73F-250-32-NL	CONNECTOR, FEMALE, 10-12 AWG, FULLY INSULATED
4.14	1	73M-250-32-NL	CONNECTOR, MALE, 10-12 AWG, FULLY INSULATED

PARTS MANUAL
2100 FLOATS ON CESSNA 172 & 175

ITEM	QTY	PART NO.	PART DESCRIPTION
4.15	3	BR05-FW	SOCKET, 5 PRING, PLASTIC
	14	1-901-355-917	TERMINAL
	3	AN3-3A	BOLT, 10-32, 0.063 GRIP, UNDRILLED, STEEL
	6	NAS1149F0332P	WASHER, 0.203 ID, 0.032 THK, STEEL
	3	MS21044N3	NUT, LOCKING, REGULAR HEIGHT, 10-32 UNC
4.16	1	MS35489-9	GROMMET, RUBBER (NOT SHOWN)
4.17	1	MS35489-14	GROMMET, RUBBER
4.18	3	V23234- A0001-X032	RELAY, PRONG, 12V
	3	0-332-209-211	RELAY, 5 PRONG, 24V
5	1	1011847	ASSEMBLY, HYDRAULIC RESERVOIR
5.1	1	1011848	PLACARD, OIL LEVEL
5.2	1	1EJT7	BREATHER VENT
5.3	1	AN816-4D	NIPPLE, FLARED TUBE AND PIPE THREAD
5.4	2	LSP151-04-01	LIQUID LEVEL SIGHT PLUG
6	1	20PS001EB700 W50OW	PRESSURE SWITCH
	2	03-09-2022	CONNECTOR, PLUG, FEMALE
	4	02-09-2118	PIN, CRIMP MALE, 1/8" DIA.
7	4	AN3-16A	BOLT, 10-32, 1.375 GRIP, UNDRILLED, STEEL
8	2	AN919-3D	FITTING, REDUCER
	2	MS28775-013	O-RING, HYDRAULIC
9	4	MS21044N3	NUT, LOCKING, REGULAR HEIGHT, 10-32 UNF
10	2	MS25036-157	RING TERMINAL, 1/4 STUD, 10-12 AWG, YELLOW
11	2	NAS1149F0332P	WASHER, 0.203 ID., 0.032 THK, STEEL
12	5	NAS1149F0363P	WASHER, 0.203 ID, 0.063 THK, STEEL
13	2	NAS1149F0432P	WASHER, 0.265 ID, 0.032 THK, STEEL
14	1	YBZS- C0.63W1T100K/ UVZOT2	HYDRAULIC PUMP, 12VDC
	1	YBZS- C0.63W2T100K/ UVZOT2	HYDRAULIC PUMP, 24VDC

HYDRAULIC PUMP ASSEMBLY PRE SERVICE LETTER 228

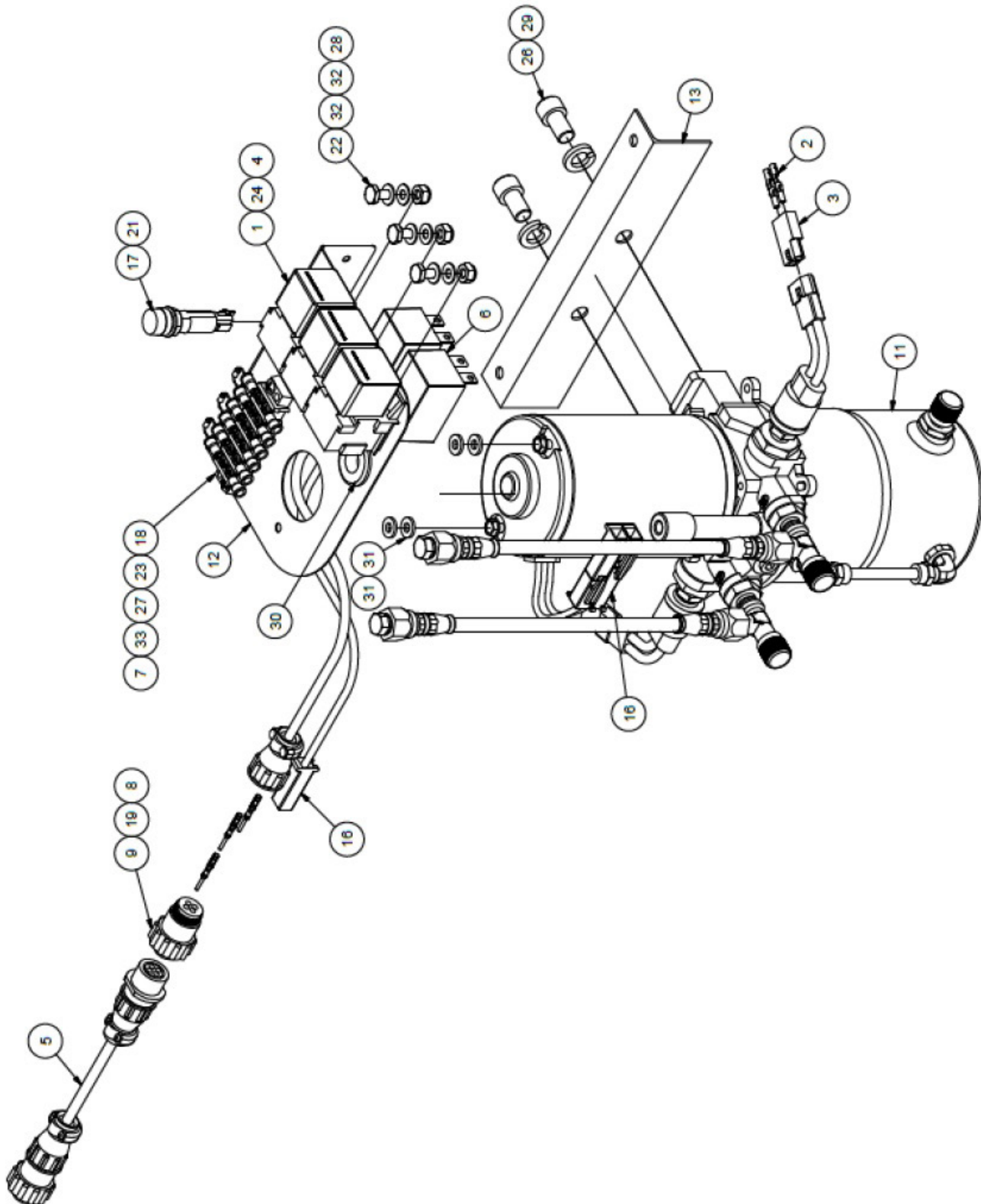

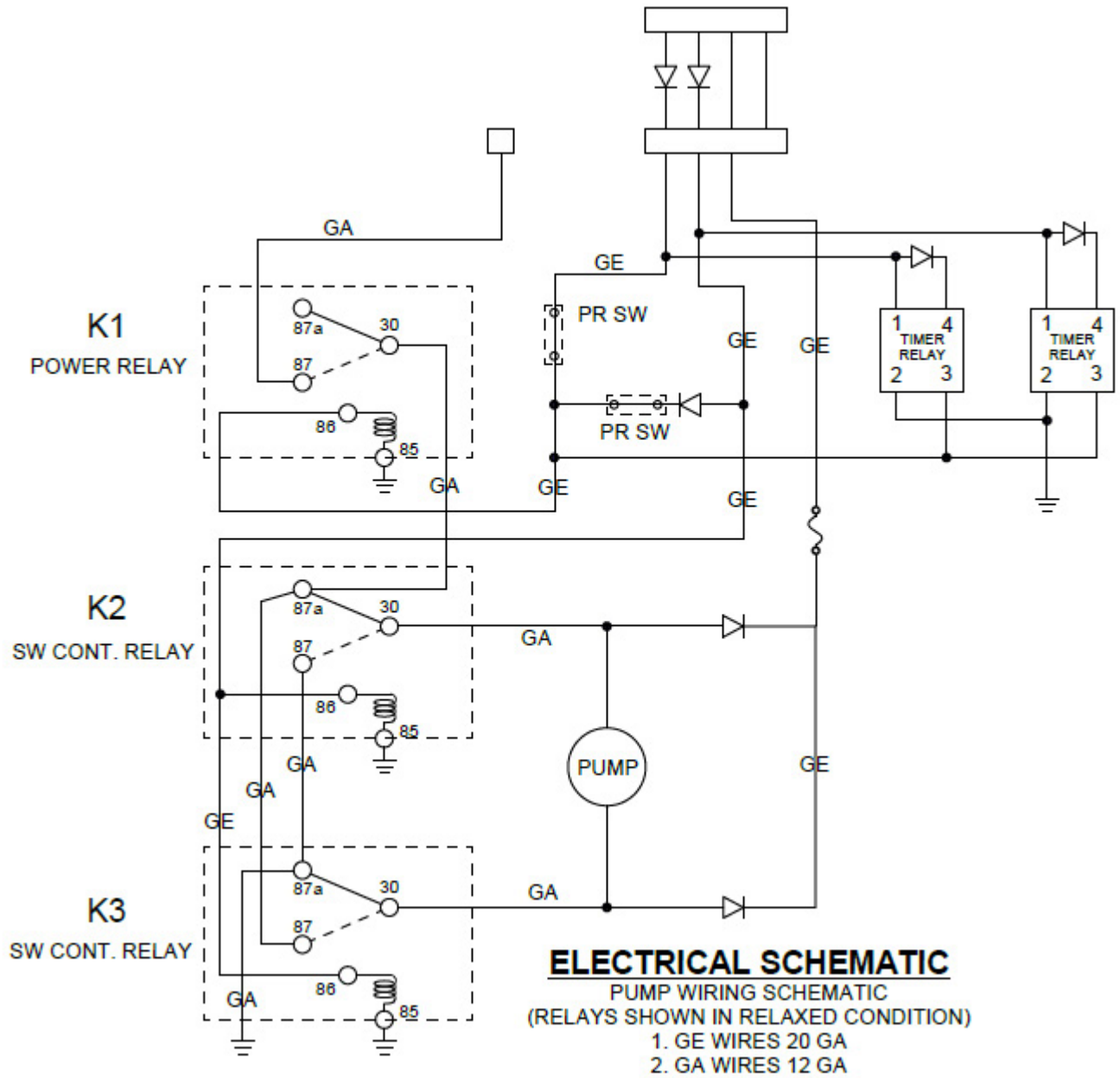

ITEM	QTY	PART NO.	PART DESCRIPTION
1	3	0-332-209-137	RELAY, 12V, 5 PRONG
	3	0-332-209-211	RELAY, 24V, 5 PRONG
2	4	02-09-1104	PIN, CRIMP FEMALE, 1/8" DIA
3	2	03-09-1022	CONNECTOR PLUG, MALE, 2 CONN.
4	14	1-901-355-917	TERMINAL
5	1	1004949	CABLE, DIODE ADAPTOR
6	1	1005042	TIMER RELAY HARNESS
7	3	1N4004	DIODE, 2-1/2"
8	2	206062-3	CLAMP, CABLE, CPC SIZE 11
9	1	206429-1	PLUG, MALE, CPC SIZE 1, 4 PIN
10	1	206430-2	CPC FREE HANG, 4 PIN, FEMALE
11	1	21A09000-215	ASSEMBLY, HYDRAULIC PUMP, 12V
	1	21A09000-282	ASSEMBLY, HYDRAULIC PUMP, 24V
12	1	21A09005-264	SUPPORT, HYD. PUMP ATTCH
13	1	21A09352-030	ANGLE, MOUNTING, HYD. PUMP
14	6 FT	22759-16-12-9	WIRE, 12 AWG, WHITE
15	10.1 FT	22759-16-20-9	WIRE, 20 AWG, WHITE
16	1	73F-250-32-NL	CONNECTOR, FEMALE, 10-12 AWG
	1	73M-250-32-NL	CONNECTOR, MALE, 10-12 AWG
17	1	3453LF2A	FUSE HOLDER
18	1	6-140	TERMINAL BLOCK, 6 CONNECTOR
19	3	66103-4	PIN, CRIMP SOCKET, 24-20G
20	3	66105-4	CRIMP SOCKET, FEMALE
21	1	AGC-1	FUSE, 250V, (S2565-1)
22	3	AN3-3A	BOLT, 10-32, 0.0625 GRIP, UNDRILLED, STEEL
23	2	AN526-632R8	SCREW, TRUSS HEAD MACHINE, 6-32 THREAD, 1/2" LENGTH
24	3	BR05FW	SOCKET, 5 PRONG, PLASTIC
25	1.5 FT	HS105-3/16-0	HEAT SHRINK, TUBING, BLACK
26	2	MS16997-96	SOCKET HEAD CAP SXREW
27	2	MS21044N06	NUT, LOCKING, REGULAR HEIGHT, 6-32 UNC
28	3	MS21044N3	NUT, LOCKING, REGULAR HEIGHT, 10-32 UNF
29	2	MS35338-46	WASHER, SPLIT, CARBON STEEL
30	1	MS35489-14	GROMMET, RUBBER
31	4	NAS1149D0363J	WASHER, 0.203 ID, 0.063 THK, ALUMINUM
32	6	NAS1149F0332P	WASHER, 0.203 ID, 0.032 THK, STEEL
33	12	R-3	RING CONNECTOR

HYDRAULIC PUMP OVERVIEW POST SERVICE LETTER 228

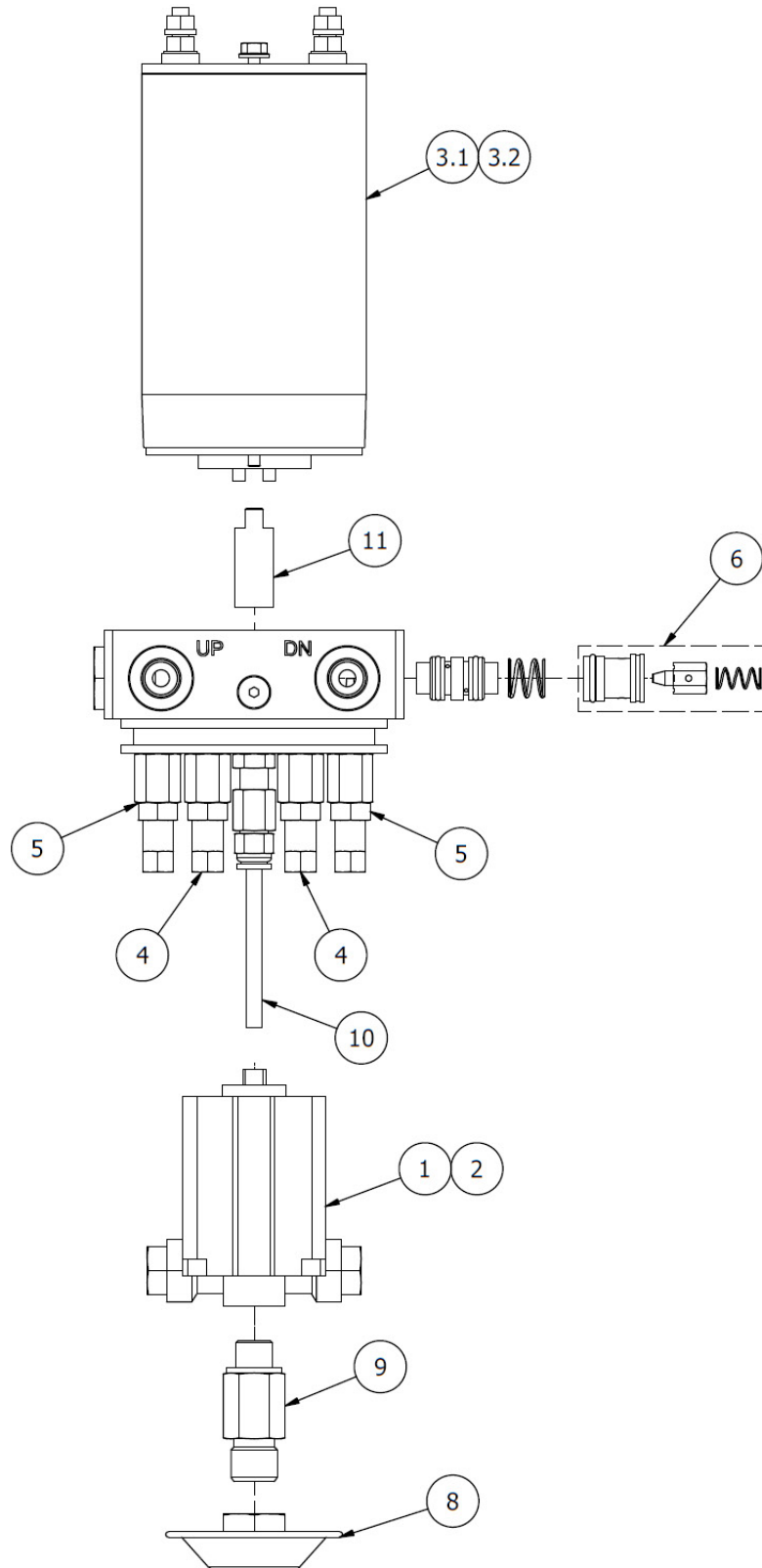

ITEM	QTY	PART NO.	PART DESCRIPTION
1	1	202-0003	BI-DIRECTIONAL PUMP, 0.64 ML/R
2	1	299-0008	SEAL KIT, BI-DIRECTIONAL GEAR PUMP
3.1	1	610-0010	DC MOTOR, 12V, .8KW
3.2	1	610-0017	DC MOTOR, 24V, .8KW
4	2	631-0005	PRESSURE RELIEF VALVE
5	2	631-0006	THERMAL RELIEF VALVE
6	2	632-0004	ASSEMBLY, PILOT OPERATED CHECK VALVE
7	1	637-0024	SHUTTLE VALVE
8	1	682-0019	FILTER, PICKUP TUBE, HYDRAULIC PUMP
9	1	682-0055	SUCTION HEX TUBE
10	1	682-0056	RETURN TUBE
11	1	683-0011	COUPLING, MOTOR TO PUMP
12	2	685-0012	SPRING, SHUTTLE VALVE
13	1	687-0001	SEAL KIT, RESERVIOR O-RING, PILOT OPERATED RELIEF VALVE O-RING, THERMAL AND PRESSURE RELIEF VALVE O-RING (NOT SHOWN)

HYDRAULIC PUMP OVERVIEW PRE SERVICE LETTER 228

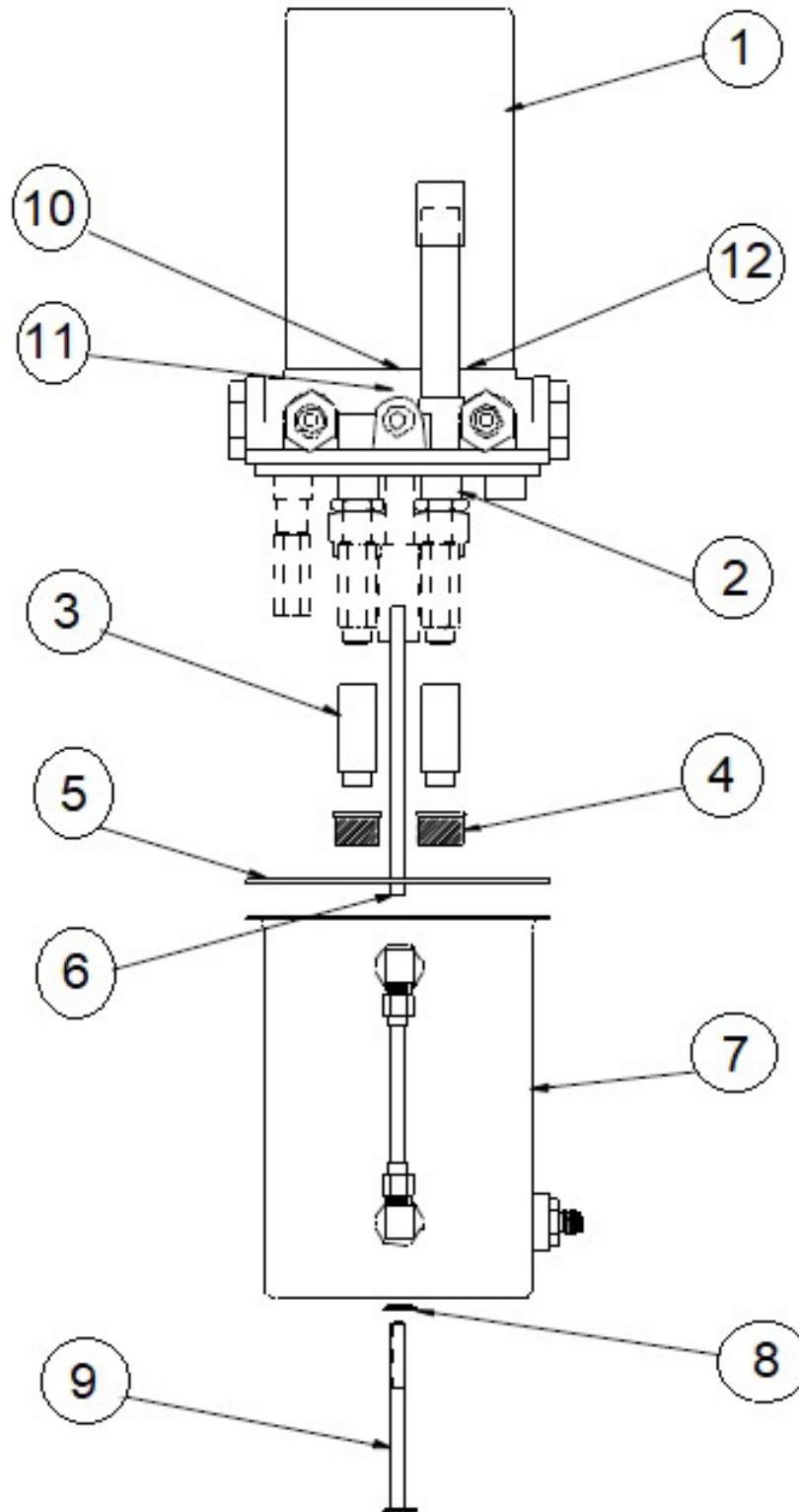

ITEM	QTY	PART NO.	PART DESCRIPTION
1	1	21A09000-215	HYDRAULIC PUMP ASSY. (12V)
	1	21A09000-282	HYDRAULIC PUMP ASSY. (24V)
	1	640661	MOTOR (12V)
	1	641131	MOTOR (24V)
2	1	634873	BASIC PUMP
3	2	362136	TUBE EXTENSIONS
4	2	410521*	FILTER
5	1	410578*	SEAL RESERVIOR
6	1	365047	RETURN TUBE
7	1	775260	RESERVIOR – GAUGE ASSY.
8	1	415067	SEAL THREAD
9	1	409715*	SCREW – RESERVIOR ATTACH
10	1	361183*	COUPLING – MOTOR TO PUMP
11	1	410512	SEAL – PUMP SHAFT
12	1	405673	O-RING, BI-DIRECTIONAL MOTOR TO ADAPTOR

* Reference Wipaire drawing 1011065 for alternate part numbers.

HYDRAULIC SCHEMATIC

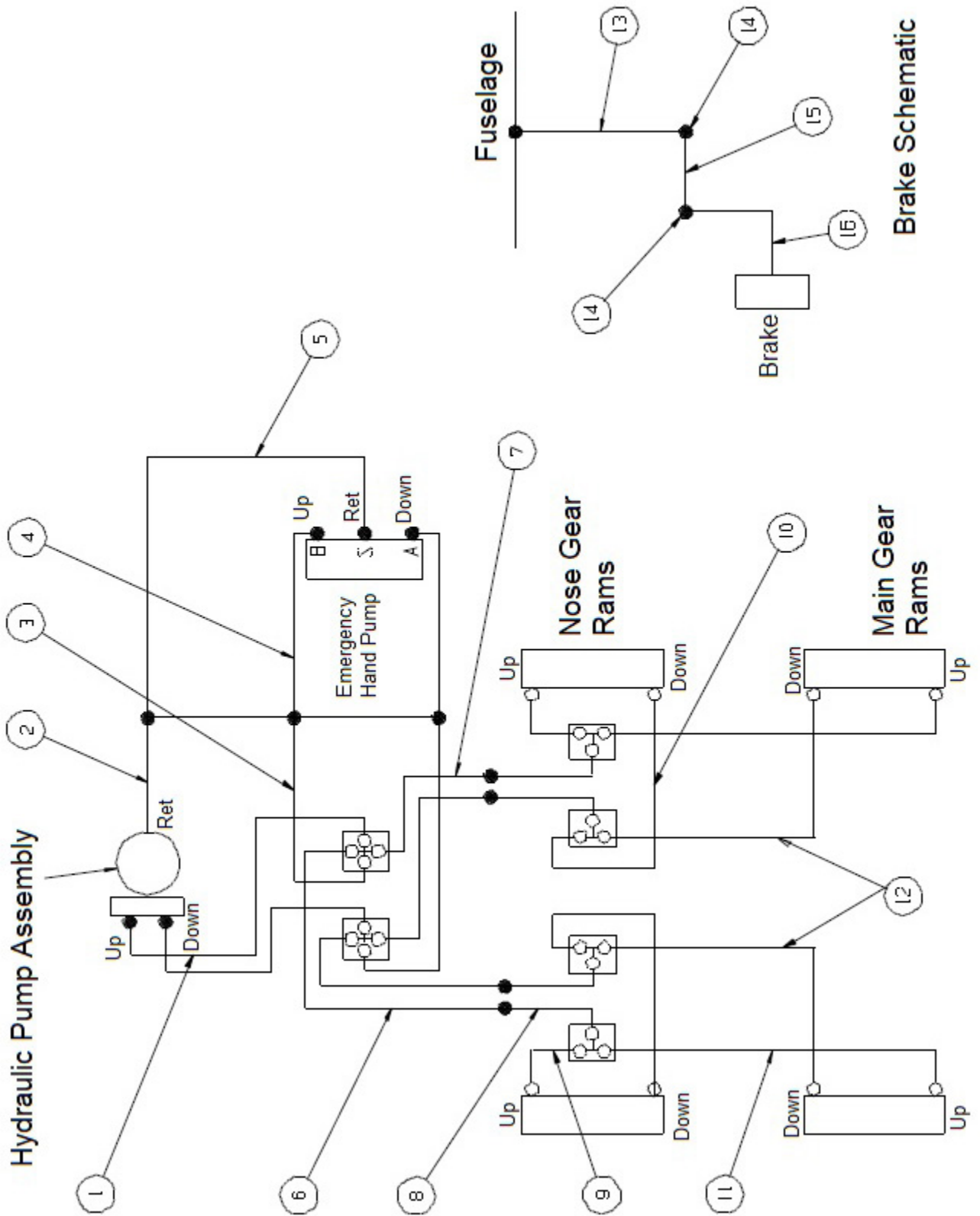

ITEM	QTY	PART NO.	PART DESCRIPTION
1	2	21A09000-197	ASSY, HOSE, MAIN PUMP TO MANIFOLD, 18"
2	1	21A09000-201	ASSY, HOSE, LWR RES FITTING TO FW, 18"
3	2	21A09000-200	ASSY, HOSE, FIREWALL TO MANIFOLD, 8"
4	2	21A09000-202	ASSY, HOSE, FIREWALL TO HAND PUMP, 60"
5	1	21A09000-203	ASSY, HOSE, FIREWALL TO HAND PUMP 40"
6	2	21A09000-198	ASSY, HOSE, LH FLOAT TO MANIFOLD 74"
7	2	21A09000-199	ASSY, HOSE RH FLOAT TO MANIFOLD 62"
8	4	21A09000-222	ASSEMBLY, HOSE – TEE TO TOP UP – DN
9	2	21A09000-218	ASSEMBLY, HOSE – NOSE UP TO TEE
10	2	21A09000-219	ASSEMBLY, HOSE – NOSE DN TO TEE
11	2	21A09000-220	ASSEMBLY, HOSE – MAIN UP TO TEE
12	2	21A09000-221	ASSEMBLY, HOSE – MAIN DN TO TEE
13	2	21A09000-080	ASSY. – HYDRAULIC HOSE
	2	63-190600-3	FITTING – ENDS
14	2	AN833-3D	FITTING – ELBOW
	4	NAS1149D0663J	WASHER, 0.39 ID, 0.063 THK, ALUMINUM
	2	AN924-3D	NUT, TUBE, 3/8-24 THREAD
15	2	21A04000-079	LINE ASSY. – HARD
16	2	21A04000-078	LINE ASSY. – FLEX

SECTION 11

ELECTRICAL

CONTENTS

ELECTRICAL SCHEMATIC POST SERVICE LETTER 228	114
ELECTRICAL SCHEMATIC PRE SERVICE LETTER 228.....	116
GEAR CONTROL (ROUND).....	118
GEAR CONTROL (RECTANGLE).....	121
GEAR CONTROL (G1000 ONLY).....	123

ELECTRICAL SCHEMATIC POST SERVICE LETTER 228

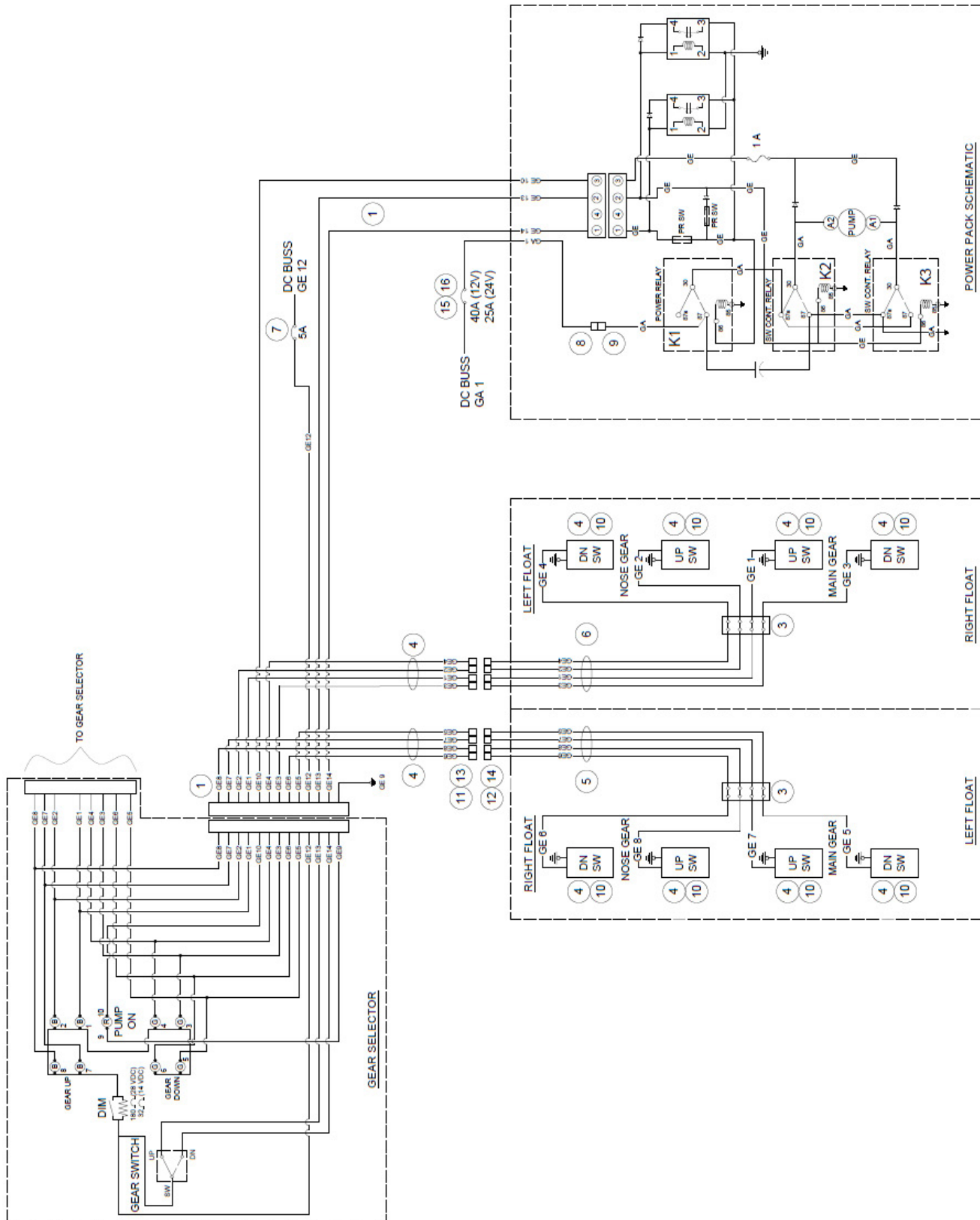

PARTS MANUAL
2100 FLOATS ON CESSNA 172 & 175

ITEM	QTY	PART NO.	PART DESCRIPTION
1	1	4A11000-011	ASSEMBLY, GEAR SELECTOR WIRING HARNESS
2	1	4A11000-014	ASSEMBLY, WIRING HARNESS, GEAR ADVISORY
3	2	4-140	TERMINAL BLOCK, 4 POSITION
4	8	5801	GEAR POSITION SWITCH, PROXIMITY, MAGNETIC
5	1	6A10000-004	WIRE HARNESS, LEFT FLOAT
6	1	6A10000-005	WIRE HARNESS, RIGHT FLOAT
7	1	7277-2-5	CIRCUIT BREAKER, 5 AMP
8	1	73F-250-32-NL	CONNECTOR, FEMALE, 12-10 AWG
9	1	73M-250-32-NL	CONNECTOR, MALE, 12-10 AWG
10	8	21A09005-262	CLIP, GEAR POSITION SWITCH HOLDER
11	8	S1635-1	PIN
12	8	S1636-1	SOCKET
13	8	S1637-1	HOUSING
14	8	S1637-2	HOUSING
15	1	W23-X1A1G-25	CIRCUIT BREAKER, 25 AMP, 24VDC
16	1	W23-X1A1G-40	CIRCUIT BREAKER, 40 AMP, 12VDC

ELECTRICAL SCHEMATIC PRE SERVICE LETTER 228

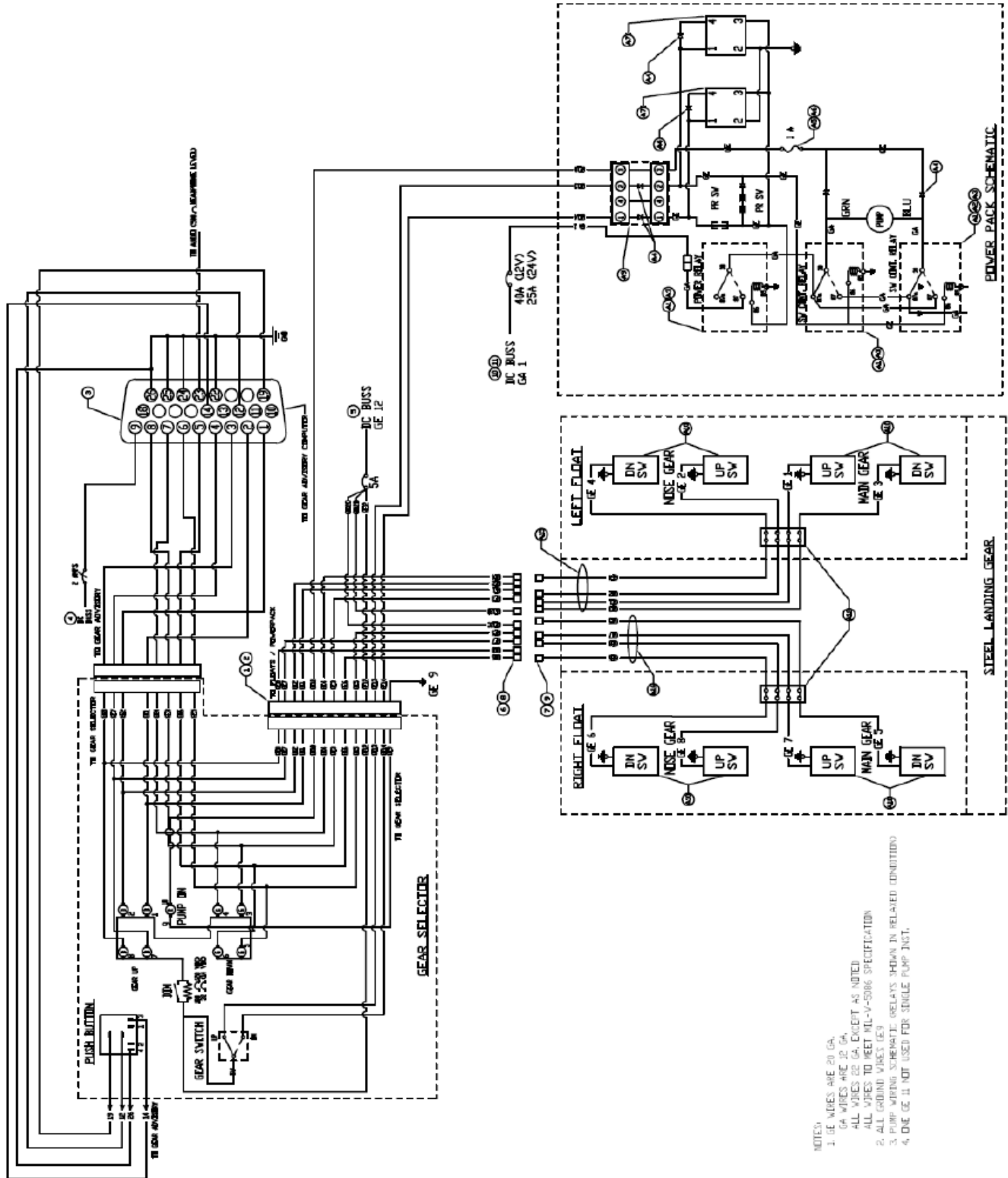

PARTS MANUAL
2100 FLOATS ON CESSNA 172 & 175

ITEM	QTY	PART NO.	PART DESCRIPTION
1	1	4A11000-011	ASSEMBLY, GEAR SELECTOR WIRING HARNESS
3	1	4A11000-014	ASSEMBLY, WIRING HARNESS, GEAR ADVISORY
4	1	7277-2-2	KLIXON CIRCUIT BREAKER, 2 AMP
5	1	7277-2-5	KLIXON CIRCUIT BREAKER, 5 AMP
6	8	S1635-1SF	PIN
7	8	S1636-1	SOCKET
8	8	S1637-1	HOUSING
9	8	S1637-2	HOUSING
10	1	W-23- X1A1G-25	BREAKER, CIRCUIT, 25AMP
11	1	W-23-X1A1G-40	BREAKER, CIRCUIT, 40AMP
A1	3	0-332-209-211	RELAY, 24V, 5 PRONG
A2	3	0-332-209-137	RELAY 24V
A3	3	BR05FW	SOCKET, 5 PRONG, PLASTIC
A4	7	1N4004	DIODE, 2-1/2"
A5	1	AGC-1	FUSE, 250V, (S2565-1)
A6	1	3453LF2A	FUSE HOLDER
A7	2	1005042	ASSEMBLY, TIMER RELAY HARNESS (12V SYSTEM)
A9	1	1004949	CABLE, DIODE ADAPTER
A10	8	5801	SWITCH, SENSOR
A12	2	4-140	4 LUG TERMINAL BLOCK
A15	1	6A10000-004	ASSEMBLY, WIRE HARNESS, LEFT FLOAT
A16	1	6A10000-005	ASSEMBLY, WIRE HARNESS, RIGHT FLOAT

GEAR CONTROL (ROUND)

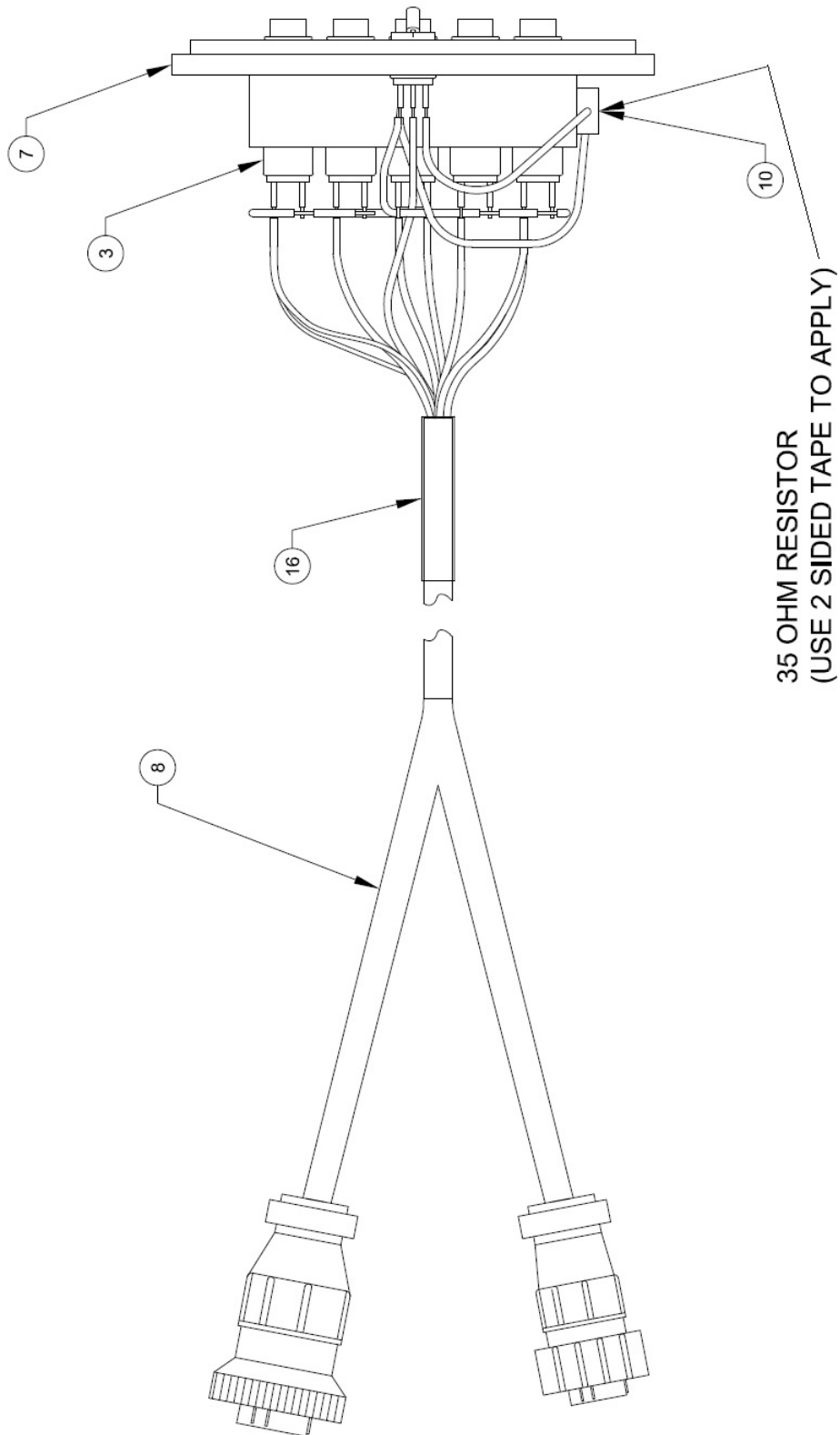

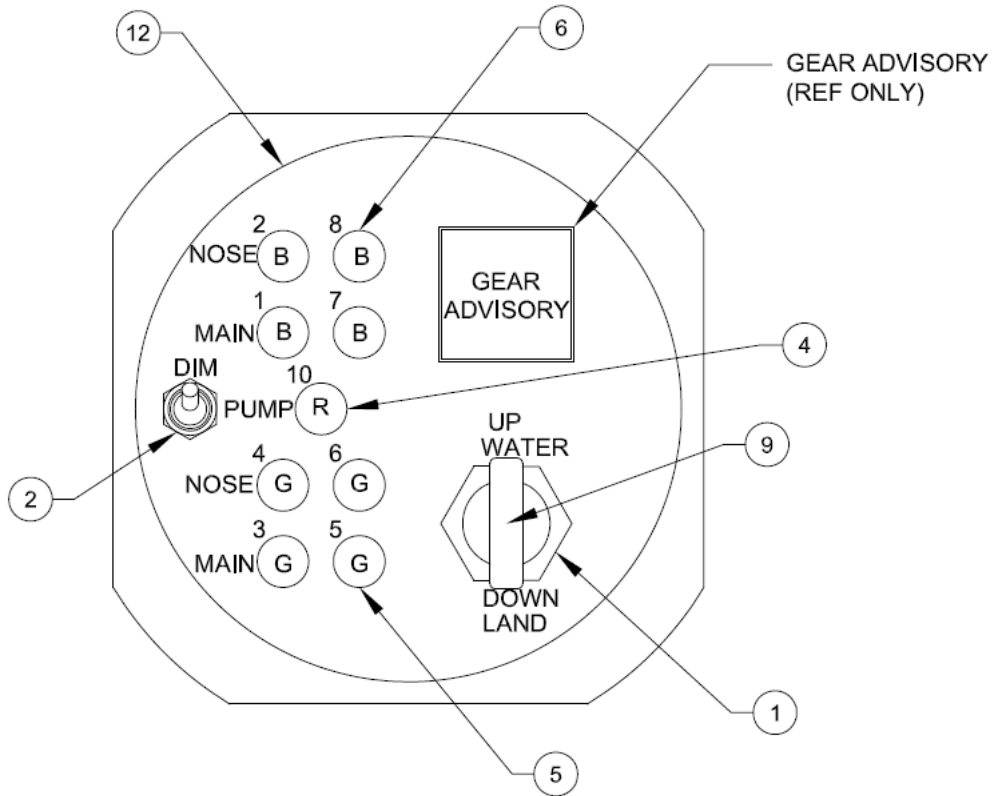
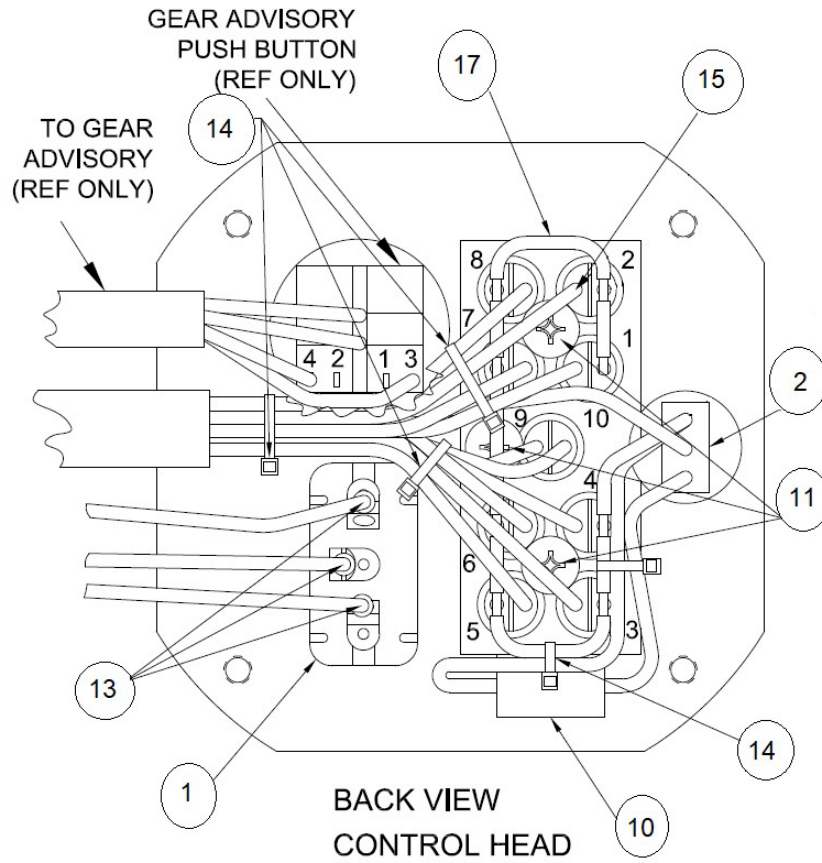

ITEM	QTY	PART NO.	PART DESCRIPTION
-	1	21A11000-009	GEAR SELECTOR ASSY. ROUND (12V)
-	1	21A11000-019	GEAR SELECTOR ASSY. ROUND (24V)
1	1	8857K44	SWITCH
2	1	A101SYCB	TOGGLE SWITCH, SPDT, ON-ON
3	9	515-0012	SOCKET
4	1	507-3914-1431-600F	INDICATOR LAMP, 14V, RED
	1	507-3918-1431-600F	INDICATOR LAMP, 28V, RED
5	4	507-3914-1432-600F	INDICATOR LAMP, 14V, GREEN
	4	507-3918-1432-600F	INDICATOR LAMP, 28V, GREEN
6	4	507-3914-1434-600F	INDICATOR LAMP, 14V, BLUE
	4	507-3918-1434-600F	INDICATOR LAMP, 28V, BLUE
7	1	21A11179-001	BLOCK, GEAR CONTROL
8	1	4A11000-008	HARNESS ASSEMBLY, GEAR SELECTOR
9	1	21A11259-003	GEAR SWITCH KNOB
10	1	RH-5-35	RESISTOR, 14V, DALE RH5 5W
	1	RH-5-180	RESISTOR, 28V, DALE RH5 5W
11	3	AN526-632R8	SCREW, TRUSS HEAD, 6-32
12	1	10B3-6202	PLACARD, ROUND 2100 GEAR SELECTOR
13	3	R-3	RING CONNECTOR, #6, 20 AWG, RED
14	5	PLT1M-M	CABLE TIE
15	16 IN	HIXR-3/16	SHRINK WRAP, 3/16, WHITE
16	3 IN	HS105-1/2-0	HEAT SHRINK TUBING
17	6 IN	22759-16-20-9	WIRE, 20 AWG, WHITE

GEAR CONTROL (RECTANGLE)

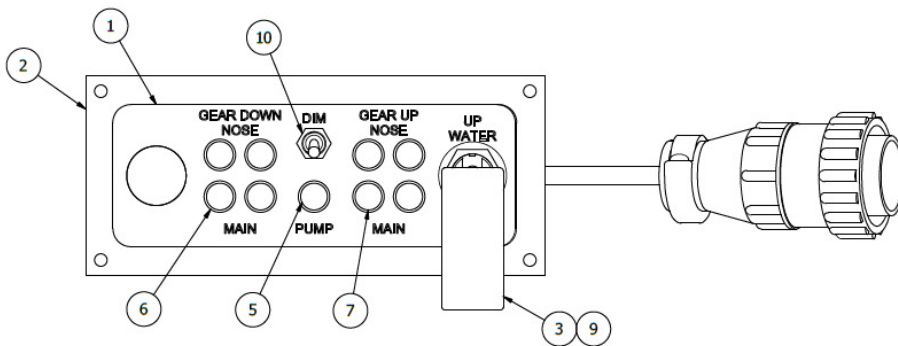
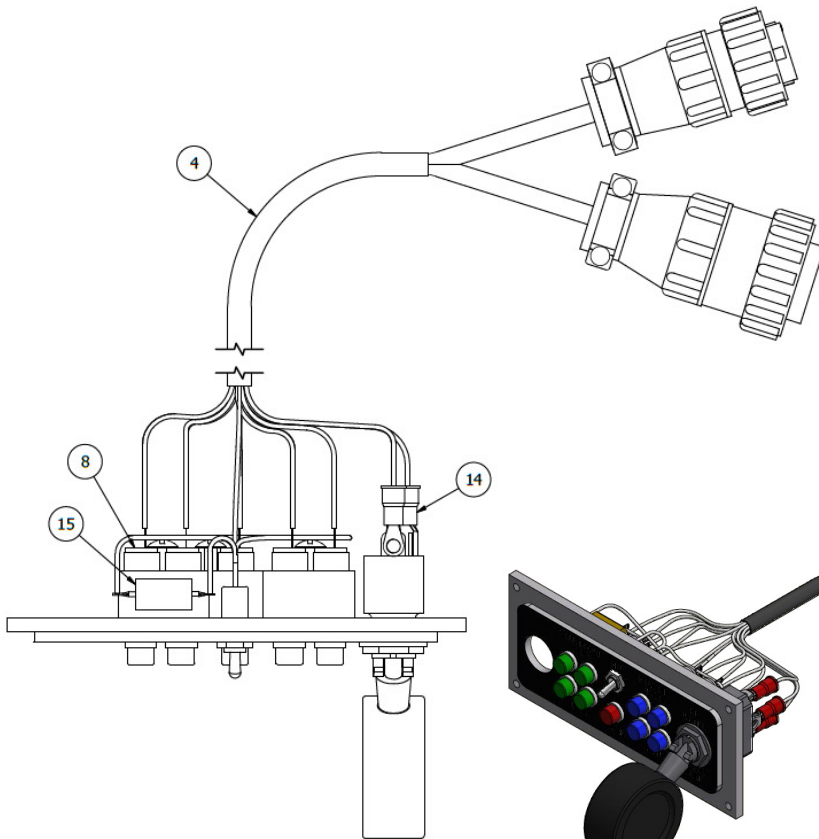
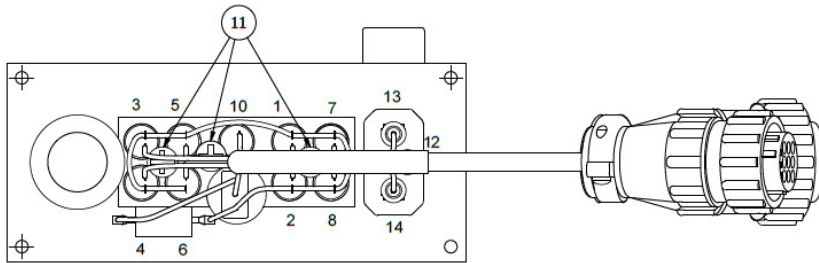

ITEM	QTY	PART NO.	PART DESCRIPTION
-	1	21A11000-010	ASSEMBLY, INDICATOR, GEAR CONTROL, SQUARE, 12V
-	1	21A11000-018	GEAR SELECTOR ASSY. RECTANGLE (24V)
1	1	10B3-6277	PLACARD, GEAR CONTROL SQUARE
2	1	21A11179-002	BLOCK GEAR CONTROL SQUARE
3	1	21A11259-003	GEAR SWITCH KNOB
4	1	4A11000-008	WIRING HARNESS ASSY. SELECTOR
	3 IN	HS105-1/2-0	HEAT SHRINK TUBING
5	1	507-3914-1431-600F	LAMP LIGHT, RED 14V
	1	507-3918-1431-600F	INDICATOR LAMP, 28V, RED
6	4	507-3914-1432-600F	LAMP LIGHT, GREEN 14V
	4	507-3918-1432-600F	INDICATOR LAMP, 28V, GREEN
7	4	507-3914-1434-600F	LAMP LIGHT, BLUE, 14V
	4	507-3918-1434-600F	INDICATOR LAMP, 28V, BLUE
8	9	515-0012	SOCKET
9	1	8857K44	SWITCH
10	1	A101SYCB	TOGGLE SWITCH
11	3	AN526-632R8	SCREW, TRUSS HEAD MACHINE, 6-32 THREAD, 1/2" LENGTH
12	12"	HS105-3/32-0	HEAT SHRINK, TUBING - BLACK
13	3	PLT1M-M	CABLE TIE, NYLON, WHITE, 4" (SMALL)
14	3	R-3	TERMINAL, RING #6 STUD, 16-22 AWG, RED
15	1	RH-5-35	RESISTOR, 14V, DALE RH5 5W
	1	RH-5-180	RESISTOR, 28V, DALE RH5 5W
16	6 IN	22759-16-20-9	WIRE, 20AWG, WHITE (NOT SHOWN)
17	16 IN	HIXR-3/16	SHRINK WRAP, 3/16, WHITE (NOT SHOWN)

GEAR CONTROL (G1000 ONLY)

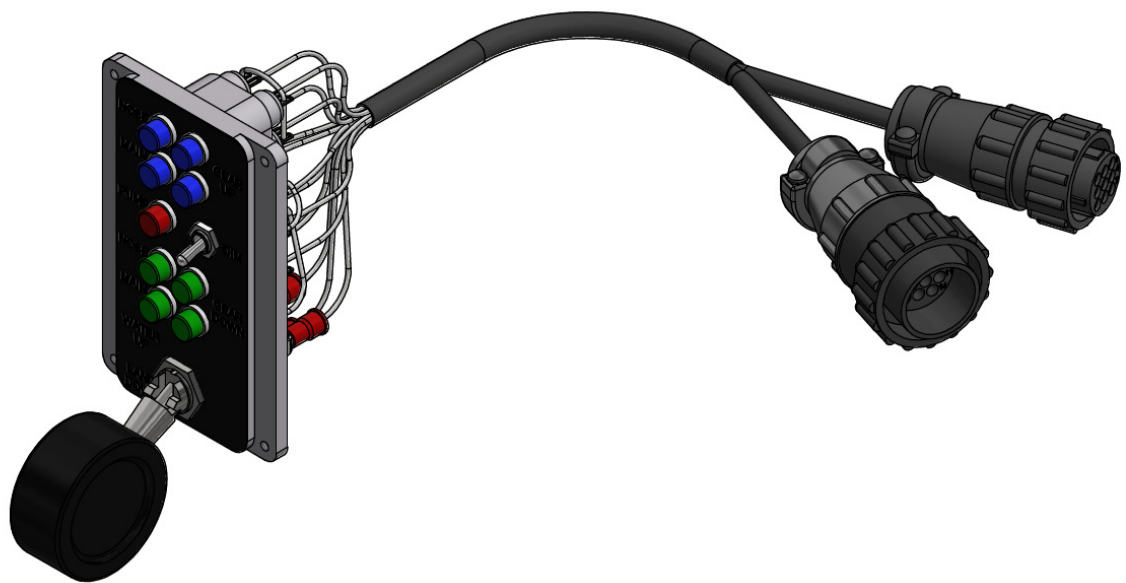
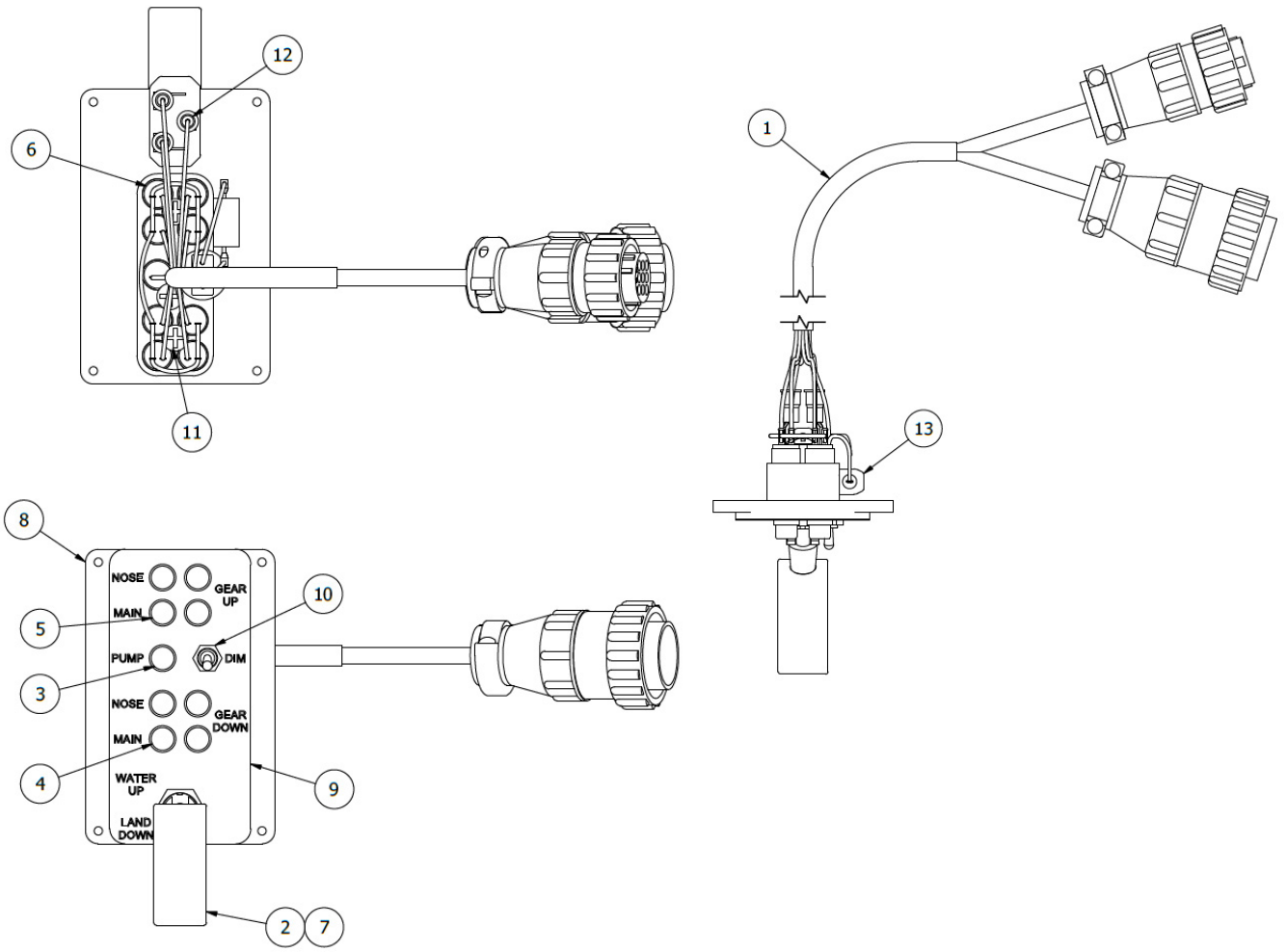

ITEM	QTY	PART NO.	PART DESCRIPTION
-	1	1001431	ASSEMBLY, INDICATOR, GEAR CONTROL, G1000
1	1	4A11000-008	ASSEMBLY, WIRE HARNESS
2	1	21A11259-003	GEAR SWITCH KNOB
3	1	507-3918-1431-600F	INDICATOR LAMP, 28V, RED
4	4	507-3918-1432-600F	INDICATOR LAMP, 28V, GRN
5	4	507-3918-1434-600F	INDICATOR LAMP, 28V, BLU
6	9	515-0012	SOCKET, GEAR SELECTOR LIGHTS
7	1	8857K44	SWITCH, GEAR SELECTOR, 2100/7000
8	1	1001172	BLOCK, GEAR CONTROL, GLASS PANEL
9	1	1001173	PLACARD, GEAR CONTROL, GLASS PANEL
10	1	A101SYCB	TOGGLE SWITCH, SPDT, ON ON
11	3	AN526-632R6	SCREW, MACHINE, TRUSS HEAD
12	3	MS25036-102	RING TERMINAL, #6 STUD, 16-22 AWG, RED
13	1	RH005180R0FE02	RESISTOR, 28V