



WIPLINE FLOATS • SKIS • MODIFICATIONS • AIRCRAFT SALES
AVIONICS • INTERIOR • MAINTENANCE • PAINT REFINISHING

SERVICE LETTER 180

8000A MAIN GEAR ASSEMBLY CUSTOM WASHER INSTALLATION

Aircraft Makes/Model(s):	Float Model(s):	Compliance: Mandatory	By: MAB
208, DHC-3	8000A	Part Number: 1009538	Approved: SDW
		Date: 6/30/2020	Revision: E

LOG OF REVISIONS

Revision	Description	Date
A	Initial release	9/5/2017
B	Added trimming washer instruction, removed 208B and added DHC-3 to applicability	1/19/2018
C	Added service kit part number to Bill of Materials	4/15/2019
D	Updated bolt part numbers	7/11/2019
E	Updated warranty information	6/30/2020

FAA approval has been obtained for technical data in this publication that affects STC or TSO design compliance

EFFECTIVITY:

This service letter applies to: Cessna 208 and DeHavilland DHC-3 with Wipline 8000 amphibious floats installed per STC SA1311GL.

COMPLIANCE:

Compliance with service letter 180 is mandatory and must be completed within 12 months of the service letter initial release.

BACKGROUND:

Cracks have been found on the main gear drag brace tube and main gear axle assembly due to stress when torquing the nuts. A custom washer has been made to replace the current washers in the main gear drag brace tube.

COMPLIANCE METHOD:

Inspect main gear assembly for cracks per Work Instruction. Replace the (16) internal washers on each main gear assembly with new custom washers provided.

APPROXIMATE SHOP HOURS:

Replacing the main gear drag brace tube and washers will take approximately 4 hours per float after aircraft has been jacked.

WARRANTY INFORMATION:

Parts and labor costs for this service letter are at the owner's expense.

TECHNICAL DATA:

Copies of this service letter, associated service kit, float service manual, and float parts manual are available at www.wipaire.com.

1700 Henry Ave - Fleming Field (KSGS), South St. Paul, MN 55075

Phone: 651.451.1205 | Fax: 651.457.7858

www.wipaire.com



ITEMS PROVIDED IN SERVICE KIT 1009538-01 (PER FLOAT SET)

ITEM	QTY	PART NUMBER	DESCRIPTION
1	16	1009495	Custom Drag Brace Washer
2	16	1009496	Custom Drag Brace Washer
3	6	MS24665-285	Cotter Pin
4	20	AN6-12A	Bolt
5	4	AN6-13A	Bolt
6	8	AN6-14A	Bolt
7	32	MS21044N6	Nut
8	32	NAS1149D0663J	Washer

WORK INSTRUCTION

1. Safely jack aircraft so all wheels are off the ground when the main gear is extended
2. Pull gear select, pump 1, and pump 2 circuit breakers.
3. Pull aircraft parking brake lever.

NOTE: Do not push on brake pedal while pulling the aircraft parking brake lever.

4. Disconnect brake lines at bulkhead 10 and cap each end of hydraulic bulkhead tee fitting and plug each hydraulic brake line.
5. Remove main wheel and tire assemblies.
6. Remove cotter pin, nut, and washer from each AN bolt at each trunnion attach point.
7. Remove cotter pin, nut, washers, and NAS bolt at the oleo attach point.

WARNING!

**The main gear assembly will detach from the float after completing step 8.
Support the assembly appropriately prior to removing the attaching hardware.**

8. Remove each AN bolt at the trunnion attach point and remove main gear drag link assembly from float.

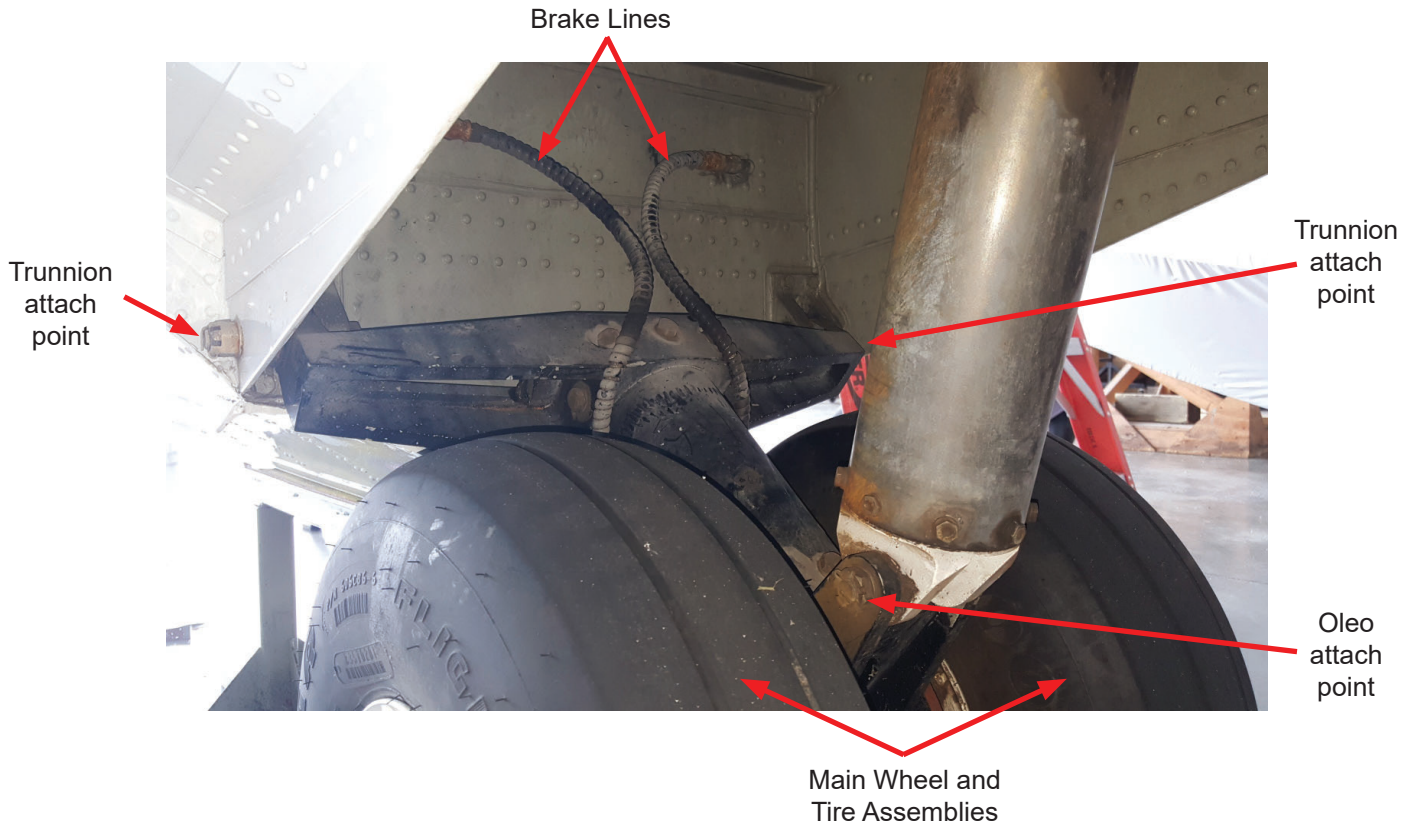

9. Remove the top (8) AN bolts and associated (16) washers and (8) nuts.



10. Remove the lower (8) AN bolts and associated (16) washers and (8) nuts.

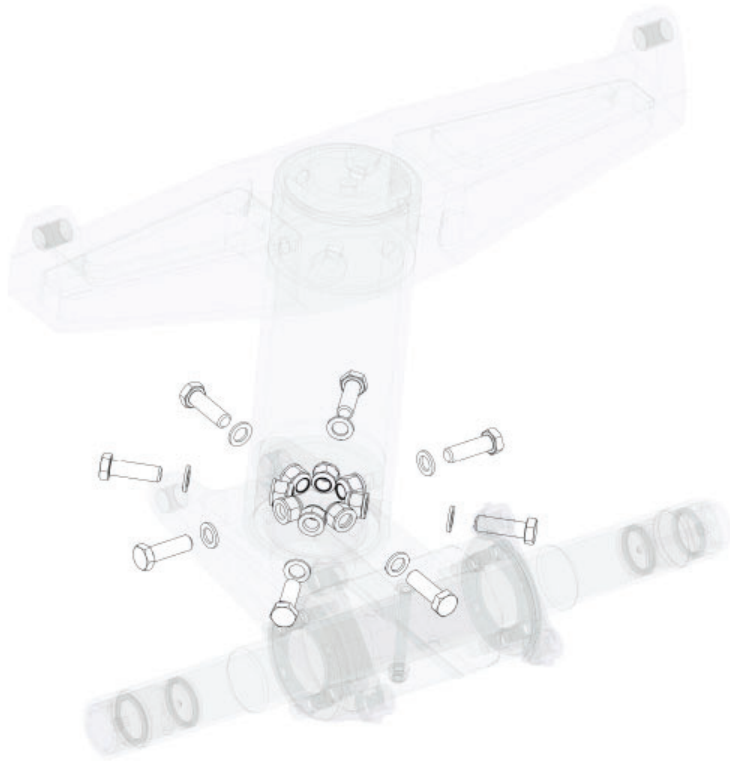

11. Separate the 8A04103-001 drag brace assembly, 8A04000-021 main gear axle assembly, and 8A04296-002 main gear drag brace tube

12. Thoroughly inspect from the interior and exterior of following areas:

- 8A04296-002 main gear drag brace tube for cracks where the (16) bolts were removed from.
- 8A04000-021 main gear axle assembly where the (8) bolts were removed from.

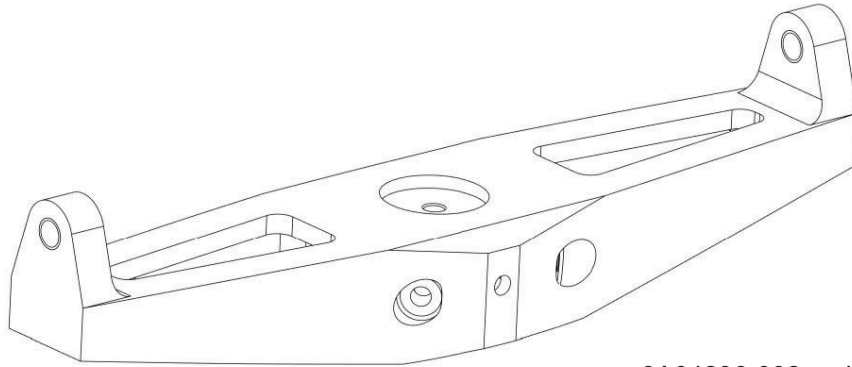

8A04296-002 main gear drag brace tube for cracks where the top (8) bolts were removed from.

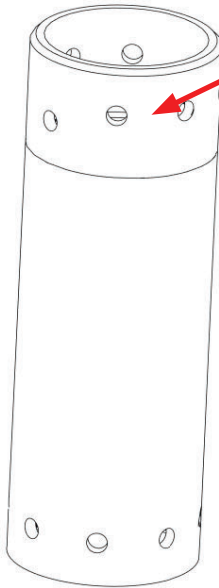

8A04000-021 main gear axle assembly where the (8) bolts were removed from.

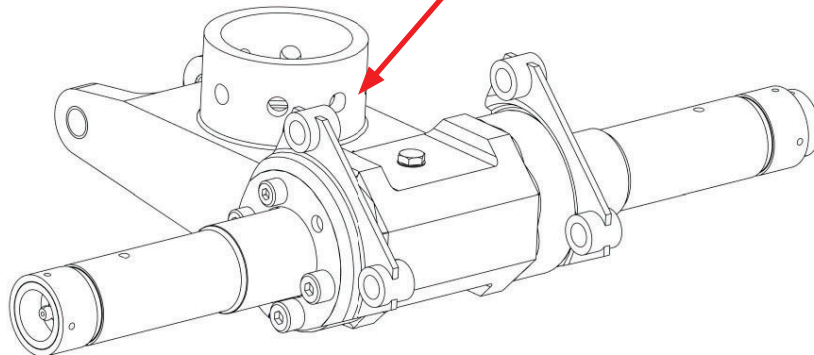

13. Replace any components that have cracks.
14. Remove existing (16) internal and external washers.
15. Reassemble 8A04000-019 main gear assembly without wheels as shown using new hardware provided:

NOTE: Apply corrosion inhibitor during reassembly of mating components

⚠ NOTE: Washer may need to be trimmed as shown below:

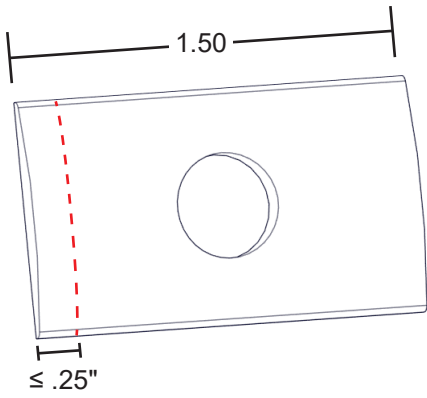

Depending on aircraft, trim up to .25 inches from edge of washer if interference exists

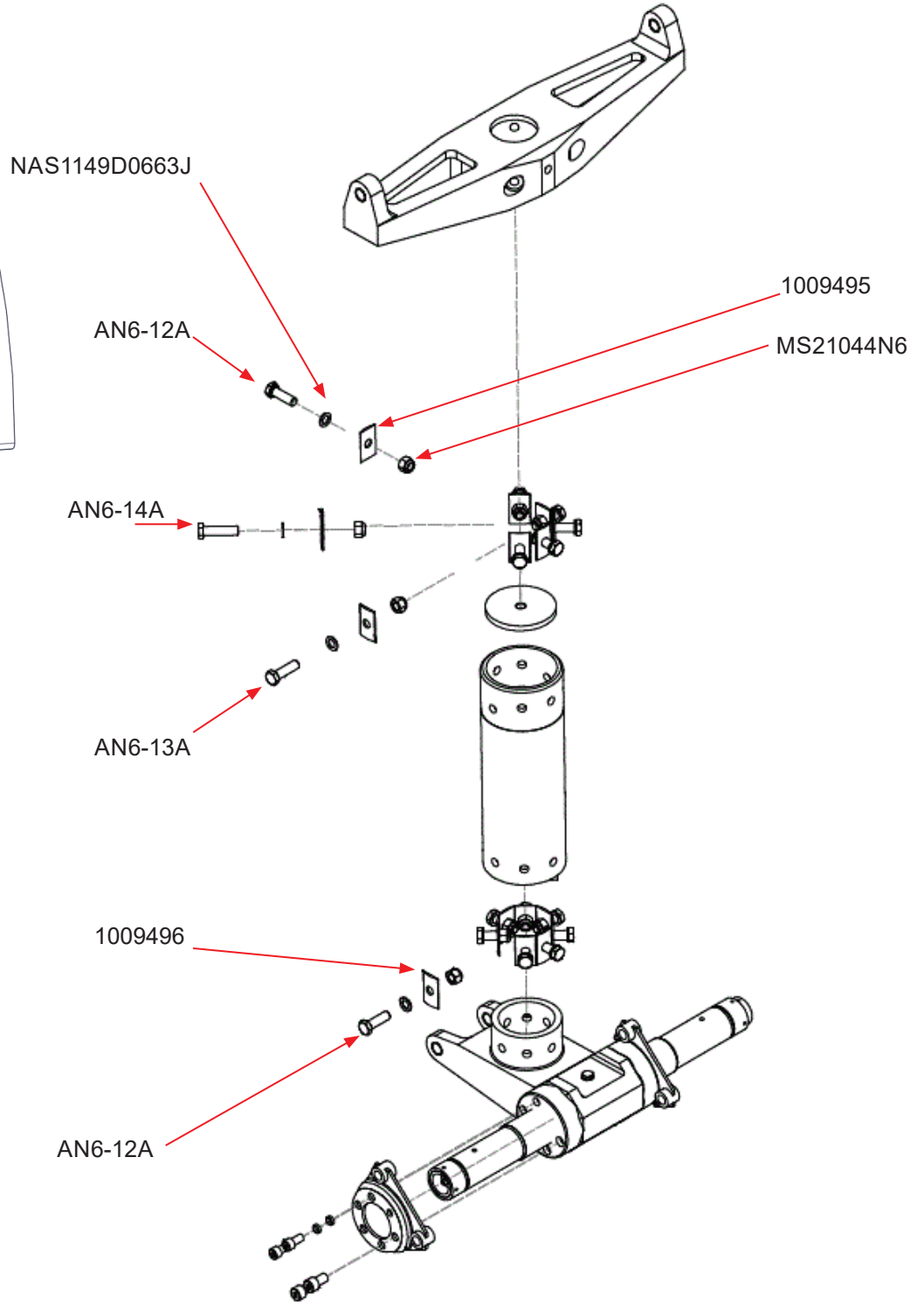

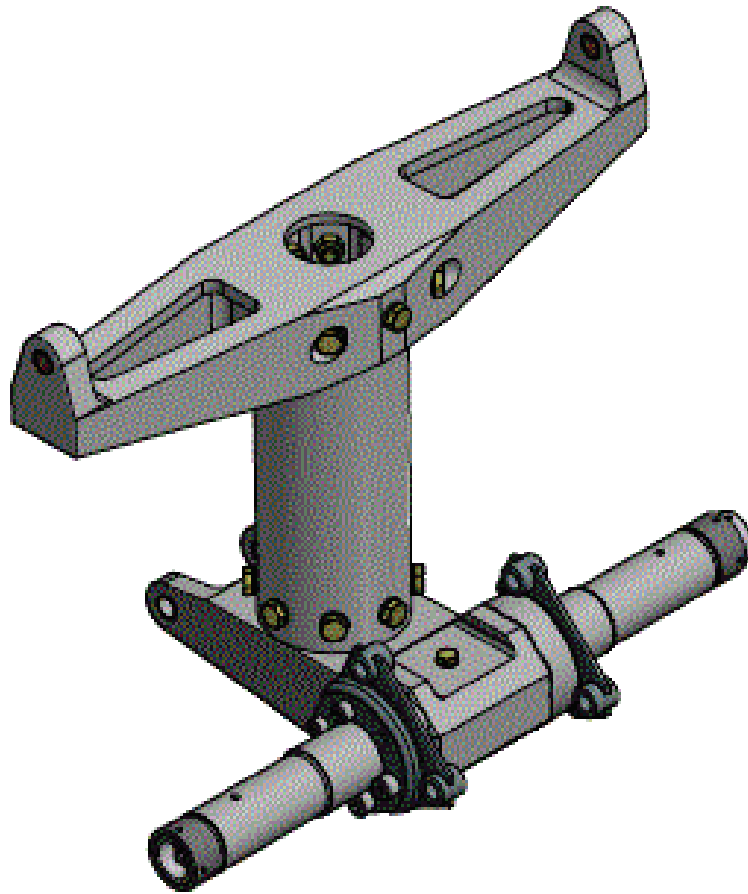

ASSEMBLED MAIN GEAR VIEW

16. Apply a light coating of grease or equivalent to each trunnion attach point.
17. Install main gear assembly without wheels at each trunnion attach point using (2) AN bolts.
18. Apply a light coating of grease or equivalent to the bolt and pivot points at the oleo attach point.
19. Connect the oleo assembly to the main gear assembly using NAS bolt, washers, nut, and new cotter pin.
20. Install nuts, washers, and new cotter pins on each AN bolt at each trunnion attach point.
21. Apply corrosion inhibitor on nuts and bolts where needed.
22. Reinstall main wheel and tire assemblies.
23. Reconnect brake lines at bulkhead 10.
24. Release aircraft parking brake lever.
25. Bleed the brake system.
26. Push in gear select, pump 1, and pump 2 circuit breakers.
27. Fully cycle the hydraulic gear system up and down to ensure correct operation.
28. Remove aircraft jacks.
29. Upon completion of inspection, enter information in Aircraft Logbook for completion of this Wipaire service letter.