



WIPLINE FLOATS • SKIS • MODIFICATIONS • AIRCRAFT SALES
AVIONICS • INTERIOR • MAINTENANCE • PAINT REFINISHING

SERVICE LETTER 196

10000 BILGE PUMP REPLACEMENT

Aircraft Makes/Model(s):	Float Model(s):	Compliance: Optional	By: MAB
AT-802 AT-802A	10000	Part Number: 1011030	Approved: SDW
		Date: 10/22/2019	Revision: B

LOG OF REVISIONS

Revision	Description	Date
A	Initial release	4/15/2019
B	Updated float serial number effectivity.	10/22/2019

FAA approval has been obtained for technical data in this publication that affects STC or TSO design compliance.



EFFECTIVITY:

This service letter applies to Air Tractor models AT-802 and AT-802A with Wipline 10000A Fireboss Amphibious Float serial numbers 10203A/10204A and prior installed per STC SA01795CH.

COMPLIANCE:

Optional compliance

BACKGROUND:

The bilge pump that was previously used in Wipline 10000A Fireboss Amphibious Floats is no longer available. A replacement pump is now offered, but this pump uses a different mounting hole pattern. This service letter provides installation instructions to replace the bilge pump.

COMPLIANCE METHOD:

Install provided parts as shown in the Work Instruction section of this service letter.

APPROXIMATE SHOP HOURS:

Installing the bilge pump will take approximately 4 labor hours per float.

WARRANTY INFORMATION:

This service letter does not include warranty for labor and parts.

TECHNICAL DATA:

Copies of this service letter, associated service kit (if applicable), float service manual, and float parts manual are available at www.wipaire.com.

1700 Henry Ave - Fleming Field (KSGS), South St. Paul, MN 55075

Phone: 651.451.1205 | Fax: 651.457.7858

www.wipaire.com

ITEMS PROVIDED IN SERVICE KIT 1011030-01 (1 FLOAT)

ITEM	QTY	PART NUMBER	DESCRIPTION
1	1	1007499	ASSEMBLY, BILGE PUMP, RM500B-24
2	2	1007498	MOUNT, BILGE PUMP

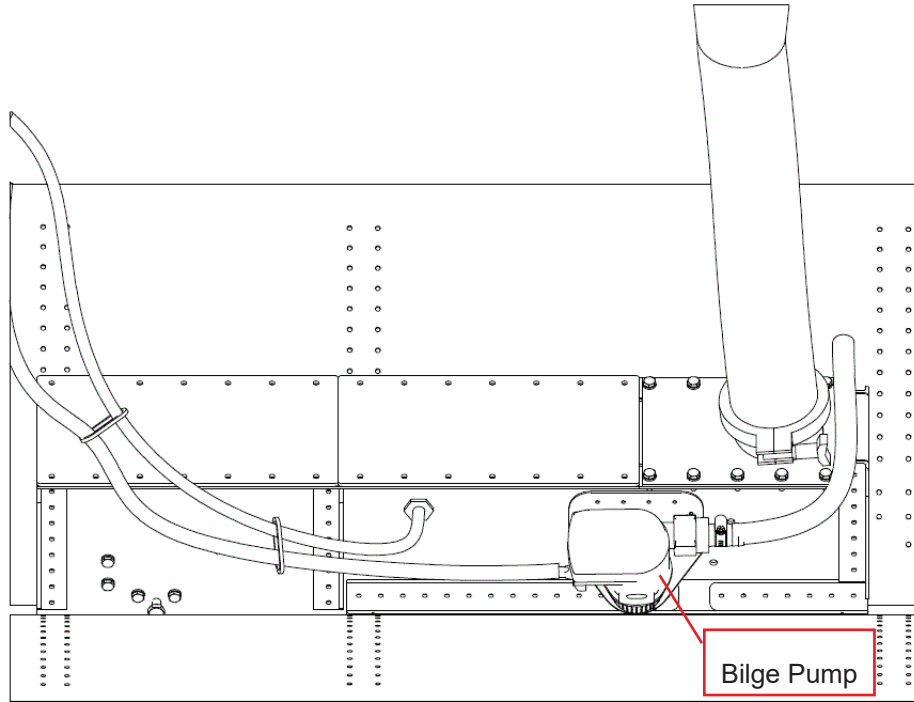

Scoop Tunnel

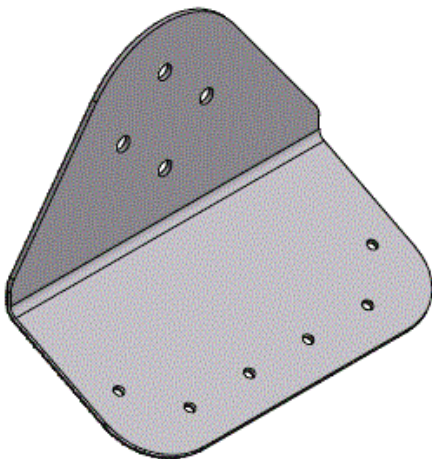

Bilge Pump Mount

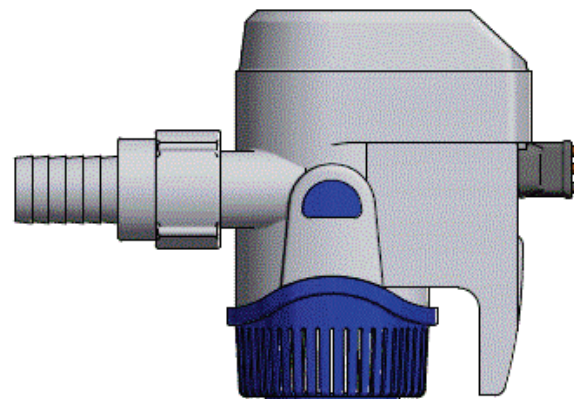

Bilge Pump, 24V, 500 GPH

WORK INSTRUCTION

1. Access scoop tunnel through float foam tank/baggage compartment.
2. Remove old bilge pump assembly.
3. If installing new bilge pump mounting bracket, remove all hardware holding scoop tunnel cover in place. If using existing bracket, simply drill new holes into bracket to match new bilge pump mount and install pump.
4. Remove old pump bracket.
5. Install new mounting bracket with appropriate rivets.
6. Mount bilge pump to new bracket.



Bilge Pump On Scoop Tunnel

AIRCRAFT CLOSING AND RETURN TO SERVICE

1. Upon completion of inspection, enter information in Aircraft Logbook for completion of this Wipaire service letter.