



SERVICE LETTER NUMBER 157			
10000 BULKHEADS 8-12, LOWER FLANGE REINFORCEMENT			
BY: MAB	AIRCRAFT	FLOAT MODEL(S):	NOTES: OPTIONAL
APP: SDW	MAKE/MODEL(S):	10000	COMPLIANCE
DATE: 5/21/2019	AIR TRACTOR		S/L P/N 1008067
REV: B	AT-802, AT-802A		

FAA APPROVAL HAS BEEN OBTAINED FOR TECHNICAL DATA IN THIS PUBLICATION THAT AFFECTS STC OR TSO DESIGN COMPLIANCE

EFFECTIVITY:

This service letter applies to Air Tractor AT-802 and AT-802A when equipped with Wipline model 10000 floats (STC SA01795CH).

COMPLIANCE:

Compliance with this service letter is optional and is recommended for aircraft operating regularly in rough water conditions. It is acceptable to apply the service letter proactively to floats that do not exhibit cracks.

BACKGROUND:

Aircraft equipped with Wipline model 10000 amphibian floats that regularly operate in rough water, may experience cracking of the forward and aft lower bulkhead flanges located in the baggage area of the float as indicated in Figure 1. This service letter and associated kit reinforce the lower bulkhead flanges to reduce probability of cracking as a result of operations in rough water.

COMPLIANCE METHOD:

Install the parts included in Kit 1008067 in accordance with the instructions in the Inspection and Repair Procedure section of this service letter and applicable Float Service Manual P/N 1002545 (AT-802A) or P/N 1003546 (AT-802).

APPROXIMATE SHOP HOURS:

This service letter will take approximately 40 labor hours to complete. Additional time may be required if foam tanks are installed.

WARRANTY INFORMATION:

This service letter does not include any warranty, labor, or parts.

TECHNICAL DATA:

Copies of this service letter, float service manual, modification drawings, and float parts manual are available at www.wipaire.com.

For basic float model maintenance information, see applicable Fire Boss Service Manual P/N 1002545 (AT-802A) or P/N 1003546 (AT-802) at www.wipaire.com.

For basic float model parts information, see applicable Fire Boss Parts Manual P/N 1002179 at www.wipaire.com.

PARTS LIST FOR 10000 FLOAT LOWER FLANGE REINFORCEMENT: 1008067

ITEM	QTY	PART NUMBER	DESCRIPTION
1	4	1008061	DOUBLER, LOWER BULKHEAD REINFORCEMENT
2	4	1008062	DOUBLER, LOWER BULKHEAD REINFORCEMENT
3	2	1008063	DOUBLER, LOWER BULKHEAD REINFORCEMENT
4	2	1008064	DOUBLER, LOWER BULKHEAD REINFORCEMENT
5	1	1008065	DOUBLER, LOWER BULKHEAD REINFORCEMENT
6	1	1008066	DOUBLER, LOWER BULKHEAD REINFORCEMENT
7	1	1008068	DOUBLER, LOWER BULKHEAD REINFORCEMENT
8	1	1008069	DOUBLER, LOWER BULKHEAD REINFORCEMENT
9	1	1011033	DOUBLER, LOWER BULKHEAD REINFORCEMENT
10	1	1011034	DOUBLER, LOWER BULKHEAD REINFORCEMENT
11	1	1011035	DOUBLER, LOWER BULKHEAD REINFORCEMENT
12	1	1011036	DOUBLER, LOWER BULKHEAD REINFORCEMENT

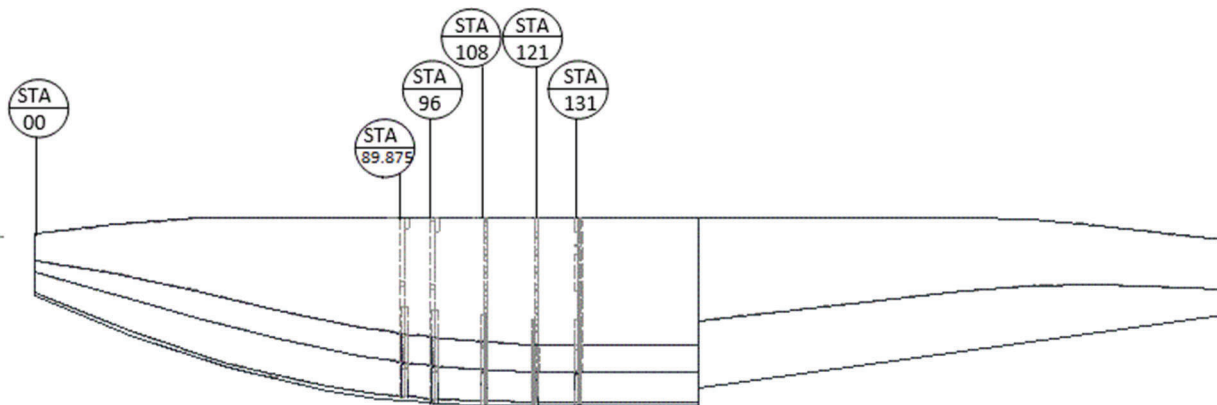

FIGURE 1: AFFECTED BULKHEAD FLOAT STATION LOCATIONS

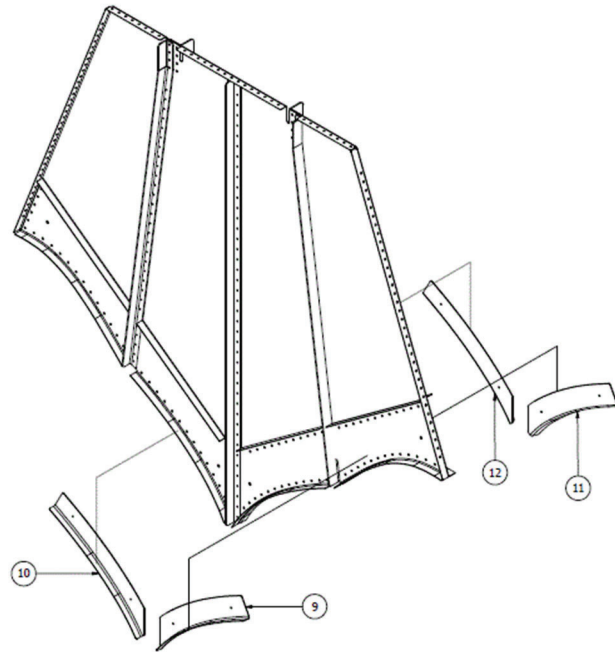

FIGURE 2: BULKHEAD 1007923 AT FLOAT STA 89.875

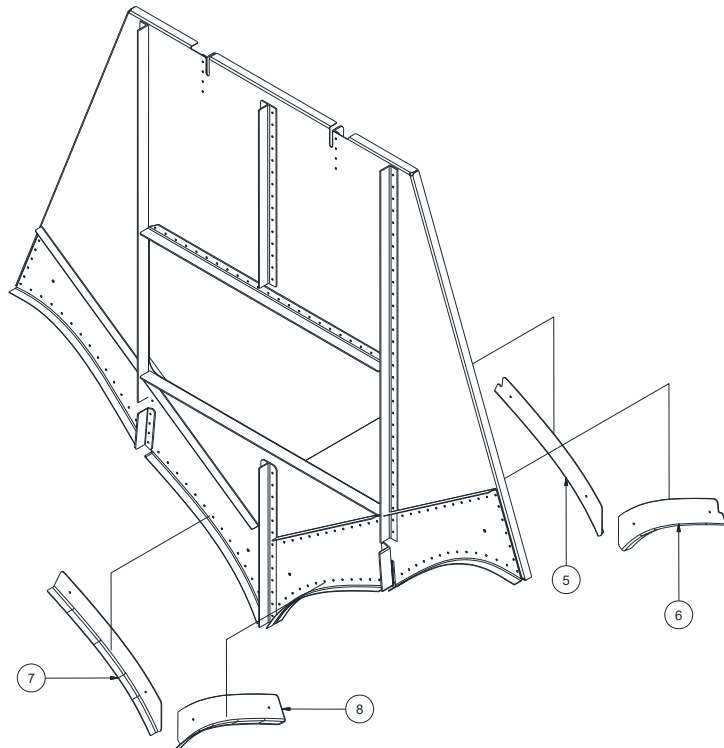

FIGURE 3: BULKHEAD 1007924 AT FLOAT STA 96

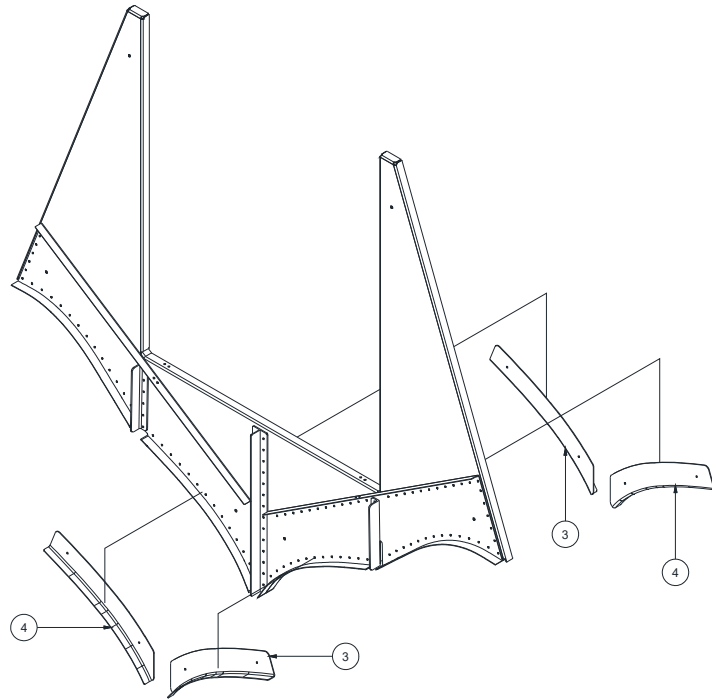

FIGURE 4: BULKHEAD 1007925 AT FLOAT STA 108

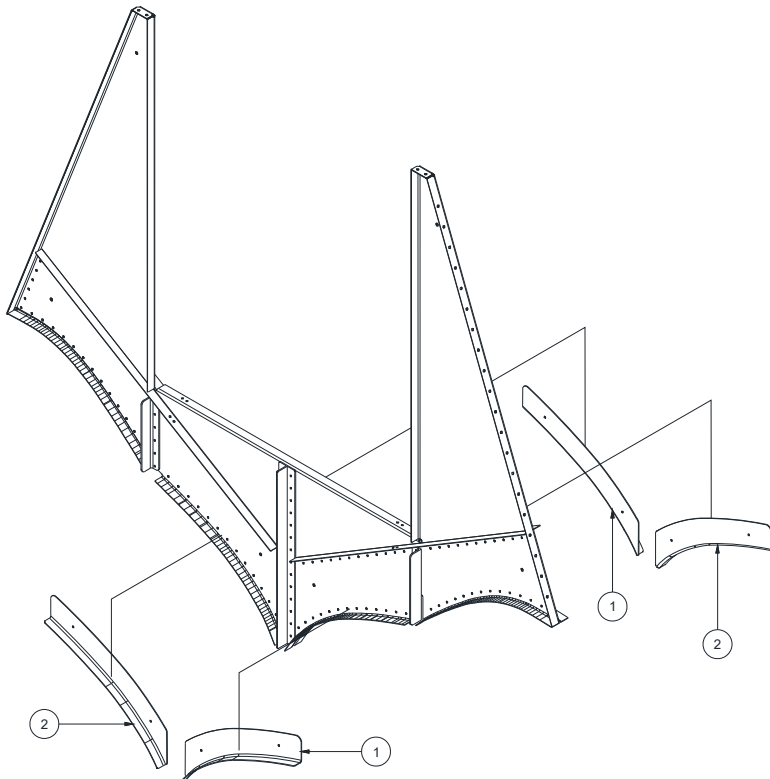

FIGURE 5: BULKHEAD 1007926 AT FLOAT STA 121

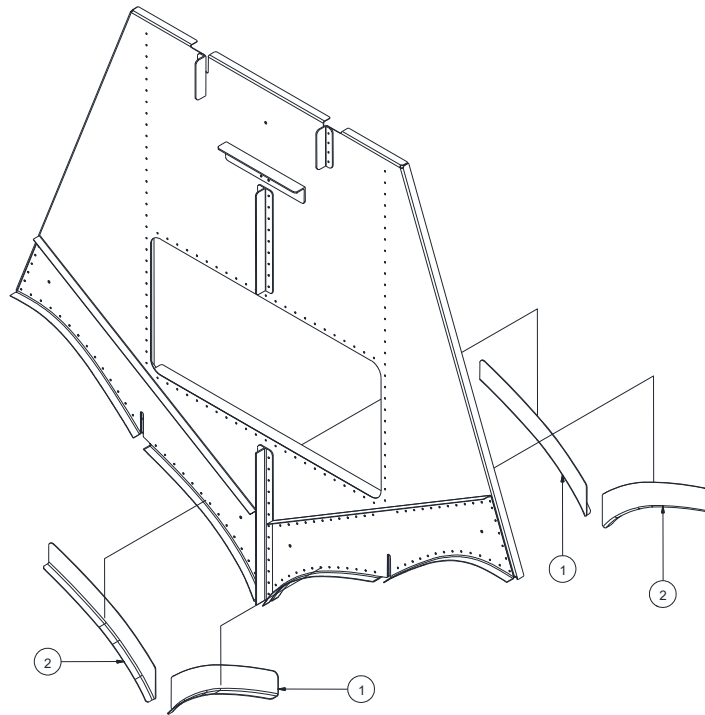

FIGURE 6: BULKHEAD 1007927 AT FLOAT STA 131

INSPECTION & REPAIR PROCEDURE:

- 1) Remove the top deck covers and open baggage hatches to gain access to the affected bulkheads shown in Figure 1. Remove baggage hatch floors to gain access to lower bulkhead flanges.
- 2) If cracks are found in flanges, stop drill as needed.
- 3) After drilling interfering rivets out of existing bulkhead, position the doublers best fit to contour and match drill at each forward and aft lower bulkhead flange.

- 1) Match drill these rows to existing rivet locations in lower flange and bulkhead face.
- 2) Add this upper row at 0.5 inch edge distance using the forward doubler, and then match drill into the aft doubler. Match lower row spacing.

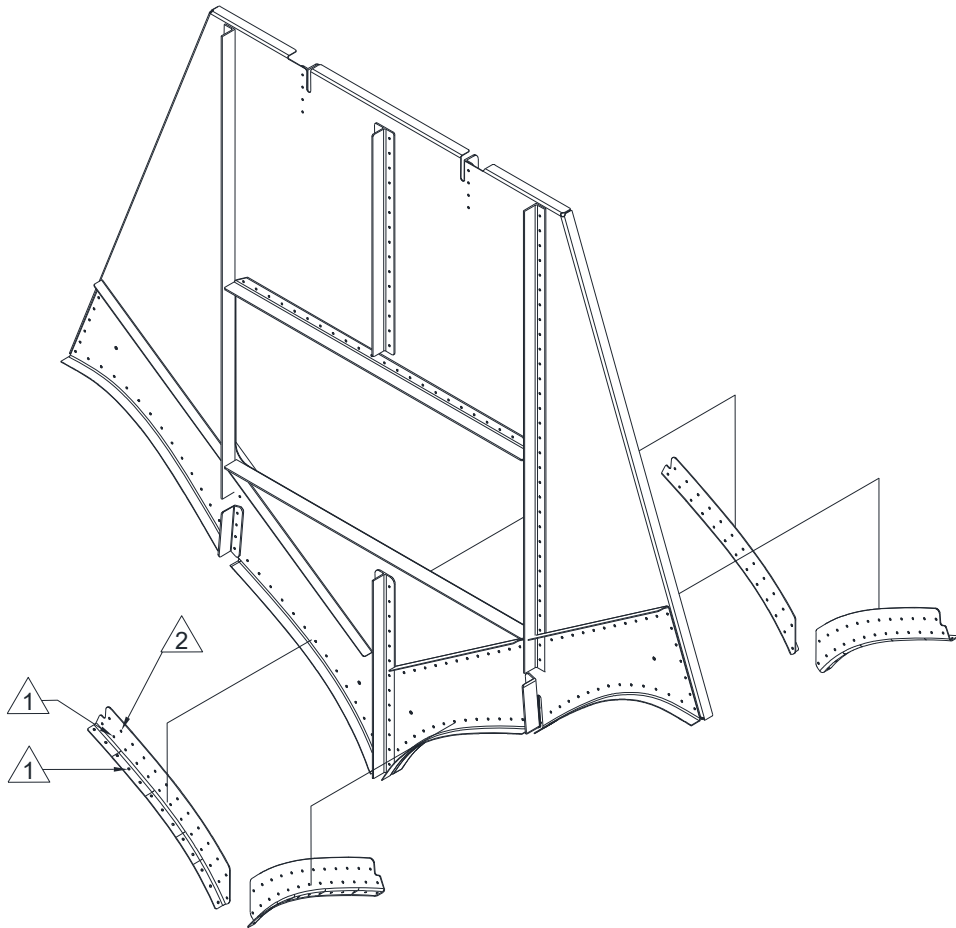

FIGURE 7: RIVET DIAGRAM FOR BULKHEAD DOUBLERS

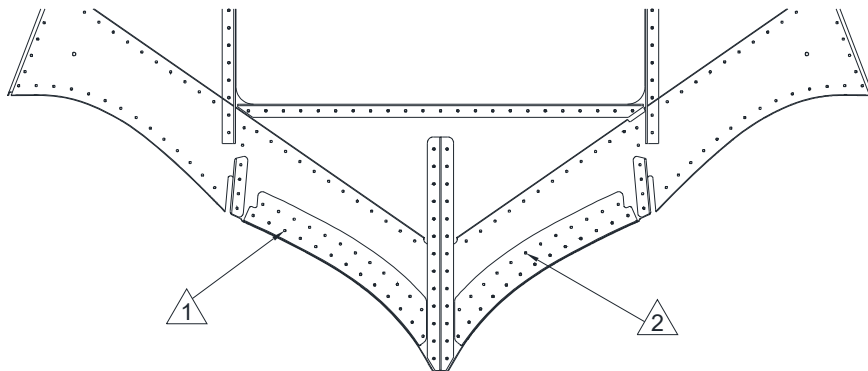

FIGURE 8: FRONT VIEW – BULKHEAD DOUBLERS AND RIVET LOCATIONS

- 4) Deburr all drilled rivet holes in bulkheads and doublers.
- 5) One doubler at a time; apply PR1422 sealant completely to mating faces of doubler, bulkhead, and bottom skin, then rivet appropriate doublers as called out in the Parts List and Figures 2-6 to the forward and aft lower bulkhead flanges and bottom skin using MS20470AD4 rivets, grip as required. Perform this operation at bow bulkheads indicated in Figure 1. Drive rivets while sealant is wet.
- 6) Wipe away excess wet sealant after riveting.
- 7) Replace baggage hatch floors and reinstall top deck covers with new seals.
- 8) Water check floats

NOTES:

- 1) Upon completion, enter information in float logbook for completion of Wipaire Service Letter 157.
- 2) Once service letter is accomplished, please visit www.wipaire.com and update your aircraft service letter/kit record using the link found on the Customer Support dropdown menu under "Update Service Letter & Kit Compliance Status."
- 3) Wipaire considers the weight and balance effect of this modification to be negligible; however, consult your local Civil Aviation Regulations with respect to logbook weight and balance entry requirements.