



WIPLINE FLOATS • SKIS • MODIFICATIONS • AIRCRAFT SALES  
AVIONICS • INTERIOR • MAINTENANCE • PAINT REFINISHING



**PARTS MANUAL  
FOR  
WIPLINE MODEL 3450 FLOATS  
ON  
CESSNA 206**

**Revision N**

1700 Henry Ave. - Fleming Field (KSGS), South St. Paul, MN 55075  
Ph: 651.451.1205 Fax: 651.457.7858  
[www.wipaire.com](http://www.wipaire.com)

THIS PAGE INTENTIONALLY LEFT BLANK

### LOG OF REVISIONS

Revision	Pages Affected	Description	Date
A - L	All	For previous revision changes, reference Parts Manual for 3450 Floats on Cessna 206 Revision L part number 1002174.	5/26/2021
M	All	Added section for Service Letter 241 and 242. Added Hydraulic Pump (FWD Nose Wheel Well) Installation image and parts. Added Hydraulic Pump (FWD Nose Wheel Well) Assembly image and parts. Added Electronic Side Plate (FWD Nose Wheel Well) Assembly image and parts. Added Hydraulic Pump Firewall (Soloy Only) Installation image and parts. Added Hydraulic Pump Firewall (Soloy Only) Assembly image and parts. Added Assembly Support Plate Firewall (Soloy Only) image and parts. Added Gear Control (Rectangle) (G1000 Only) image and parts.	1/5/2022
N	79, 83, 87	Changed 010-026 Seal to 471570 Seal, Timken. Updated part 30A05558-001 and added 1005973 in Main Gear Installation and Main Gear Hydraulic Installation sections. Added note for 1002573.	4/22/2022

View most current version of parts manual at [www.wipaire.com](http://www.wipaire.com).

THIS PAGE INTENTIONALLY LEFT BLANK



## TABLE OF CONTENTS

FLOAT PART SALES DEPARTMENT OPERATIONS .....	6
INTRODUCTION .....	7
SECTION 1 HULL BULKHEAD ASSEMBLIES .....	9
SECTION 2 WHEEL WELL ASSEMBLY .....	29
SECTION 3 SKINS, STIFFENERS, & PADDLE .....	35
SECTION 4 TOP DECK ASSEMBLY .....	45
SECTION 5 EXTRUSIONS .....	53
SECTION 6 PUMPER TUBE INSTALLATION .....	59
SECTION 7 WATER RUDDER, STEERING, AND RETRACT CABLES .....	61
SECTION 8 LANDING GEAR .....	73
SECTION 9 STRUTS, WIRES, STEPS, AND SPREADER BARS .....	101
SECTION 10 HYDRAULIC SYSTEM .....	107
SECTION 11 ELECTRICAL .....	141
SECTION 12 VENTRAL FIN .....	153

## FLOAT PART SALES DEPARTMENT OPERATIONS

### Parts Sales:

Wipaire, Inc.

1700 Henry Avenue – Fleming Field

South St. Paul, MN 55075

Telephone: (651) 306-0459

Fax: (651)-306-0666

Website: [www.wipaire.com](http://www.wipaire.com)

Email: [customerservice@wipaire.com](mailto:customerservice@wipaire.com)

**Note:** Any information not found in this manual for strut package parts and other installation items refer to the installation drawing package provided with the STC at the time of float installation. Additional drawing copies are available for purchase through the Wipaire Customer Service Department.

### Parts Ordering

Purchase orders should include:

1. Purchase order number
2. Name of person placing order
3. Invoicing information:
  - a. Customer name - company or individual
  - b. Address
  - c. Phone and fax number
4. Shipping information:
  - a. Address (if different from invoice address)
  - b. Method of shipment/preferred carrier
5. Aircraft model, float model, and serial numbers
6. Wipaire part number; name; type, e.g. left or right; quantity
7. Payment method: VISA, MasterCard, C.O.D. (Collect on Delivery) (U.S. customers only), pre-payment by check or wire transfer, open account (see Credit Policy)

## INTRODUCTION

All references in this manual to LEFT and RIGHT are from the perspective of the pilot's seat with the floats fully installed and ready for floatplane operation.

The following is a list of abbreviations that may appear in the description nomenclature fields of this manual:

AB	Afterbody	Inbd.	Inboard
Amphib.	Amphibious	Lg.	Large
AR	As Required	Lt.	Left
Assy.	Assembly	Lwr.	Lower
Brkt.	Bracket	Opt.	Optional
Btm.	Bottom	Otbd.	Outboard
Bulk.	Bulkhead	Reinf.	Reinforcement
Ctr.	Center	Rr.	Rear
Cyl.	Cylinder	Rt.	Right
Ft.	Front	Sm.	Small
Ftg.	Fitting	SN	Serial Number
Fus.	Fuselage	Spr.	Spreader
Fwd	Forward	Upr.	Upper
Horiz.	Horizontal	Vert.	Vertical
Hyd.	Hydraulic	W.W.	Wheel Well

## USING THIS PARTS MANUAL

### COVERAGE

Parts information is provided in this manual for the hulls and all "deck down" parts. For information on strut package parts and other aircraft installation items, refer to the installation drawing package provided with the STC at the time of float installation. Additional drawing copies are available for purchase through Wipaire Customer Service Department.

Name of main part in the section. Example: This part is showing the components made up in Bulkhead #1.

### BULKHEAD #1

Main part image. If the image has numbers associated with it, then those numbers are item numbers shown in the table below.

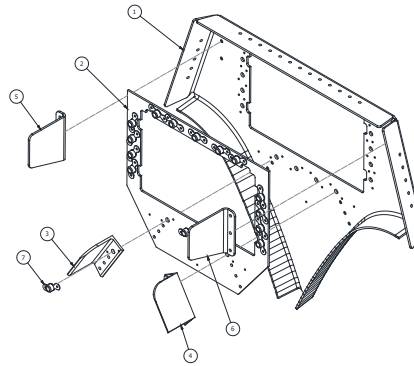

Items with a (-) instead of a number represent the main part as an assembly. Other parts represent the parts included in the assembly.

ITEM	QTY	PART NO.	PART DESCRIPTION
-	1	1008815	ASSEMBLY BULKHEAD #1, 10000
1	1	1008797	PANEL, BULKHEAD #1
2	1	13A01156-085	DOUBLER #1 BULKHEAD
3	1	13A01357-049	CLEAT, SISTER KEEL ATTACH #1 BULKHEAD
4	1	13A01357-050	CLEAT, SISTER KEEL ATTACH #1 BULKHEAD
5	1	6A01156-054	ANGLE – TOP RAIL
6	1	6A01156-055	ANGLE – TOP RAIL
7	17	MS21047L4	NUT PLATE, SELF LOCKING

To order an individual part, order the part number associated with item number.

# SECTION 1 HULL BULKHEAD ASSEMBLIES

## CONTENTS

HULL ASSEMBLY.....	10
BULKHEAD #1.....	13
BULKHEAD #3.....	14
BULKHEAD #4.....	15
BULKHEAD #5.....	16
BULKHEAD #6.....	17
BULKHEAD #7.....	18
BULKHEAD #8.....	19
BULKHEAD #8.....	20
BULKHEAD #9.....	21
BULKHEAD #10.....	22
BULKHEAD #11.....	23
BULKHEAD #12.....	24
BULKHEAD #13.....	25
BULKHEAD #15.....	26
BULKHEAD #16.....	27

# HULL ASSEMBLY

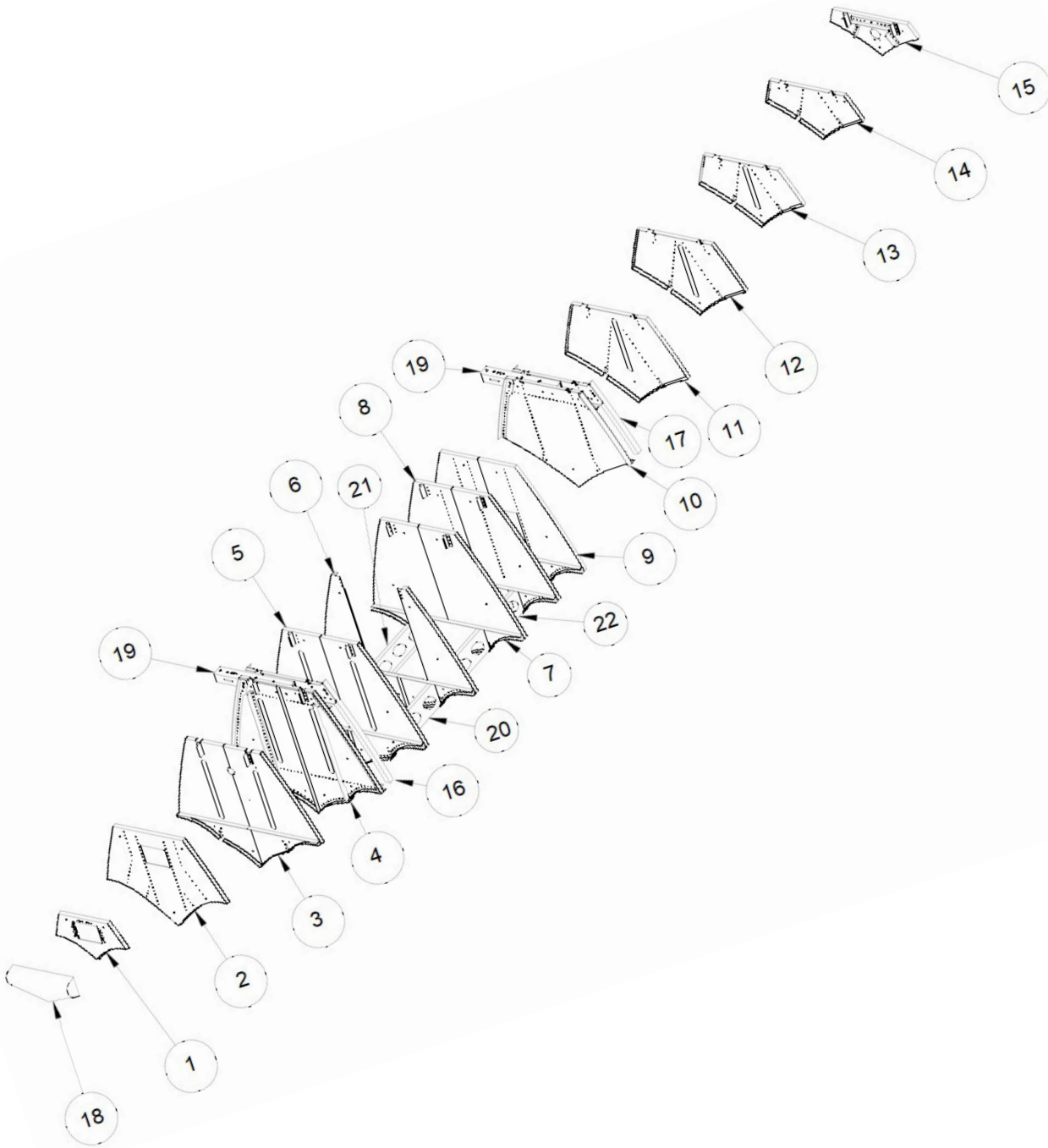

ITEM	QTY	PART NO.	PART DESCRIPTION
1	1	30A01000-329	ASSEMBLY, BULKHEAD 1, NOSE
2	1	30A01000-330	ASSEMBLY, BULKHEAD 3
3	1	30A01000-331	ASSEMBLY, BULKHEAD 4
4	1	30A01000-336	ASSEMBLY, BULKHEAD 5
5	1	30A01000-332	ASSEMBLY, BULKHEAD 6
6	1	30A01000-333	ASSEMBLY, BULKHEAD 7
7	1	34A01000-357	ASSEMBLY, BULKHEAD 8
8	1	1004914	ASSEMBLY, BULKHEAD 8, COMP
9	1	1004888	ASSEMBLY, BULKHEAD 9
10	1	30A01000-339	ASSEMBLY, BULKHEAD 10
11	1	30A01000-340	ASSEMBLY, BULKHEAD 11
12	1	30A01000-341	ASSEMBLY, BULKHEAD 12
13	1	30A01000-342	ASSEMBLY, BULKHEAD 13
14	1	34A01000-356	ASSEMBLY, BULKHEAD 15
15	1	34A01000-355	ASSEMBLY, BULKHEAD 16
16	1	30A01000-354	PANEL SPREADER BAR FWD. ASSY.
	1	30A01155-031	PANEL – SPR. BAR
	1	30A01352-039	ANGLE – SIDE L.
	1	30A01352-040	ANGLE – SIDE R.
	2	6A01359-004	ANGLE
	1	AN4-5A	BOLT
	1	NAS1149F0463P	WASHER
	1	MS21044N4	NUT
17	1	30A01000-353	PANEL SPREADER BAR AFT. ASSY.
	1	30A01155-031	PANEL – SPR. BAR
	1	30A01352-033	ANGLE – SIDE L.
	1	30A01352-034	ANGLE – SIDE R.
	2	30A01156-125	ANGLE
	1	AN4-5A	BOLT
	1	NAS1149F0463P	WASHER
	1	MS21044N4	NUT
18	1	30A01000-365	NOSE BUMPER (AMPHIBIAN)
	1	30S01739-001	NOSE BUMPER (SEAPLANE)
	2	30A01359-225	ANGLE, ATTACH NOSE BUMPER (AMPHIBIAN)
	1	30S01326-034	ANGLE (SEAPLANE)
	2	AN526-1032R10	SCREW (SEAPLANE)
19	1	30A03319-001	TUBE – SPR. BAR MOUNTING R.
	1	30A03319-002	TUBE – SPR. BAR MOUNTING L.
	6	AN5-24A	BOLT
	6	NAS1149D0532J	WASHER
	12	NAS1149D0563J	WASHER

ITEM	QTY	PART NO.	PART DESCRIPTION
	6	MS21044N5	NUT
20	2	34A01005-385	BAGGAGE REINFORCEMENT
	4	34A01340-173	ANGLE
	4	34A01340-174	ANGLE
21	2	34A01005-384	BAGGAGE REINFORCEMENT
	4	34A01340-173	ANGLE
	4	34A01340-174	ANGLE
22	2	34A01005-383	BAGGAGE REINFORCEMENT
	4	34A01340-173	ANGLE
	4	34A01340-174	ANGLE
23	1	34A01162-049	GUNWALL CAP (OUTBRD L) (NOT SHOWN)
	1	34A01162-050	GUNWALL CAP (OUTBRD R) (NOT SHOWN)



## BULKHEAD #1

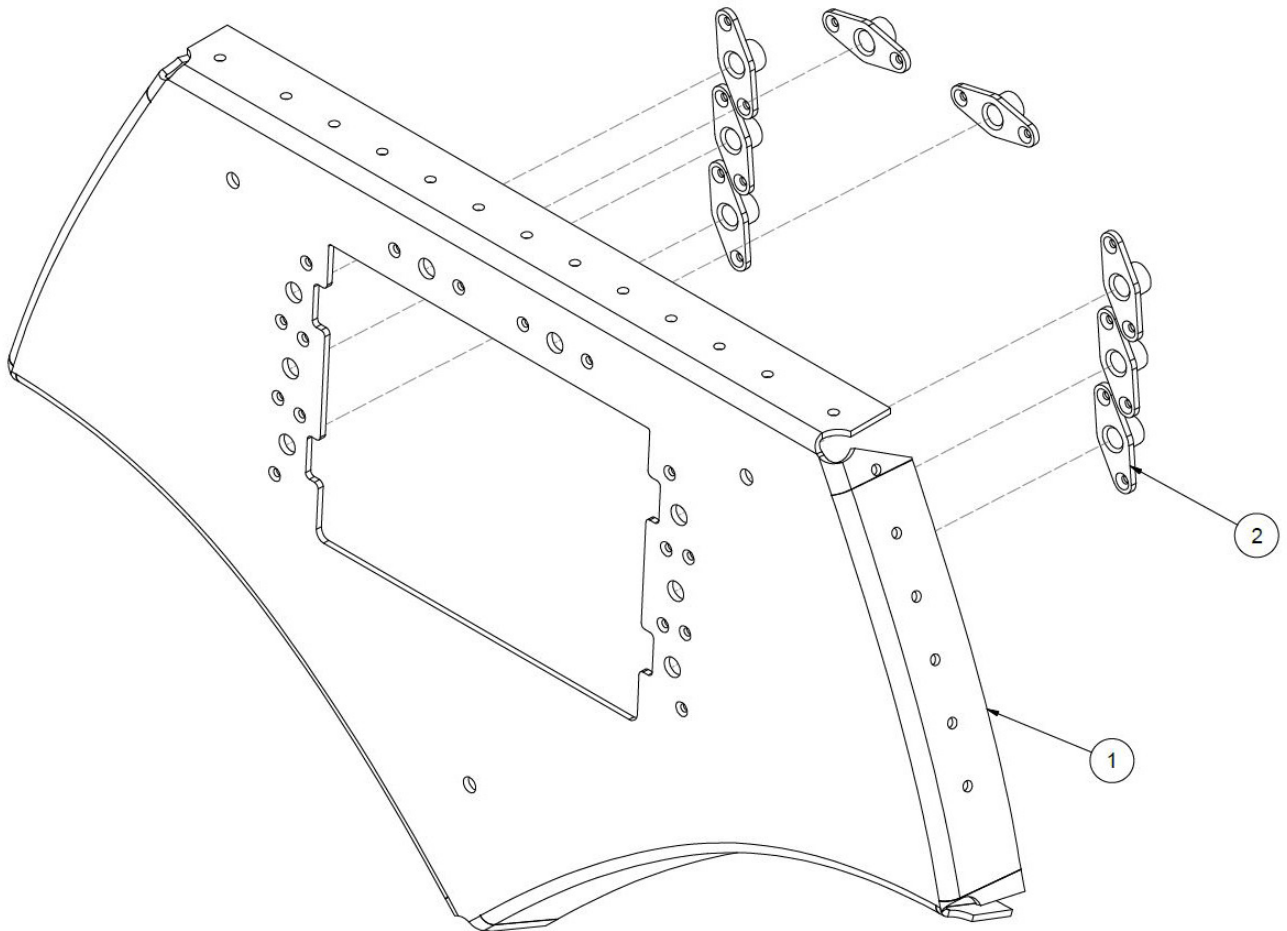

ITEM	QTY	PART NO.	PART DESCRIPTION
-	1	30A01000-329	ASSEMBLY, BULKHEAD, NOSE
1	1	30A01155-029	BULKHEAD #1
2	8	MS21078-4	NUT PLATE
3	1	30S01158-263	COVER – BULKHEAD SEAPLANE (NOT SHOWN)

### BULKHEAD #3

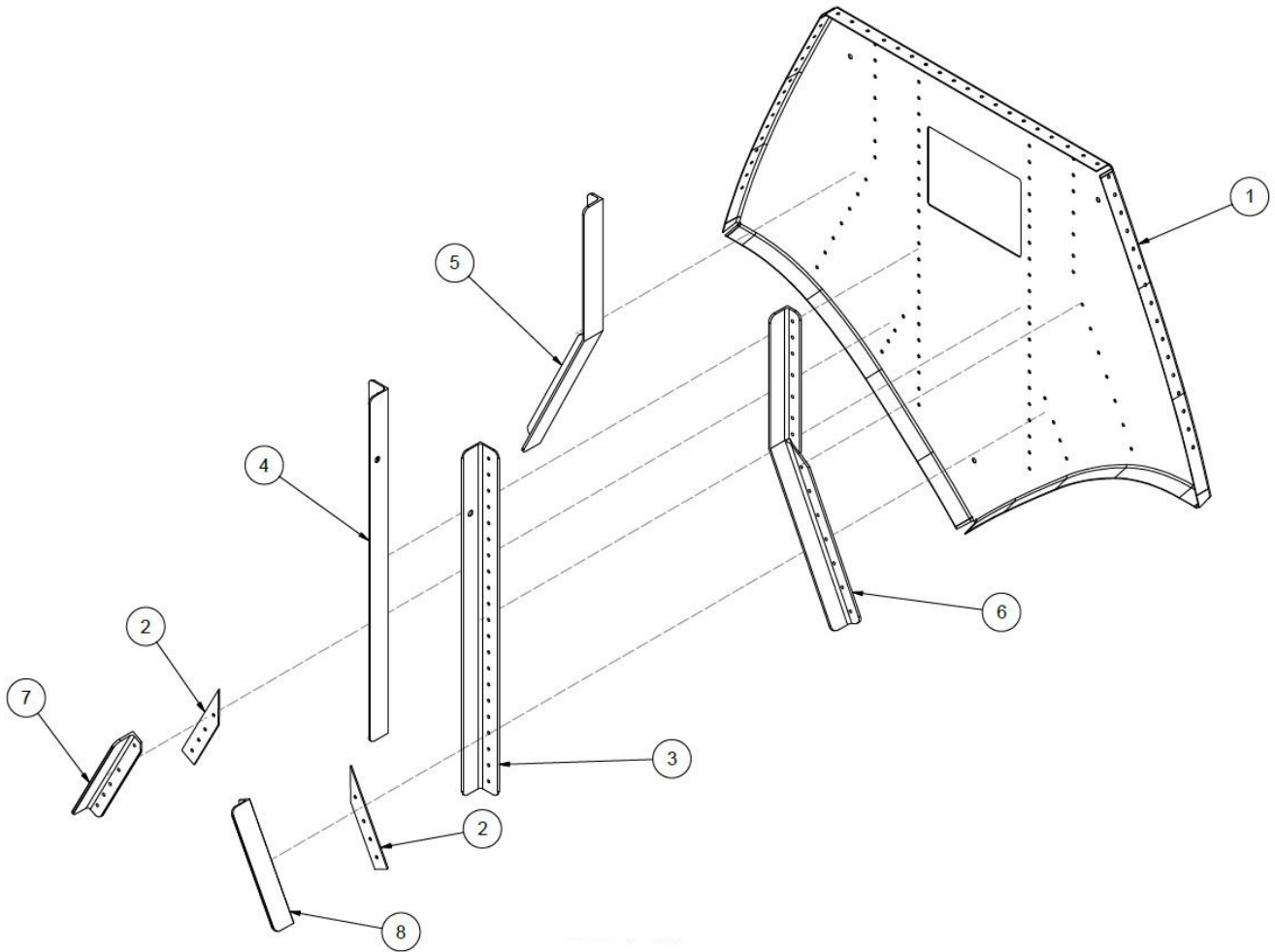

ITEM	QTY	PART NO.	PART DESCRIPTION
-	1	30A01000-330	ASSEMBLY, BULKHEAD 3
1	1	30A01158-208	PANEL, BULKHEAD 3
2	2	30A01163-072	ANGLE, SHIM, BULKHEAD #3
3	1	30A01326-020	ANGLE, NOSE BOX, BULK 3
4	1	30A01326-021	ANGLE NOSE BOX, BULK #3
5	1	30A01359-211	ANGLE, BULKHEAD 3
6	1	30A01359-212	ANGLE, BULKHEAD 3
7	1	30A01359-213	ANGLE, BULKHEAD 3
8	1	30A01359-214	ANGLE, BULKHEAD 3
9	1	30S01158-264	COVER – BULKHEAD SEAPLANE (NOT SHOWN)

## BULKHEAD #4

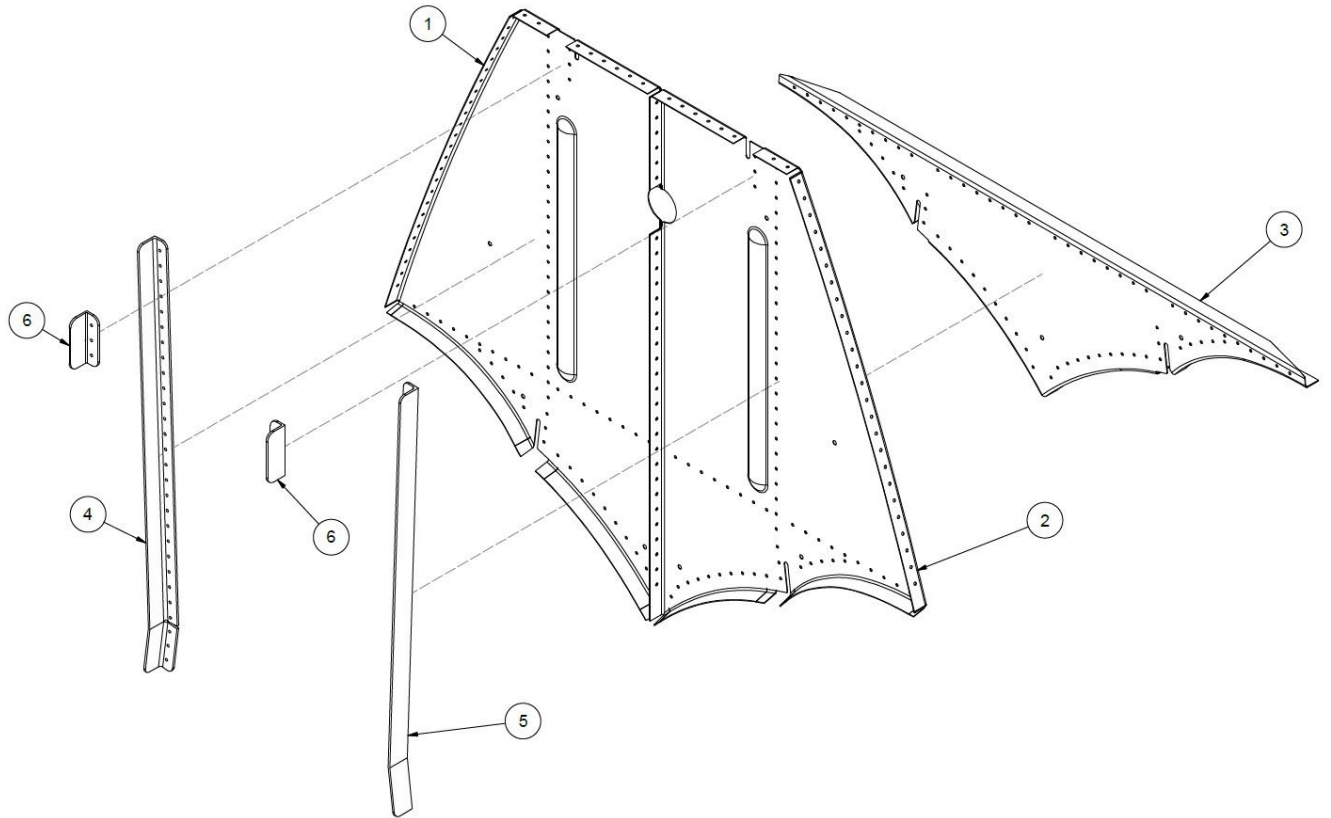

ITEM	QTY	PART NO.	PART DESCRIPTION
-	1	30A01000-331	ASSEMBLY, BULKHEAD 4
1	1	30A01158-209	BULKHEAD #4, LH
2	1	30A01158-210	BULKHEAD #4, RH
3	1	30A01158-222	SUPPORT - BULKHEAD #4
4	1	30A01359-223	ANGLE, BULKHEAD #4, RH
5	1	30A01359-224	ANGLE, BULKHEAD #4, LT
6	2	6A01359-004	ANGLE, ATTACH, TOP RAIL

## BULKHEAD #5

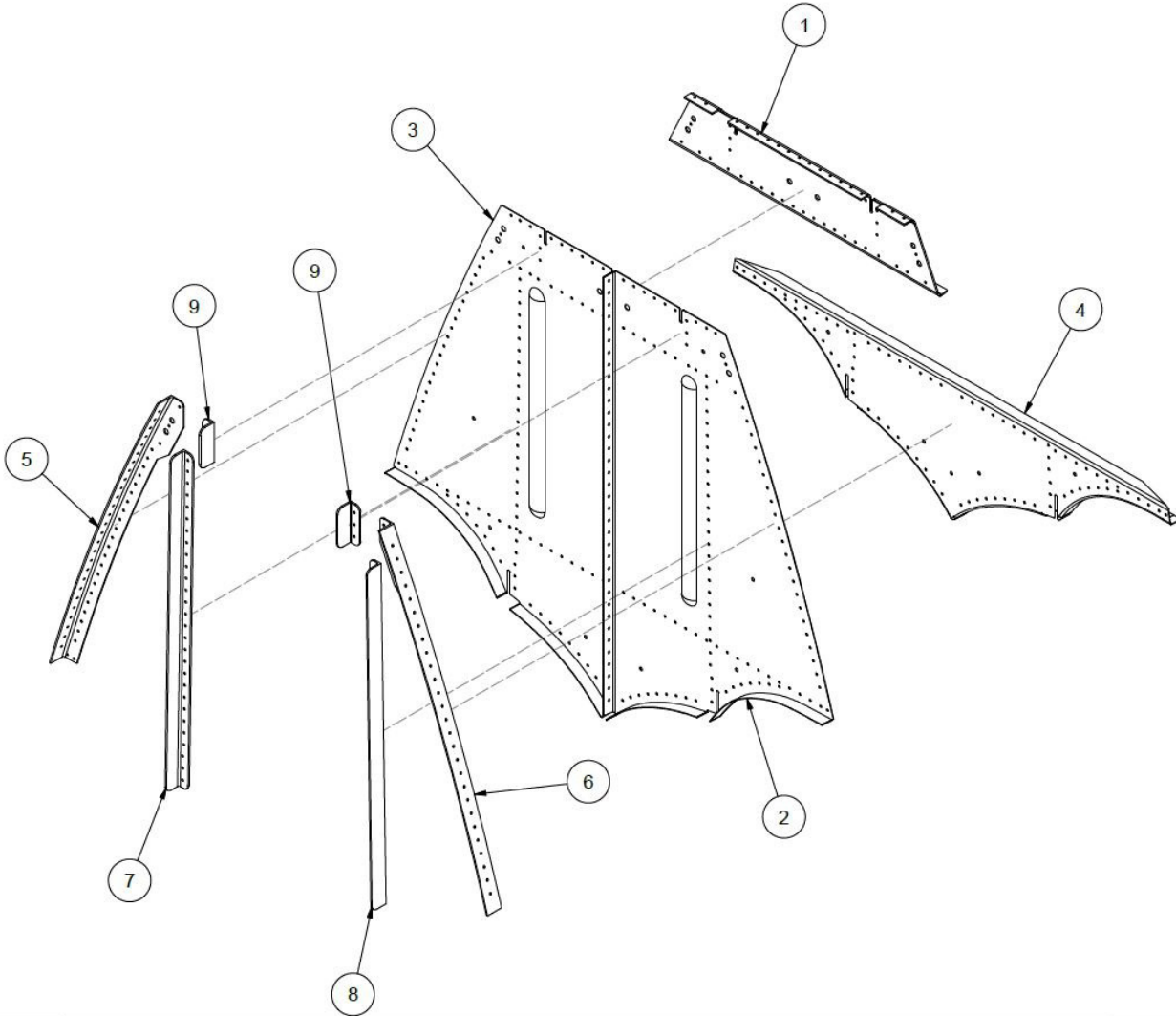

ITEM	QTY	PART NO.	PART DESCRIPTION
-	1	30A01000-336	ASSEMBLY, BULKHEAD 5
1	1	30A01155-032	PANEL, SPREADER BAR, BH 5 & 10
2	1	30A01158-211	BULKHEAD #5 - LH - FORMED
3	1	30A01158-212	BULKHEAD #5 - RH - FORMED
4	1	30A01158-223	SUPPORT - BULKHEAD #5
5	1	30A01352-037	ANGLE, SIDE, BULKHEAD 5
6	1	30A01352-038	ANGLE, SIDE, BULKHEAD 5
7	1	30A01359-221	ANGLE, BULKHEAD STN. #5
8	1	30A01359-222	ANGLE, BULKHEAD STN. #5
9	2	6A01359-004	ANGLE, ATTACH, TOP RAIL

## BULKHEAD #6

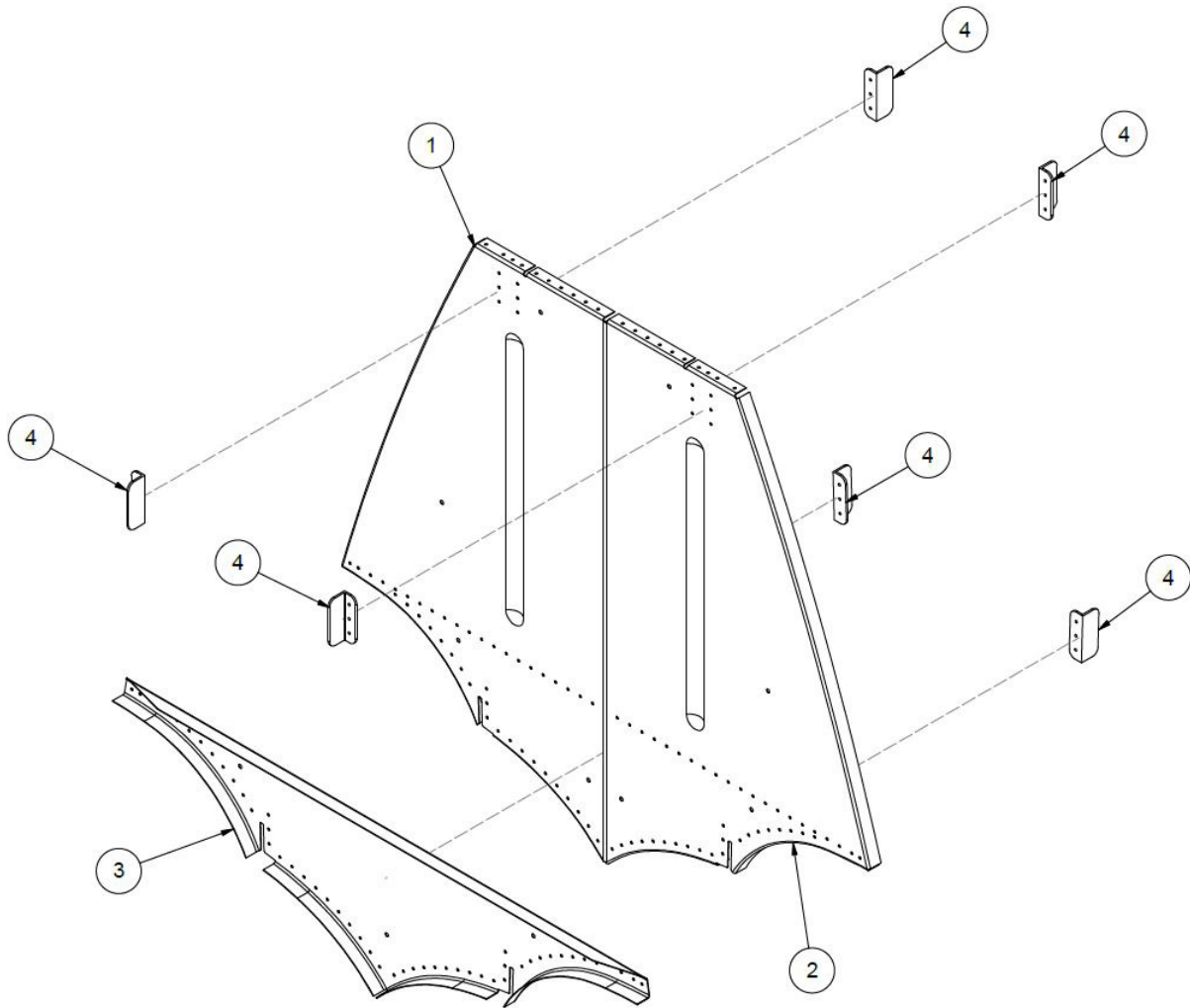

ITEM	QTY	PART NO.	PART DESCRIPTION
-	1	30A01000-332	ASSEMBLY, BULKHEAD 6
1	1	30A01158-213	BULKHEAD #6 - LH - FORMED
2	1	30A01158-214	BULKHEAD #6 - RH - FORMED
3	1	30A01158-224	SUPPORT - BULKHEAD #6
4	6	6A01359-004	ANGLE, ATTACH, TOP RAIL

### BULKHEAD #7

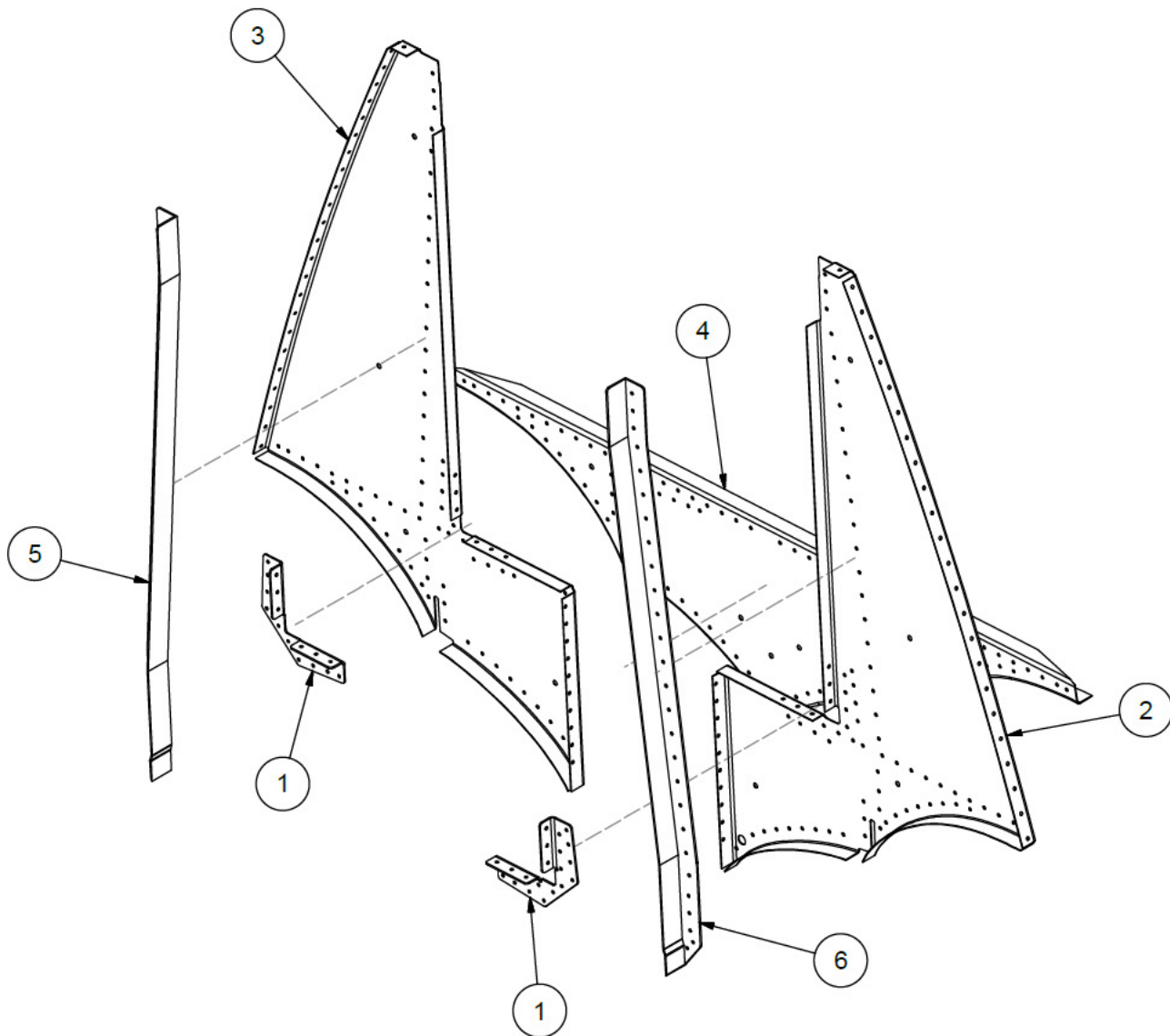

ITEM	QTY	PART NO.	PART DESCRIPTION
-	1	30A01000-333	BULKHEAD ASSEMBLY #7
1	2	1001110	DOUBLER - SUPPORT - LH/RH BULKHEAD #7
2	1	30A01158-215	BULKHEAD - #7, LH
3	1	30A01158-216	BULKHEAD - #7, RH
4	1	30A01158-225	SUPPORT - BULKHEAD #7
5	1	30A01326-036	ANGLE - BULKHEAD #7
6	1	30A01326-037	ANGLE - BULKHEAD #7

### BULKHEAD #8

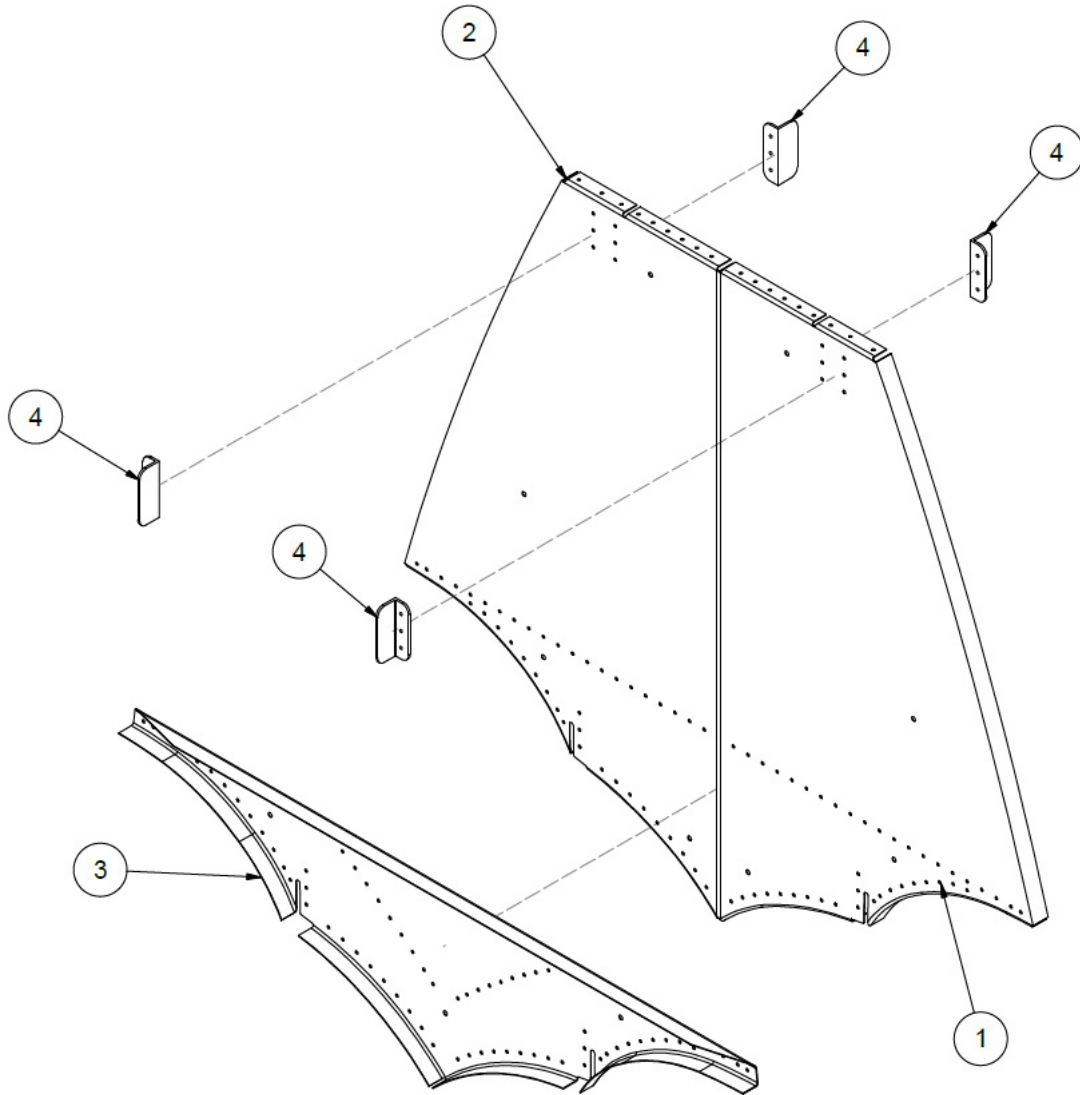

ITEM	QTY	PART NO.	PART DESCRIPTION
-	1	34A01000-357	BULKHEAD STATION #8 ASSY
1	1	34A01158-239	BULKHEAD #8
2	1	34A01158-240	BULKHEAD #8
3	1	34A01158-241	SUPPORT - BULKHEAD, #8
4	4	6A01359-004	ANGLE, ATTACH, TOP RAIL

### BULKHEAD #8

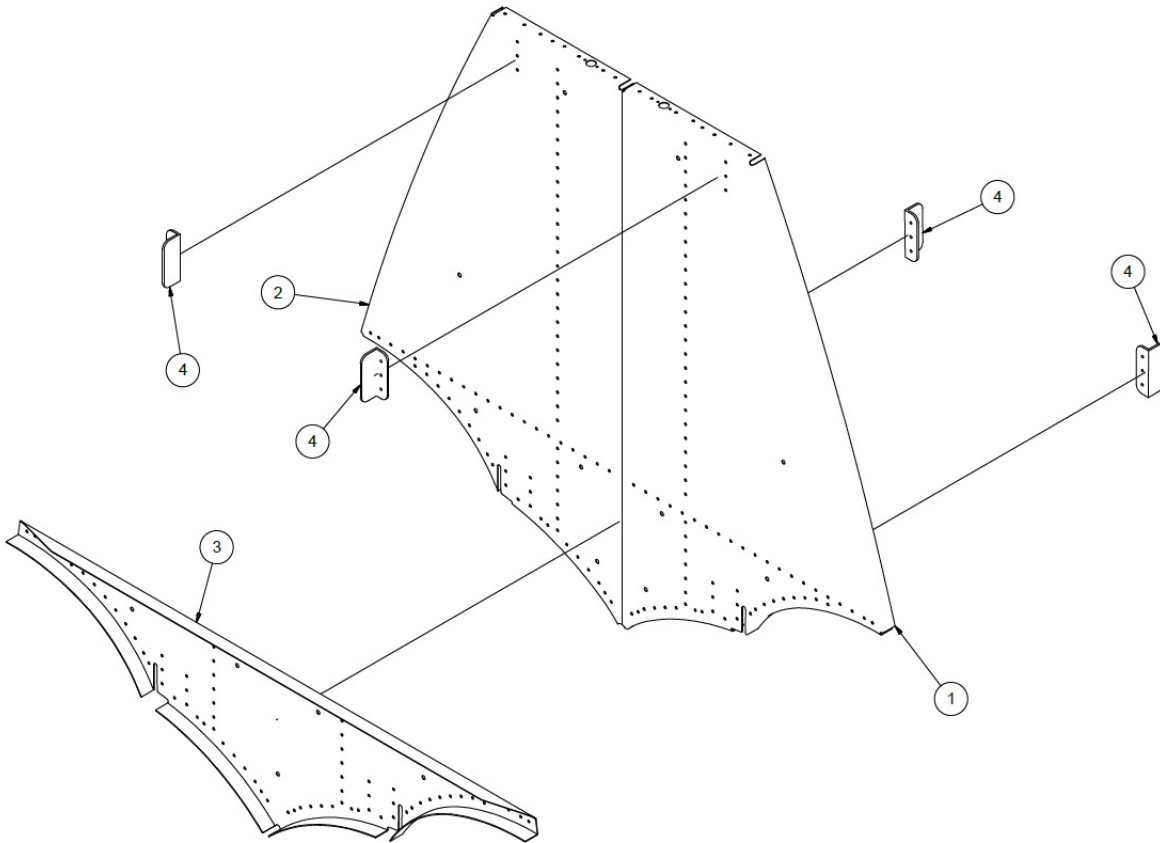

ITEM	QTY	PART NO.	PART DESCRIPTION
-	1	1004914	ASSEMBLY, BULKHEAD 8, 3000 3450 COMP
1	1	1004912	BULKHEAD, #8, LH, 3000 3450
2	1	1004913	BULKHEAD, #8, RH, 3000 3450
3	1	1004915	SUPPORT, BULKHEAD #8, 3000 3450
4	4	6A01359-004	ANGLE - SUPPORT



### BULKHEAD #9

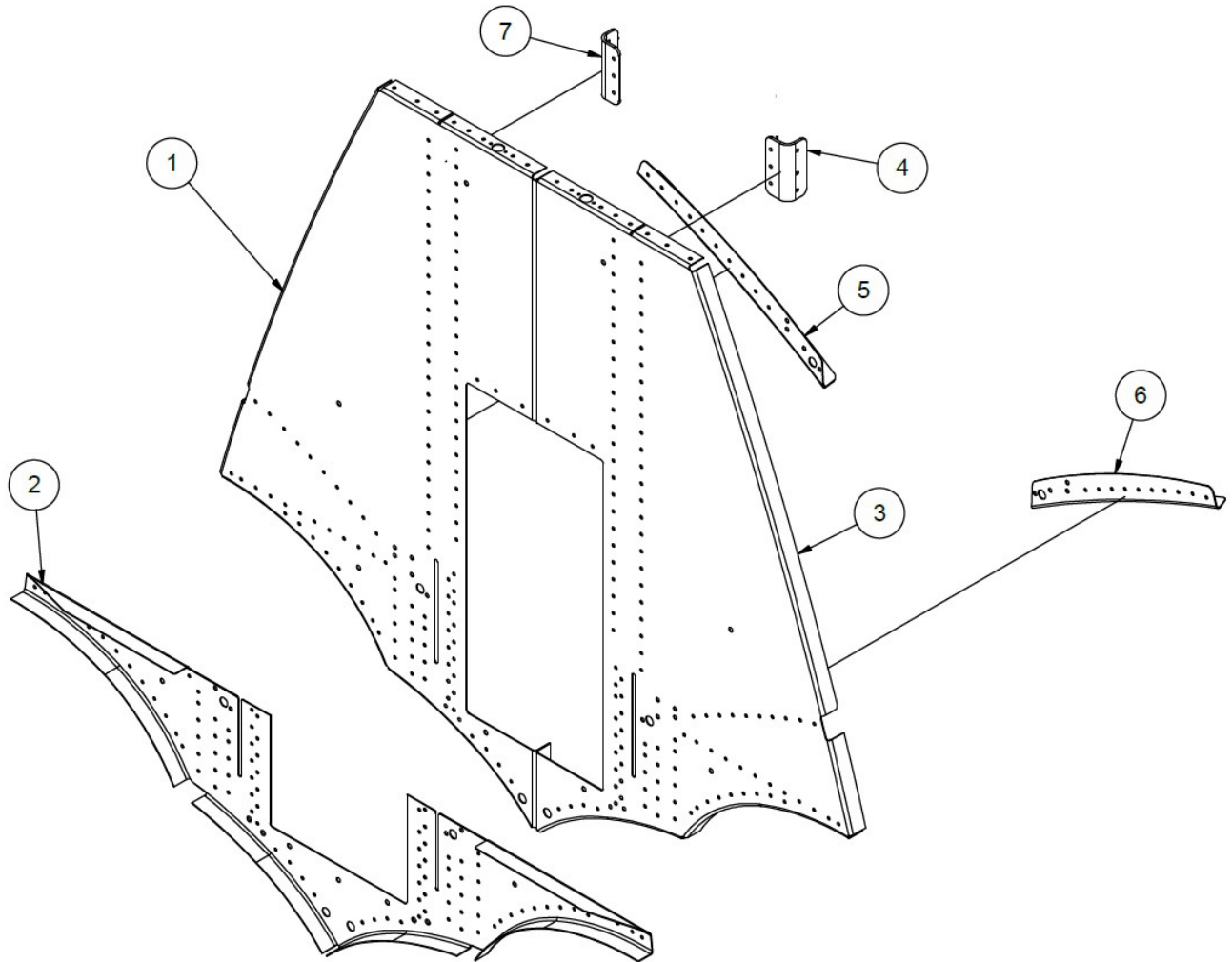

ITEM	QTY	PART NO.	PART DESCRIPTION
-	1	1004888	ASS'Y BULKHEAD #9
1	1	1004889	BULKHEAD, #9, RIGHT, 3000 3450
2	1	1004890	SUPPORT, RH, BULKHEAD #9
3	1	1004891	BULKHEAD, #9, LEFT, 3000 3450
4	1	1005519	ATTACH, ANGLE, TOP RAIL
5	1	1005581	ANGLE, ATTACH AFT
6	1	1005582	ANGLE, ATTACH AFT
7	1	1005611	ATTACH, ANGLE, TOP RAIL

## BULKHEAD #10

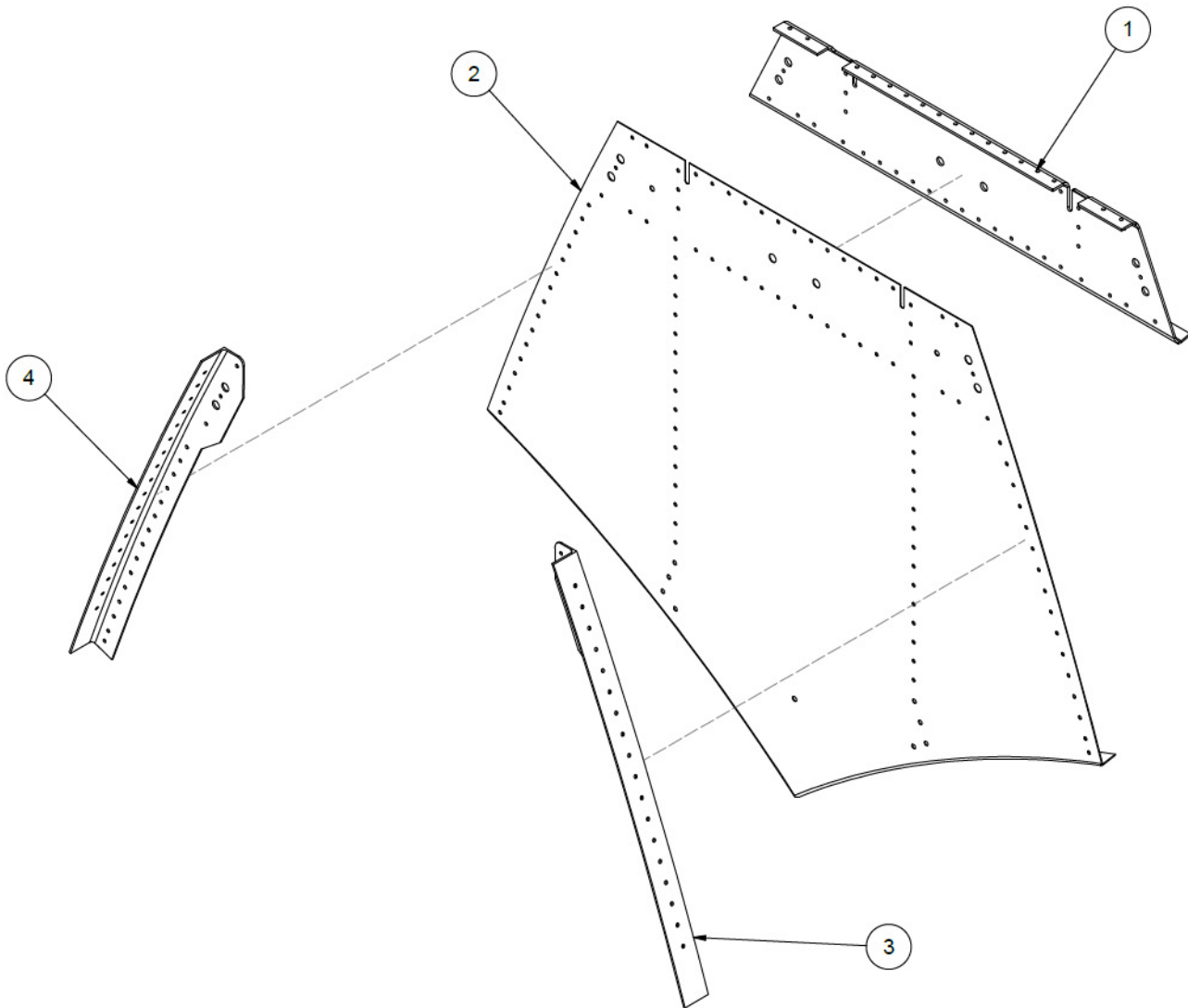

ITEM	QTY	PART NO.	PART DESCRIPTION
-	1	30A01000-339	ASSEMBLY, BULKHEAD 10 (AMPHIB)
-	1	30S01000-408	ASS'Y. BULKHEAD #10 (SEAPLANE ONLY)
1	1	30A01155-032	PANEL, SPREADER BAR, BH 5 & 10
2	1	30A01158-221	BULKHEAD #10
3	1	30A01352-035	ANGLE, SIDE, BULKHEAD 10
4	1	30A01352-036	ANGLE, SIDE, BULKHEAD 10
5	4	6A01359-004	ANGLE (SEAPLANE ONLY NOT SHOWN)
6	2	30S01340-180	ANGLE (SEAPLANE ONLY NOT SHOWN)

## BULKHEAD #11

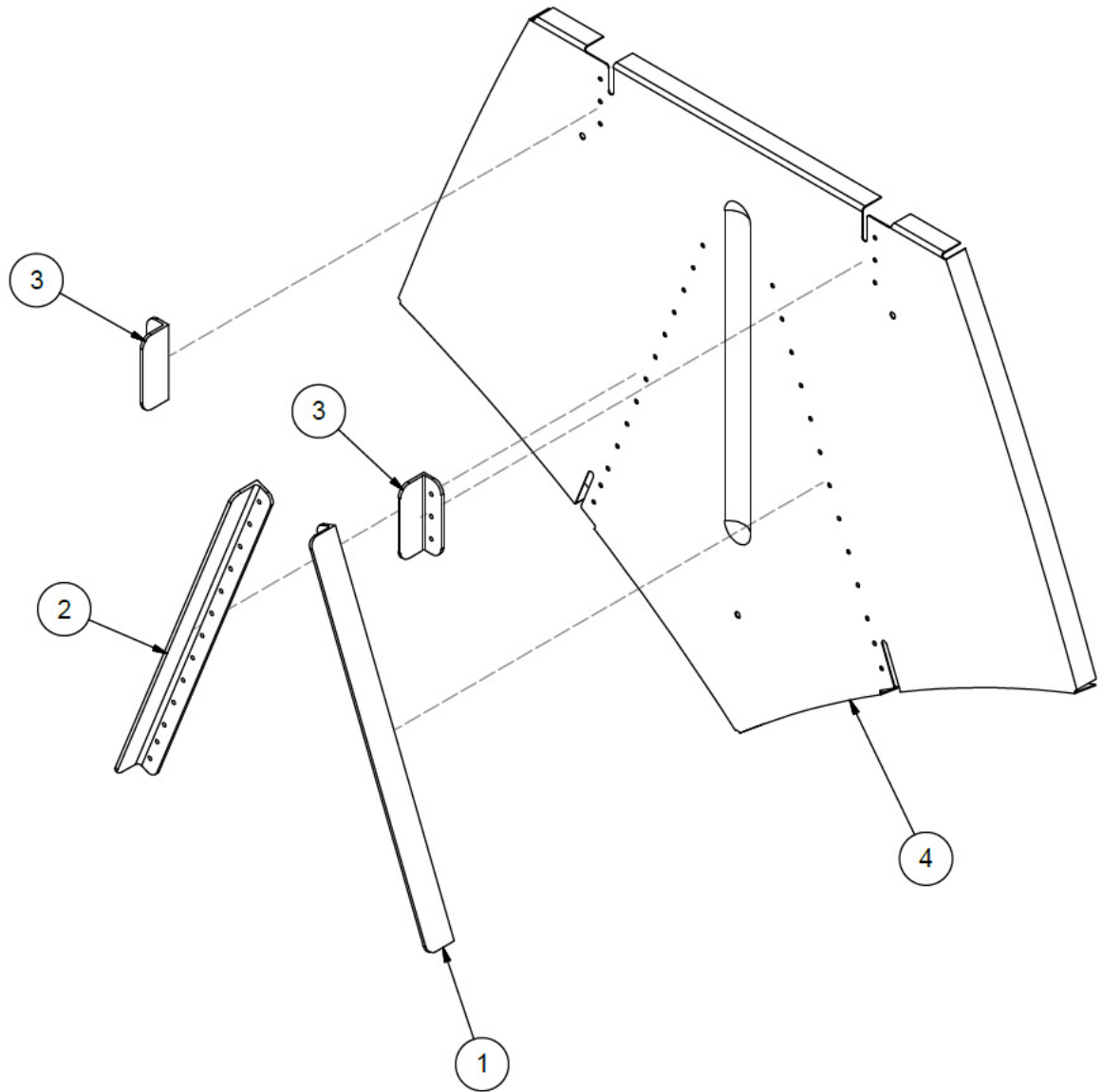

ITEM	QTY	PART NO.	PART DESCRIPTION
-	1	30A01000-340	BULKHEAD STAION #11 ASSY
1	1	30A01359-216	ANGLE - BULKHEAD #11 & #12
2	1	30A01359-217	ANGLE - BULKHEAD #11 & #12
3	2	6A01359-004	ANGLE, ATTACH, TOP RAIL
4	1	30A01158-204	BULKHEAD #11

### BULKHEAD #12

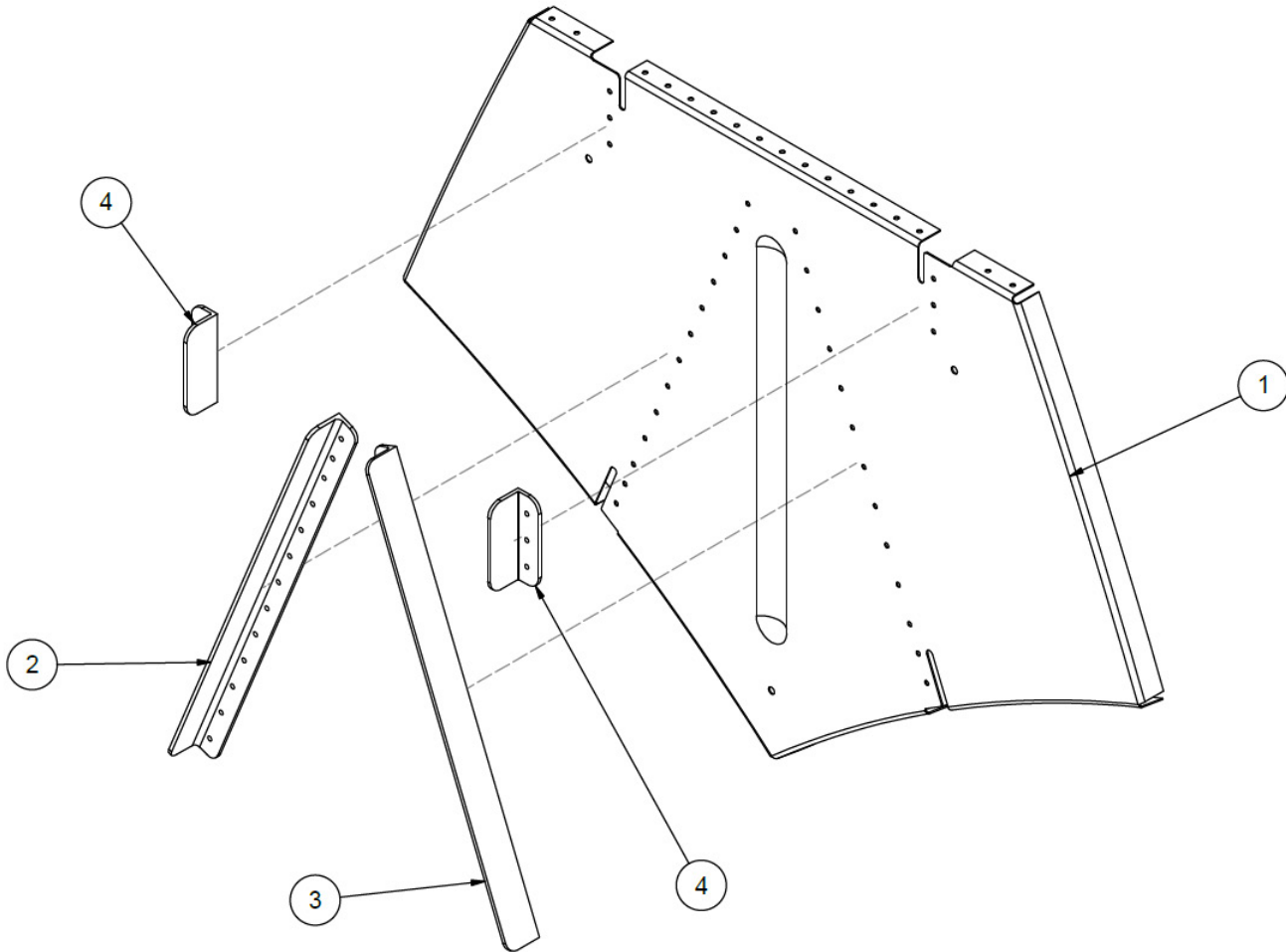

ITEM	QTY	PART NO.	PART DESCRIPTION
-	1	30A01000-341	30A01000-341
1	1	30A01158-205	BULKHEAD #12
2	1	30A01359-216	ANGLE - BULKHEAD #11 & #12
3	1	30A01359-217	ANGLE - BULKHEAD #11 & #12
4	2	6A01359-004	ANGLE, ATTACH, TOP RAIL

### BULKHEAD #13

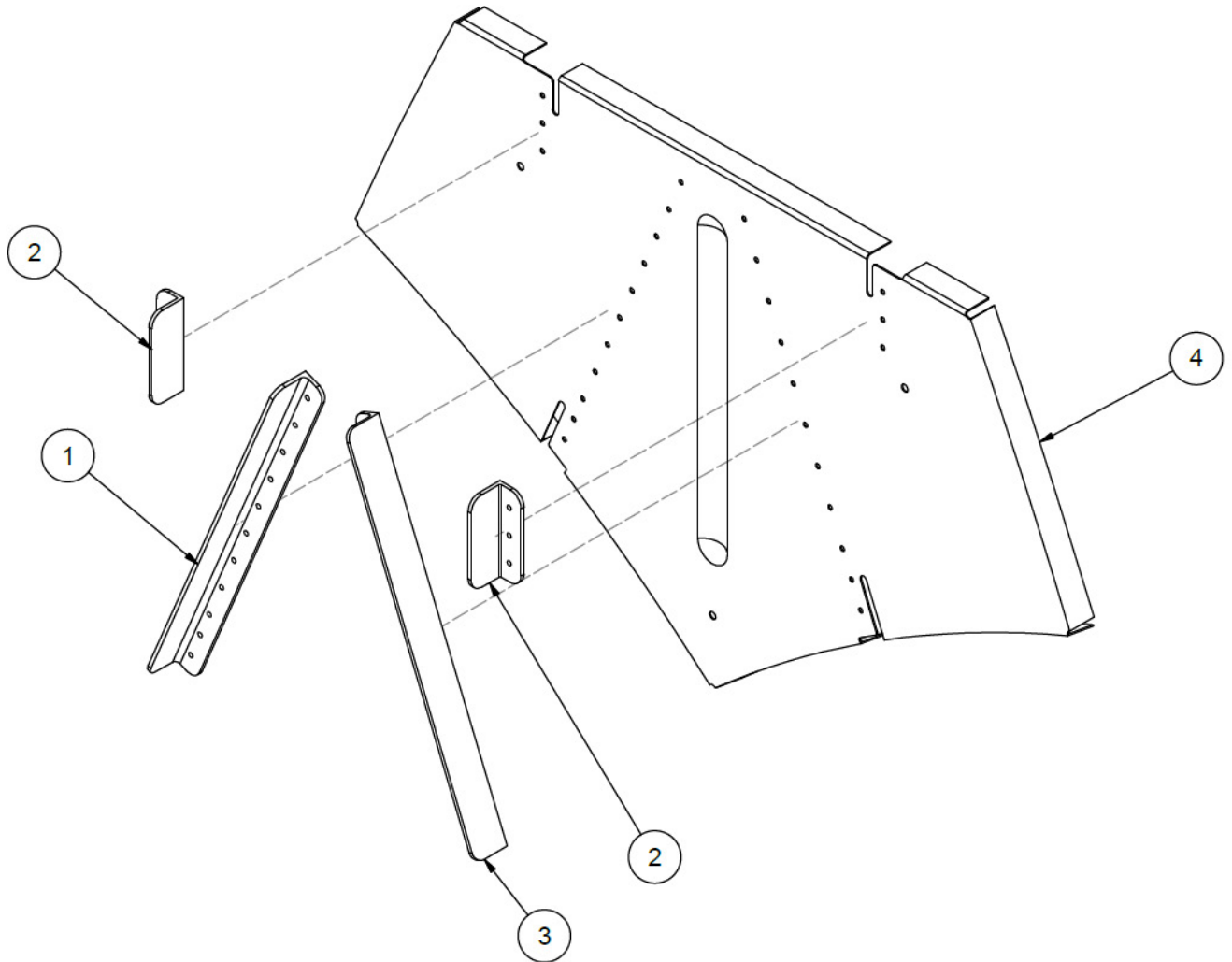

ITEM	QTY	PART NO.	PART DESCRIPTION
-	1	30A01000-342	BULKHEAD STATION #13 ASSY
1	1	30A01359-218	ANGLE - BULKHEAD #13
2	2	6A01359-004	ANGLE, ATTACH, TOP RAIL
3	1	30A01359-219	ANGLE - BULKHEAD #13
4	1	30A01158-206	BULKHEAD #13

### BULKHEAD #15

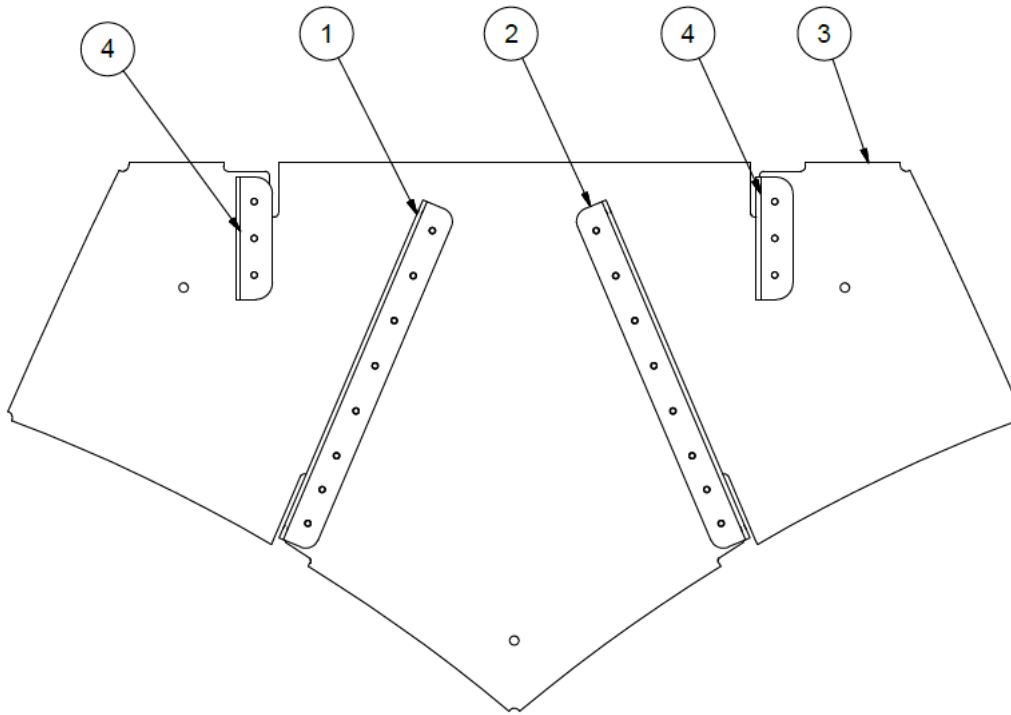

ITEM	QTY	PART NO.	PART DESCRIPTION
-	1	34A01000-356	BULKHEAD STN #15 ASSY
1	1	30A01359-215	ANGLE, BULKHEAD #15
2	1	30A01359-220	ANGLE, BULKHEAD #15
3	1	34A01158-242	BULKHEAD #15
4	2	6A01359-004	ANGLE - SUPPORT

### BULKHEAD #16

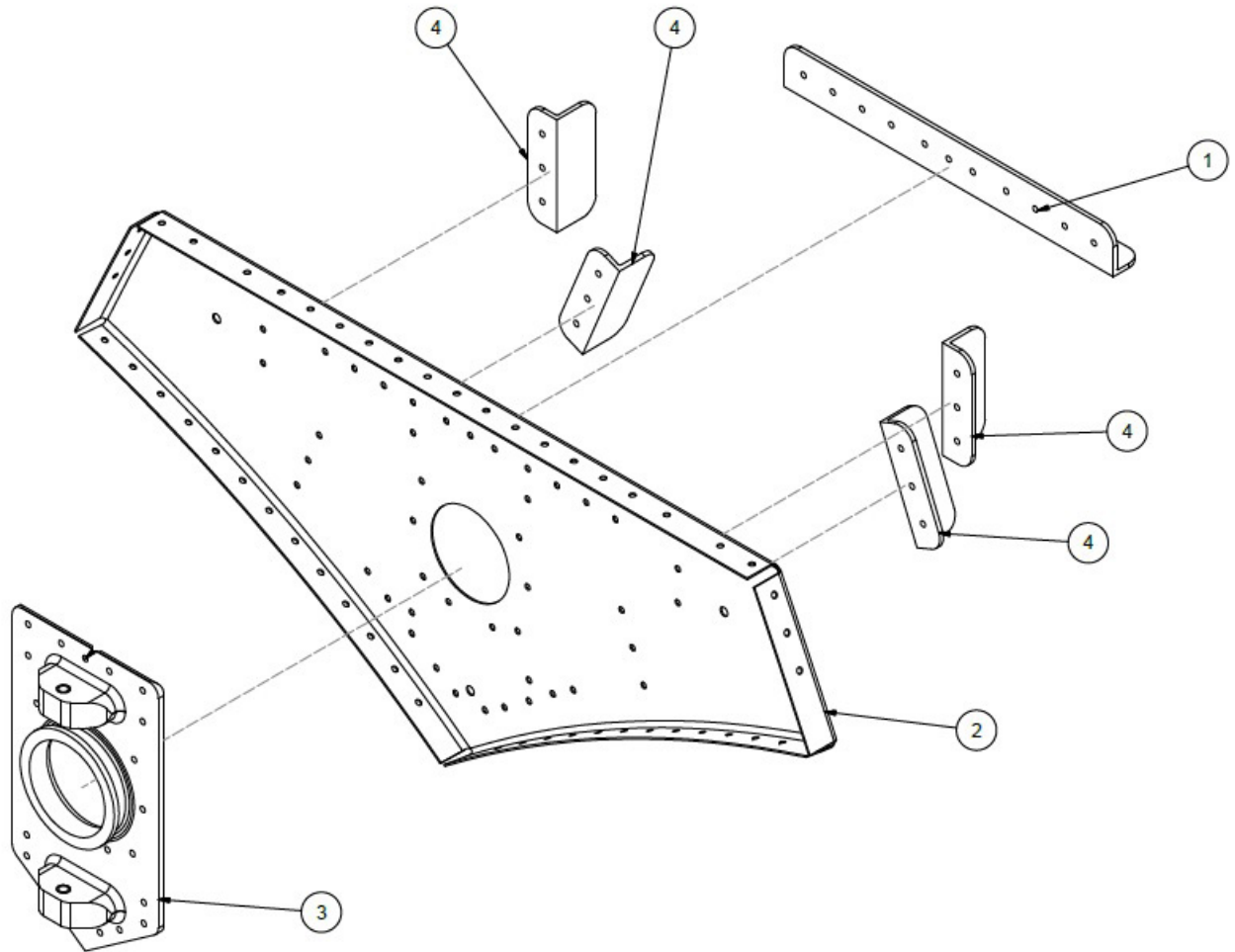

ITEM	QTY	PART NO.	PART DESCRIPTION
-	1	34A01000-355	ASSY, BULKHEAD STN, #16
1	1	30A01359-209	ANGLE, BULKHEAD #14, UPPER
2	1	34A01158-238	PANEL, BULKHEAD 16
3	1	4A01000-301	ASSEMBLY, MOUNT, PIVOT, WATER RUDDER
4	4	6A01359-004	ANGLE, ATTACH, TOP RAIL

THIS PAGE INTENTIONALLY LEFT BLANK



## SECTION 2 WHEEL WELL ASSEMBLY

### CONTENTS

WHEEL WELL AREA.....	30
WHEEL WELL ASSEMBLY - AMPHIBIAN.....	32

### WHEEL WELL AREA

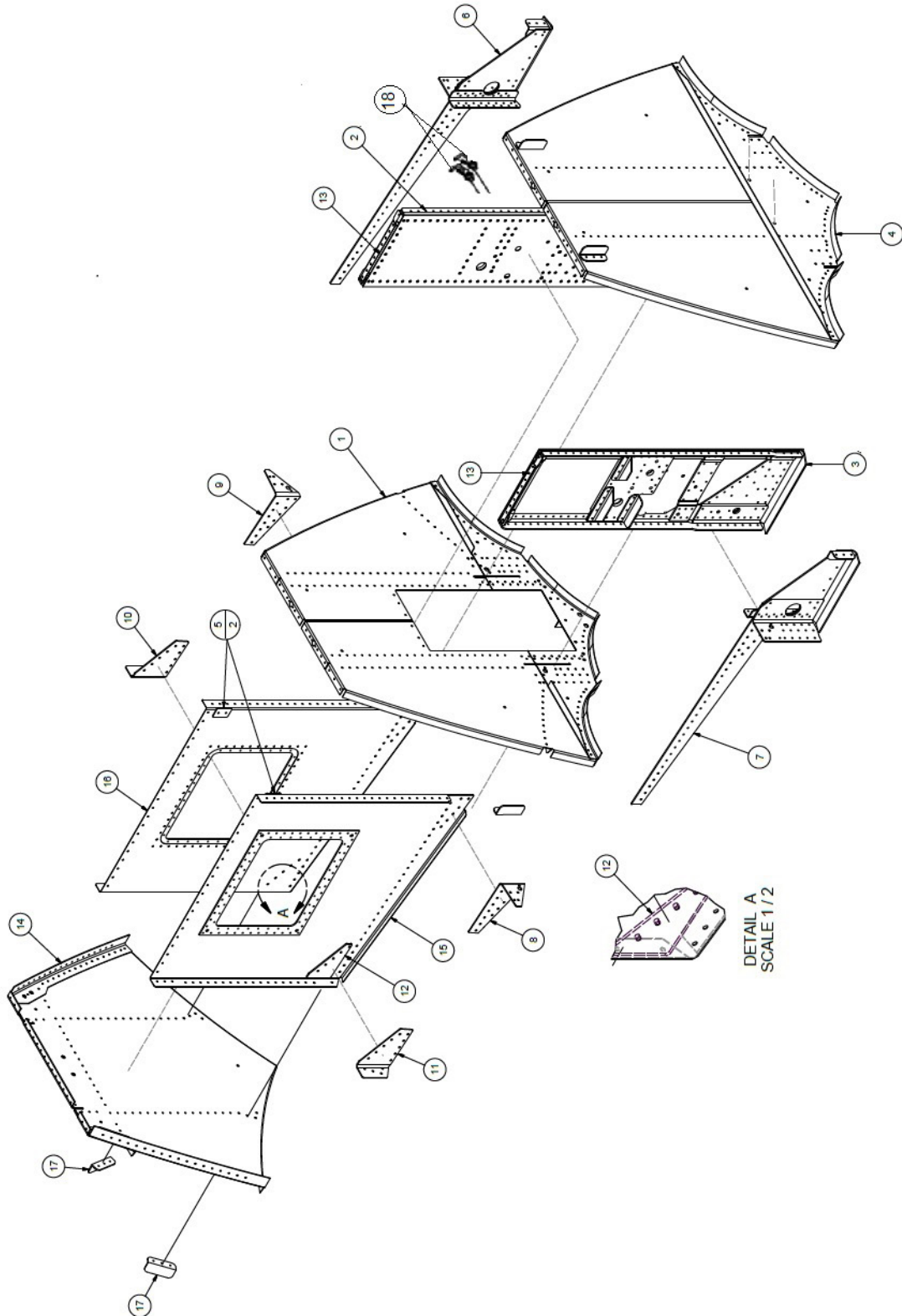

PARTS MANUAL  
3450 FLOATS ON CESSNA 206

ITEM	QTY	PART NO.	PART DESCRIPTION
-	1	1005530	ASSEMBLY, WHEEL WELL, CENTERED, 3450
1	1	1004888	ASS'Y BULKHEAD #9
2	1	1004893	ASSEMBLY, PANEL, MAIN GEAR
3	1	1004894	ASSEMBLY, PANEL, MAIN GEAR
4	1	1004914	ASSEMBLY, BULKHEAD 8, 3450 COMP
5	2	1005520	SPACER, ATTACH, ANGLE, TOP RAIL
6	1	1005523	ASSEMBLY, CARRY THRU STRAP, RIGHT
7	1	1005524	ASSEMBLY, CARRY THRU STRAP, LEFT
8	1	1005531	GUSSET, WHEEL WELL
9	1	1005532	GUSSET, WHEEL WELL
10	1	1005542	GUSSET, WHEEL WELL, REAR
11	1	1005543	GUSSET, WHEEL WELL, REAR
12	2	1005550	SPACER, GUSSET, CARRY-THRU
13	2	1005557	SPACER, ANGLE, PANEL, MAIN GEAR
14	1	30A01000-339	ASS'Y BULKHEAD #10
15	1	30A01000-348	ASSEMBLY, PANEL, SIDE, WHEEL WELL, RH
16	1	30A01000-349	ASSEMBLY, PANEL, SIDE, WHEEL WELL, LH
17	4	6A01359-004	ANGLE, ATTACH, TOP RAIL
18	2	1005724	SWITCH, PROXIMITY

### WHEEL WELL ASSEMBLY - AMPHIBIAN

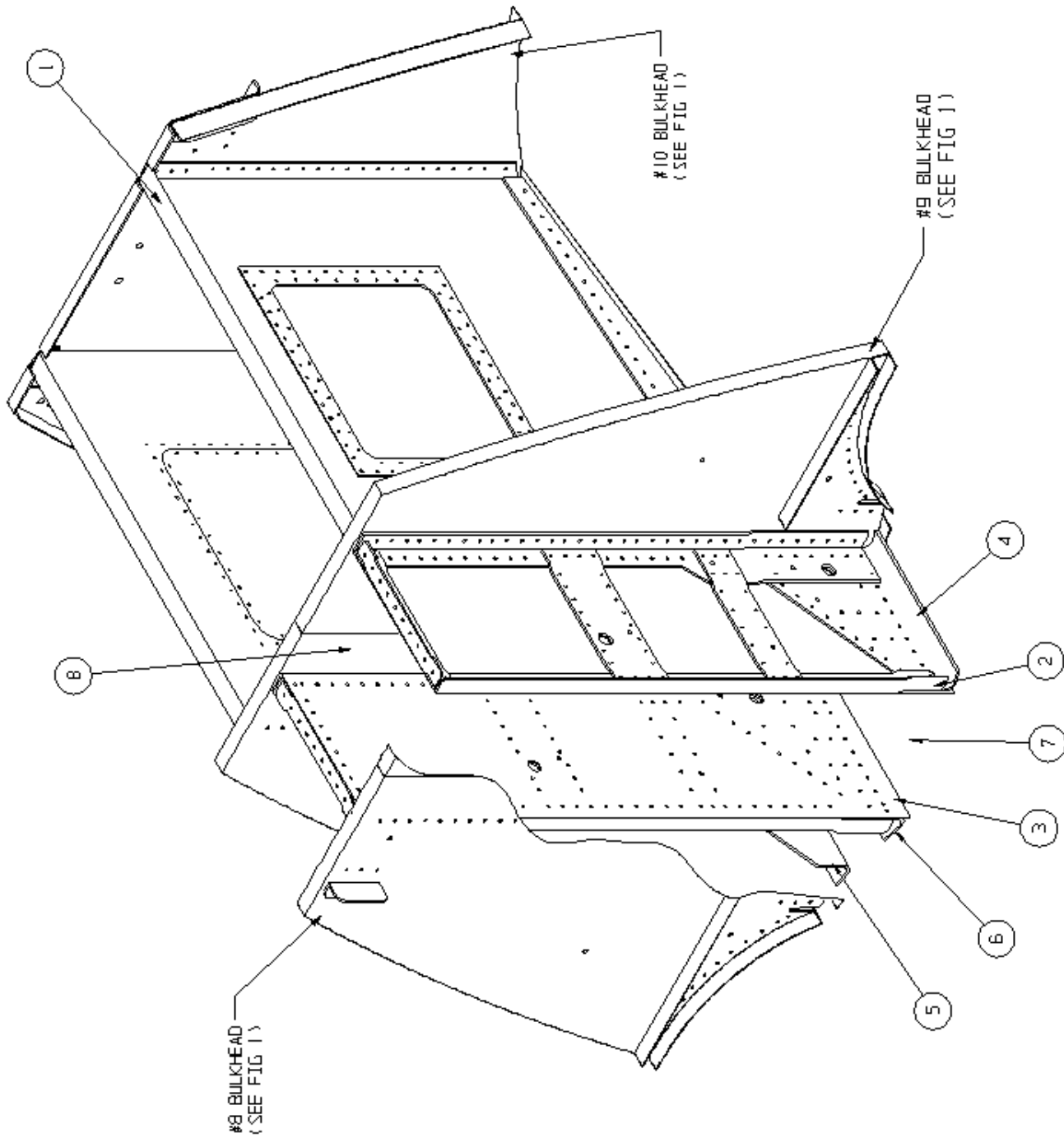

PARTS MANUAL  
3450 FLOATS ON CESSNA 206

ITEM	QTY	PART NO.	PART DESCRIPTION
1 LT.	1	30A01000-349	ASS'Y. WHEELWELL HALF L.
	1	30A01158-235	PANEL – FORMED L.
	1	13A01156-124	RING – COVER REINFORCEMENT
	1	21A01004-101	COVER
	28	AN526-632R6	SCREW
1 RT.	1	30A01000-348	ASS'Y. WHEELWELL HALF R.
	1	30A01158-234	PANEL – FORMED R.
	1	13A01156-124	RING – COVER REINFORCEMENT
	1	21A01004-101	COVER
	28	AN526-632R6	SCREW
2	1	30A01000-345	ASS'Y. WHEELWELL PANEL – OUTBR'D L.
	1	30A01000-350	ASS'Y. WHEELWELL PANEL – OUTBR'D R.
3	1	30A01000-347	ASS'Y. WHEELWELL PANEL – INBR'D L.
	1	30A01000-346	ASS'Y. WHEELWELL PANEL – INBR'D R.
4	1	30A01156-139	CARRY-THRU STRAP OUTBR'D L.
	1	30A01156-142	CARRY-THRU STRAP OUTBR'D R.
5	1	30A01156-141	CARRY-THRU STRAP INBR'D L.
	1	30A01156-140	CARRY-THRU STRAP INBR'D R.
6	1	30A01156-143	CARRY-THRU STRAP INBR'D L.
	1	30A01156-138	CARRY-THRU STRAP INBR'D R.
	1	30A01156-145	ANGLE – ATTACH AFT L.
	1	30A01156-150	ANGLE – ATTACH AFT R.
	1	30A01160-035	SHIM
	2	21A01326-015	ANGLE – ATTACH FWD
7	1	30A01000-287	SAND GUARD (NOT SHOWN) L.
	1	30A01000-288	SAND GUARD (NOT SHOWN) R.
	8	AN526-1032R8	SCREW
	4	MS21078-3	NUT PLATE
8	1	30A01569-002	MUD FLAP (NOT SHOWN)
	1	30A01150-141	REINFORCEMENT

THIS PAGE INTENTIONALLY LEFT BLANK

## SECTION 3 SKINS, STIFFENERS, & PADDLE

### CONTENTS

STIFFENERS .....	36
BOTTOM SKINS, DOUBLERS, & PADDLE - AMPHIBIAN .....	38
BOTTOM SKINS, DOUBLERS, & PADDLE - SEAPLANE .....	40
RIGHT FLOAT SIDE SKINS .....	42
LEFT FLOAT SIDE SKINS.....	43

## STIFFENERS

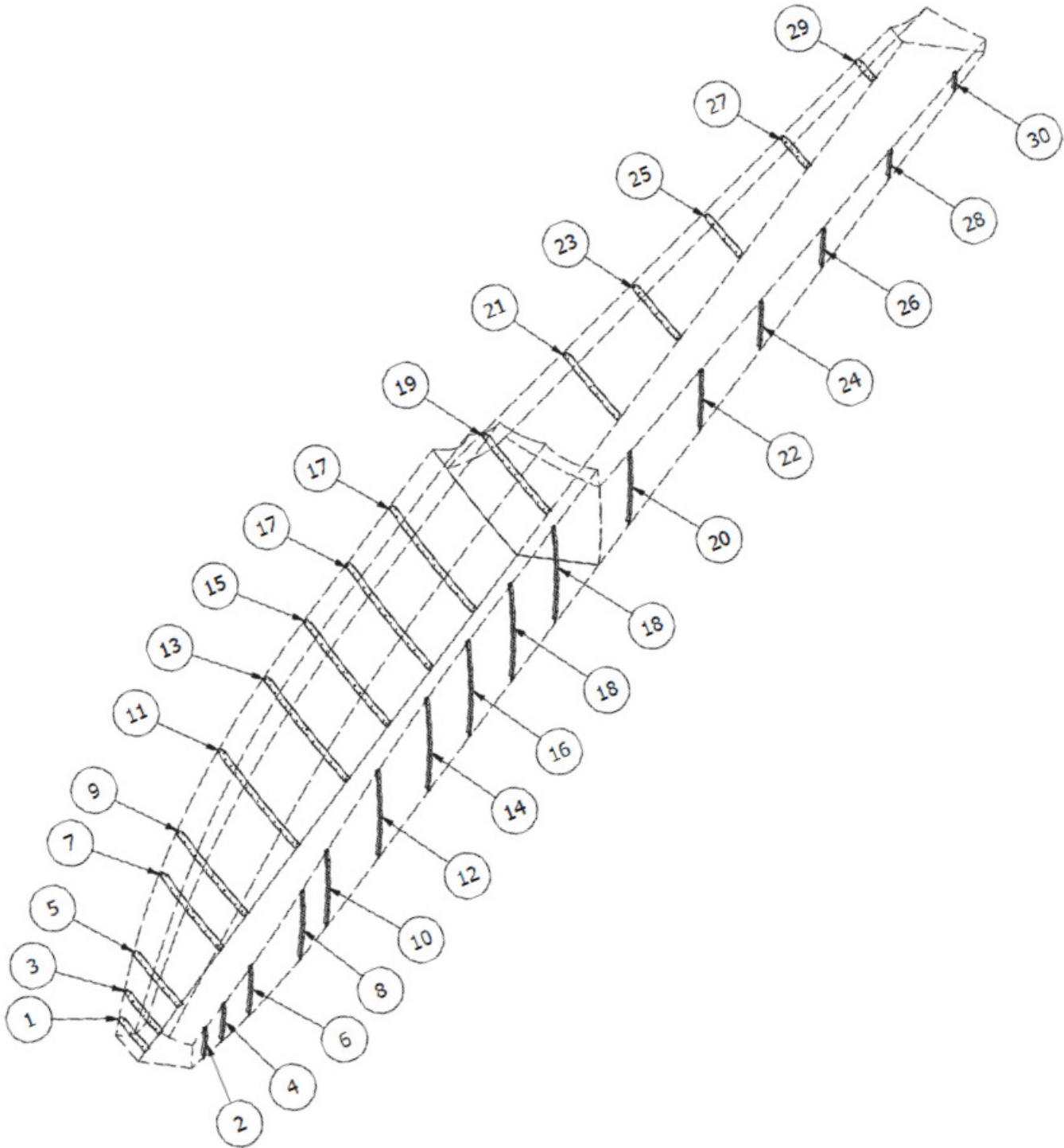

\*Glued stiffeners were discontinued after Service Letter 211. Riveted stiffeners are compatible with floats made prior to the service letter.



ITEM	QTY	PART NO.	PART DESCRIPTION
1	1	1011150	STIFFENER, SIDE SKIN, LH
2	1	1011151	STIFFENER, SIDE SKIN, RH
3	1	1011152	STIFFENER, SIDE SKIN, LH
4	1	1011153	STIFFENER, SIDE SKIN, RH
5	1	1011154	STIFFENER, SIDE SKIN, LH
6	1	1011155	STIFFENER, SIDE SKIN, RH
7	1	1011156	STIFFENER, SIDE SKIN, LH
8	1	1011157	STIFFENER, SIDE SKIN, RH
9	1	1011158	STIFFENER, SIDE SKIN, LH
10	1	1011159	STIFFENER, SIDE SKIN, RH
11	1	1011160	STIFFENER, SIDE SKIN, LH
12	1	1011161	STIFFENER, SIDE SKIN, RH
13	1	1011162	STIFFENER, SIDE SKIN, LH
14	1	1011163	STIFFENER, SIDE SKIN, RH
15	1	1011164	STIFFENER, SIDE SKIN, LH
16	1	1011165	STIFFENER, SIDE SKIN, RH
17	1	1011166	STIFFENER, SIDE SKIN, LH
18	1	1011167	STIFFENER, SIDE SKIN, RH
19	1	1011168	STIFFENER, SIDE SKIN, LH
20	1	1011169	STIFFENER, SIDE SKIN, RH
21	1	1011170	STIFFENER, SIDE SKIN, LH
22	1	1011171	STIFFENER, SIDE SKIN, RH
23	1	1011172	STIFFENER, SIDE SKIN, LH
24	1	1011173	STIFFENER, SIDE SKIN, RH
25	1	1011174	STIFFENER, SIDE SKIN, LH
26	1	1011175	STIFFENER, SIDE SKIN, RH
27	1	1011176	STIFFENER, SIDE SKIN, LH
28	1	1011177	STIFFENER, SIDE SKIN, RH
29	1	1011178	STIFFENER, SIDE SKIN, LH
30	1	1011179	STIFFENER, SIDE SKIN, RH

## BOTTOM SKINS, DOUBLERS, & PADDLE - AMPHIBIAN

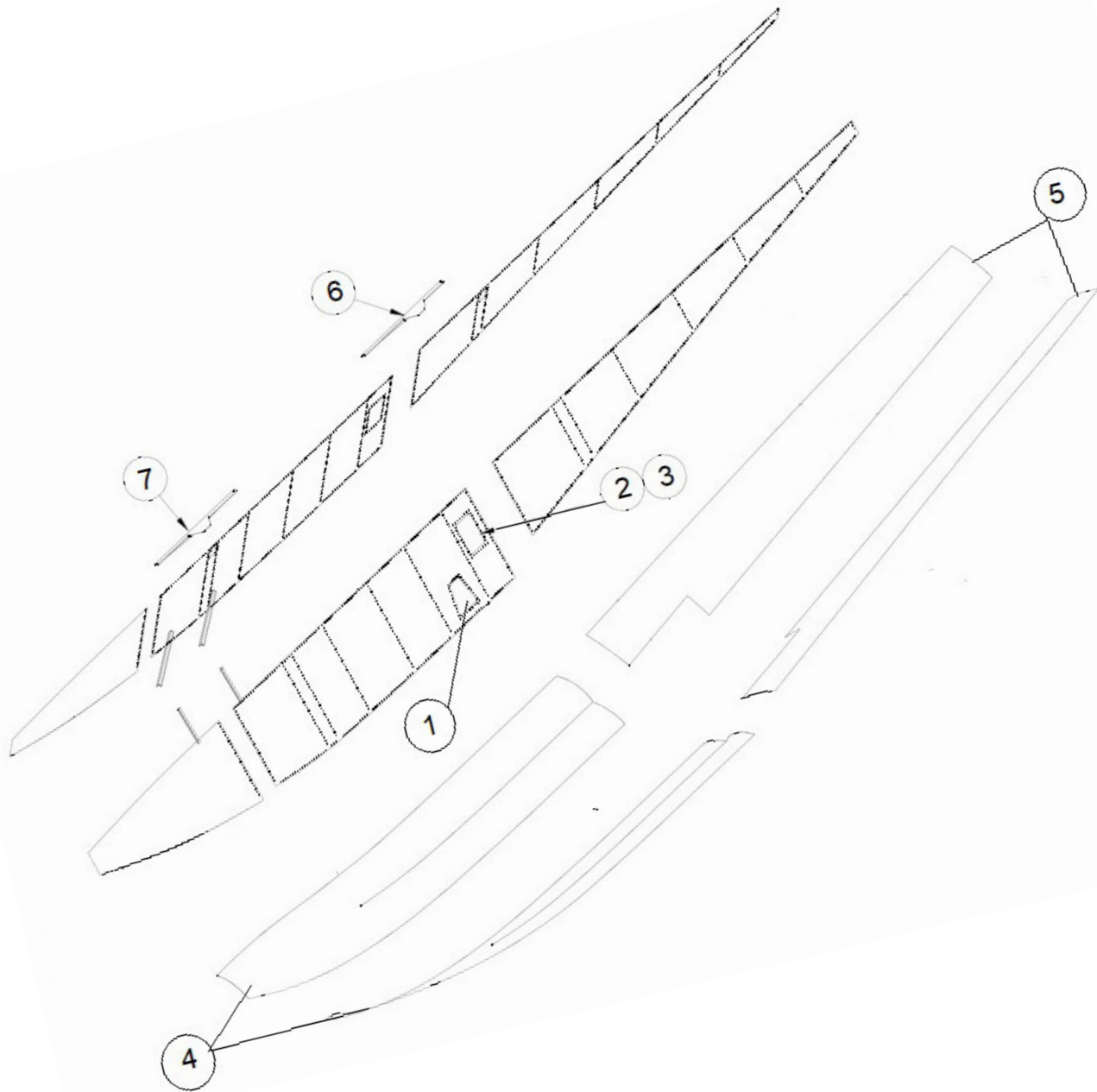

PARTS MANUAL  
3450 FLOATS ON CESSNA 206

ITEM	QTY	PART NO.	PART DESCRIPTION
1	1	30A01000-358	STEP – BOARDING
2	2	30A01156-144	REINFORCEMENT – COVER
3	2	21A01000-427	ASSY, COVER – INSP.
	2	21A01567-012	GASKET
	56	AN526-632R6	SCREW – ATTACH
4	1	30A01151-103	BOTTOM SKIN FWD L.
	1	30A01151-102	BOTTOM SKIN FWD R.
	2	34A01150-145	BOTTOM SKIN SPLICE – AFT
5	1	34A01148-039	BOTTOM SKIN AFTERBODY L.
	1	34A01148-040	BOTTOM SKIN AFTERBODY R.
	1	34A01150-147	DOUBLER, AFT, BOTTOM SKIN (NOT SHOWN)
	1	34A01150-148	DOUBLER, AFT, BOTTOM SKIN (NOT SHOWN)
	1	1005715	DOUBLER, WHEELWELL, AFT, BTM SKN (NOT SHOWN)
	1	1005716	DOUBLER, WHEELWELL, AFT, BTM SKN (NOT SHOWN)
6	1	34A01162-054	DOUBLER – GUNWALL AFT L.
	1	34A01162-055	DOUBLER – GUNWALL AFT R
7	1	30A01162-045	DOUBLER – GUNWALL FWD L.
	1	30A01162-046	DOUBLER – GUNWALL FWD R.
8	1	3A01158-093	BRACKET, CANOE PADDLE (NOT SHOWN)
	1	3A01503-001	CLIP (NOT SHOWN)
	1	6A01156-059	BRACKET, CANOE PADDLE STOP, LH (NOT SHOWN)
	1	6A01156-058	BRACKET, CANOE PADDLE STOP, RH (NOT SHOWN)
	2	0238-0068	PADDLE, 5-1/2 FT, BEAVER BRAND (NOT SHOWN)

## BOTTOM SKINS, DOUBLERS, & PADDLE - SEAPLANE

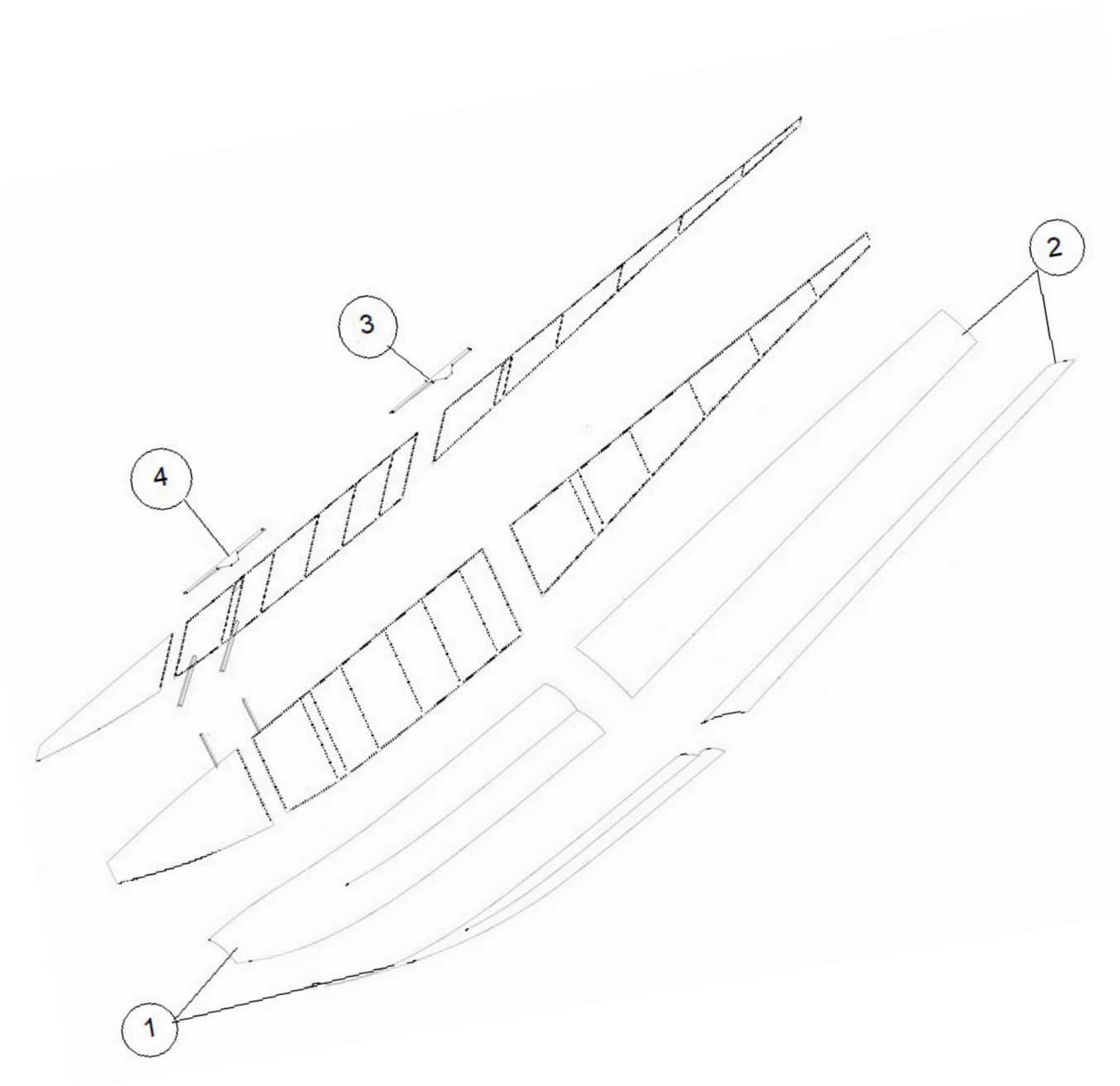

PARTS MANUAL  
3450 FLOATS ON CESSNA 206

ITEM	QTY	PART NO.	PART DESCRIPTION
1	1	30A01151-103	BOTTOM SKIN FWD L.
	1	30A01151-102	BOTTOM SKIN FWD R.
	2	34A01150-145	BOTTOM SKIN SPLICE – AFT
2	1	34S01148-041	BOTTOM SKIN AFTERBODY L.
	1	34S01148-042	BOTTOM SKIN AFTERBODY R.
3	1	34A01162-054	DOUBLER – GUNWALL AFT L.
	1	34A01162-055	DOUBLER – GUNWALL AFT R.
4	1	30A01162-045	DOUBLER – GUNWALL FWD L.
	1	30A01162-046	DOUBLER – GUNWALL FWD R.
5	1	3A01158-093	BRACKET, CANOE PADDLE (NOT SHOWN)
	1	3A01503-001	CLIP (NOT SHOWN)
	1	6A01156-059	BRACKET, CANOE PADDLE STOP, LH (NOT SHOWN)
	1	6A01156-058	BRACKET, CANOE PADDLE STOP, RH (NOT SHOWN)
	2	0238-0068	PADDLE, 5-1/2 FT, BEAVER BRAND (NOT SHOWN)

## RIGHT FLOAT SIDE SKINS

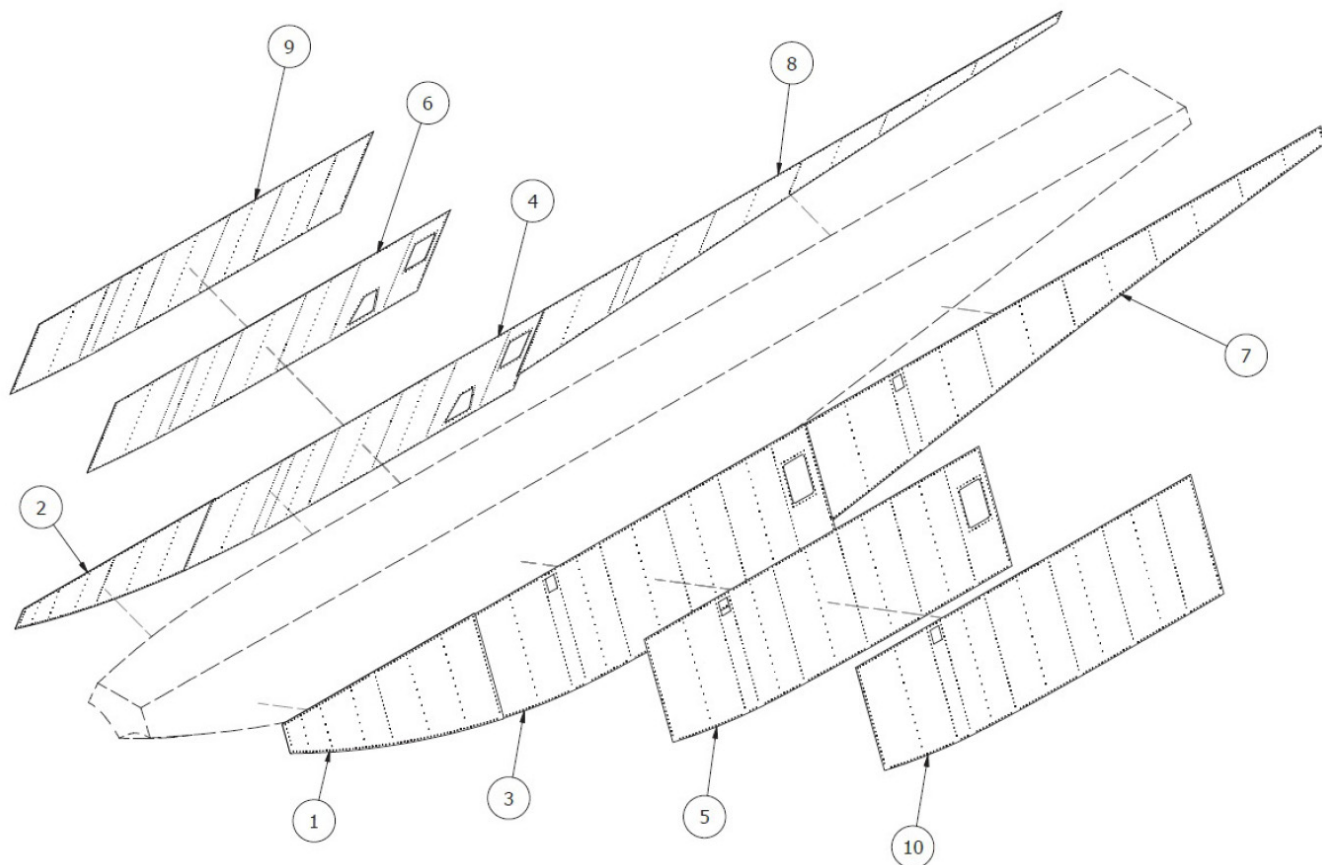

ITEM	QTY	PART NO.	PART DESCRIPTION
1	1	1011180	SKIN, SIDE, FWD, LH
2	1	1011181	SKIN, SIDE, FWD, RH
3	1	1011182	SKIN, SIDE, MID, INBRD, RH
4	1	1011185	SKIN, SIDE, MID, OUTBRD, RH
5	1	1011186	SKIN, SIDE, MID, INBRD, RH
6	1	1011189	SKIN, SIDE, MID, OUTBRD, RH
7	1	1011190	SKIN, SIDE, AFT, INBRD, RH
8	1	1011193	SKIN, SIDE, AFT, OUTBRD, RH
9	1	1011331	SKIN, SIDE, MID, OUTBRD, RH
10	1	1011332	SKIN, SIDE, MID, INBRD, RH

## LEFT FLOAT SIDE SKINS

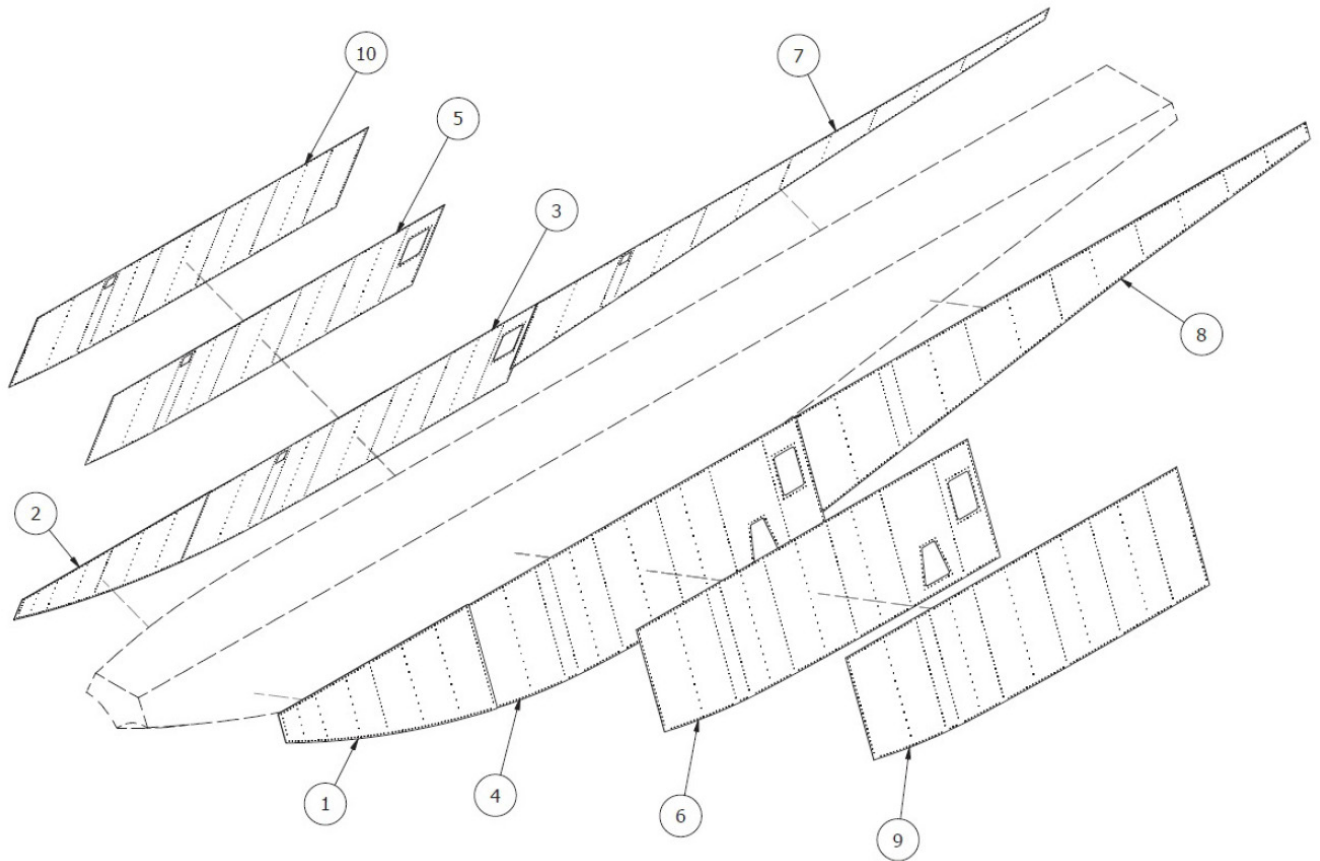

ITEM	QTY	PART NO.	PART DESCRIPTION
1	1	1011180	SKIN, SIDE, FWD, LH
2	1	1011181	SKIN, SIDE, FWD, RH
3	1	1011183	SKIN, SIDE, MID, INBRD, LH
4	1	1011184	SKIN, SIDE, MID, OUTBRD, LH
5	1	1011187	SKIN, SIDE, MID, INBRD, LH
6	1	1011188	SKIN, SIDE, MID, OUTBRD, LH
7	1	1011191	SKIN, SIDE, AFT, INBRD, LH
8	1	1011192	SKIN, SIDE, AFT, OUTBRD, LH
9	1	1011330	SKIN, SIDE, MID, OUTBRD, LH
10	1	1011333	SKIN, SIDE, MID, INBRD, LH

THIS PAGE INTENTIONALLY LEFT BLANK



## SECTION 4 TOP DECK ASSEMBLY

### CONTENTS

TOP DECK - AMPHIBIAN .....	46
TOP DECK - SEAPLANE.....	49

### TOP DECK - AMPHIBIAN

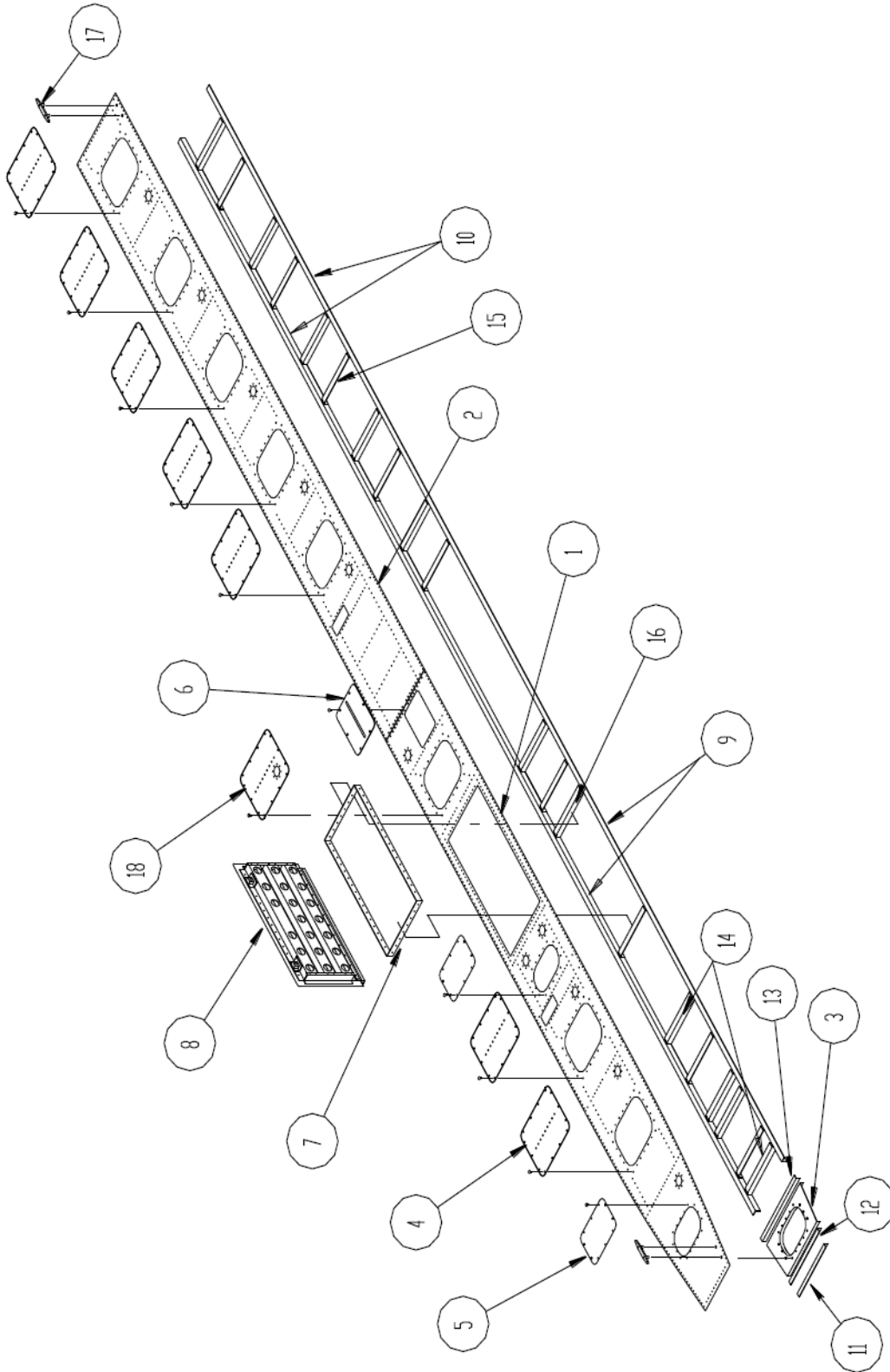

PARTS MANUAL  
3450 FLOATS ON CESSNA 206

ITEM	QTY	PART NO.	PART DESCRIPTION
1	1	34A01148-015	SKIN – FWD SECTION L.
	1	1005565	SKIN – FWD SECTION L. (ALUM. GEAR)
	1	34A01148-016	SKIN – FWD SECTION R.
	1	1005566	SKIN – FWD SECTION R. (ALUM. GEAR)
2	1	34A01148-017	SKIN – AFT SECTION L.
	1	34A01148-018	SKIN – AFT SECTION R.
3	1	21A01002-131	SUPPORT – INSP. COVER – SMALL
	A/R	1002481	NUT – TINNERMAN & INSULATOR
4	7	21A01000-258	INSP. COVER – LARGE - W/ ANGLE & GASKETS
	A/R	SS TATP 8 X 5/8	SCREW – ATTACH
	7	1001437	SEAL – GASKET ONLY
5	2	21A01000-284	INSP. COVER – SMALL & GASKETS
	A/R	SS TATP 8 X 5/8	SCREW – ATTACH
	2	1001728	SEAL – GASKET ONLY
6	1	30A01002-203	COVER – GEAR INDICATOR L.
	1	1005561	COVER – GEAR INDICATOR L. (ALUM. GEAR)
	1	30A01002-202	COVER – GEAR INDICATOR R.
	1	1005560	COVER – GEAR INDICATOR R. (ALUM. GEAR)
	1	10A3-6338-1	PLACARD – DOWN - LAND
	1	10A3-6338-2	PLACARD – UP - WATER
	2	2600-3	SCREW – CAM - LOK
	4	1126000-5	SCREW – CAM – LOK
	6	212-12N	RECEPTACLE – CAM – LOK
7	1	30A01162-042	JAMB – BAGGAGE DOOR
	1	1001573	JAMB – BAGGAGE DOOR, HINGE SIDE
8	1	30A01000-324	ASSY – BAGGAGE DOOR
	1	30A01162-041	COVER - SKIN
	1	30A01741-006	HINGE
	1	30A01004-145	STIFFENER – DOOR
	2	30A01004-144	STIFFENER - DOOR
	2	4A01004-049	STIFFENER ENDS
	2	3A01206-001	RETAINER - LOCK
	2	3A01273-004	LOCK PIN
	2	3A01702-004	CATCH – LATCH
	2	3A01525-003	LOCK SPRING
	2	1002663	RING – OPENING
	1	1001499	SEAL – GASKET (NOT SHOWN)
	1	30A01741-007	HINGE
	1	1002186	HINGE PIN 2.04
	18	01692-0410	POP RIVET
	2	SS 10/32 X ½ INCH	SCREW

ITEM	QTY	PART NO.	PART DESCRIPTION
9	1	34A01326-031	TOP RAIL – FWD L.
	1	34A01326-032	TOP RAIL – FWD R.
10	1	34A01326-033	TOP RAIL – AFT L.
	1	34A01326-034	TOP RAIL – AFT R.
11	1	30A01340-175	STIFFENER
12	1	30A01340-176	STIFFENER
13	1	30A01340-177	STIFFENER
14	2	30A01326-032	STIFFENER
15	A/R	30A01326-022	STIFFENER
16	2	30A01326-030	STIFFENER – BAGGAGE DOOR
17	2	30A01213-007	CLEAT – TIE DOWN
	4	AN4-7A	BOLT
	4	NAS1149D0463J	WASHER
	4	MS21083N4	NUT
18	1	30A01000-359	INSP. COVER – LRG. W/ ANGLE, & GASKET LEFT
	1	30A01000-360	INSP. COVER – LRG. W/ ANGLE, & GASKET RT.
	A/R	SS TATP 8 X 5/8	SCREW – ATTACH
	1	1001437	GASKET ONLY

### TOP DECK - SEAPLANE

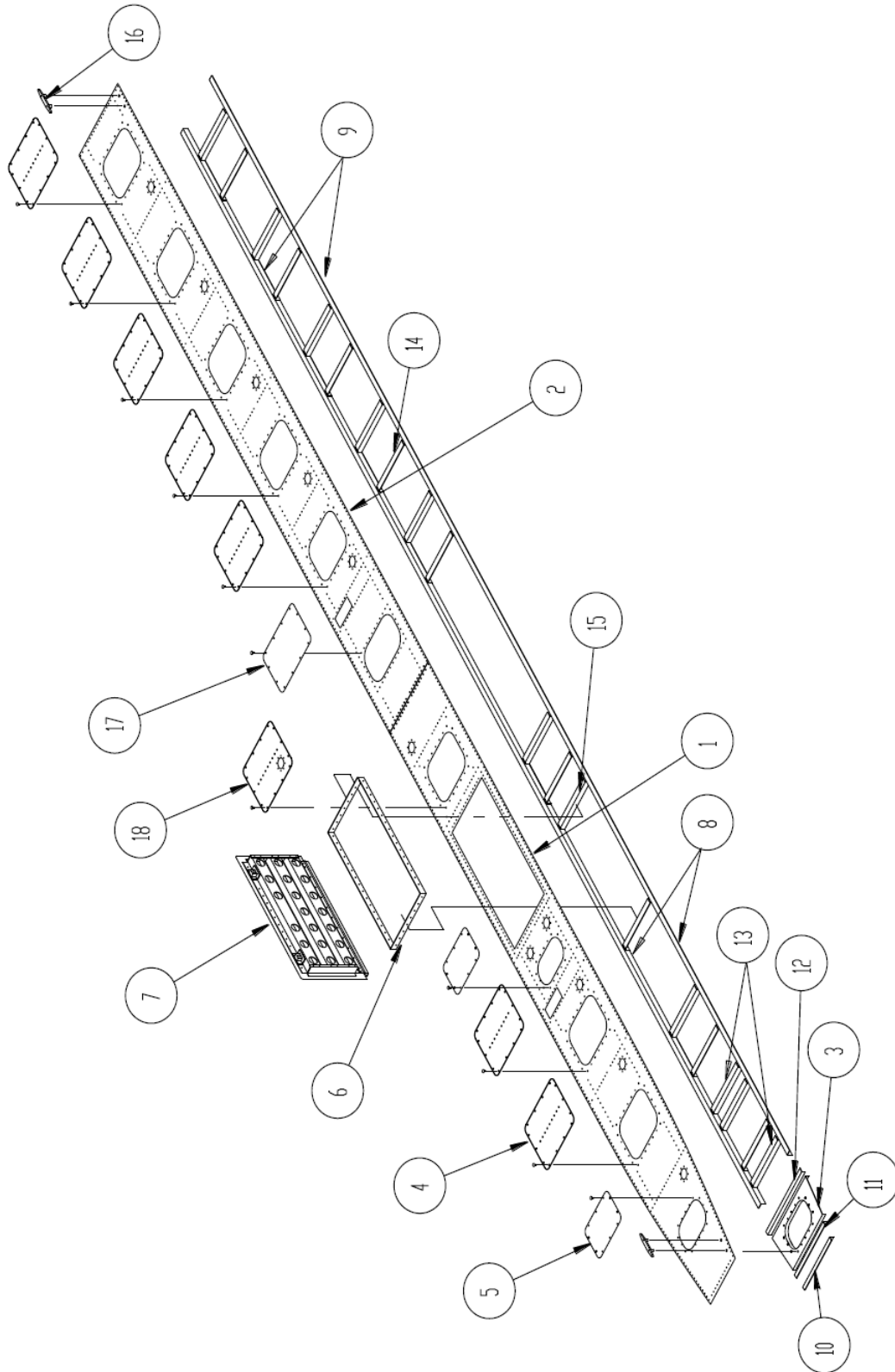

ITEM	QTY	PART NO.	PART DESCRIPTION
1	1	34A01148-015	SKIN – FWD SECTION L.
	1	34A01148-016	SKIN – FWD SECTION R.
2	1	34S01148-043	SKIN – AFT SECTION L.
	1	34S01148-044	SKIN – AFT SECTION R.
3	1	21A01002-131	SUPPORT – INSP. COVER – SMALL
	A/R	1002481	NUT – TINNERMAN & INSULATOR
4	8	21A01000-258	INSP. COVER – LARGE - W/ ANGLE & GASKETS
	A/R	SS TATP 8 X 5/8	SCREW – ATTACH
	8	1001437	SEAL – GASKET ONLY
	1	21A01340-103	STIFFENERS – ANGLE
5	2	21A01000-284	INSP. COVER – SMALL & GASKETS
	A/R	SS TATP 8 X 5/8	SCREW – ATTACH
	2	1001728	SEAL – GASKET ONLY
6	1	30A01162-042	JAMB – BAGGAGE DOOR
	1	1002065	JAMB – BAGGAGE DOOR, HINGE SIDE
7	1	30A01000-324	ASSY – BAGGAGE DOOR
	1	30A01162-041	COVER - SKIN
	1	30A01741-006	HINGE
	1	30A01740-007	HINGE
	1	30A01004-145	STIFFENER – DOOR
	2	30A01004-144	STIFFENER - DOOR
	2	4A01004-049	STIFFENER ENDS
	2	3A01206-001	RETAINER - LOCK
	2	3A01273-004	LOCK PIN
	2	3A01702-004	CATCH – LATCH
	2	3A01525-003	LOCK SPRING
	2	1002663	RING – OPENING
	1	1001499	SEAL – GASKET (NOT SHOWN)
	1	1002186	HINGE PIN 2.04
	18	01692-0410	POP RIVET
8	2	SS 10/32 X ½ INCH	SCREW
	1	34A01326-032	TOP RAIL – FWD R.
9	1	34A01326-033	TOP RAIL – AFT L.
	1	34A01326-034	TOP RAIL – AFT R.
10	1	30A01340-175	STIFFENER
11	1	30A01340-176	STIFFENER
12	1	30A01340-177	STIFFENER
13	2	30A01326-032	STIFFENER
14	A/R	30A01326-022	STIFFENER
15	2	30A01326-030	STIFFENER – BAGGAGE DOOR
16	2	30A01213-007	CLEAT – TIE DOWN

PARTS MANUAL  
3450 FLOATS ON CESSNA 206

ITEM	QTY	PART NO.	PART DESCRIPTION
	4	NAS1149D0463J	WASHER
	4	MS21083N4	NUT
17	1	21S01000-399	INSP. COVER – MED. W/ GASKET
	A/R	SS TATP 8 X 5/8	SCREW ATTACH
	1	21S01567-013	GASKET ONLY
18	1	30A01000-360	INSP. COVER – LRG. W/ ANGLE & GASKET LEFT
	1	30A01000-359	INSP. COVER – LRG. W/ ANGLE & GASKET RIGHT
	A/R	SS TATP 8 X 5/8	SCREW ATTACH
	1	1001437	GASKET

THIS PAGE INTENTIONALLY LEFT BLANK



## SECTION 5 EXTRUSIONS

### CONTENTS

HULL EXTRUSIONS - AMPHIBIAN .....	54
HULL EXTRUSIONS - SEAPLANE.....	56

### HULL EXTRUSIONS - AMPHIBIAN

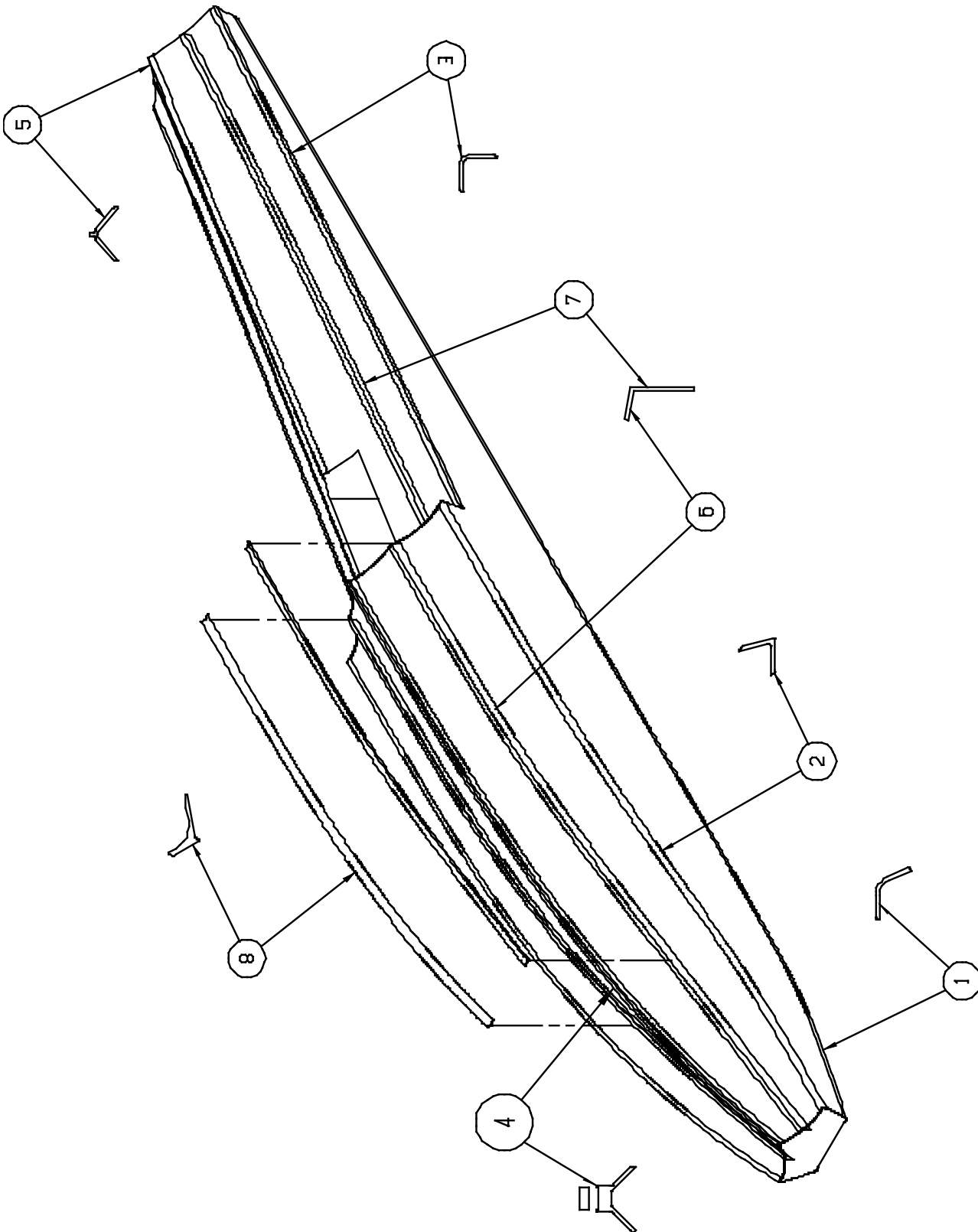

PARTS MANUAL  
3450 FLOATS ON CESSNA 206

ITEM	QTY	PART NO.	PART DESCRIPTION
1	1	34A01324-007	GUNWALL – L. INBOARD
	1	34A01324-008	GUNWALL – R. INBOARD
	1	34A01324-009	GUNWALL – L. OUTBOARD
	1	34A01324-010	GUNWALL – R. OUTBOARD
2	1	34A01394-145	CHINE - FWD L.
	1	34A01394-146	CHINE – FWD R.
3	1	34A01395-003	CHINE – AFTERBODY L.
	1	34A01395-004	CHINE – AFTERBODY R.
4	1	34A01377-002	KEEL - MAIN
	1	3A01200-001	STRIP, WEAR
5	1	34A01425-002	KEEL - AFTERBODY
6	1	34A01361-041	SISTER KEEL – FWD L.
	1	34A01361-042	SISTER KEEL – FWD R.
7	1	34A01361-043	SISTER KEEL – AFT L.
	1	34A01361-044	SISTER KEEL – AFT R.
8	1	34A01342-011	SISTER KEEL – OUTER L.
	1	34A01342-012	SISTER KEEL – OUTER R.

### HULL EXTRUSIONS - SEAPLANE

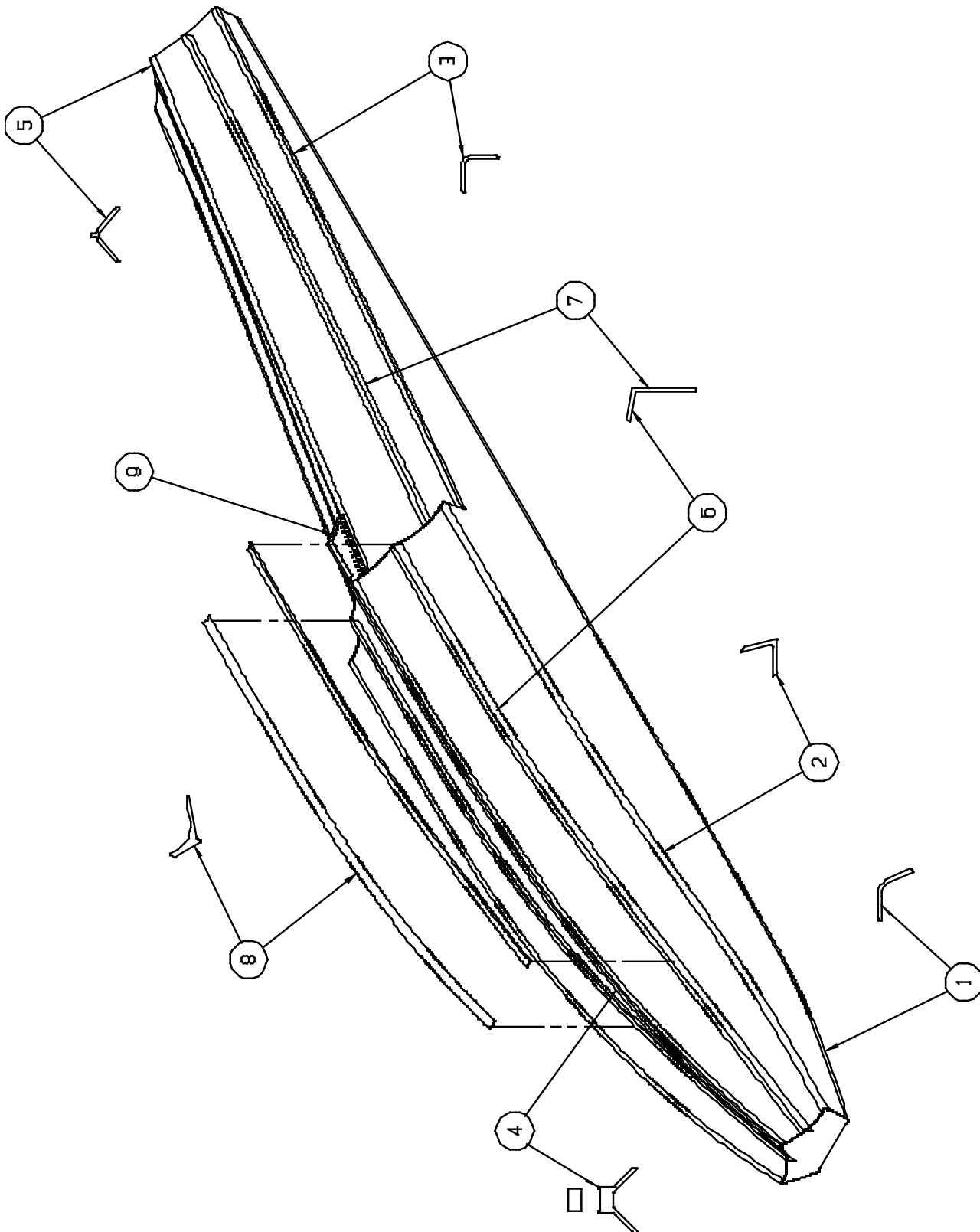

PARTS MANUAL  
3450 FLOATS ON CESSNA 206

ITEM	QTY	PART NO.	PART DESCRIPTION
1	1	34A01324-007	GUNWALL – L. INBOARD
	1	34A01324-008	GUNWALL – R. INBOARD
	1	34A01324-009	GUNWALL – L. OUTBOARD
	1	34A01324-010	GUNWALL – R. OUTBOARD
2	1	34A01394-145	CHINE - FWD L.
	1	34A01394-146	CHINE – FWD R.
3	1	34A01395-003	CHINE – AFTERBODY L.
	1	34A01395-004	CHINE – AFTERBODY R.
4	1	34A01377-002	KEEL - MAIN
	1	3A01200-001	STRIP, WEAR
5	1	34S01425-002	KEEL - AFTERBODY
6	1	34A01361-041	SISTER KEEL – FWD L.
	1	34A01361-042	SISTER KEEL – FWD R.
7	1	34S01361-045	SISTER KEEL – AFT L.
	1	34S01361-046	SISTER KEEL – AFT R.
8	1	34A01342-011	SISTER KEEL – OUTER L.
	1	34A01342-012	SISTER KEEL – OUTER R.
9	1	30S01163-085	ANGLE SUPPORT – AFTERBODY L.
	1	30S01163-086	ANGLE SUPPORT – AFTERBODY R.

THIS PAGE INTENTIONALLY LEFT BLANK

## SECTION 6 PUMPER TUBE INSTALLATION

### CONTENTS

PUMPER TUBE.....	60
------------------	----

## PUMPER TUBE

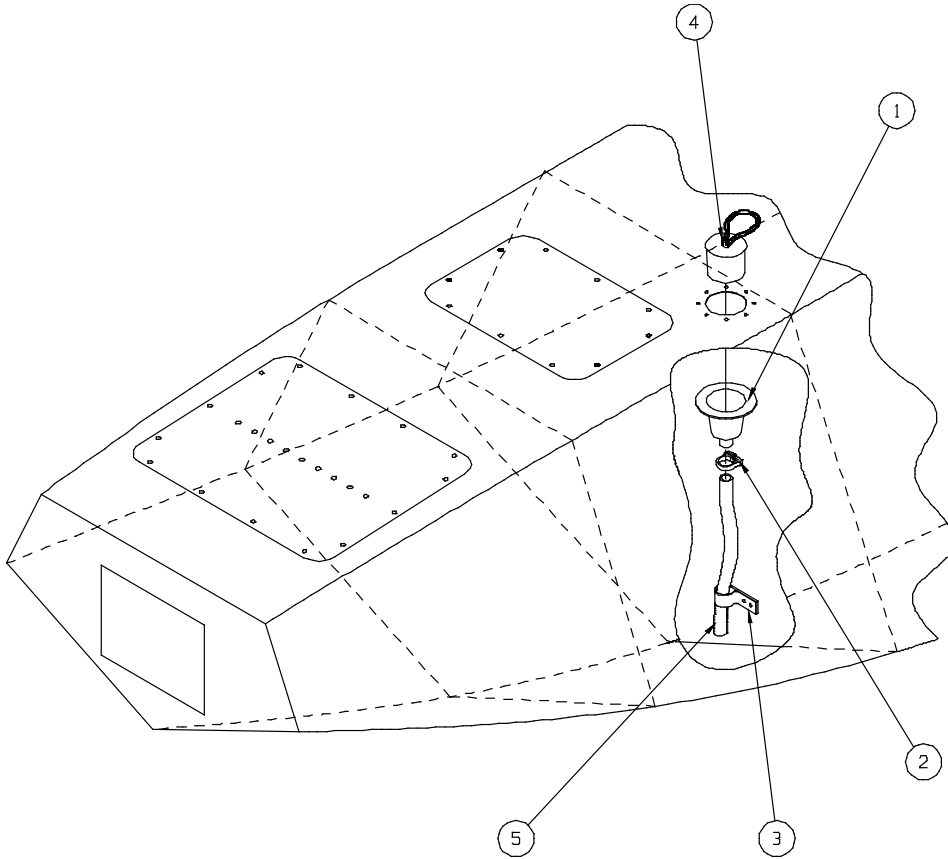

ITEM	QTY	PART NO.	PART DESCRIPTION
1	11	4A01749-001	CUP – PUMPOUT ALUM.
	A/R	AN470AD4-4	RIVETS
2	11	57134	CLAMP – UPPER END
3	1	3A01158-003	CLAMP – LOWER END
4	11	2111	STOPPER – PUMPER TUBE
5	1	30A01618-064	PUMPOUT TUBE 18.5 IN.
	1	30A01618-065	PUMPOUT TUBE 24.5
	1	30A01618-066	PUMPOUT TUBE 26.5
	1	30A01618-067	PUMPOUT TUBE 29.0
	1	30A01618-068	PUMPOUT TUBE 23.0
	1	30A01618-069	PUMPOUT TUBE 26.5
	1	30A01618-070	PUMPOUT TUBE 22.0
	1	30A01618-071	PUMPOUT TUBE 18.0
	1	30A01618-072	PUMPOUT TUBE 15.5
	1	30A01618-073	PUMPOUT TUBE 12.5
	1	30A01618-074	PUMPOUT TUBE 25.0



## SECTION 7 WATER RUDDER, STEERING, AND RETRACT CABLES

### CONTENTS

WATER RUDDER INSTALLATION .....	62
STEERING CABLES .....	64
RETRACT CABLES .....	65
STEERING & RETRACT SYSTEM INSTALLATION .....	66
RETRACT HANDLE ASSEMBLY .....	68
ELECTRO-HYDRAULIC WATER RUDDER RETRACTION SYSTEM (T206H) .....	70

## WATER RUDDER INSTALLATION

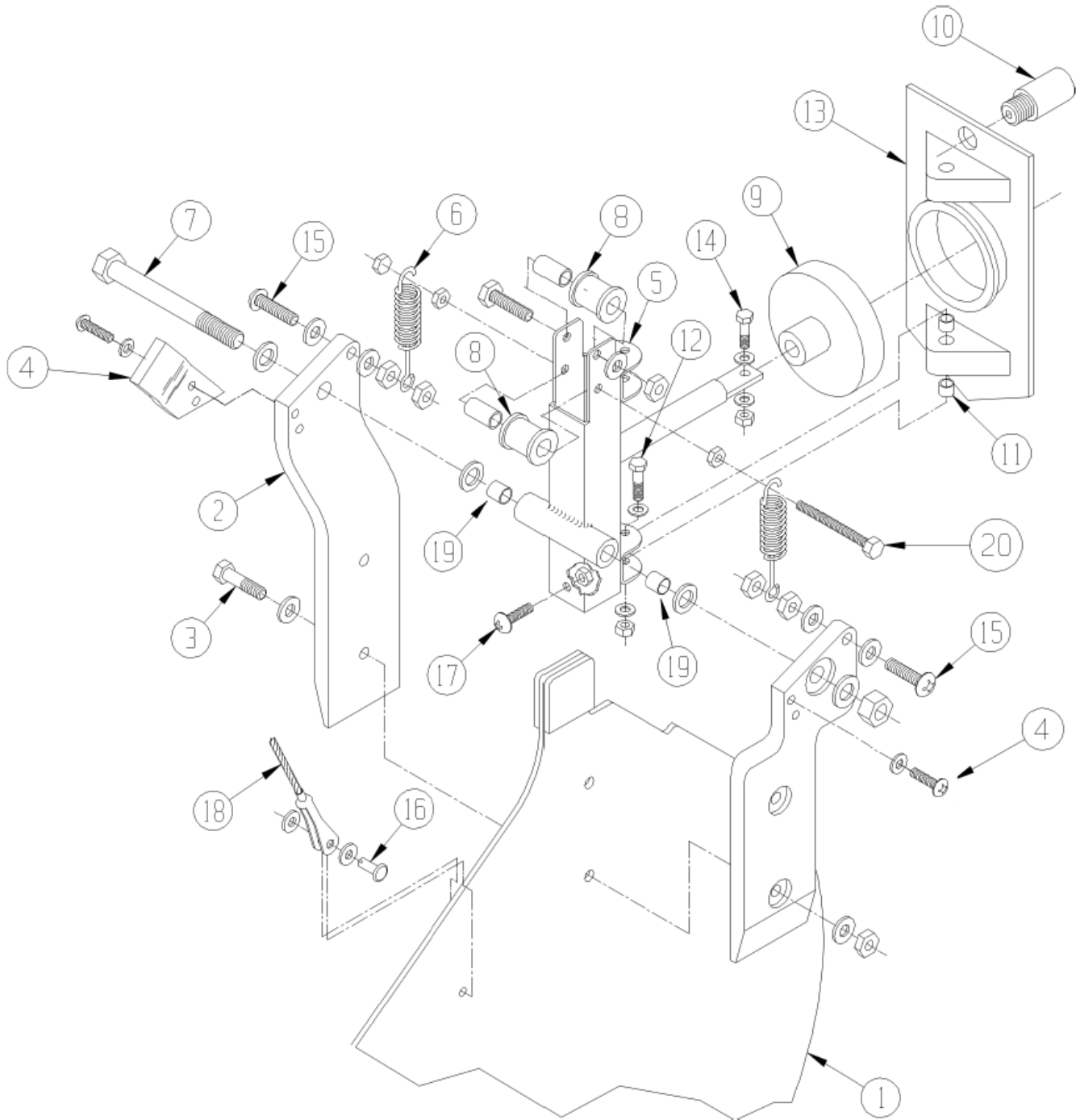

PARTS MANUAL  
3450 FLOATS ON CESSNA 206

ITEM	QTY	PART NO.	PART DESCRIPTION
1	1	4A08000-094	ASS'Y - BLADE
	1	4A08000-062	BLADE
2	1	4A08197-009	ARM - BLADE - L.H.
	1	4A08197-008	ARM - BLADE - R.H.
3	2	AN4-10A	BOLT - ARM ATTACH
	A/R	NAS1149D0463J	WASHER
	2	NAS679A4W	NUT
4	2	4A08205-003	RUDDER STOP - UP
	2	4A08205-004	STOP, WATER RUDDER (SOLOY ONLY)
	4	AN526-1032R10	SCREW
	4	MS35333-39	WASHER - LOCK
5	1	4A08000-097	ASS'Y - WATER RUDDER PIVOT
6	2	3A08525-001	SPRING, RUDDER RETRACT
7	1	AN6C34A	BOLT - WATER RUDDER HINGE
	A/R	NAS1149D0663J	WASHER
	1	MS21083N6	NUT
8	2	3A08606-001	ROLLER - RETRACT CABLE - LOWER
	2	3A08502-001	BUSHING - ROLLER
	2	AN3C10A	BOLT - ROLLER (HEX HD. S.S.)
	6	NAS679A3W	NUT
9	1	3A08650-001	BOOT - WATER RUDDER
10	1	3A08605-001	GUIDE - WATER RUDDER CABLE
11	4	03DU-04	BEARING
12	2	AN3C10A	BOLT - RUDDER POST HINGE
	A/R	NAS1149D0363J	WASHER
	2	NAS679A3W	NUT
13	1	4A01000-301	CASTING - PIVOT - WATER RUDDER
14	1	AN3-6A	BOLT - RUDDER TO ARM ATTACH
	A/R	NAS1149D0363J	WASHER
	1	MS21044N3	NUT
15	2	AN526-428R16	SCREW - SPRING ATTACH
	A/R	NAS1149D0363J	WASHER
	4	NAS679A3W	NUT
16	1	MS20392-2C11	PIN - CLEVIS
	A/R	NAS1149D0316J	WASHER
	1	MS24665-151	COTTER PIN
17	1	AN526-1032R16	SCREW - RUDDER STOP - DOWN
	1	NAS679A3W	NUT
18	1	34A08000-161	ASS'Y - CABLE - RETRACT
19	4	06DU08	BEARING - NYLINER
20	1	1032 X 2" SS	BOLT

## STEERING CABLES

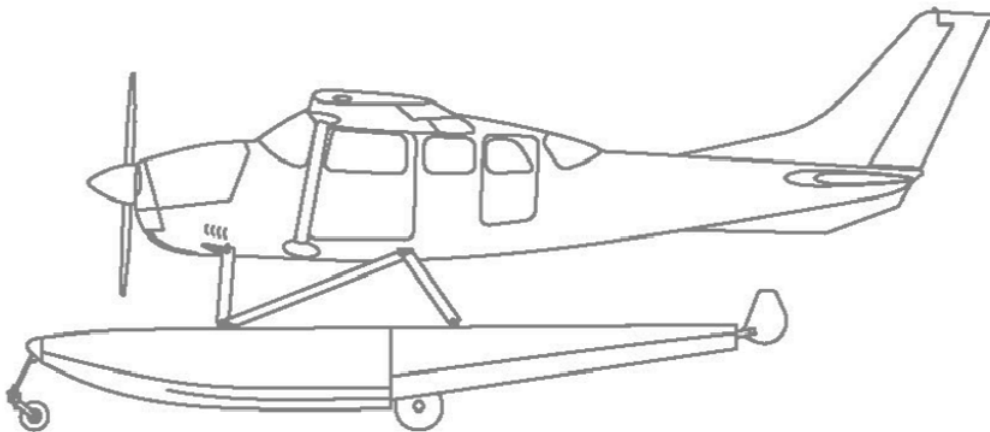
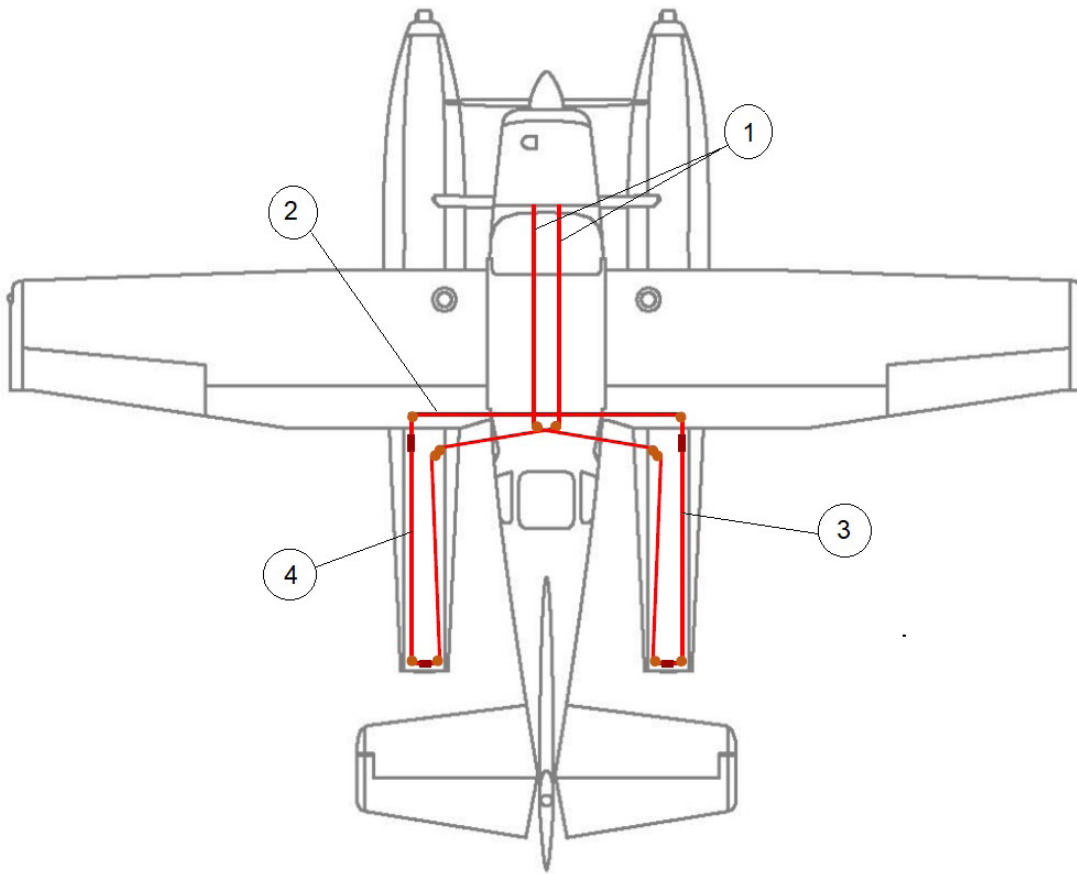

ITEM	QTY	PART NO.	PART DESCRIPTION
1	2	34A08000-160	CABLE ASSY. STEERING
2	1	1003106	ASSEMBLY - CABLE, 80.25 INCHES
3	1	34A08000-158	CABLE ASSY. BALANCE RT.
4	1	34A08000-159	CABLE ASSY. BALANCE LT.

## RETRACT CABLES

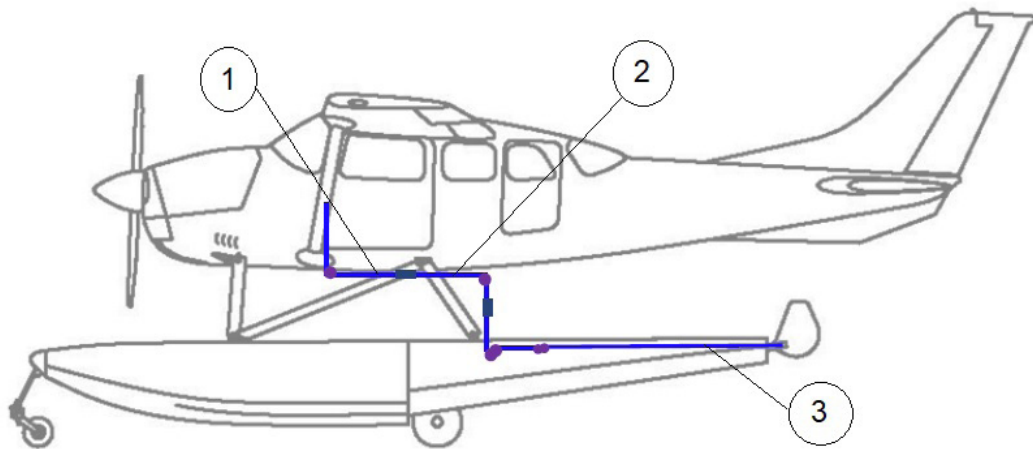
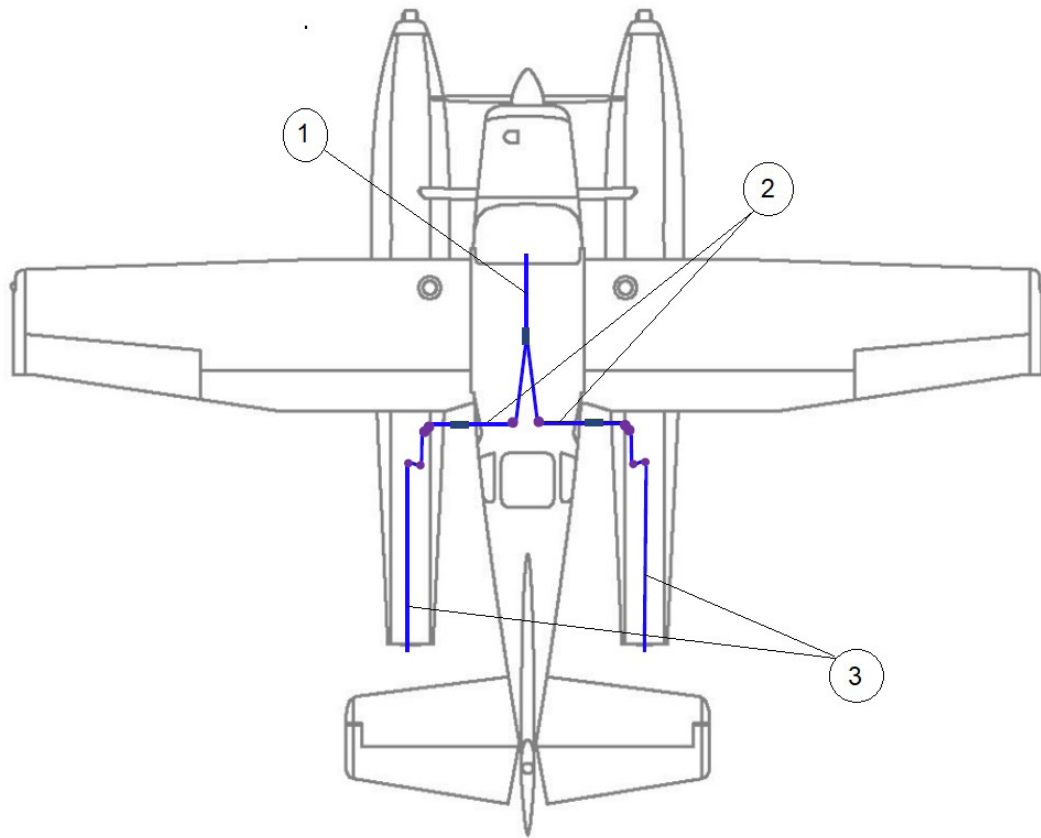

ITEM	QTY	PART NO.	PART DESCRIPTION
1	1	21A08000-137	ASSEMBLY, RETRACT CABLE
2	2	4A08000-075	CABLE ASSY, RETRACT, FUSELAGE
3	2	34A08000-161	CABLE ASSY. RETRACT

# STEERING & RETRACT SYSTEM INSTALLATION

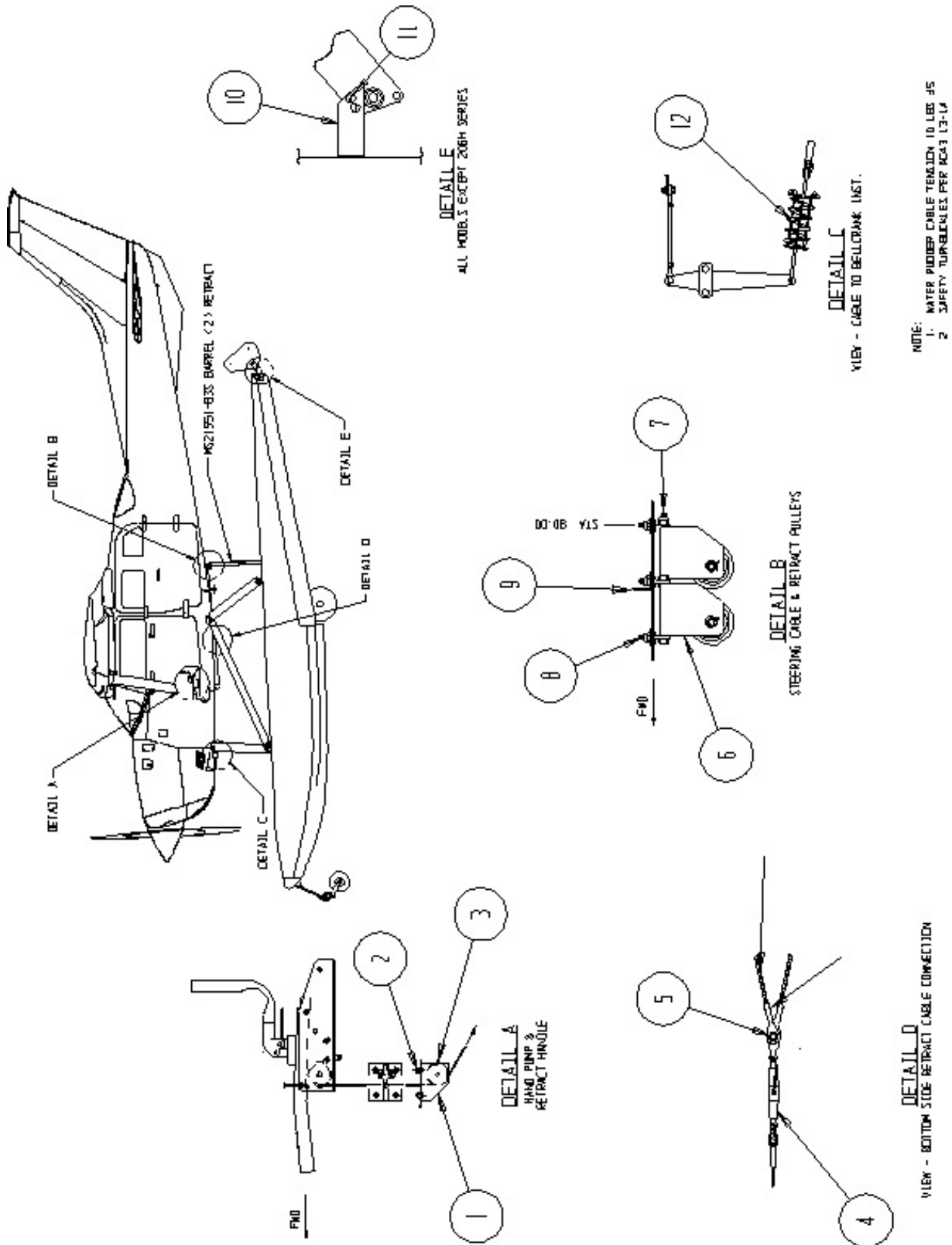

PARTS MANUAL  
3450 FLOATS ON CESSNA 206

ITEM	QTY	PART NO.	PART DESCRIPTION
1	1	3A08151-046	PULLEY BRACKET
2	4	AN526-1032-8	SCREW
	4	MS3533-38	WASHER
	4	MS27130A14	RIVNUT
3	1	MS20219-2	PULLEY
	1	AN4-7A	BOLT
	1	NAS1149D0463J	WASHER
	1	MS21044N4	NUT
4	A/R	MS21251B3S	TURNBUCKLE BARREL
5	1	NAS1149F0332P	WASHER
	1	AN381-2-8	COTTER PIN
	1	MS20392-2-15	CLEVIS PIN
6	4	4A08151-093	PULLEY BRACKET
	4	MS29219-2	PULLEY
	4	AN4-7A	BOLT
	4	NAS1149D0463J	WASHER
	4	MS21044N4	NUT
7	4	AN3-25A	BOLT
	4	NAS1149F0363P	WASHER
	4	MS21044N3	NUT
8	8	AN42B4A	EYE BOLT
	8	NAS1149F0363P	WASHER
	8	MS21044N3	NUT
9	1	4A08340-032	ANGLE
10	2	4A08205-003	STOP (NOT REQUIRED FOR 206H)
	2	4A08205-004	STOP (SOLOY MKI ONLY)
	2	1003822	STOP (SOLOY MKII ONLY)
11	8	AN526-1032-10	SCREW
	8	NAS1149F0332P	WASHER
	8	MS21044N3	NUT
12	2	0742016-1	SPRING (CESSNA)
			<b>ALT. FOR FACTORY SWEDGING OF CABLE ENDS</b>
	A/R	MS21252-3RS	FORKS
	A/R	MS21255-3LS OR -3RS	EYES
	A/R	AN100-3	THIMBLES
	A/R	MS51844-43	NICOPRESS
	A/R	MS20115-3	SHACKLES
	A/R	RM690	CABLES - STAINLESS STEEL AIRCRAFT 3/32 X 7

## RETRACT HANDLE ASSEMBLY

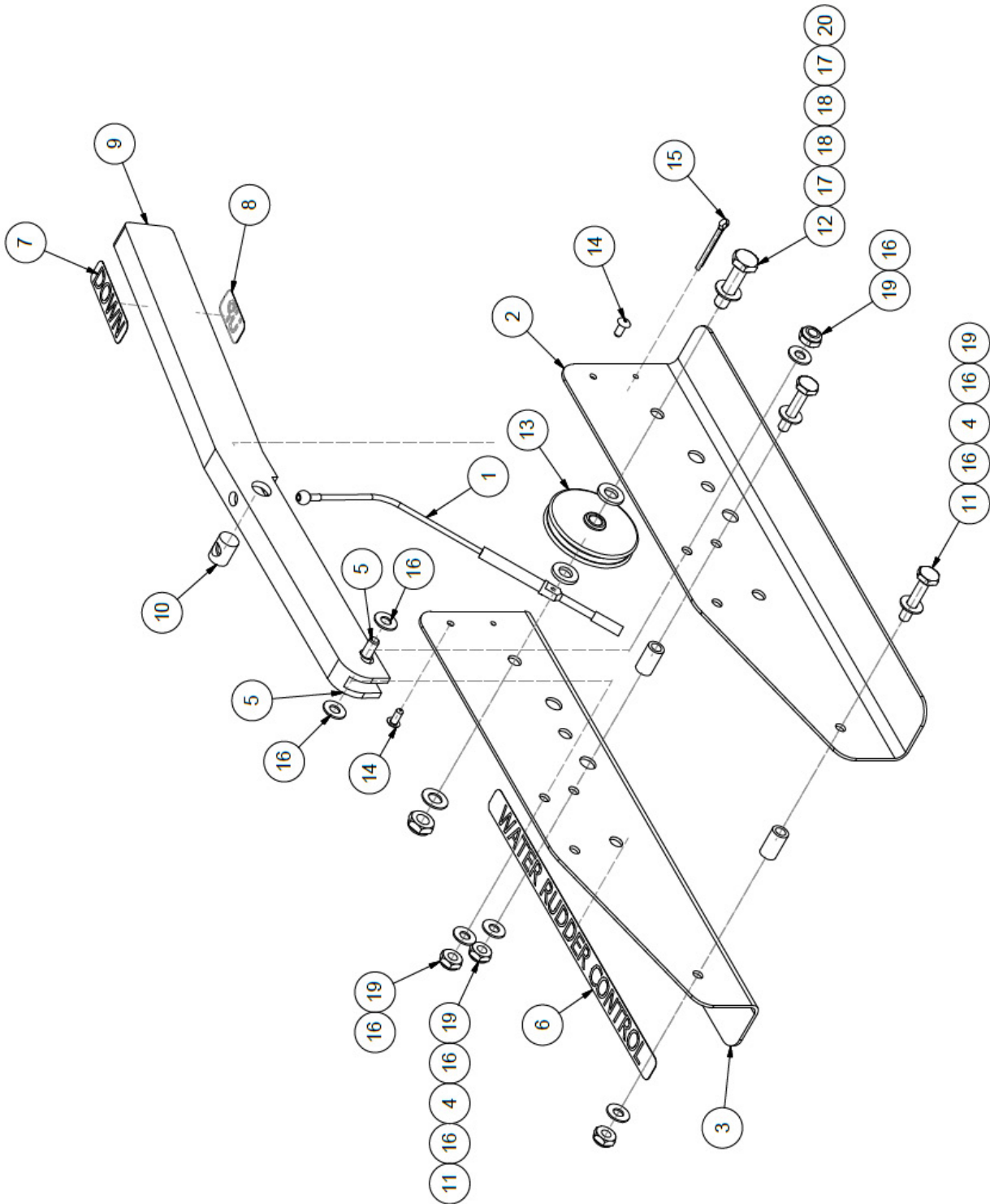



PARTS MANUAL  
3450 FLOATS ON CESSNA 206

ITEM	QTY	PART NO.	PART DESCRIPTION
-	1	23A08000-162	ASSEMBLY, RETRACT HANDLE
1	1	21A08000-137	ASSEMBLY, RETRACT CABLE
2	1	3A08003-015	BRACKET - SIDE, WATER RETRACT, LH
3	1	3A08003-016	BRACKET - SIDE, WATER RETRACT, RH
4	2	3A08613-001	PLASTIC TUBE
5	2	3A08702-006	PIVOT PIN
6	1	3A3-1115-1	PLACARD, WATER RUDDER RETRACT
7	1	3A3-1115-2	PLACARD, WATER RUDDER RETRACT
8	1	3A3-1115-3	PLACARD, WATER RUDDER RETRACT
9	1	4A08414-003	HANDLE, WATER RUDDER RETRACT
10	1	4A08506-002	SWIVEL, RETRACT CABLE HANDLE
11	2	AN3-10A	BOLT
12	1	AN4-10A	BOLT
13	1	MS20219-2	PULLEY
14	2	MS20470AD4	RIVET, UNIVERSAL HEAD
15	1	MS24665-285	COTTER PIN
16	8	NAS1149F0332P	WASHER
17	2	NAS1149F0432P	WASHER
18	2	NAS1149F0463P	WASHER
19	4	NAS679-A3W	KAYNAR NUT
20	1	NAS679-A4W	KAYNAR NUT

# ELECTRO-HYDRAULIC WATER RUDDER RETRACTION SYSTEM (T206H)

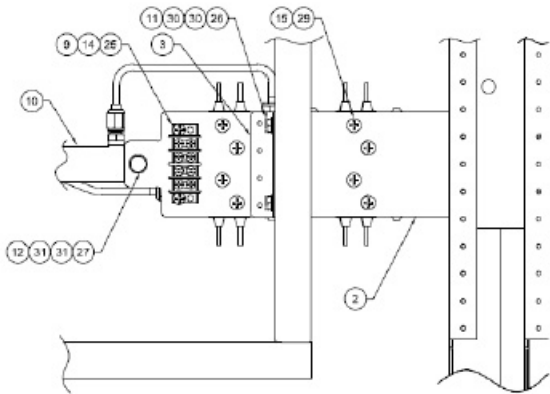

TOP VIEW

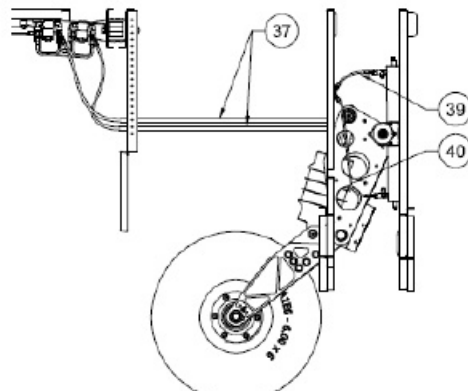
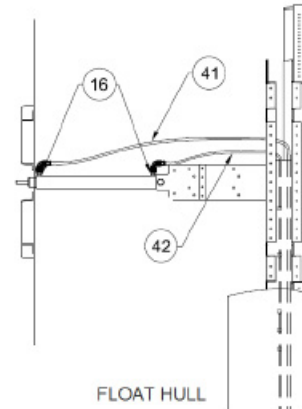

SIDE VIEW

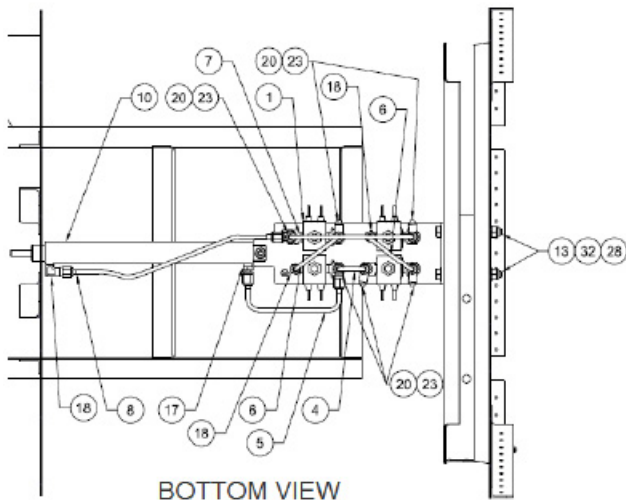

BOTTOM VIEW

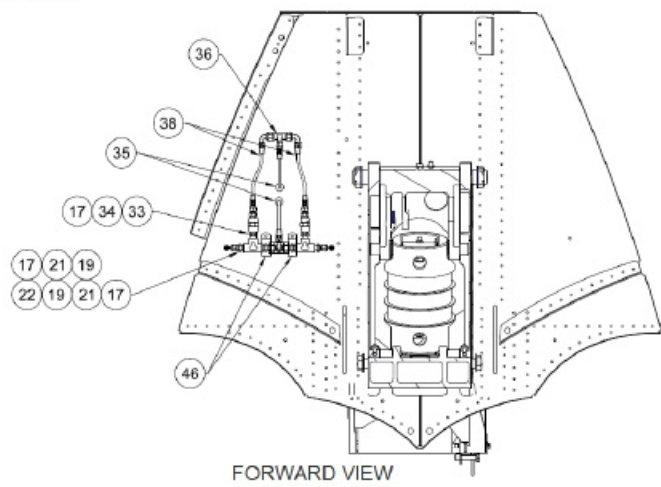

FORWARD VIEW

ITEM	QTY	PART NO.	PART DESCRIPTION
1	4	1006668	SOLENOID, 2 WAY, 2 POSITION
2	2	1006672	MOUNT, CYL, HYD. WATER RUDDER RETRACT
3	2	1006673	SUPPORT, CYL. MOUNT, HYD, WATER RUDDER RETRACT
4	1	1006674	ASSY, HYDRAULIC LINE, SOLENOID TO SOLENOID
5	1	1006675	ASSY, HYDRAULIC LINE SOLENOID TO CYL
6	2	1006676	ASSY, HYDRAULIC LINE, SOLENOID TO SOLENOID
7	1	1006677	ASSY, HYDRAULIC LINE, SOLENOID TO SOLENOID
8	1	1006678	ASSY, HYDRAULIC LINE, SOLENOID TO CYL.
9	1	4-140	4 LUG TERMINAL BLOCK
10	2	7D-7	CLIPPARD CYLINDER
11	2	AN3-3	BOLT
12	2	AN4-7A	BOLT
13	4	AN5-26A	BOLT
14	2	AN526C632R8	SCREW, MACHINE, TRUSS HEAD
15	8	AN526C832R8	SCREW, MACHINE, TRUSS HEAD
16	2	AN816-2D	NIPPLE, FLARED TUBE AND PIPE THREAD
17	1	AN816-3D	NIPPLE, FLARED TUBE AND PIPE THREAD
18	3	AN822-3D	ELBOW
19	2	AN911-1D	NIPPLE
20	6	AN914-1D	ELBOW 90, INTERNAL EXTERNAL
21	2	AN917-1D	TEE, INTERNAL PIPE THREAD
22	1	JSV-2FFF	VALVE, SWIVEL
23	6	MS20826-3D	FITTING TEE
24	2	MS20826-4D	FITTING, TEE
25	2	MS21044N06	NUT
26	2	MS21044N3	NUT
27	2	MS21044N4	NUT
28	4	MS21044N5	NUT
29	8	MS35333-39	STAR WASHER
30	4	NAS1149F0332P	WASHER
31	4	NAS1149F0432P	WASHER
32	8	NAS1149F0563P	WASHER
33	2	46105K61	CHECK VALVE
34	2	AN910-1D	COUPLING, PIPE THREAD
35	2	MS35489-14	GROMMET
36	1	AN824-2D	FITTING, TEE
37	2	1006669-3	ASSEMBLY, HYD. HOSE
38	2	1006669-4	ASSEMBLY, HYD. HOSE
39	1	1006669-5	ASSEMBLY, HYD. HOSE
40	1	1006669-6	ASSEMBLY, HYD. HOSE
41	1	1006669-7	ASSEMBLY, HYD. HOSE

<b>ITEM</b>	<b>QTY</b>	<b>PART NO.</b>	<b>PART DESCRIPTION</b>
42	1	1006669-8	ASSEMBLY, HYD. HOSE
43	1	10066671	PLACARD, WATER RUDDER CONTROL
44	1	29C2739	SWITCH, TOGGLE
45	A/R	22759-16-20-9	WIRE, 20 AWG, WHITE
46	3	MS21919WDG14	CLAMP

## SECTION 8 LANDING GEAR

### CONTENTS

NOSE GEAR RETRACTION ASSEMBLY .....	74
NOSE GEAR LOWER ASSEMBLY .....	76
NOSE WHEEL ASSEMBLY (GROVE) .....	78
NOSE WHEEL ASSEMBLY (PARKER) .....	80
MAIN GEAR INSTALLATION .....	82
MAIN GEAR RETRACTION .....	84
MAIN GEAR HYDRAULIC INSTALLATION .....	86
MAIN GEAR WHEEL ASSEMBLY .....	88
MAIN GEAR SHOCK ASSEMBLY .....	91
MAIN GEAR WITHOUT WHEEL PIVOT ASSEMBLY .....	93
MAIN GEAR WITH WHEEL PIVOT ASSEMBLY .....	95
MAIN GEAR ASSEMBLY .....	97
MAIN GEAR ROTARY ACTUATOR ASSEMBLY .....	99

## NOSE GEAR RETRACTION ASSEMBLY

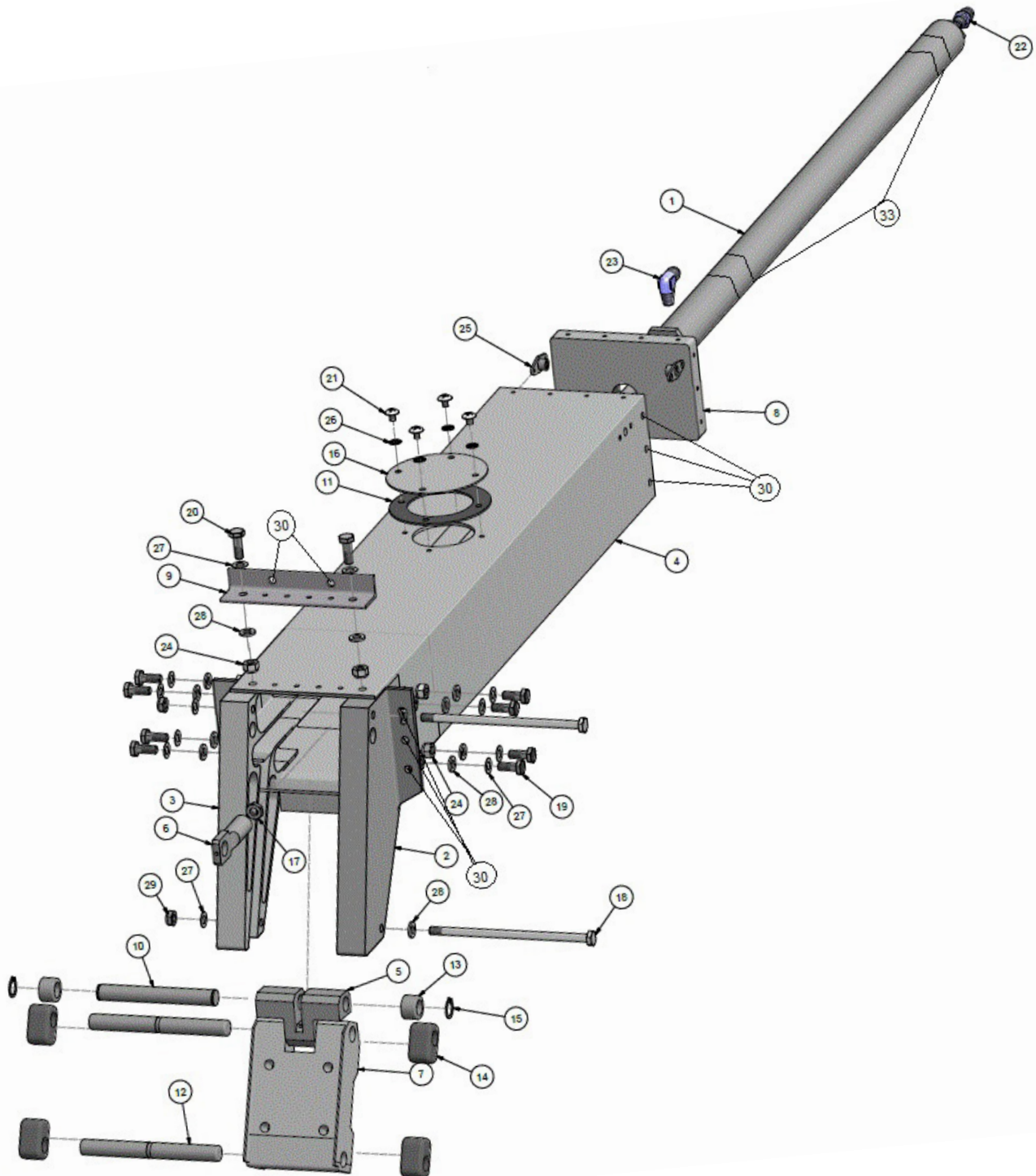

PARTS MANUAL  
3450 FLOATS ON CESSNA 206

ITEM	QTY	PART NO.	PART DESCRIPTION
-	-	30A07000-017	ASSEMBLY, NOSE BOX, 3000/3450
1	1	1002572	CYLINDER, NOSE GEAR, 3000/3450
2	1	1005837	END, NOSE GEAR TRACK LEFT
3	1	1005838	END, NOSE GEAR TRACK, RIGHT
4	1	1005857	NOSE BOX, 3000 FLOAT
5	1	21A07032-005	LINK - TROLLEY, NOSE GEAR
6	1	21A07094-002	END - ROD, CYLINDER, NOSE GEAR
7	1	21A07187-009	TROLLEY - NOSE GEAR
8	1	21A07237-002	END CAP, NOSE BOX
9	1	21A07359-194	EXTRUSION, ANGLE
10	1	21A07509-007	AXLE, TROLLEY LINK
11	1	30A07567-011	GASKET, COVER, NOSE BOX, 2100 AND 3000
12	2	34A07509-008	AXLE, TROLLEY
13	2	3A07530-001	BEARING - TROLLEY, NOSE GEAR
14	4	3A07604-001	BLOCK, SLIDE, TROLLEY, NOSE GEAR
15	2	5100-46-H	SNAP RING
16	1	8A01008-080	COVER, BULKHEAD HYD CYL. HOLE
17	1	AN316-5R	NUT
18	2	AN4-53A	BOLT
19	8	AN4-5A	BOLT
20	2	AN4-6A	BOLT
21	4	AN526-1032R4	SCREW, MACHINE, TRUSS HEAD
22	1	AN816-4D	NIPPLE, FLARED TUBE AND PIPE THREAD
23	1	MS20822-4D	ELBOW
24	10	MS21044N4	NUT
25	2	MS21078-4	NUT PLATE
26	4	MS35333-39	STAR WASHER
27	12	NAS1149D0416J	WASHER
28	12	NAS1149D0463J	WASHER
29	2	NAS679-A4W	KAYNAR NUT
30	10	AN4-5A	BOLT (NOT SHOWN)
	10	NAS1149D0416J	WASHER (NOT SHOWN)
	10	MS21044N4	NUT (NOT SHOWN)
31	1	34A06656-001	NOSE SPRING (NOT SHOWN)
32	1	MS35489-23	GROMMIT (NOT SHOWN)
33	2	3A07005-178	CLIP, SWITCH, NOSE & MAIN

## NOSE GEAR LOWER ASSEMBLY

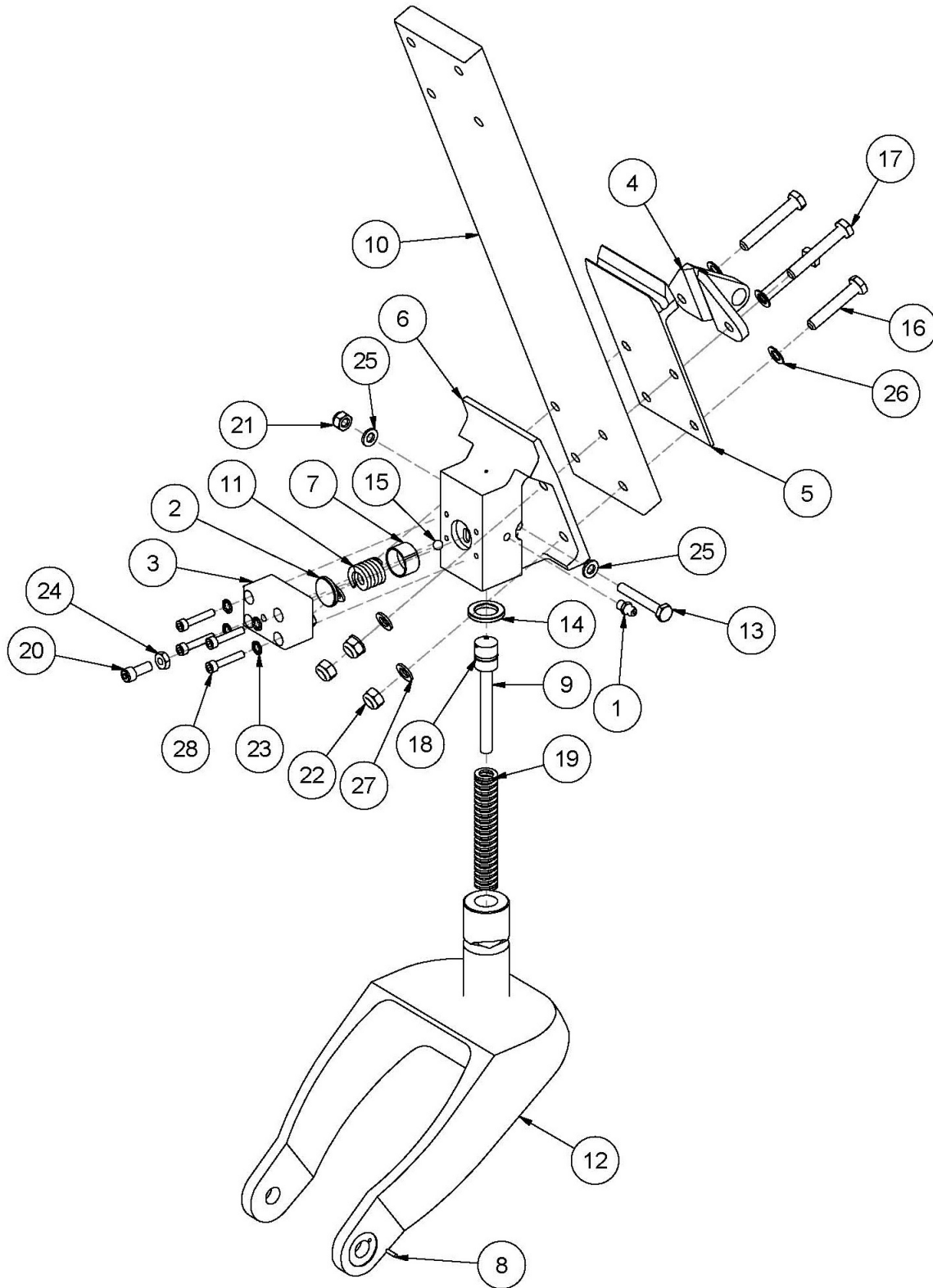



PARTS MANUAL  
3450 FLOATS ON CESSNA 206

ITEM	QTY	PART NO.	PART DESCRIPTION
1	1	1095K41	COMMON GREASEZERK
2	1	21A06160-053	PRESSURE PLATE
3	1	21A06194-005	BLOCK - SPRING
4	1	21A06213-006	TOW HOOK NOSE GEAR
5	1	21A06237-001	BEARING PLATE, LOWER, NOSE GEAR
6	1	21A06318-005	BLOCK - PIVOT, NOSE GEAR
7	1	21A06475-006	FRICITION CUP
8	1	3A06476-001	PIN, ANTIROTATION
9	1	21A06605-002	PLUNGER- NOSE WHEEL, 21, 23, 3, 34
10	1	34A06656-001	SPRING NOSE GEAR
11	1	21A06705-005	PRESSURE SPRING
12	1	30A06000-024	ASSEMBLY, - PIVOT AND FORK, NOSE GEAR
13	1	30A06702-016	BOLT - MODIFIED, PIVOT BLOCK
14	1	3A06602-001	THRUST WASHER
15	1	9528K15	1/4" CHROME BALL BEARING
16	2	AN5-15A	BOLT
17	2	AN5-17A	BOLT
18	1	MS28775-111	O-RING
19	1	M62-350	SPRING
20	1	MS16997-60	BOLT
21	1	MS21044N4	NUT
22	4	MS21044N5	NUT
23	4	MS35333-39	STAR WASHER
24	1	MS35649-2252	NUT
25	2	NAS1149D0463J	WASHER
26	4	NAS1149F0532P	WASHER
27	4	NAS1149F0563P	WASHER
28	4	NAS1352-3-18P	BOLT

## NOSE WHEEL ASSEMBLY (GROVE)

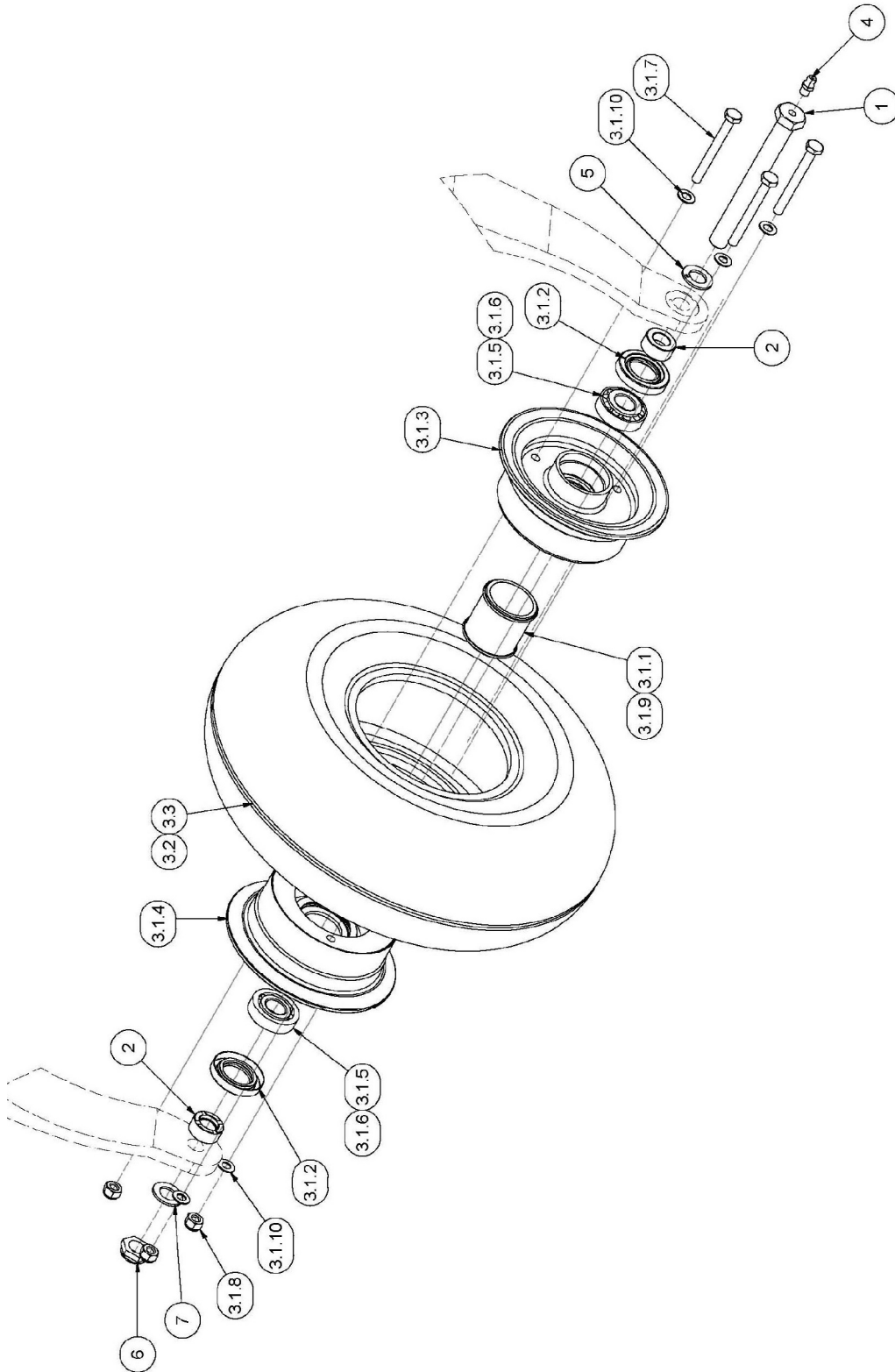

ITEM	QTY	PART NO.	PART DESCRIPTION
1	1	1005927	BOLT, MODIFIED, AXLE, NOSE GEAR
2	2	1005928	SPACER
3	1	1006679	ASSEMBLY, NOSE WHEEL
3.1	1	49-12AF-001	WHEEL ASSEMBLY, GROVE
3.1.1	1	010-019	GREASE RETAINER
3.1.2	2	471570	SEAL, TIMKEN (EQUIVALENT TO GROVE OEM P/N 010-026)
3.1.3	1	015-020A	WHEEL HALF INNER
3.1.4	1	016-020AF	WHEEL HALF OUTER
3.1.5	2	A4050	BEARING CORE
3.1.6	2	A4138	BEARING CONE
3.1.7	3	AN4-23A	BOLT
3.1.8	3	MS21044N-4	NUT
3.1.9	2	MS28775-029	O-RING
3.1.10	6	NAS1149F0416	WASHER
3.2	1	XA1AB*	TUBE
3.3	1	AD1B2*	TIRE
4	1	1095K41	COMMON GREASEZERK
5	1	3A06702-003	MODIFIED WASHER
6	1	MS21083N8	NUT
7	1	NAS1149D0863J	WASHER

\* Any alternate tire (tube type) which is TSO-approved, matches the listed tire's dimensions, and meets its speed/load/ply ratings may be used. Equivalent tubes may also be used.

## NOSE WHEEL ASSEMBLY (PARKER)

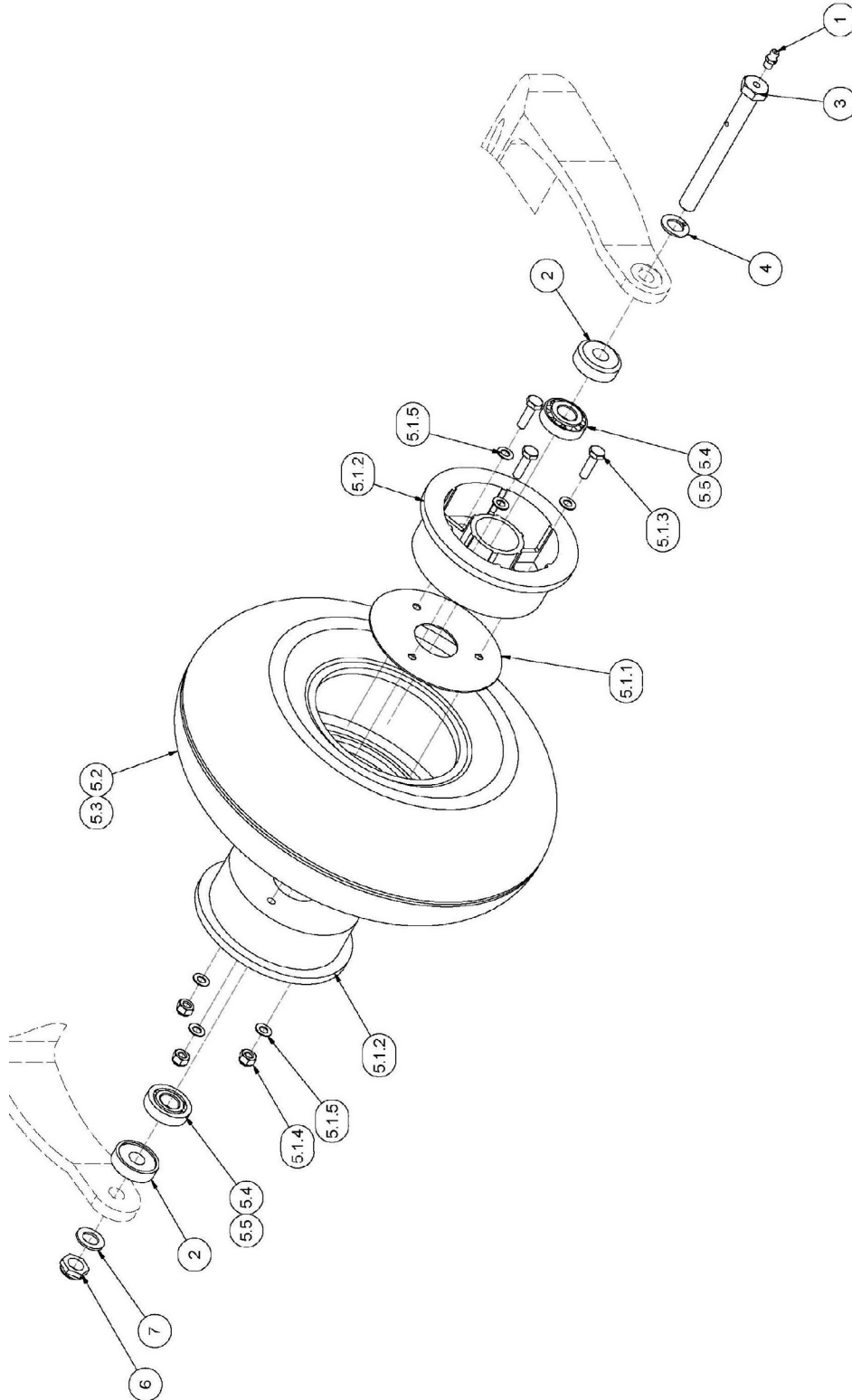

PARTS MANUAL  
3450 FLOATS ON CESSNA 206

ITEM	QTY	PART NO.	PART DESCRIPTION
1	1	1095K41	COMMON GREASEZERK
2	2	3A06259-001	SPACER - NOSE WHEEL - SMALL FLOAT
3	1	3A06702-002	BOLT, MODIFIED, AXLE, NOSE GEAR
4	1	3A06702-003	MODIFIED WASHER
5	1	30A06000-025	NOSE WHEEL ASSEMBLY
5.1	1	D-30380	PARKER WHEEL ASSEMBLY
5.1.1	1	068-30373	GASKET
5.1.2	2	161-30382	WHEEL HALF
5.1.3	3	AN4-7A	BOLT
5.1.4	3	MS21044N4	NUT
5.1.5	6	NAS1149F0432P	WASHER
5.2	1	AD1B2*	TIRE
5.3	1	XA1AB*	TUBE
5.4	2	A4050	BEARING CORE
5.5	2	A4138	BEARING CONE
6	1	MS21083N8	NUT
7	1	NAS1149D0863J	WASHER

\* Any alternate tire (tube type) which is TSO-approved, matches the listed tire's dimensions, and meets its speed/load/ply ratings may be used. Equivalent tubes may also be used.

## MAIN GEAR INSTALLATION

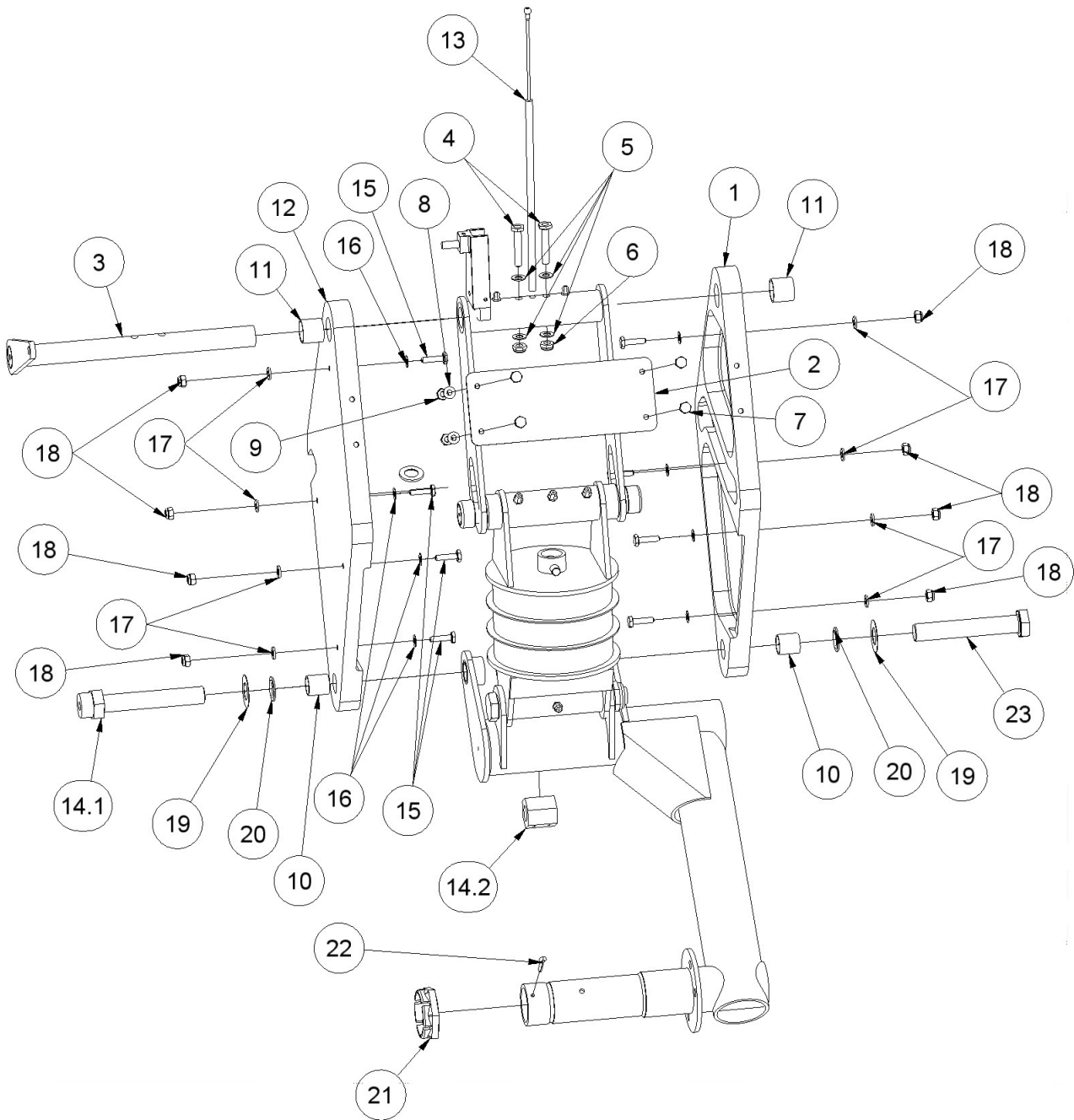

PARTS MANUAL  
3450 FLOATS ON CESSNA 206

ITEM	QTY	PART NO.	PART DESCRIPTION
1	1	30A05114-008	TRACK - MAIN GEAR - RIGHT
2	1	30A05003-085	SPACING PLATE
3	1	30A05000-039	ASS'Y. ARM RETRACT
4	2	NAS6204-17	BOLT
5	4	NAS1149F0432P	WASHER
6	2	MS21083N4	NUT
7	4	AN3-5A	BOLT
8	4	NAS1149D0316J	WASHER
9	4	MS21044N3	NUT
10	2	10DU12	BUSHING
11	2	12DU12	BUSHING
12	1	30A05114-007	TRACK - MAIN GEAR - LEFT
13	1	30A05000-027	ASS'Y - ARM - GEAR INDICATOR
14	1	30A05000-038	MAIN GEAR BOLT ASS'Y - LOWER
14.1	1	30A05558-001	MODIFIED BOLT - DRAG LINK ATTACH (OLD STYLE NON REBUILDABLE HYDRAULIC ACTUATORS)
	1	1005973	MODIFIED BOLT, DRAG LINK ATTACH (NEW STYLE HYDRAULIC ACTUATOR - MUST BE USED PER SERVICE LETTER 97)
14.2	1	30A04574-001	COUPLING - MAIN GEAR
15	8	AN3-6A	BOLT
16	8	NAS1149D0316J	WASHER
17	8	NAS1149D0363J	WASHER
18	8	MS21044N3	NUT
19	2	NAS1149D1016J	WASHER
20	2	93783A033	SEALING WASHER
21	1	MS21025-24	NUT, AXLE
22	1	MS24665-351	COTTER PIN
23	1	30A05702-020	BOLT

## MAIN GEAR RETRACTION

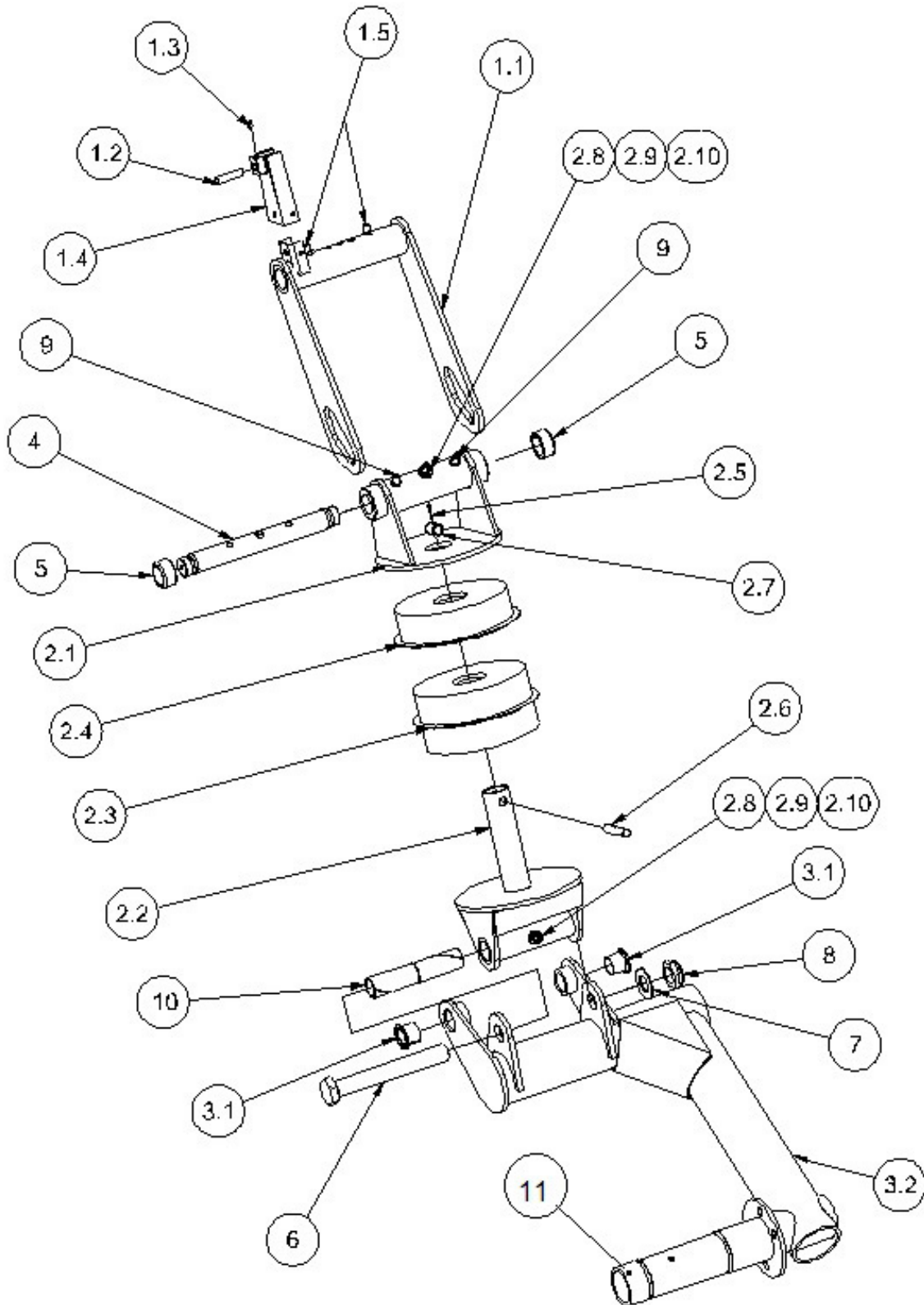



PARTS MANUAL  
3450 FLOATS ON CESSNA 206

ITEM	QTY	PART NO.	PART DESCRIPTION
1	1	30A05000-042	ASS'Y. ARM RETRACT - DRAG LINK
1.1	1	30A05000-041	ASS'Y. ARM RETRACT - DRAG LINK
1.2	1	3A05701-001	CYLINDRICAL MAGNET
1.3	1	1032 NFX 3/16	SET SCREW, 10-32 X 3/16 S.S. CP
1.4	1	30A05214-007	PROX. SWITCH HOLDER
1.5	2	1095K41	COMMON GREASEZERK
	2	NAS1149F0463P	WASHER
2	1	30A04000-100	ASS'Y. SHOCK STRUT
2.1	1	30A04000-093	ASSEMBLY - END SHOCK STRUT - UPPER
2.2	1	30A04000-120	ASSEMBLY - END SHOCK STRUT - LOWER
2.3	1	1002090	DUAL BUSHING ASSEMBLY
2.4	1	1001103	BUSHING ASSEMBLY
2.5	1	MS24665-151	COTTER PIN
2.6	1	30A04476-004	PIN - RETAINING, SHOCK STRUT
2.7	1	30A04459-002	SLEEVE - SHOCK STRUT RETAINER
2.8	2	1095K41	COMMON GREASEZERK
2.9	2	NAS1149D0416J	WASHER
2.10	2	NAS1149D0463J	WASHER
3	1	30A04000-091	DRAG LINK - MAIN GEAR
3.1	2	10FDU10	BUSHING
3.2	1	30A04000-091	ASS'Y. DRAG LINK, MAIN GEAR
4	1	30A04454-007	SHAFT - AXLE - SHOCK STRUT
5	2	21A05520-003	ROLLER, SHOCK STRUT - RETRACT
6	1	30A05702-016	BOLT - DRAG LINK
7	1	NAS1149F1063P	WASHER
8	1	MS21083N10	NUT
9	2	1095K41	COMMON GREASEZERK
10	1	30A04475-006	BUSHING
11	1	6A04263-003	INSERT GREASE WHEEL
	2	MS28775-214	"O" RING
	1	1095K41	COMMON GREASEZERK

## MAIN GEAR HYDRAULIC INSTALLATION

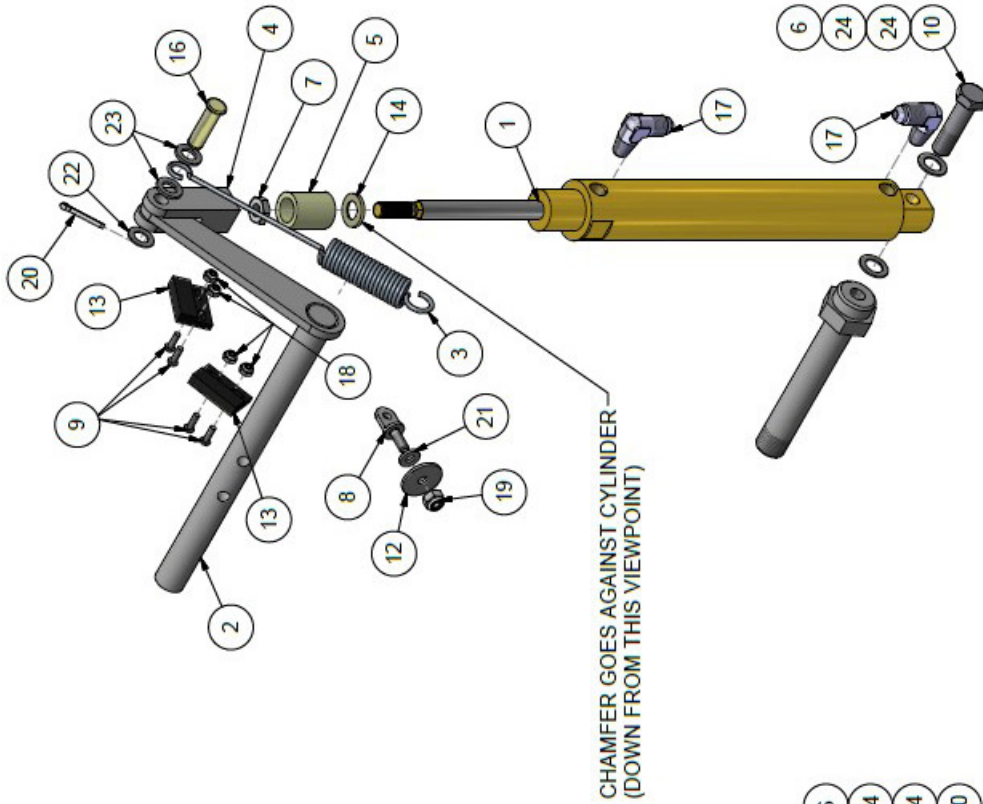

**NEW STYLE CLEVIS**  
(SEE SERVICE LETTER 139)

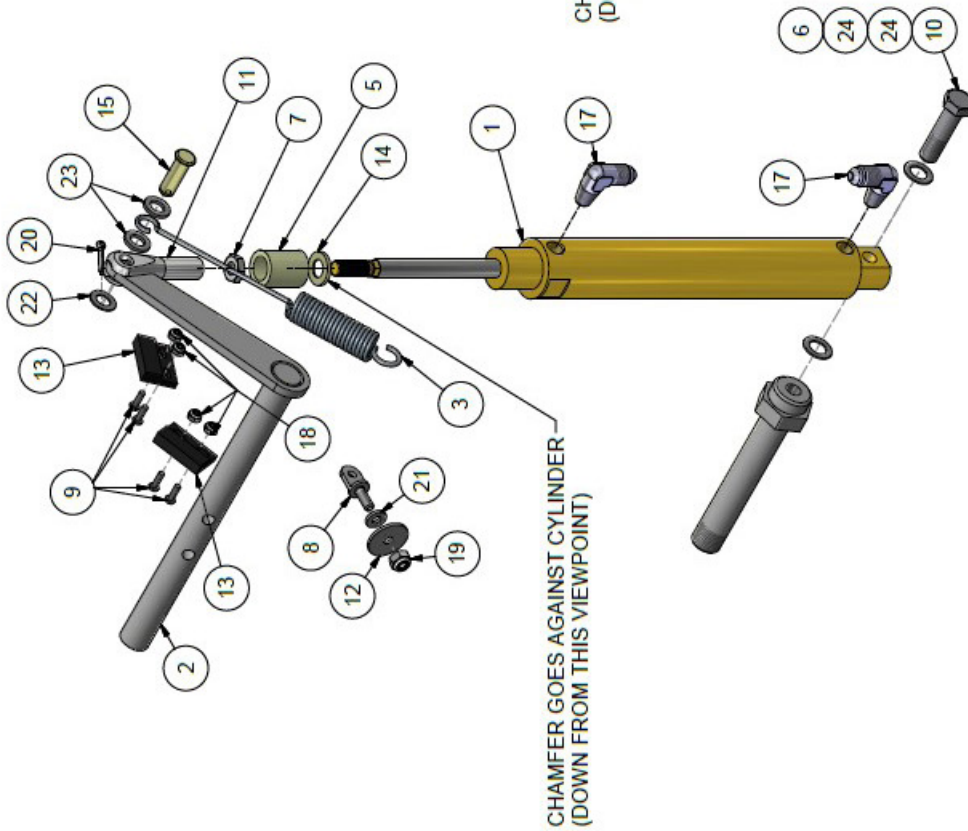

**OLD STYLE CLEVIS**

PARTS MANUAL  
3450 FLOATS ON CESSNA 206

ITEM	QTY	PART NO.	PART DESCRIPTION
1	1	1002573*	CYLINDER-MAIN GEAR, 3000-3450
2	1	21A05000-016	WELDMENT, ARM RETRACT, RIGHT
3	1	21A05525-008	SPRING - GEAR
4	1	30A05252-001	SPACER - HYDRAULIC CYLINDER
5	1	30A05460-001	CLEVIS - RETRACT ARM, MAIN GEAR, (3000/3450)
6	1	30A05558-001	MODIFIED BOLT - DRAG LINK ATTACH (OLD STYLE NON REBUILDABLE HYDRAULIC ACTUATORS)
	1	1005973	MODIFIED BOLT, DRAG LINK ATTACH (NEW STYLE HYDRAULIC ACTUATOR - MUST BE USED PER SERVICE LETTER 97)
7	1	AN316-5R	NUT
8	1	AN42-4A	EYE BOLT
9	4	AN515-4R6	SCREW, MACHINE
10	1	AN6-13A	BOLT
11	1	AN665-46RS	TERMINAL, FLY WIRE
12	1	AN970-3	WASHER
13	2	HAMLIN 59135-20	HAMLIN MAGNETIC SWITCH
14	1	MS20002C6	WASHER - COUNTER SUNK
15	1	MS20392-4C25	CLEVIS PIN
16	1	MS20392-4C29	CLEVIS PIN
17	2	MS20822-4-4D	ELBOW
18	4	MS21044N04	NUT
19	1	MS21044N3	NUT
20	2	MS24665-283	COTTER PIN
21	1	NAS1149D0363J	WASHER
22	1	NAS1149F0532P	WASHER
23	2	NAS1149F0563P	WASHER
24	2	NAS1149F0632P	WASHER

\* If this style actuator is replacing the old style non rebuildable cylinder, reference Service Letter 97 for replacement and the correct drag link attach modified bolt.

## MAIN GEAR WHEEL ASSEMBLY

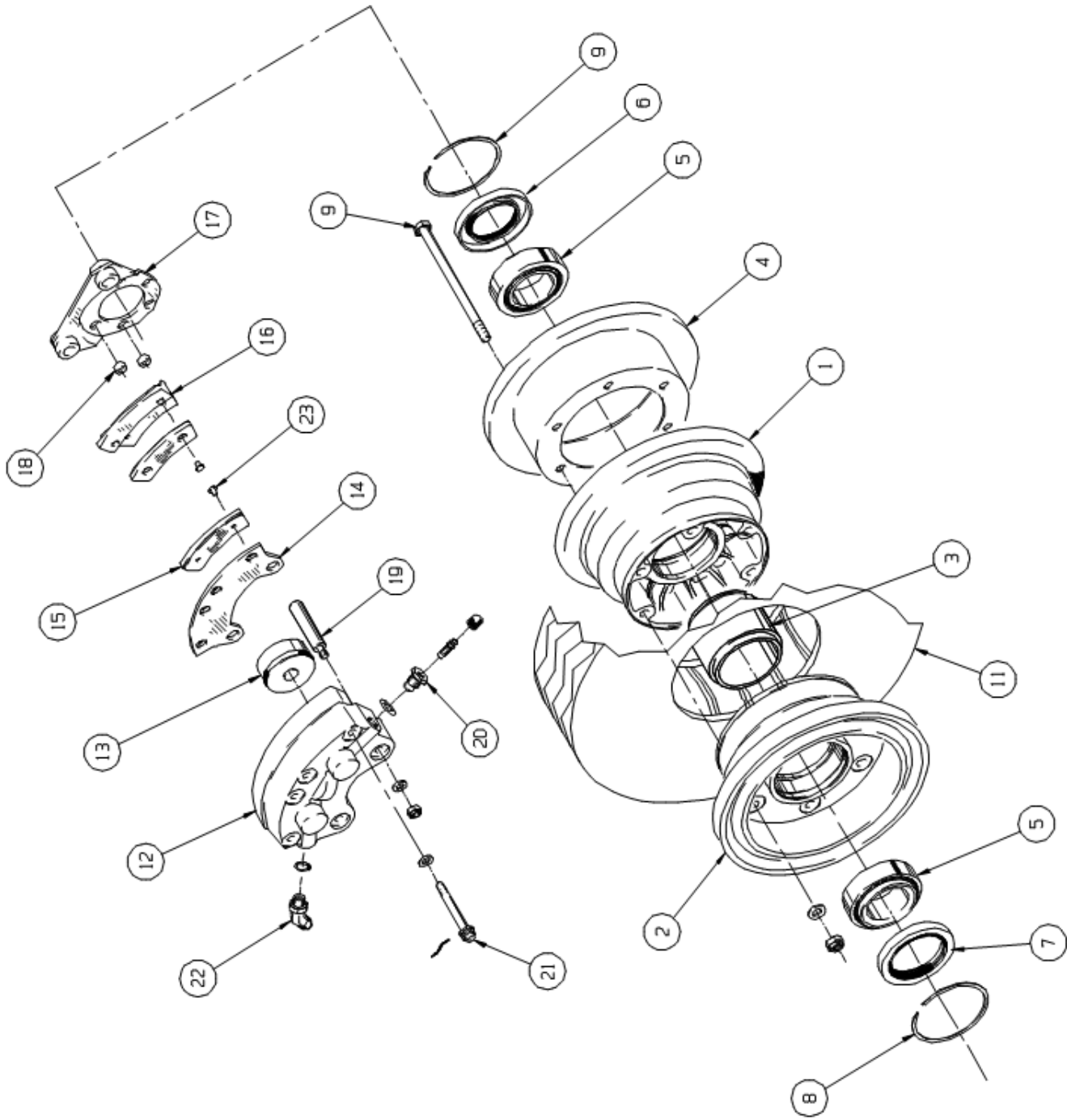

PARTS MANUAL  
3450 FLOATS ON CESSNA 206

ITEM	QTY	PART NO.	PART DESCRIPTION
1	1	8A04000-031	WHEEL ASS'Y. (W/ TIRE & TUBE)
2	1	40-418-3	WHEEL ASS'Y. (BOTH HALVES)
3	1	067-14700	SPACER – GREASE DAM
4	1	164-24501	DISC – BRAKE
5	2	13836	CUP – BEARING
	2	13889	CONE – BEARING
6	1	473232	SEAL – GREASE
7	1	472439	SEAL – GREASE
8	2	155-14300	RING - SNAP
9	6	AN5-35A	BOLT
	6	NAS1149F0563P	WASHER
	6	MS21042-5	NUT
10	1	166-20000	NAMEPLATE – “WARNING” (NOT SHOWN)
	1	166-19700	NAMEPLATE (NOT SHOWN)
11	1	AA1E6*	TIRE
	1	XA1AD*	TUBE
12	1	30A04000-103	ASSEMBLY, BRAKE CALIPER, LH, 3000/3450
	1	30A04000-102	ASSEMBLY, BRAKE CALIPER, RH, 3000/3450
	1	6A04561-001	FILM, BRAKE CALIPER SURFACE PROTECTOR
13	2	062-10700	PISTON
	1	MS28775-222	O-RING
14	1	063-01100	PLATE - PRESSURE
15	2	066-10500	LINING - BRAKE
16	1	064-01500	PLATE – BACK
17	1	075-20700	PLATE - TORQUE
	4	AN5-6A	BOLT (NOT SHOWN)
	8	NAS1149F0532P	WASHER (NOT SHOWN)
	4	MS21044N5	NUT (NOT SHOWN)
18	1	30A04523-002	BUSHING
19	2	069-03100	BOLT - ANCHOR
	2	NAS1149F0463P	WASHER
	2	MS21044N4	NUT
20	1	081-00200	SEAT - BLEEDER
	1	MS28775-012	O-RING
	1	079-00300	SCREW – BLEEDER
	1	183-00100	CAP – BLEEDER
21	4	MS21250H04026	BOLT
	4	MS20002C4	WASHER
	A/R	MS20995-C32	LOCKWIRE
22	1	104-04700	FITTING
	1	MS28775-012	O-RING

ITEM	QTY	PART NO.	PART DESCRIPTION
23	4	105-00200	RIVET

\* Any alternate tire (tube type) which is TSO-approved, matches the listed tire's dimensions, and meets its speed/load/ply ratings may be used. Equivalent tubes may also be used.

## MAIN GEAR SHOCK ASSEMBLY

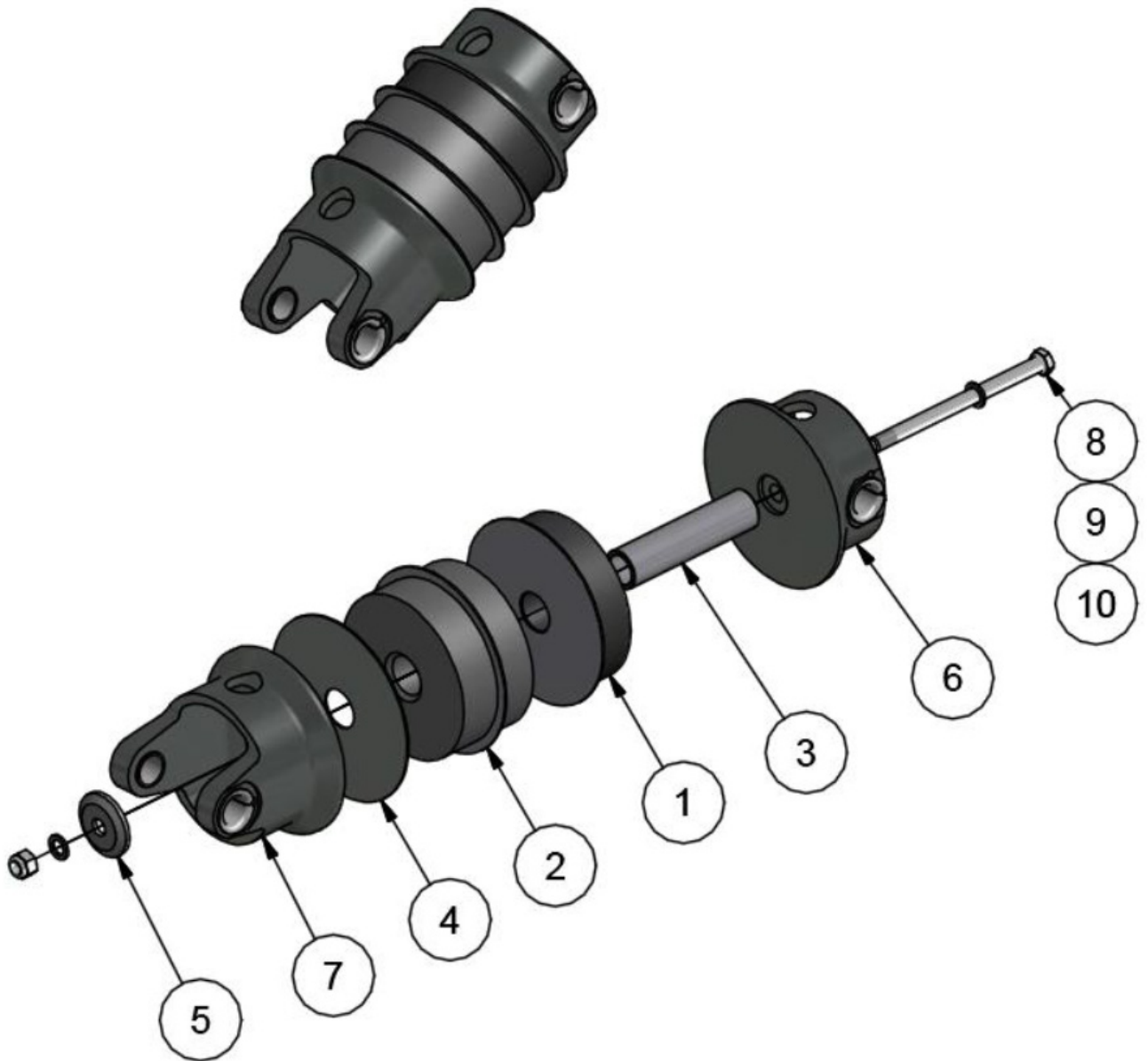

ITEM	QTY	PART NO.	PART DESCRIPTION
-	2	1004286-04	ASS'Y. SHOCK, HEAVY DUTY, MAIN GEAR (185)
1	1	1001103	BUSHING ASS'Y., SHOCK STRUT
2	1	1002090	BUSHING ASS'Y., DUAL, SHOCK STRUT
3	1	1004267	TUBE, STRUT, MAIN
4	1	1004268	SHOCK SPACER, MAIN
5	1	1004269	STRUT END CAP, MAIN
6	1	1005765	ASS'Y., UPPER SHOCK STRUT, MAIN
7	1	1005766	ASS'Y., LOWER SHOCK STRUT, MAIN
8	1	AN6-52A	BOLT
9	1	MS21044N6	NUT
10	1	NAS1149F0663P	WASHER



## MAIN GEAR WITHOUT WHEEL PIVOT ASSEMBLY

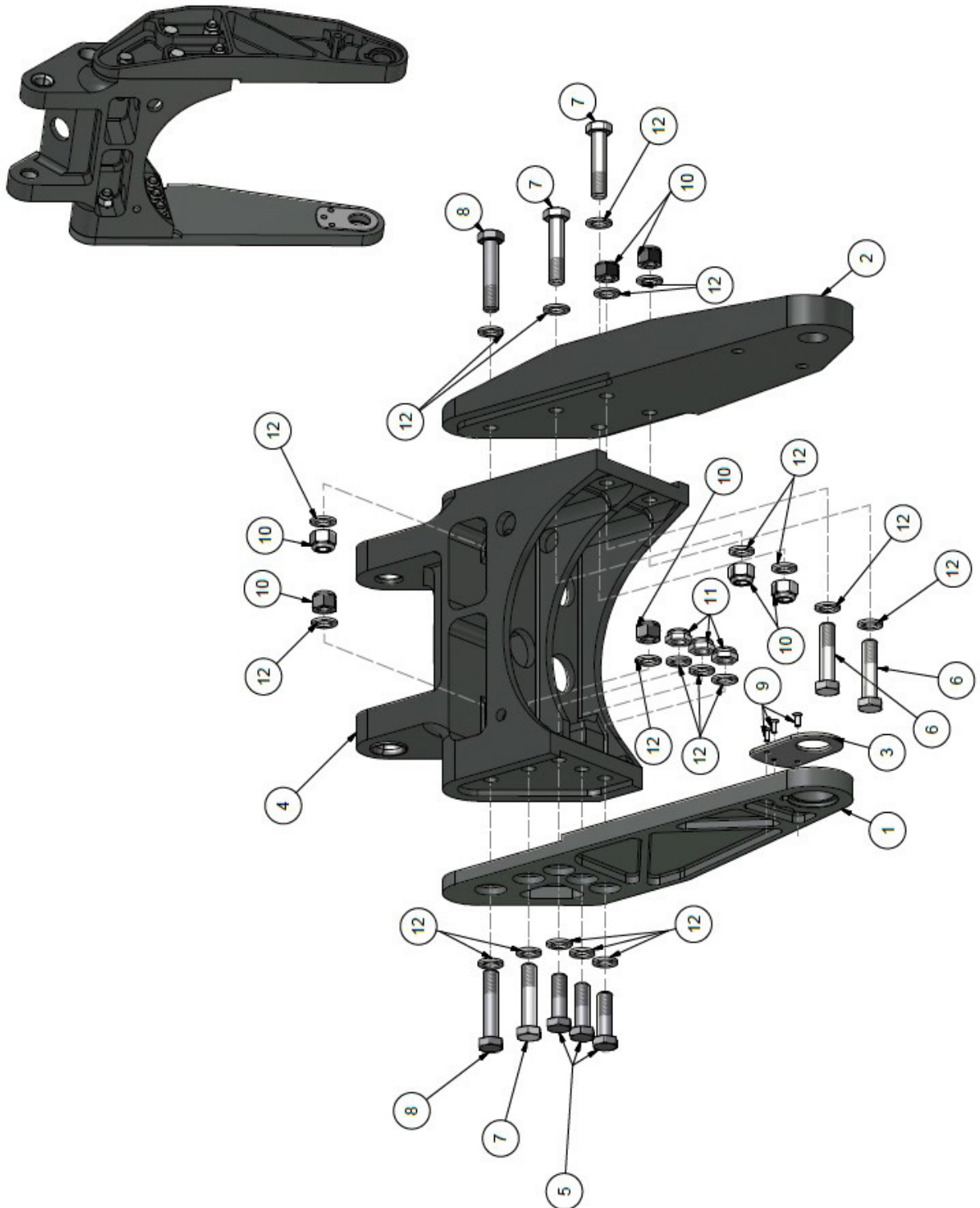

ITEM	QTY	PART NO.	PART DESCRIPTION
-	1	1005746	ASS'Y., PIVOT, RH, MAIN GEAR W/O WHEEL
-	1	1005747	ASS'Y., PIVOT, LH, MAIN GEAR W/O WHEEL
1	1	1004274	LINK ARM, OUTBRD, RT FLOAT
	1	1005370	LINK ARM, OUTBRD, LT FLOAT
2	1	1004275	LINK ARM, INBRD, RT FLOAT
	1	1005369	LINK ARM, INBRD, LT FLOAT
3	1	1005387	GREASE COVER, MAIN GEAR, 3000 3450
4	1	1005744	ASSY, CENTER LINK, RH, MAIN GEAR
	1	1005745	ASSY, CENTER LINK, LH, MAIN GEAR
5	3	AN6-11A	BOLT
6	2	AN6-14A	BOLT
7	3	AN6-15A	BOLT
8	2	AN6-16A	BOLT
9	3	MS20426-4	RIVET-FLAT HEAD
10	7	MS21044N6	NUT
11	3	MS21083N6	NUT
12	20	NAS1149D0663J	WASHER

## MAIN GEAR WITH WHEEL PIVOT ASSEMBLY

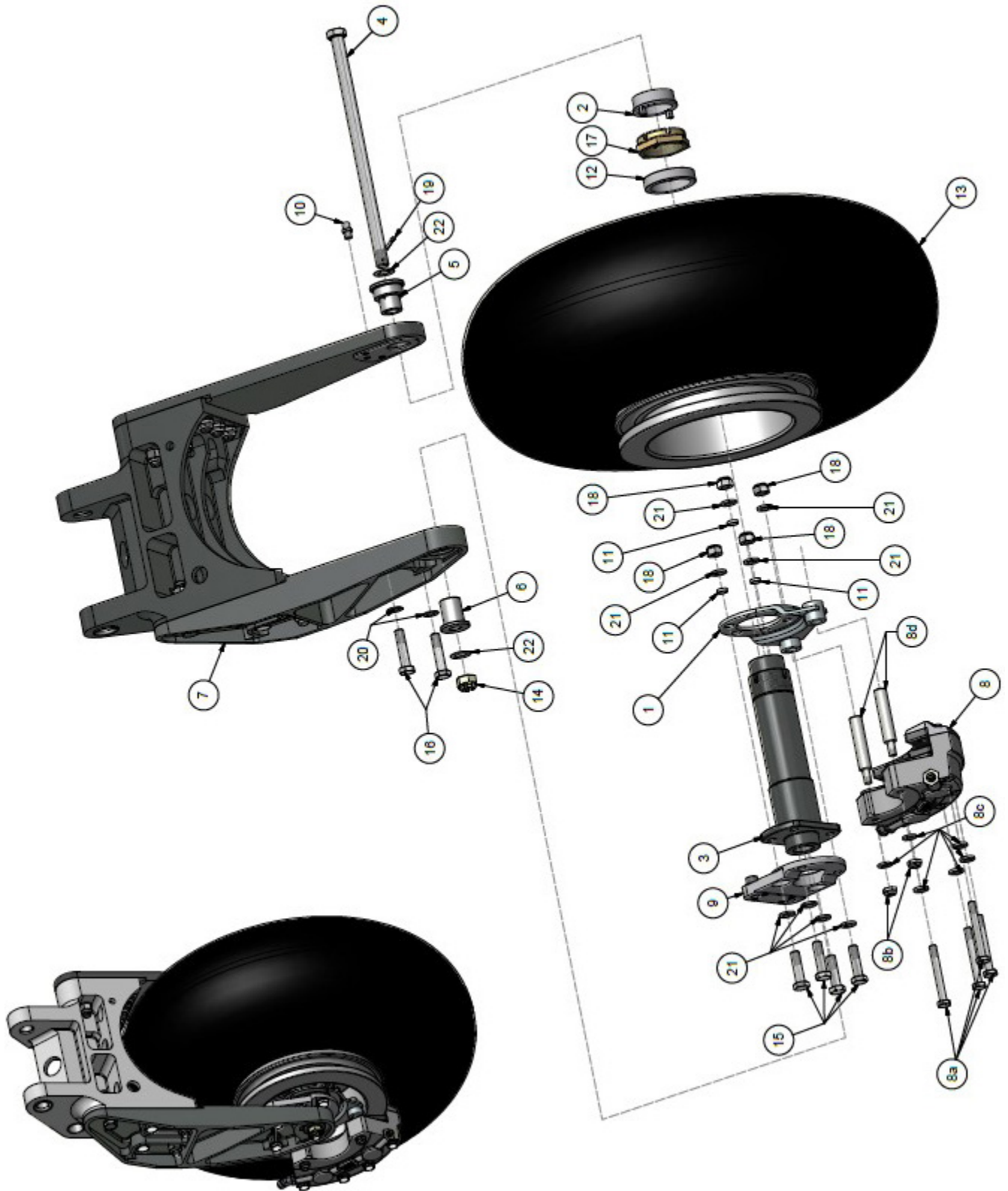

ITEM	QTY	PART NO.	PART DESCRIPTION
-	1	1004288	ASS'Y., PIVOT, RH, MAIN GEAR
-	1	1005377	ASS'Y., PIVOT, LH, MAIN GEAR
1	1	075-20700	TORQUE PLATE
2	1	1004281	LOCKING HUB, MAIN
3	1	1004283	AXLE, MAIN GEAR
4	1	1005374	BOLT - 7/16-20 UNF-3A, 8.20 GRIP
5	1	1005378	HUB, AXLE
6	1	1005389	HUB, AXLE
7	1	1005746	ASS'Y., PIVOT, RH, MAIN GEAR W/O WHEEL
	1	1005747	ASS'Y., PIVOT, LH, MAIN GEAR W/O WHEEL
8	1	1005844	BRAKE ASSEMBLY COMPLETE, RH
	1	1005775	BRAKE ASSEMBLY COMPLETE, LH
8a	4	AN4H21A	BOLT
8b	2	MS21083N4	NUT
8c	6	NAS1149F0463P	WASHER
8d	2	069-03100	BOLT - ANCHOR
9	1	1005855	ASSY, BRACKET, ANTI ROTATION, MAIN, 3000 3450
10	1	1095K41	COMMON GREASEZERK
11	3	30A04523-002	BUSHING, TORQUE PLATE
12	1	6A04093-002	AXLE SPACER, MAIN WHEEL
13	1	8A04000-031	MAIN WHEEL ASSEMBLY
14	1	AN310-7	NUT, HEX, CASTLE, 7/16-20 UNF
15	4	AN5-11A	BOLT
16	2	AN5-13A	BOLT
17	1	MS21025-24	NUT, AXLE
18	6	MS21044N5	NUT
19	1	MS24665-302	COTTER PIN
20	2	NAS1149F0532P	WASHER
21	12	NAS1149F0563P	WASHER
22	2	NAS1149F0732P	WASHER

## MAIN GEAR ASSEMBLY

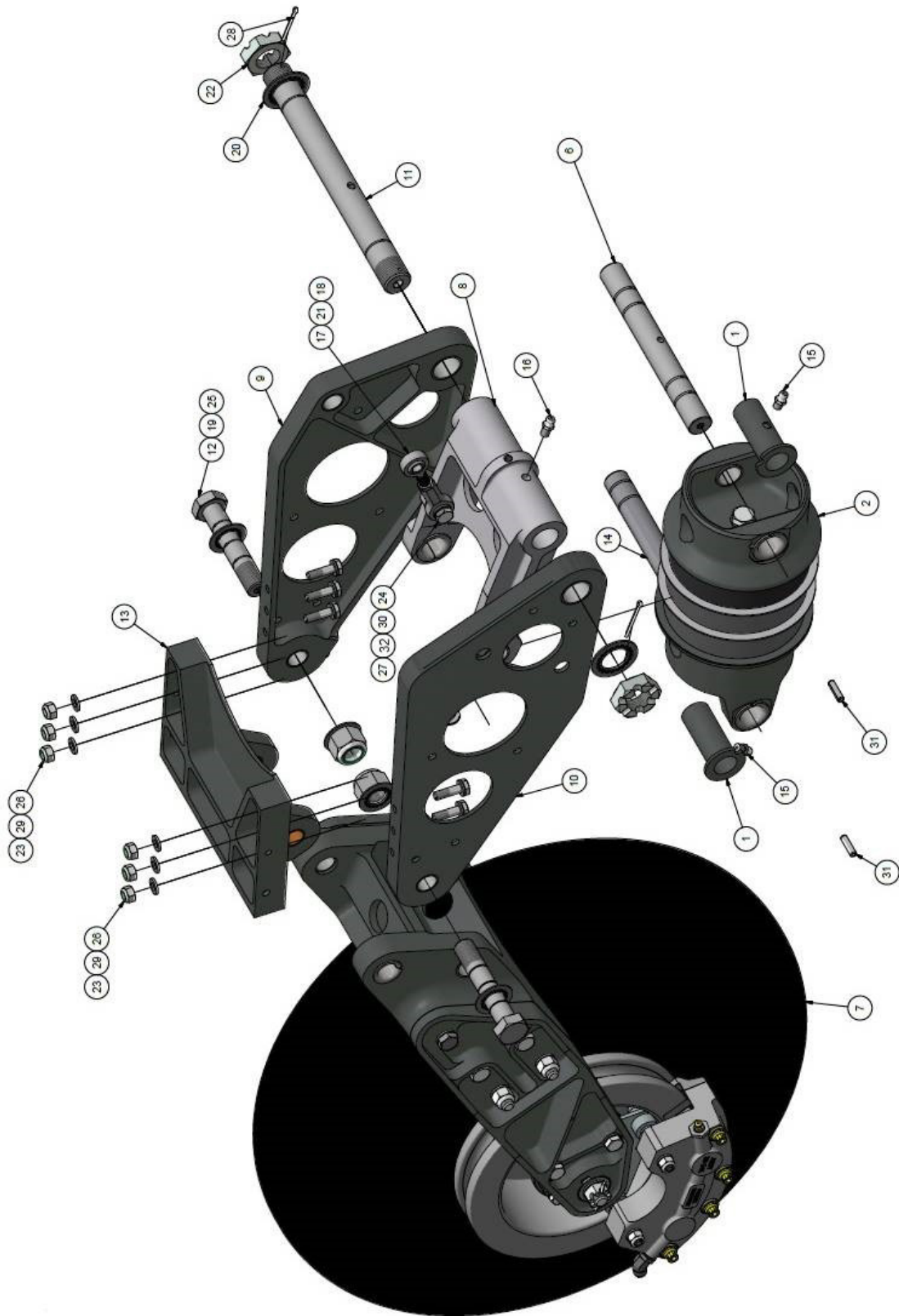

ITEM	QTY	PART NO.	PART DESCRIPTION
-	1	1004291-04	ASS'Y, MAIN GEAR, RIGHT, HEAVY DUTY, 3450
-	1	1004251-04	ASS'Y, MAIN GEAR, LEFT, 3450
1	2	1004263	RETAINER, MAIN
2	1	1004286-04	ASS'Y., SHOCK, LIGHT DUTY, MAIN GEAR
6	1	1004287	ASS'Y., PIVOT PIN, SHOCK, UPPER, MAIN
7	1	1004288	ASSY, PIVOT, RH, MAIN GEAR
	1	1005377	ASS'Y., PIVOT, LH, MAIN GEAR
8	1	1004289	ASS'Y., UPPER SHOCK LINK
9	1	1004882	ASS'Y., SIDE SUPPORT, LH, MAIN
10	1	1005375	ASS'Y., SIDE SUPPORT, RH, MAIN
11	1	1005733	ASSEMBLY, SHAFT, UPPER SHOCK, MAIN GEAR
12	2	1005734	ASSEMBLY, BOLT, MODIFIED, LOWER PIVOT
13	1	1005735	ASSEMBLY, SUPPORT, PIVOT, LOWER, MAIN GEAR
14	1	1005750	ASS'Y., PIVOT PIN, SHOCK, LOWER, MAIN
15	4	1095K41	COMMON GREASEZERK
16	1	1095K42	COMMON GREASEZERK
17	1	59915K273	BALL JOINT ROD END, 5/16" BALL ID, MALE
18	1	59915K483	BALL JOINT END, 5/16" BALL ID, FEMALE
19	4	93781A035	SEALING WASHER
20	2	93783A046	SEALING WASHER
21	1	AN316-4R	NUT
22	2	AN320-14	NUT, HEX, SLOTTED, 7/8-14 UNF
23	6	AN4-7A	BOLT
24	1	AN-16A	BOLT
25	2	MS21044N10	NUT
26	6	MS21044N4	NUT
27	1	MS21083N6	NUT
28	2	MS24665-304	COTTER PIN
20	12	NAS1149F0463P	WASHER
30	2	NAS1149F0632P	WASHER
31	2	NAS561P6-12	COTTER PIN
32	1	NAS1149F0663P	WASHER THICK

## MAIN GEAR ROTARY ACTUATOR ASSEMBLY

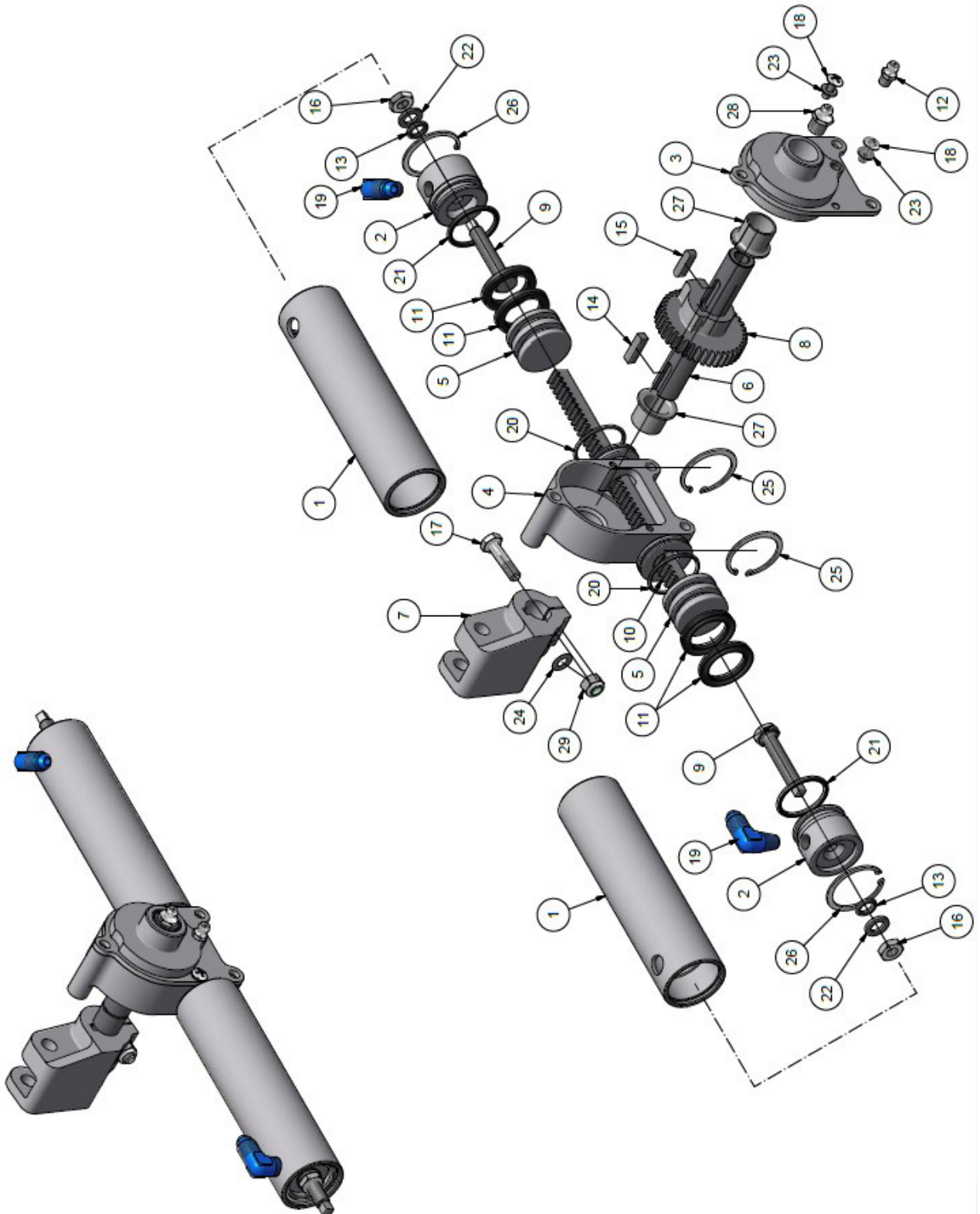



ITEM	QTY	PART NO.	PART DESCRIPTION
-	1	1005271	ASSMEBLY, ROTARY ACUTATOR, MAIN GEAR
1	2	1005272	CYLINDER, ROTARY ACTUATOR, MAIN GEAR
2	2	1005273	CYLINDER CAP, ROTARY ACTUATOR, MAIN GEAR
3	1	1005274	HOUSING TOP, ROTARY ACTUATOR, MAIN GEAR
4	1	1005275	HOUSING, ROTARY ACTUATOR, MAIN GEAR
5	2	1005276	PISTON, ROTARY ACTUATOR, MAIN GEAR
6	1	1005277	SHAFT, ROTARY ACTUATER, MAIN GEAR
7	1	1005280	ARM, GEAR ACTUATOR, 3000 3450
8	1	1005282	SPUR GEAR, PDIA 2.00 BORE .625 MODIFIED
9	2	1005283	BOLT, 5/16-24 UNF X 1.5, W/ 1/8 DRIVE, SST, MODIFIED
10	1	1005284	RACK, MOD, ROTARY ACTUATOR, MAIN GEAR
11	4	1005285	SEAL, U-CUP, .156 C/S, .937 ID, 1.250 OD, 90 DURO,
12	1	1095K41	GREASE ZERK
13	2	5018T168	5018T168
14	1	98870A330	KEY, 3/16 X 3/16 X .75 LG, 1018 STL, .002 OVER SIZED
15	1	98870A570	KEY, 3/16 X 3/16 X .75 LG, 1018 STL, .002 OVER SIZED
16	2	AN316C5R	NUT
17	1	AN4-10A	BOLT
18	2	AN526C832R8	SCREW, MACHINE, TRUSS HEAD
19	2	MS20822-4D	ELBOW
20	2	MS28775-024	"O" RING
21	2	MS28775-121	"O" RING
22	2	NAS1149C0563R	WASHER
23	2	NAS1149CN832R	WASHER
24	1	NAS1149D0416J	WASHER
25	2	MS16625-4125	RETAINING RING, INTERNAL
26	2	MS16625-4131	RETAINING RING, INTERNAL
27	2	10FDU10	FLANGED BUSHING
28	1	1095K11	GREASE ZERK
29	1	MS21044N4	NUT



# SECTION 9

## STRUTS, WIRES, STEPS, AND SPREADER BARS

### CONTENTS

STRUTS, WIRES, AND SPREADER BARS.....	102
STEPS INSTALLATION .....	105

## STRUTS, WIRES, AND SPREADER BARS

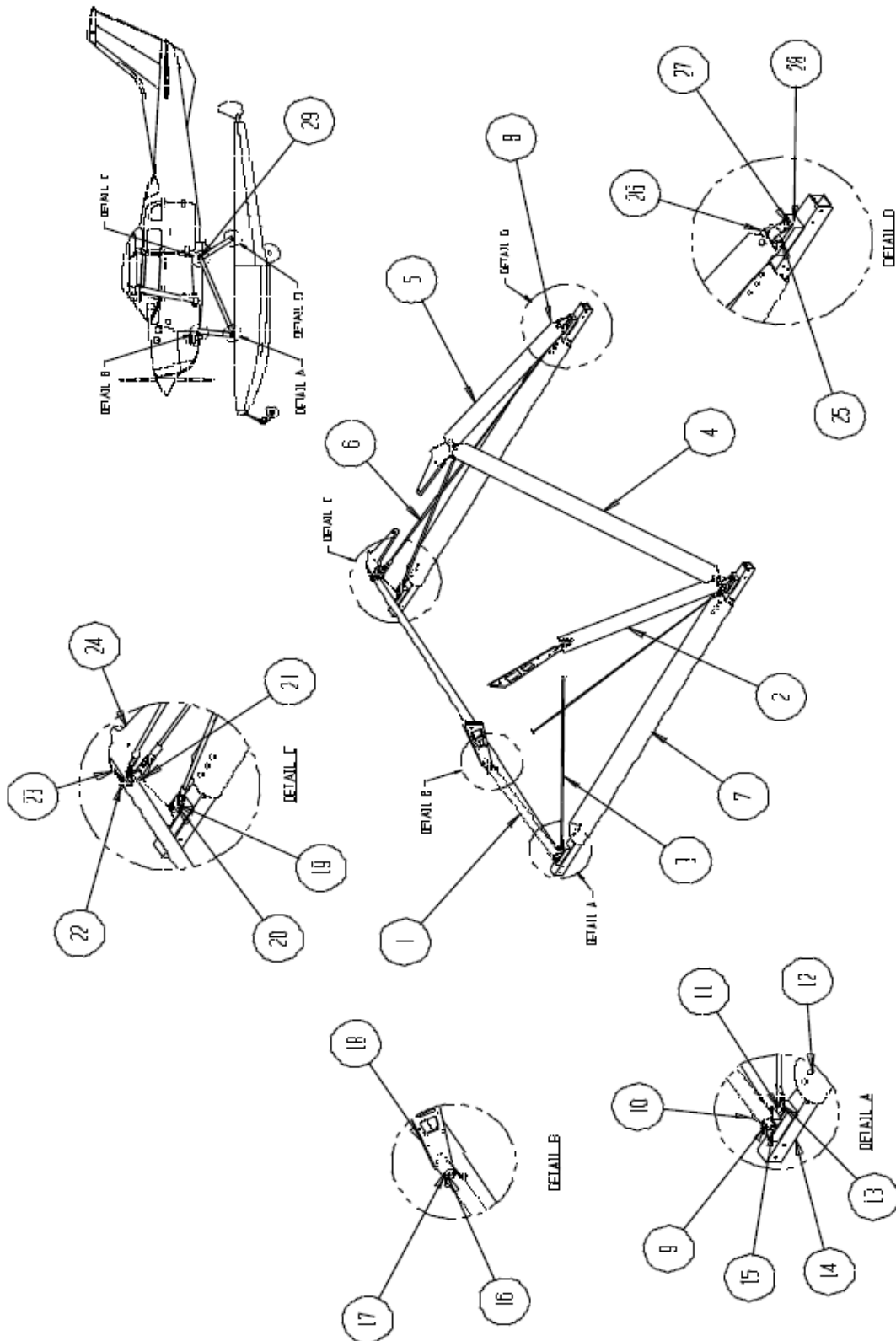

PARTS MANUAL  
3450 FLOATS ON CESSNA 206

ITEM	QTY	PART NO.	PART DESCRIPTION
1	1	34A02000-218	FWD RH STRUT
2	1	34A02000-197	FWD LH STRUT
3	2	30A02000-235	DRAG WIRE - FRONT
	1	AN665-80LAS *	TERMINAL L.H.
	1	AN316-C6L	CHECK NUT
	1	AN665-80RAS *	TERMINAL R.H.
	1	AN316-C6R	CHECK NUT
	2	MS20392-5C21	CLEVIS PIN
	2	MS24665-301	COTTER PIN
4	2	34A02000-198	DIAG. STRUT
5	2	34A02000-199	REAR STRUT
6	2	34A02000-209	DRAG WIRE - REAR
	1	AN665-115LS *	TERMINAL L.H.
	1	AN316-C7L	CHECK NUT
	1	AN665-115RS *	TERMINAL R.H.
	1	AN316-C7R	CHECK NUT
	2	MS20392-6C25	CLEVIS PIN
	2	MS24665-370	COTTER PIN
7	2	30A03000-031	SPREADER BAR
8	2	21A04000-080	BRAKE LINE
	2	63-1906000-3	STRAIGHT FITTING
9	1	34A02204-013	FITTING – FWD LOWER LH
	1	34A02204-012	FITTING – FWD LOWER RH
10	8	AN7-22A	BOLT (SERIAL #S 34079, 34080, 34093 AND UP)
	8	AN7-20A	BOLT (ALL OTHER SERIAL #S)
	16	NAS1149F0763P	WASHER
	8	MS20365-720A	NUT
11	2	AN6-43A	BOLT – DRAG WIRE LUG
	4	NAS1149F0663P	WASHER
	2	MS21044N6	NUT
12	12	<b>AN6-30A</b>	BOLT – SPREADER BAR ATTACH
	24	NAS1149D0663J	WASHER
	12	MS21044N6	NUT
13	2	1004807	LUG – DRAG WIRE
14	1	30A03319-001	TUBE – SPR. FLOAT LH
	1	30A03319-002	TUBE – SPR. FLOAT RH
15	2	AN7-33A	BOLT – LOWER STRUT ATTACH
	4	NAS1149F0763P	WASHER
	2	MS21044N7	NUT
16	2	AN8-20A	BOLT
	4	NAS1149F0863P	WASHER

ITEM	QTY	PART NO.	PART DESCRIPTION
	2	MS21044N8	NUT
17	2	34A02229-005	FITTING – FWD UPPER STRUT
18	2	4A02078-001	FITTING – FWD FUSELAGE
19	2	AN7-43A	BOLT – DRAG WIRE LUG ATTACH
	2	NAS1149F0563P	WASHER
	2	MS21044N5	NUT
20	2	34A02496-003	LUG – DRAG WIRE ATTACH
21	2	4A02000-073	ASS'Y – FITTING – DRAGWIRE LH
	2	4A02000-074	ASS'Y – FITTING – DRAGWIRE RH
22	2	AN8-22A	BOLT (SERIAL #'S 34079, 34080, 34093 AND UP) - FWD
	2	AN8-20A	BOLT (ALL OTHER SERIAL #'S)
	2	NAS1149F0863P	WASHER
23	2	AN8-22A	BOLT (SERIAL #'S 34079, 34080, 34093 AND UP) - AFT
	2	AN8-20A	BOLT (ALL OTHER SERIAL #'S)
	4	NAS1149F0863P	WASHER
	2	MS21044N8	NUT
24	1	34A02062-013	TONGUE – LH
	1	34A02062-012	TONGUE – RH
25	2	AN7-30A	BOLT – REAR STRUT ATTACH
	4	NAS1149F0763P	WASHER
	2	MS21044N7	NUT
26	2	34A02204-014	FITTING – AFT LOWER STRUT
27	4	AN6-41A	BOLT – ITEM 28 ATTACH
	8	NAS1149F0663P	WASHER
	4	MS21044N6	NUT
28	2	30A02219-003	FITTING – FLOAT DECK
29	1	3A02005-030	GEAR OPENING COVER RT
	1	3A02005-031	GEAR OPENING COVER LT

"S" DENOTES STAINLESS STEEL

## STEPS INSTALLATION

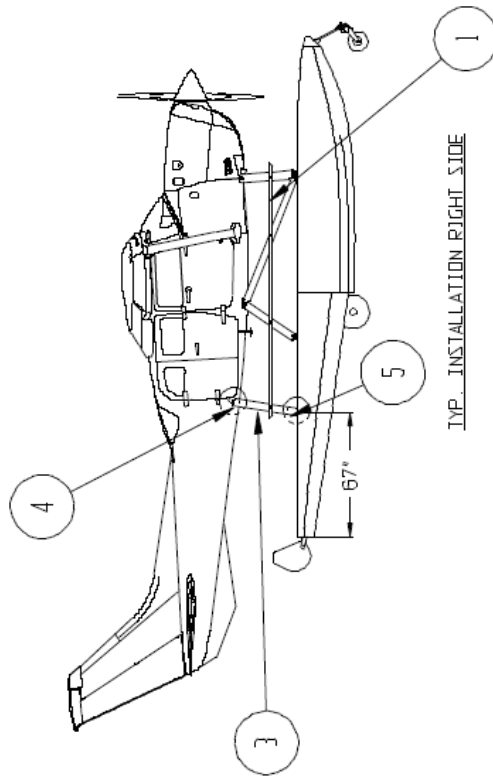

TYP. INSTALLATION RIGHT SIDE

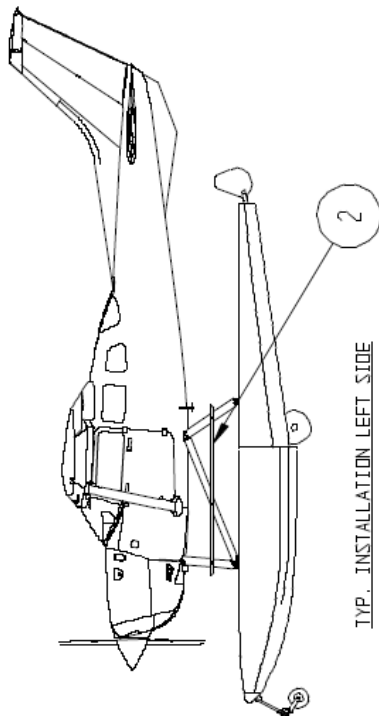

TYP. INSTALLATION LEFT SIDE

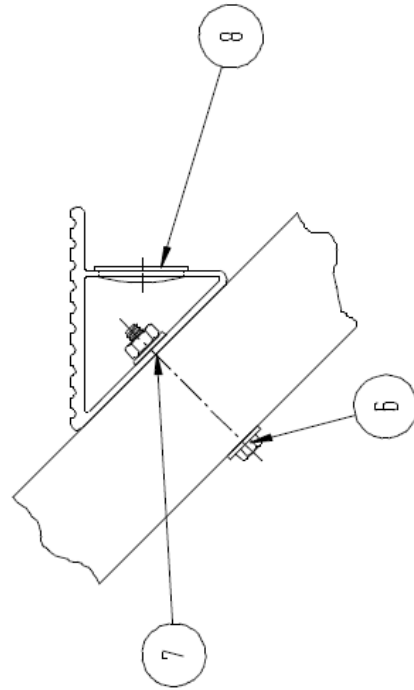

ITEM	QTY	PART NO.	PART DESCRIPTION
1	1	34A02369-048	STEP – R.H.
2	1	4A02369-009	STEP – L.H.
3	1	34A02000-212	ASS'Y STRUT
	1	34A02334-045	STRUT
	1	8A02053-007	FITTING – UPPER
	1	8A02053-005	FITTING - LOWER
	A/R	MS24694S145	SCREW – FITTING ATTACH
4	1	AN44-5A	EYE BOLT – UPPER ATTACH
	2	NAS1149F0563P	WASHER
	1	MS21044N5	NUT
5	1	8A02273-007	FITTING - SLIDE
	1	AN44-5A	EYE BOLT (FLOAT)
	1	NAS1149F0532P	WASHER
	1	MS21044N5	NUT
	1	AN4-12A	BOLT – SLIDE TO EYE BOLT
	1	NAS1149F0463P	WASHER
	1	MS21083N4	NUT
6	4	AN3-21A	BOLT – ATTACH F & R STRUT
	2	AN3-24A	BOLT – ATTACH CENTER STRUT
	1	AN3-24A	BOLT – ATTACH
	14	NAS1149F0332P	WASHER
	7	MS21044N3	BOLT
7	4	6A02273-006	SPACER (BETWEEN STEP & STRUT – NOT SHOWN)
8	6	BPF	HOLE PLUGS (WHITE)

## SECTION 10

# HYDRAULIC SYSTEM

### CONTENTS

HYDRAULIC PUMP (FWD NOSE WHEEL WELL) INSTALLATION POST SERVICE LETTER 241 .....	108
HYDRAULIC PUMP (FWD NOSE WHEEL WELL) ASSEMBLY POST SERVICE LETTER 241.....	110
ELECTRONIC SIDE PLATE (FWD NOSE WHEEL WELL) ASSY POST SERVICE LETTER 241 .....	113
HYDRAULIC SYSTEM INSTALLATION POST SERVICE LETTER 221.....	115
HYDRAULIC SYSTEM INSTALLATION PRE SERVICE LETTER 221 .....	117
HYDRAULIC PUMP ASSEMBLY POST SERVICE LETTER 221 .....	119
HYDRAULIC PUMP ASSEMBLY SUPPORT PLATE 24V POST SERVICE LETTER 221.....	122
HYDRAULIC PUMP ASSEMBLY PRE SERVICE LETTER 221 .....	124
HYDRAULIC PUMP FIREWALL (SOLOY ONLY) INSTALLATION POST SERVICE LETTER 242 .....	127
HYDRAULIC PUMP FIREWALL (SOLOY ONLY) ASSEMBLY POST SERVICE LETTER 242 .....	129
ASSEMBLY SUPPORT PLATE FIREWALL (SOLOY ONLY) POST SERVICE LETTER 242 .....	132
HYDRAULIC PUMP OVERVIEW POST SERVICE LETTER 221.....	134
HYDRAULIC PUMP OVERVIEW PRE SERVICE LETTER 221 .....	136
HYDRAULIC PUMP SCHEMATIC .....	138

# HYDRAULIC PUMP (FWD NOSE WHEEL WELL) INSTALLATION POST SERVICE LETTER 241

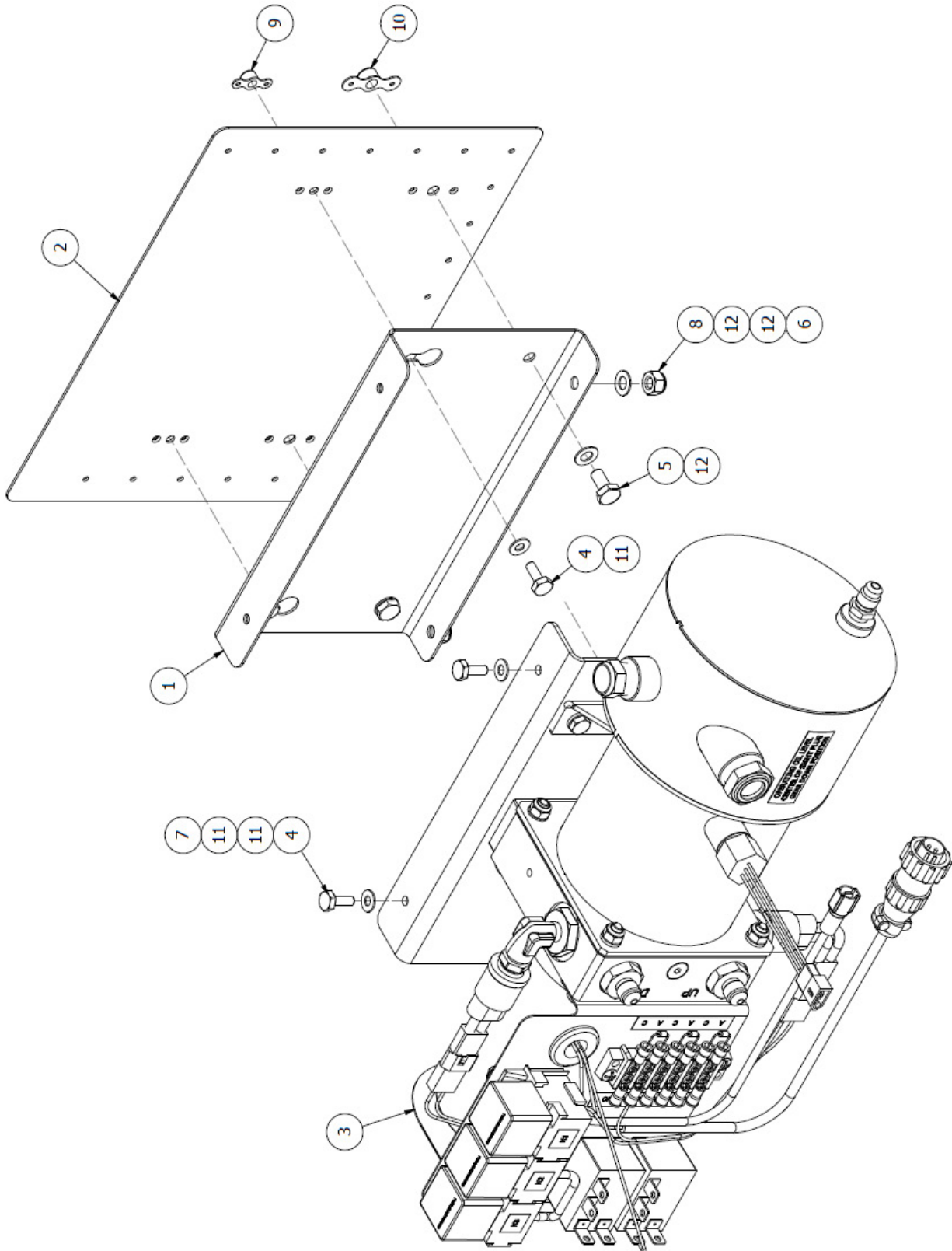



PARTS MANUAL  
3450 FLOATS ON CESSNA 206

ITEM	QTY	PART NO.	PART DESCRIPTION
1	1	1006582	BRACKET, HYDRAULIC POWER PACK, C-206, FWD MOUNT
2	1	1006583	DOUBLER, HYDRAULIC POWER PACK, C-206, FWD MOUNT
3 (12V)	1	1011938	ASSEMBLY, HYDRAULIC POWER PACK, 12V
3 (24V)	1	1011939	ASSEMBLY, HYDRAULIC POWER PACK, 24V
4	4	AN3-4A	BOLT, 10-32, 0.125 GRIP, UNDRILLED, STEEL
5	2	AN4-4A	BOLT, 1/4-28, 0.0625 GRIP, UNDRILLED, STEEL
6	2	AN4-5A	BOLT, 1/4-28, 0.1875 GRIP, UNDRILLED, STEEL
7	2	MS21044N3	NUT, LOCKING, REGULAR HEIGHT, 10-32 UNF
8	2	MS21044N4	NUT, LOCKING, REGULAR HEIGHT, 1/4-28 UNF
9	2	MS21047L3	NUT PLATE, FIXED, STEEL, PLAIN, 10-32
10	2	MS21047L4	NUT PLATE, FIXED, STEEL, PLAIN, 1/4-28
11	6	NAS1149F0332P	WASHER, 0.203 ID, 0.032 THK, STEEL
12	6	NAS1149F0432P	WASHER, 0.265 ID, 0.032 THK, STEEL

# HYDRAULIC PUMP (FWD NOSE WHEEL WELL) ASSEMBLY

## POST SERVICE LETTER 241

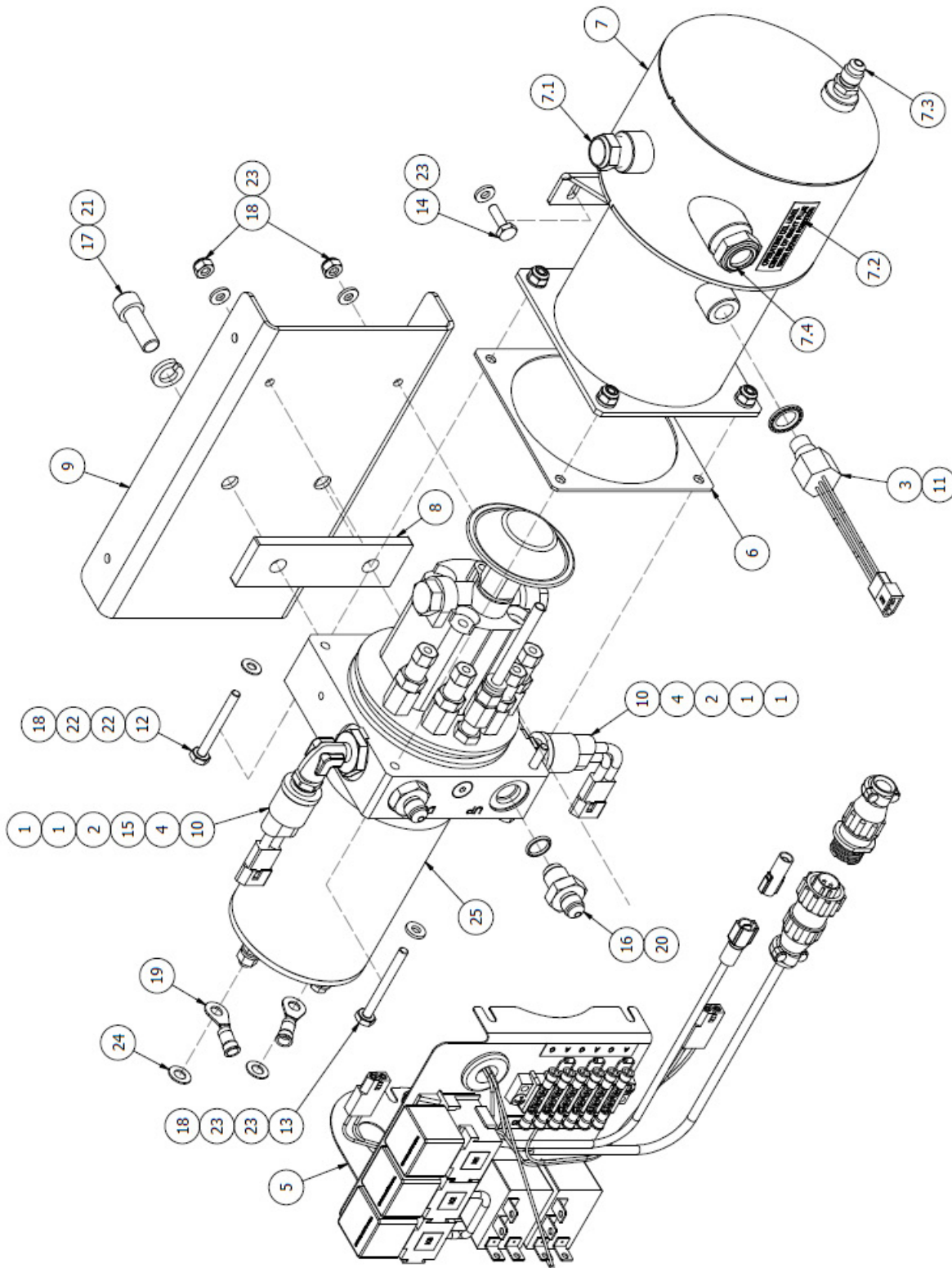

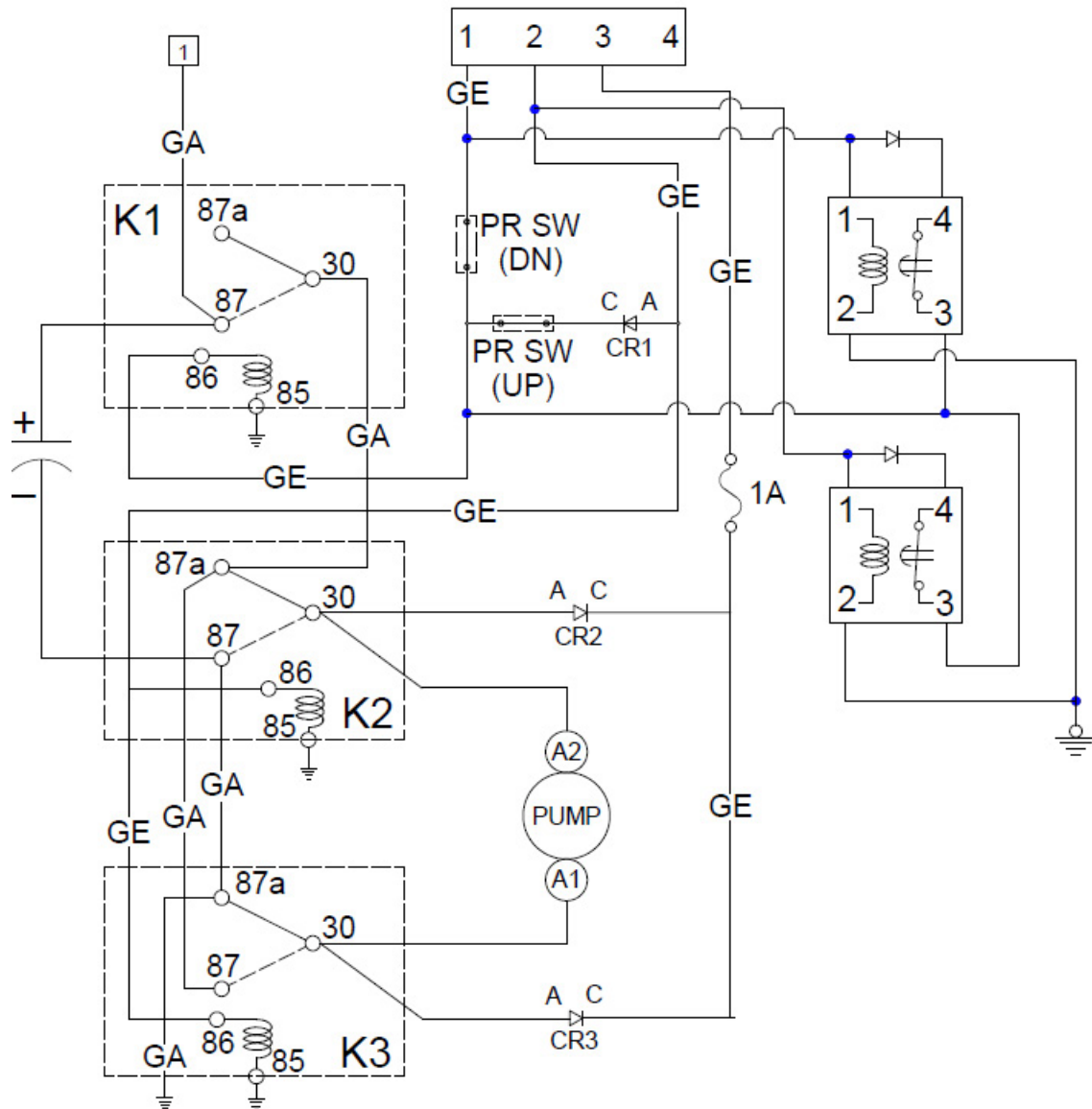

POWER PACK SCHEMATIC  
 (RELAYS SHOWN IN RELAXED CONDITION)  
 1. GE WIRES 20 GA  
 2. GA WIRES 12 GA

ITEM	QTY	PART NO.	PART DESCRIPTION
-	1	1011938	ASSEMBLY, HYDRAULIC POWER PACK, 12V
-	1	1011939	ASSEMBLY, HYDRAULIC POWER PACK, 24V
1	4	02-09-2118	PIN, CRIMP MALE, 1/8" DIA
2	2	03-09-2022	CONNECTOR PLUG, FEMALE
3	1	1009428	ASSEMBLY, SENSOR, FLUID LEVEL
4	2	1011062	ASSEMBLY, PLUG, PRESSURE SWITCH PORT
5 (12V)	1	1011932	ASSEMBLY, ELECTRONIC SIDE PLATE, 12V
5 (24V)	1	1011933	ASSEMBLY, ELECTRONIC SIDE PLATE, 24V
6	1	1011934	GASKET, HYDRAULIC RESERVOIR
7	1	1011935	ASSEMBLY, HYDRAULIC RESERVOIR
7.1	1	1EJT7	BREATHER VENT
7.2	1	1011848	PLACARD, OIL LEVEL
7.3	1	AN816-4D	NIPPLE, FLARED TUBE AND PIPE THREAD
7.4	1	LSP151-04-01	LIQUID LEVEL SIGHT PLUG
8	1	1011936	SPACER
9	1	1011937	MOUNTING BRACKET, HYDRAULIC PUMP
10	2	20PS001EB 700W500W	PRESSURE SWITCH
11	1	93786A200	PRESSURE-SEALING WASHER, M12
12	2	AN3-16A	BOLT, 10-32, 1.375 GRIP, UNDRILLED, STEEL
13	2	AN3-17A	BOLT, 10-32, 1.5 GRIP, UNDRILLED, STEEL
14	2	AN3-5A	BOLT, 10-32, 0.25 GRIP, UNDRILLED, STEEL
15	1	AN914-1D	ELBOW, 90 DEGREE, INTERNAL EXTERNAL PIPE
16	2	AN919-3D	FITTING, REDUCER
17	2	MS16997-99	SCREW, CAP, SOCKET HEAD
18	6	MS21044N3	NUT, LOCKING, REGULAR HEIGHT, 10-32 UNF
19	2	MS25036-157	RING TERMINAL, 1/4 STUD, 10-12 AWG, YELLOW
20	2	MS28775-013	"O" RING, HYDRAULIC
21	2	MS35338-46	WASHER, SPLIT
22	4	NAS1149F0332P	WASHER, 0.203 ID, 0.032 THK, STEEL
23	8	NAS1149F0363P	WASHER, 0.203 ID, 0.063 THK, STEEL
24	2	NAS1149F0432P	WASHER, 0.265 ID, 0.032 THK, STEEL
25 (12V)	1	YBZS- C0.63W1T100K/ UVZOT2	HYDRAULIC POWER PACK, 12VDC, .64 PUMP
25 (24V)	1	YBZS- C0.63W2T100K/ UVZOT2	HYDRAULIC POWER PACK, 24VDC, .64 PUMP

## ELECTRONIC SIDE PLATE (FWD NOSE WHEEL WELL) ASSEMBLY POST SERVICE LETTER 241

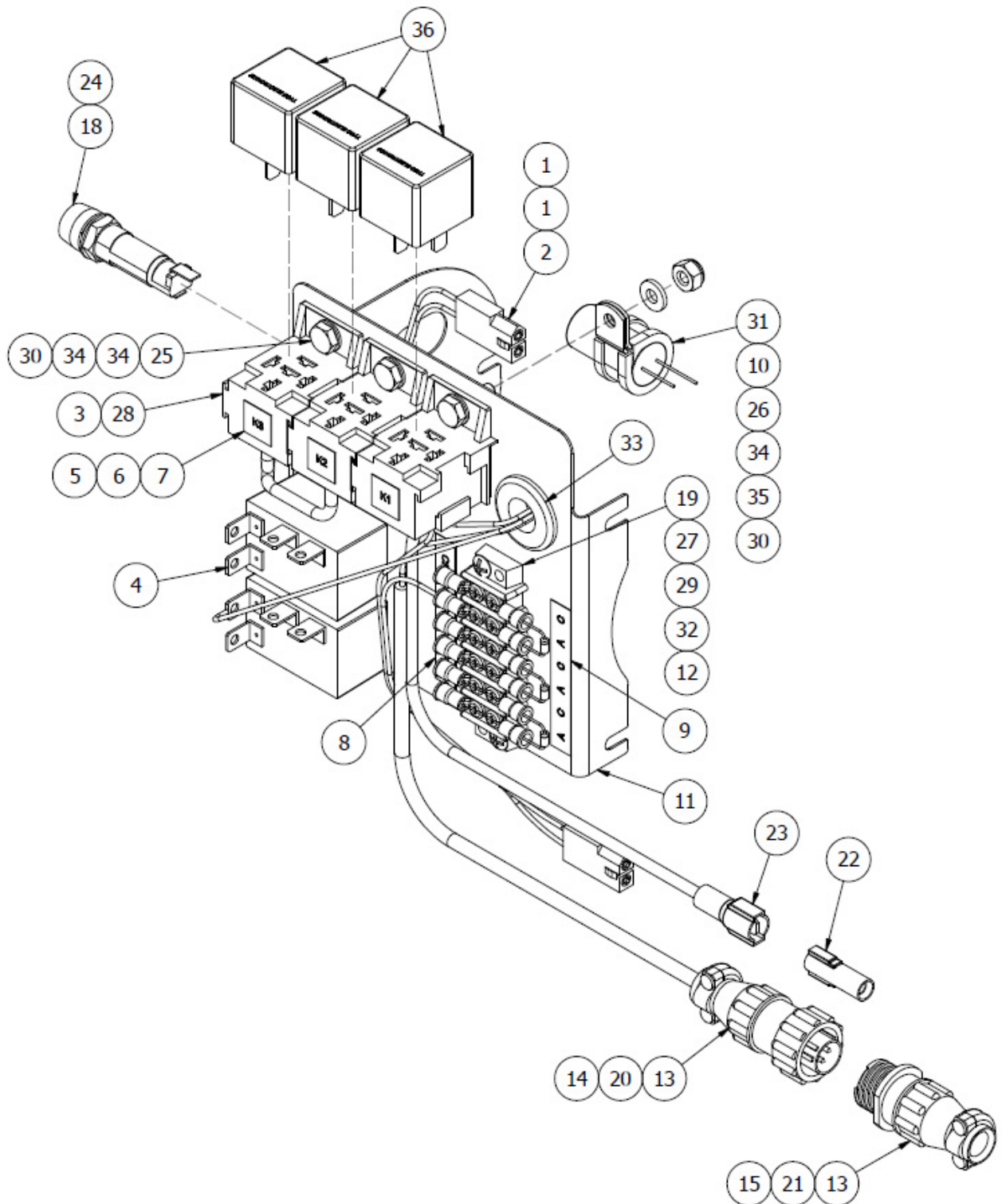

ITEM	QTY	PART NO.	PART DESCRIPTION
-	1	1011932	ASSEMBLY, ELECTRONIC SIDE PLATE, 12V
-	1	1011933	ASSEMBLY, ELECTRONIC SIDE PLATE, 24V
1	4	02-09-1104	PIN, CRIMP, FEMALE, 1/8" DIA
2	2	03-09-1022	CONNECTOR PLUG, MALE, 2 CONN.
3	14	1-901-355-917	TERMINAL
4 (12V)	1	1005042	TIMER RELAY HARNESS
4 (24V)	1	1005043	TIMER RELAY HARNESS
5	1	1009143-01	PLACARD, K1 INDICATOR
6	1	1009143-02	PLACARD, K2 INDICATOR
7	1	1009143-03	PLACARD, K3 INDICATOR
8	1	1009144-01	PLACARD, CR INDICATOR
9	1	1009144-02	PLACARD, AC INDICATOR
10	1	1011798	ASSEMBLY, CAPACITOR
11	1	1011931	ELECTRONIC SIDE PLATE, HYDRAULIC PUMP
12	3	1N4004	DIODE, 2-1/2"
13	2	206062-3	CLAMP, CABLE, CPC SIZE 11
14	1	206429-1	PLUG, MAL, CPC SIZE 1, 4 PIN
15	1	206430-2	CPC FREE HANG, 4 PIN, FEMALE
16	6 FT	22759-16-12-9	WIRE, 12 AWG, WHITE
17	10 FT	22759-16-20-9	WIRE, 20 AWG, WHITE
18	1	3453LF2A	FUSE HOLDER
19	1	6-140	TERMINAL BLOCK, 6 CONNECTOR
20	3	66103-4	PIN, CRIMP SOCKET, 24-20G
21	3	66105-4	CRIMP SOCKET, FEMALE
22	1	73F-250-32-NL	CONNECTOR, FEMALE, 10-12 AWG, FULLY INSULATED
23	1	73M-250-32-NL	CONNECTOR, MALE, 10-12 AWG, FULLY INSULATED
24	1	AGC-1	FUSE, 250V, (S2565-1)
25	2	AN3-3A	BOLT, 10-32, 0.0625 GRIP, UNDRILLED, STEEL
26	1	AN3-5A	BOLT, 10-32, 0.25 GRIP, UNDRILLED, STEEL
27	2	AN526C632R8	SCREW, MACHINE, TRUSS HEAD
28	3	BR05-FW	SOCKET, 5 PRONG, PLASTIC
29	2	MS21044N06	NUT, LOCKING, REGULAR HEIGHT, 6-32 UNC
30	3	MS21044N3	NUT, LOCKING, REGULAR HEIGHT, 10-32 UNF
31	1	MS21919WDG10	CLAMP, LOOP, CUSHIONED, 5/8 TUBE OD
32	12	MS25036-102	RING TERMINAL, #6 STUD, 16-22 AWG, RED
33	1	MS35489-14	GROMMET, 5/16 HOLE, 11/16 GROOVE DIA, .062 PANEL
34	5	NAS1149F0332P	WASHER, 0.203 ID, 0.032 THK, STEEL
35	1	NAS1149F0363P	WASHER, 0.203 ID, 0.063 THK, STEEL
36 (12V)	3	V23234- A0001-X032	RELAY, 12V, 5 PRONG
36 (24V)	3	0-332-209-211	RELAY, 24V, 5 PRONG

## HYDRAULIC SYSTEM INSTALLATION POST SERVICE LETTER 221

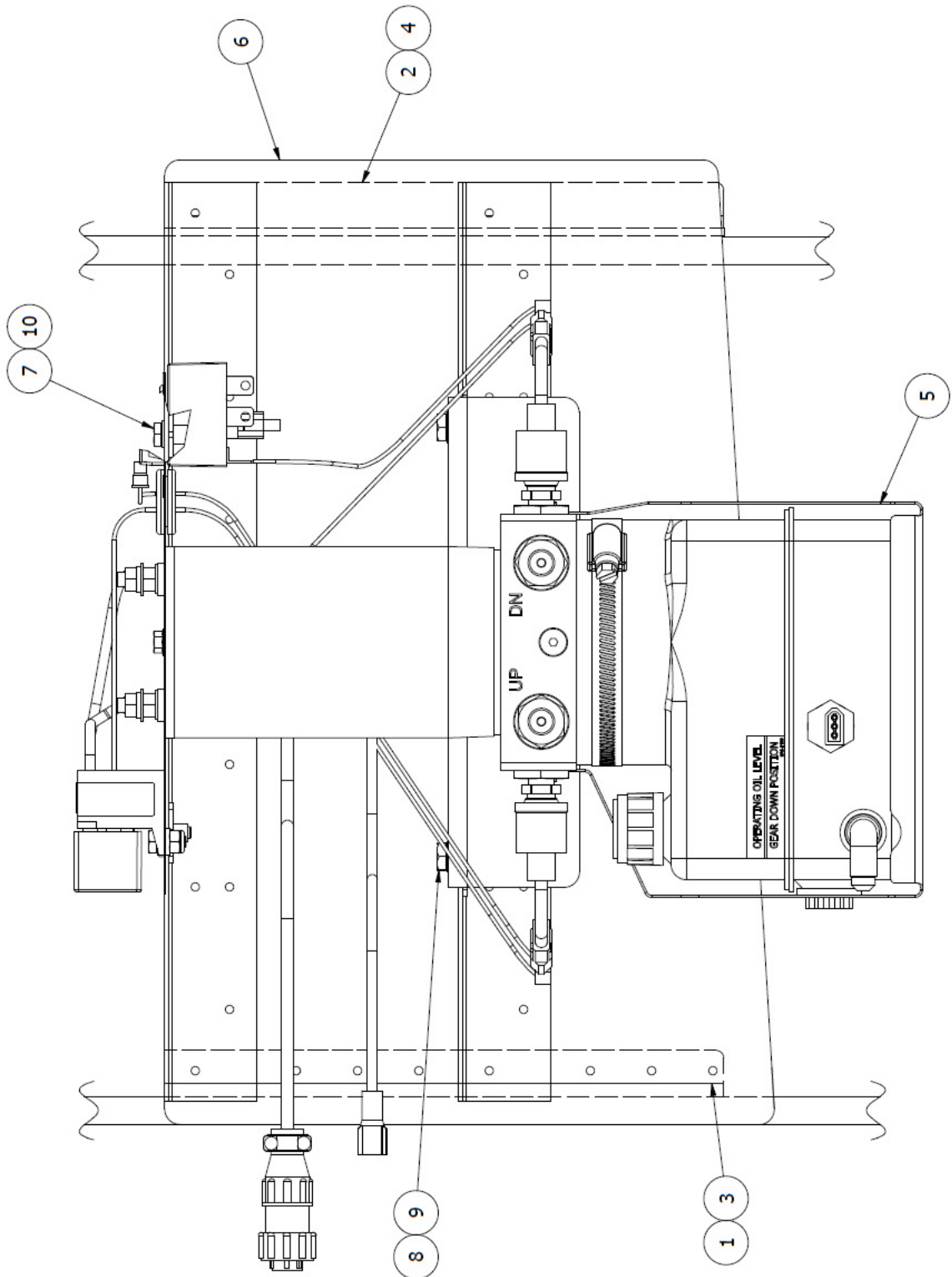

ITEM	QTY	PART NO.	PART DESCRIPTION
1	1	1001382	CHANNEL, FWD, HYD PUMP
2	1	1001383	CHANNEL, AFT, HYD PUMP
3	1	1004685	SPACER, CHANNEL, FWD
4	1	1004686	SPACER, CHANNEL, AFT
5 (12V)	1	1011439	ASSEMBLY, HYDRAULIC POWER PACK, 12V
5 (24V)	1	1011548	ASSEMBLY, HDYRAULIC POWER PACK, 24V
6 LT.	1	1001432	ASSEMBLY, PUMP MOUNT, L/H SIDE
6 RT.	1	34A09000-244	ASSEMBLY, PUMP MOUNT, R/H SIDE
7	2	AN3-3A	BOLT, 10-32, 0.0625 GRIP, UNDRILLED, STEEL
8	2	AN4-5A	BOLT, 1/4-28, 0.1875 GRIP, UNDRILLED, STEEL
9	2	NAS1149D0416J	WASHER, 0.265 ID, 0.016 THK, ALUMINUM
10	2	NAS1149F0332P	WASHER, 0.203 ID, 0.032 THK, STEEL



### HYDRAULIC SYSTEM INSTALLATION PRE SERVICE LETTER 221

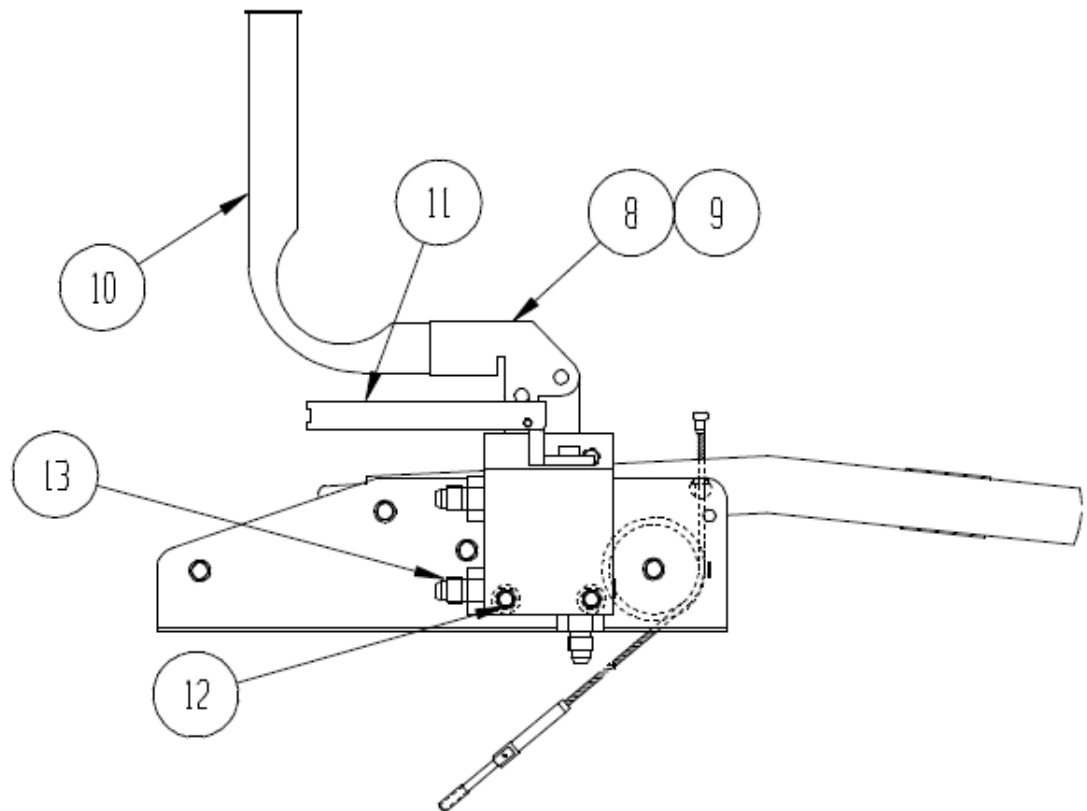
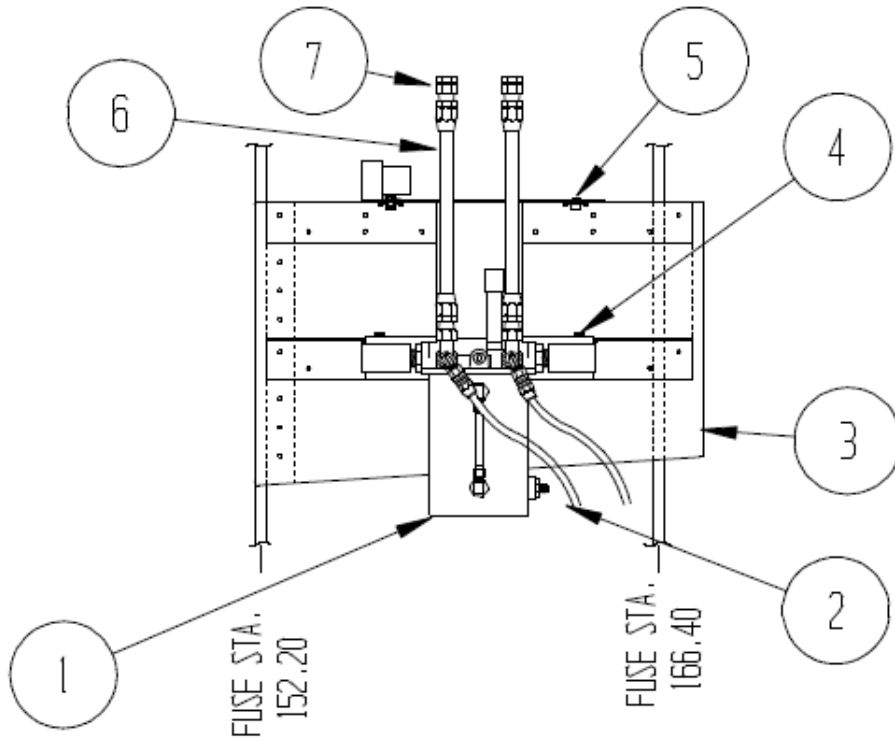

ITEM	QTY	PART NO.	PART DESCRIPTION
1	1	34A09000-245	ASS'Y – HYDRAULIC PUMP (12V)
	1	34A09000-277	ASS'Y – HYDRAULIC PUMP (24V)
2	2	34A09000-256	ASS'Y – HYDRAULIC HOSE
3	1	34A09000-244	ASS'Y – PUMP MOUNT
4	2	AN4-4A	BOLT – ATTACH - LOWER
	2	NAS1149D0416J	WASHER
5	2	AN3-3A	BOLT – ATTACH - UPPER
	2	NAS1149FO332P	WASHER
6	2	8A09000-048	ASS'Y – HOSE ACCUMULATOR
7	2	AN806-4D	PLUG – HOSE END
8	1	34A09000-261	ASS'Y – HAND PUMP (COMPLETE WITH RETRACT HANDLE)
9	1	638203	HAND PUMP ONLY
10	1	21A09396-001	HANDLE PUMP
11	1	21A12000-052	ASS'Y – HANDLE SELECTOR
	1	21A12414-005	HANDLE
	1	21A12214-004	PIVOT
	1	1/8 X 1"	ROLL PIN
	1	12A3-7379-1	PLACARD – HANDLE R. SIDE
12	2	MS16997-77	CAP – SCREW
	2	MS35333-40	WASHER
	2	NAS1149F0563J	WASHER
13	1	AN815-4D	UNION
	3	MS28775-012	O-RING
	1	AN916-6D	O-RING
	1	AN814-4D	O-RING

## HYDRAULIC PUMP ASSEMBLY POST SERVICE LETTER 221

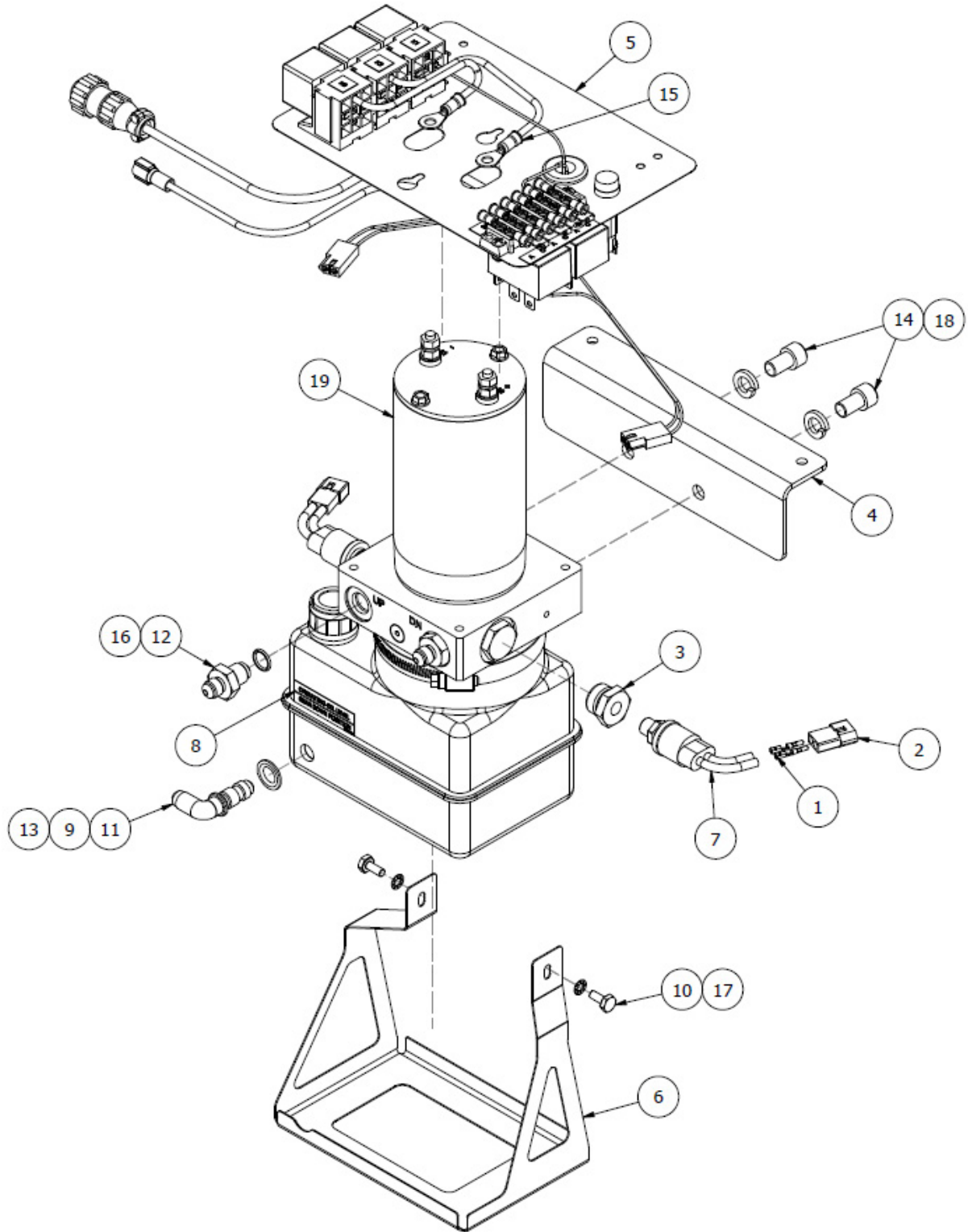

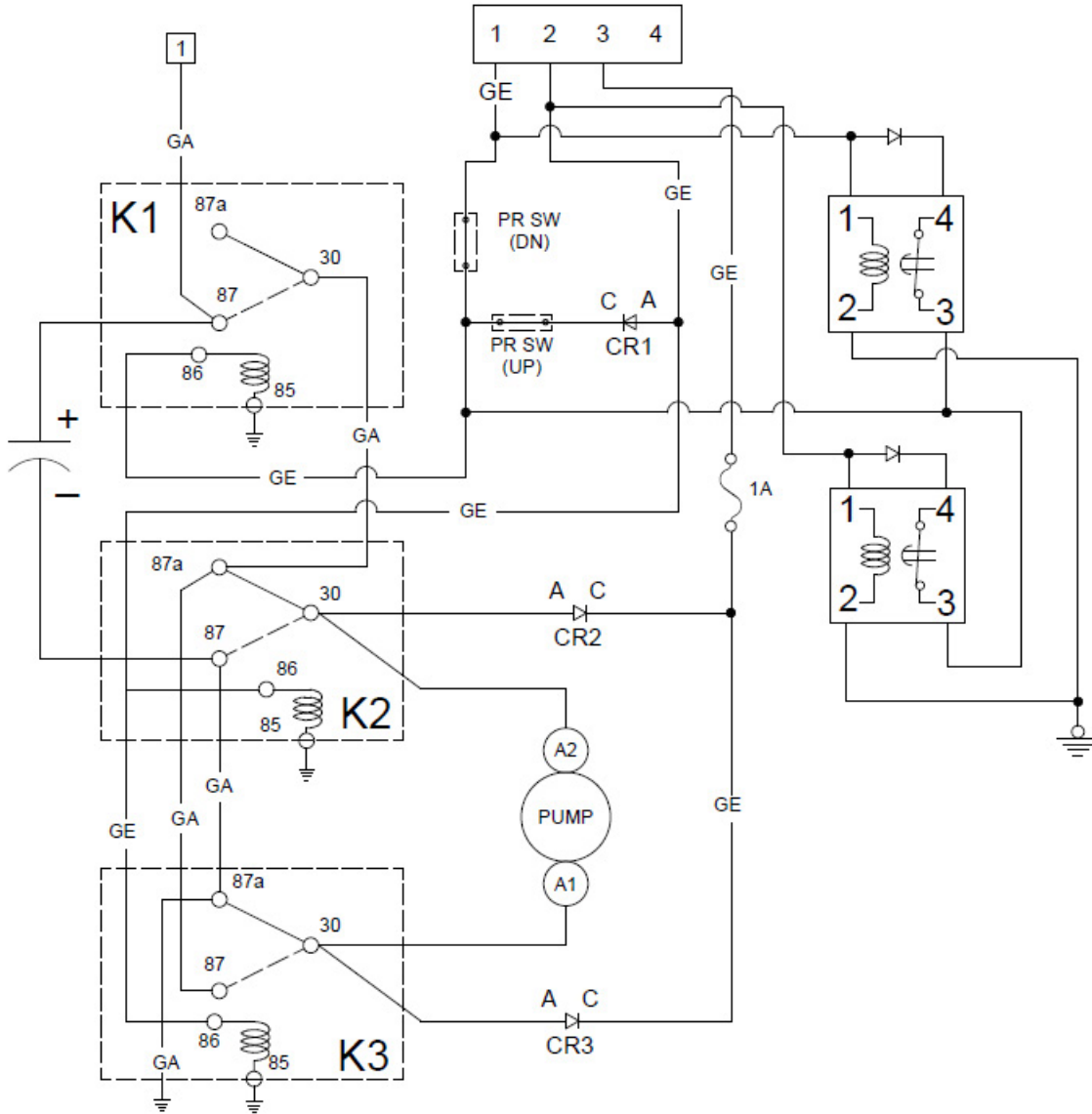

**POWER PACK SCHEMATIC  
(RELAYS SHOWN IN RELAXED CONDITION)**

1. GE WIRES 20 GA
2. GA WIRES 12 GA

PARTS MANUAL  
3450 FLOATS ON CESSNA 206

ITEM	QTY	PART NO.	PART DESCRIPTION
-	1	1011439	ASSEMBLY, HYDRAULIC POWER PACK, 12V
-	1	1011548	ASSEMBLY, HYDRAULIC POWER PACK, 24V
1	4	02-09-2118	PIN, CRIMP MALE, 1/8" DIA
2	2	03-09-2022	CONNECTOR PLUG, FEMALE
3	2	1011062	ASSEMBLY, PLUG, PRESSURE SWITCH PORT
4	1	1011447	ANGLE, MOUNT, LOWER
5 (12V)	1	1011449	ASSEMBLY, SUPPORT PLATE, HYDRAULIC PUMP, 12V
5 (24V)	1	1011547	ASSEMBLY, SUPPORT PLATE, HYDRAULIC PUMP, 24V
6	1	1011542	SUPPORT, HYDRAULIC RESERVOIR, SIDE MOUNT
7	2	20PS001E B700W500W	PRESSURE SWITCH
8	1	6A3-2199	PLACARD, OIL LEVEL
9	1	93783A032	SEALING WASHER
10	2	AN3-3A	BOLT, 10-32, 0.0625 GRIP, UNDRILLED, STEEL
11	1	AN833-4D	FITTING, HYDRAULIC, 90 DEGREE ELBOW
12	2	AN919-3D	FITTING, REDUCER
13	1	AN924-4D	JAM NUT
14	2	MS16997-96	SOCKET HEAD CAP SCREW
15	2	MS25036-157	RING TERMINAL, #10 STUD, 10-12 AWG, YELLOW
16	2	MS28775-013	"O" RING, HYDRAULIC
17	2	MS35333-39	STAR WASHER
18	2	MS35338-46	WASHER, SPLIT
19 (12V)	1	YBZS- C0.63W1T100K /UVZOT2	HYDRAULIC POWER PACK, 12VDC
19 (24V)	1	YBZS- C0.63W2T100K /UVZOT2	HYDRAULIC POWER PACK, 24VDC

## HYDRAULIC PUMP ASSEMBLY SUPPORT PLATE 24V POST SERVICE LETTER 221

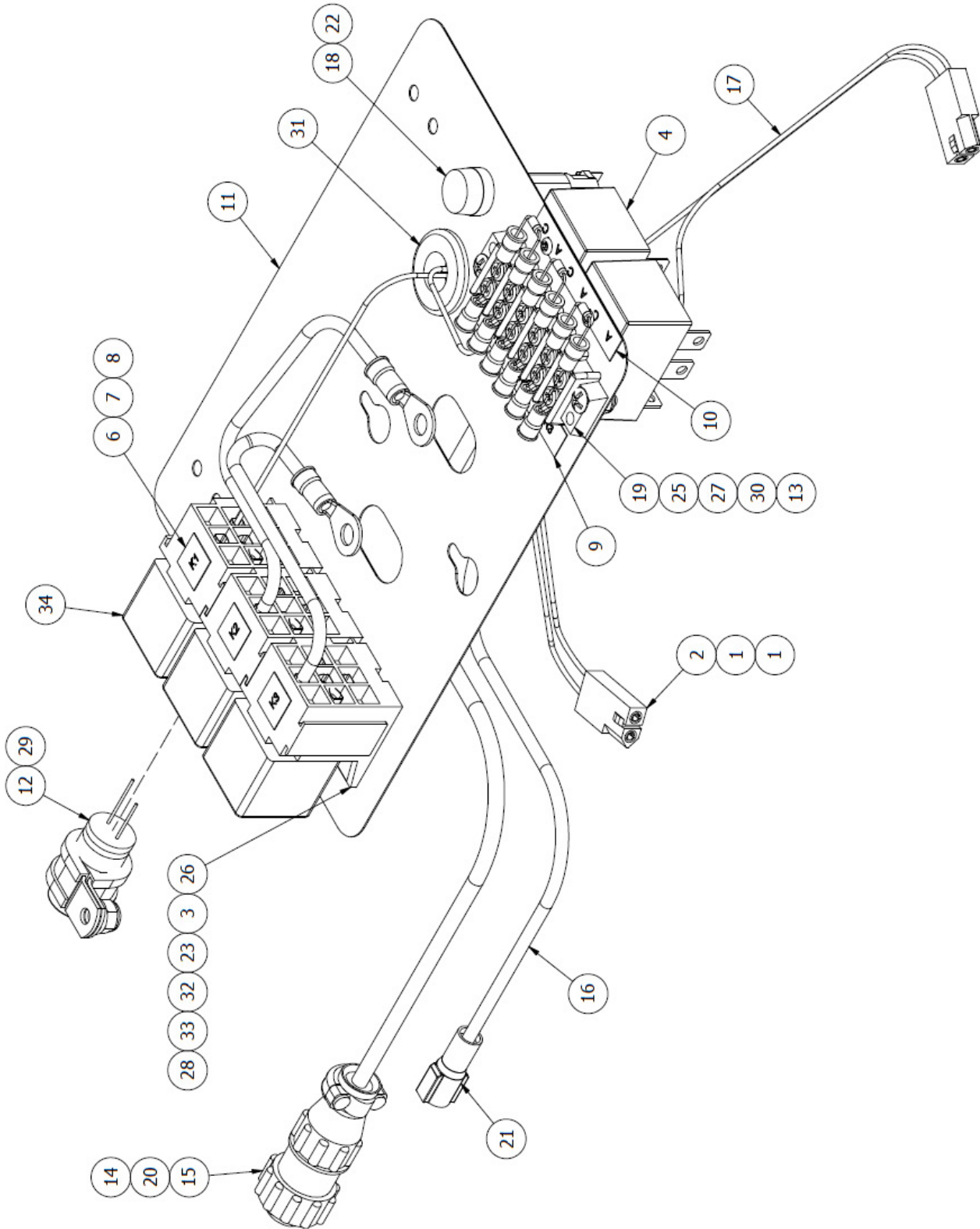

PARTS MANUAL  
3450 FLOATS ON CESSNA 206

ITEM	QTY	PART NO.	PART DESCRIPTION
-	1	1011449	ASSEMBLY, SUPPORT PLATE, HYDRAULIC PUMP, 12V
-	1	1011547	ASSEMBLY, SUPPORT PLATE, HYDRAULIC PUMP, 24V
1	4	02-09-1104	PIN, CRIMP FEMALE, 1/8" DIA
2	2	03-09-1022	CONNECTOR PLUG, MALE, 2 CONN.
3	14	1-901-355-917	TERMINAL
4 (12V)	1	1005042	TIMER RELAY HARNESS
4 (24V)	1	1005043	TIMER RELAY HARNESS
6	1	1009143-01	PLACARD, K1 INDICATOR
7	1	1009143-02	PLACARD, K2 INDICATOR
8	1	1009143-03	PLACARD, K3 INDICATOR
9	1	1009144-01	PLACARD, CR INDICATOR
10	1	1009144-02	PLACARD, AC INDICATOR
11	1	1011448	TOP PLATE, HYDRAULIC PUMP
12	1	1011798	ASSEMBLY, CAPACITOR
13	3	1N4004	DIODE, 2-1/2"
14	2	206062-3	CLAMP, CABLE, CPC SIZE 11
15	1	206429-1	PLUG, MAL, CPC SIZE 1, 4 PIN
16	6 FT	22759-16-12-9	WIRE, 12 AWG, WHITE
17	10 FT	22759-16-20-9	WIRE, 20 AWG, WHITE
18	1	3453LF2A	FUSE HOLDER
19	1	6-140	TERMINAL BLOCK, 6 CONNECTOR
20	3	66103-4	PIN, CRIMP SOCKET, 24-20G
21	1	73M-250-32-NL	CONNECTOR, MALE, 10-12 AWG, FULLY INSULATED
22	1	AGC-1	FUSE, 250V, (S2565-1)
23	2	AN3-3A	BOLT, 10-32, 0.0625 GRIP, UNDRILLED, STEEL
24	1	AN3-5A	BOLT, 10-32, 0.25 GRIP, UNDRILLED, STEEL
25	2	AN526C632R8	SCREW, MACHINE, TRUSS HEAD
26	3	BR05-FW	SOCKET, 5 PRONG, PLASTIC
27	2	MS21044N06	NUT, LOCKING, REGULAR HEIGHT, 6-32 UNC
28	3	MS21044N3	NUT, LOCKING, REGULAR HEIGHT, 10-32 UNF
29	1	MS21919WDG10	CLAMP, LOOP, CUSHIONED, 5/8 TUBE OD
30	12	MS25036-102	RING TERMINAL, #6 STUD, 16-22 AWG, RED
31	1	MS35489-14	GROMMET, RUBBER
32	3	NAS1149F0332P	WASHER, 0.203 ID, 0.032 THK, STEEL
33	3	NAS1149F0363P	WASHER, 0.203 ID, 0.063 THK, STEEL
34 (12V)	3	V23234- A0001-X032	RELAY, 12V, 5 PRONG
34 (24V)	3	0-332-209-211	RELAY, 24V, 5 PRONG

# HYDRAULIC PUMP ASSEMBLY PRE SERVICE LETTER 221

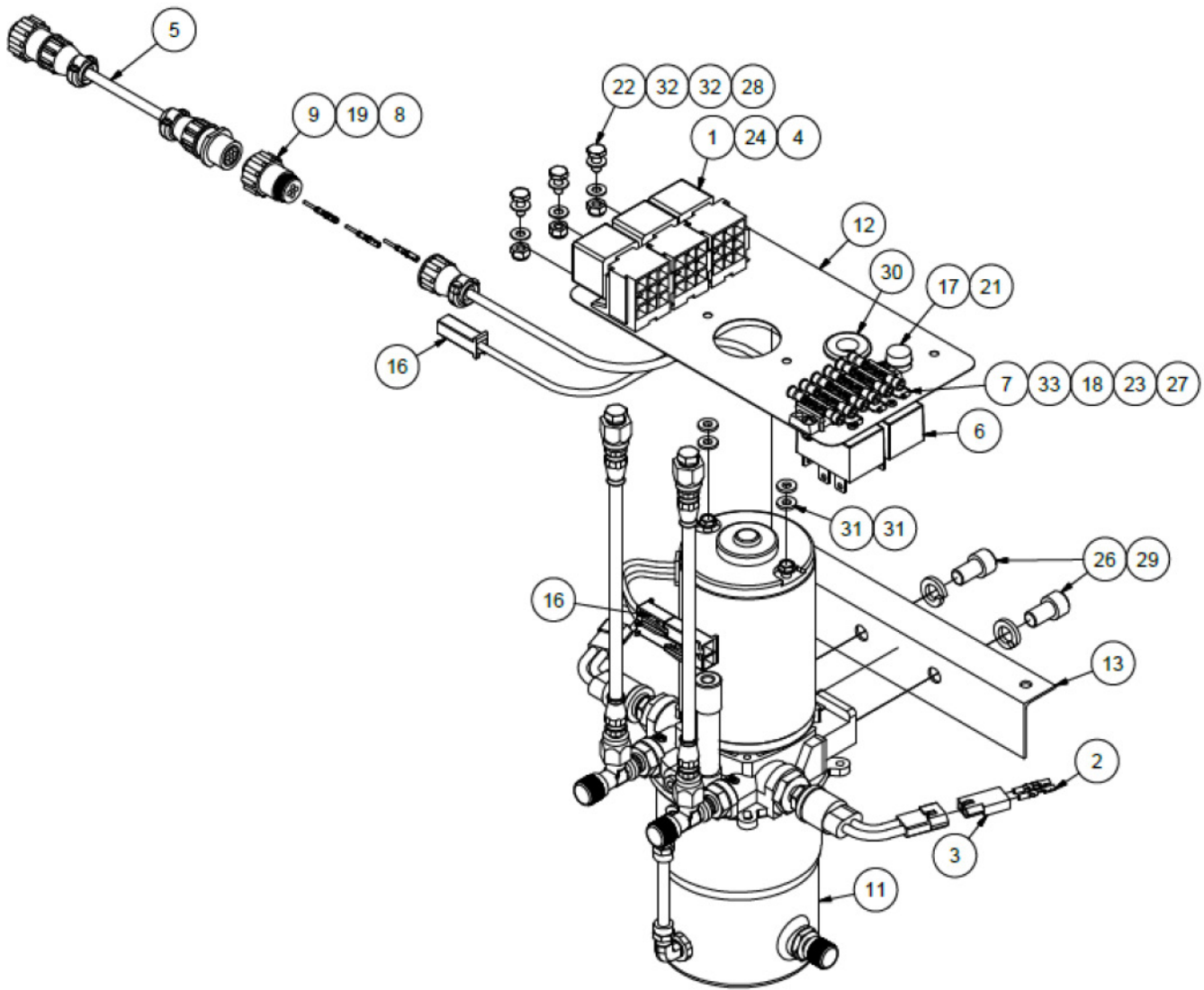



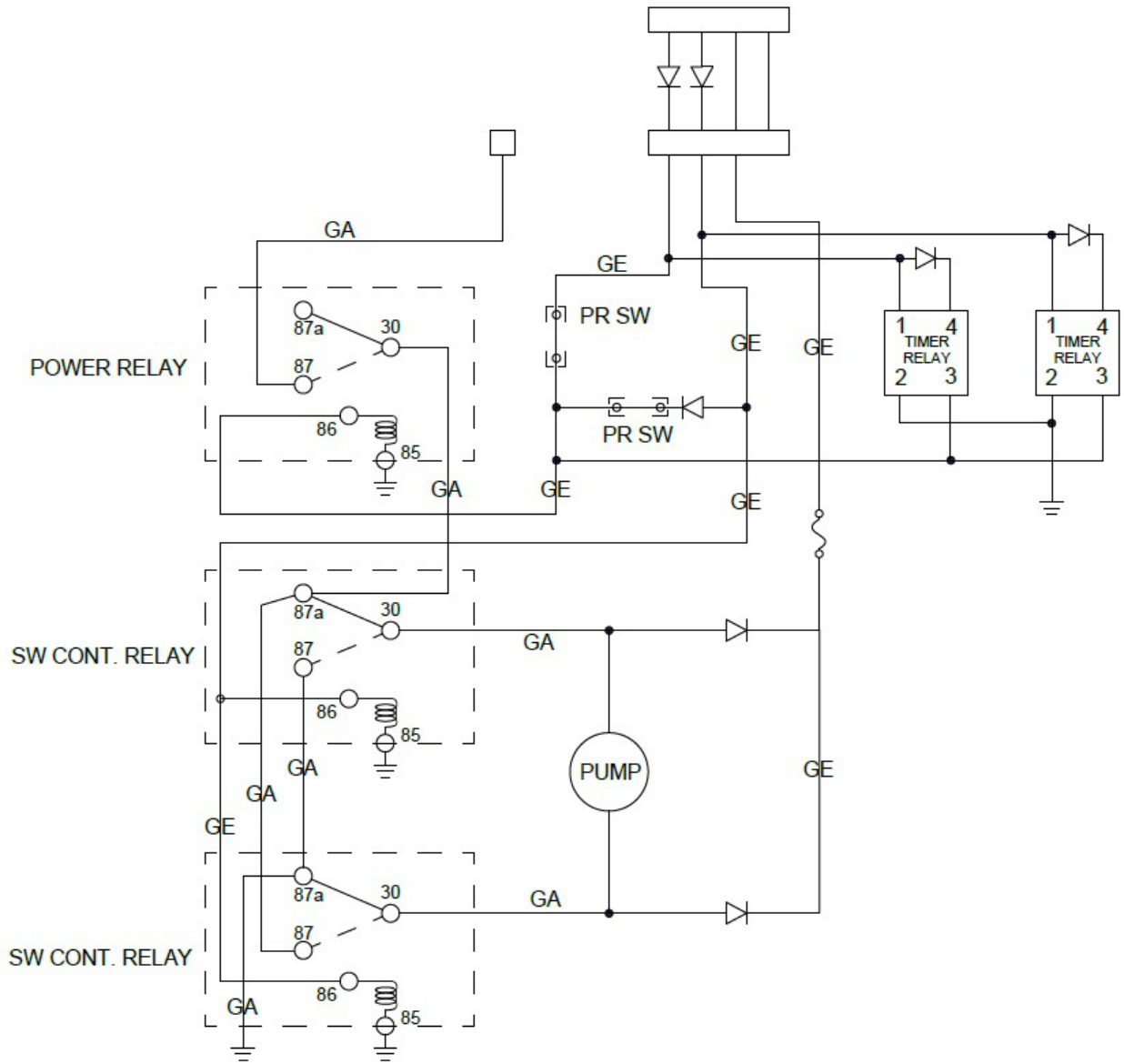

**ELECTRICAL SCHEMATIC**  
 PUMP WIRING SCHEMATIC  
 (RELAYS SHOWN IN RELAXED CONDITION)  
 1. GE WIRES 20 GA  
 2. GA WIRES 12 GA

ITEM	QTY	PART NO.	PART DESCRIPTION
1	3	0-332-209-137	RELAY, 12V, 5 PRONG
	3	0-332-209-211	RELAY, 24V, 5 PRONG
2	4	02-09-1104	PIN, CRIMP FEMALE, 1/8" DIA
3	2	03-09-1022	CONNECTOR PLUG, MALE, 2 CONN.
4	14	1-901-355-917	TERMINAL
5	1	1004949	CABLE, DIODE ADAPTOR
6	1	1005042	TIMER RELAY HARNESS, 12V
	1	1005043	TIMER RELAY HARNESS, 24V
7	3	1N4004	DIODE, 2-1/2"
8	2	206062-3	CLAMP, CABLE, CPC SIZE 11
9	1	206429-1	PLUG, MALE, CPC SIZE 1, 4 PIN
10	1	206430-2	CPC FREE HANG, 4 PIN, FEMALE
11	1	21A09000-215	ASSEMBLY, HYDRAULIC PUMP, 12V
	1	21A09000-282	ASSEMBLY, HYDRAULIC PUMP, 24V
12	1	21A09010-013	PLATE, SUPPORT, HYDRAULIC PUMP
13	1	21A09352-030	ANGLE, MOUNTING, HYD. PUMP
14	.5 FT	22759-16-12-9	WIRE, 12 AWG, WHITE
15	10.2 FT	22759-16-20-9	WIRE, 20 AWG, WHITE
16	1	73F-250-32NL	CONNECTOR, FEMALE, 10-12 AWG
	1	73M-250-32-NL	CONNECTOR, MALE, 10-12 AWG
17	1	3453LF2A	FUSE HOLDER
18	1	6-140	TERMINAL BLOCK, 6 CONNECTOR
19	3	66103-4	PIN, CRIMP SOCKET, 24-20G
20	3	66105-4	CRIMP SOCKET, FEMALE
21	1	AGC-1	FUSE, 250V, (S2565-1)
22	3	AN3-3A	BOLT
23	2	AN526-632R8	SCREW, MACHINE, TRUSS HEAD
24	3	BR05FW	SOCKET, 5 PRONG, PLASTIC
25	1.5 FT	HS105-3/16-0	HEAT SHRINK, TUBING, BLACK
26	2	MS16997-96	SOCKET HEAD CAP SCREW
27	2	MS21044N06	NUT
28	3	MS21044N3	NUT
29	2	MS35338-46	WASHER, SPLIT
30	1	MS35489-14	GROMMET, RUBBER
31	4	NAS1149D0363J	WASHER
32	6	NAS1149F0332P	WASHER
33	12	R-3	RING CONNECTOR

## HYDRAULIC PUMP FIREWALL (SOLOY ONLY) INSTALLATION POST SERVICE LETTER 242

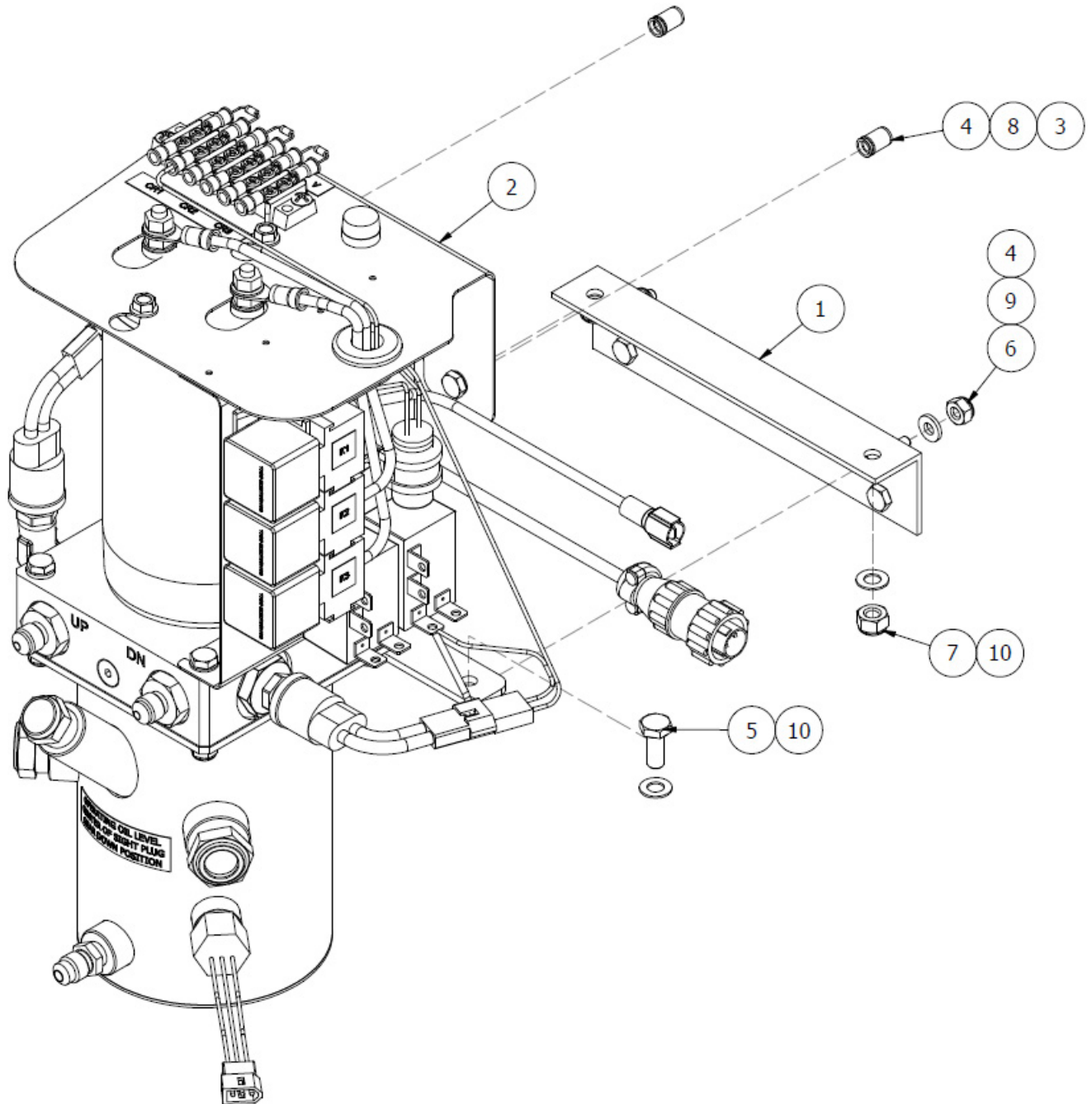

ITEM	QTY	PART NO.	PART DESCRIPTION
1	1	1009226	ANGLE, MOUNT, FIREWALL, HYDRAULIC PUMP
2	1	1011945	ASSEMBLY, HYDRAULIC POWER PACK, 24V
3	2	AKS4-1032	THREADED INSERT, 0.020-0.130 GRIP, 10-32 UNF
4	6	AN3-4A	BOLT, 10-32, 0.125 GRIP, UNDRILLED, STEEL
5	2	AN4-5A	BOLT, 1/4-28, 0.1875 GRIP, UNDRILLED, STEEL
6	4	MS21044N3	NUT, LOCKING, REGULAR HEIGHT, 10-32 UNF
7	2	MS21044N4	NUT, LOCKING, REGULAR HEIGHT, 1/4-28 UNF
8	2	MS35333-39	STAR WASHER
9	4	NAS1149F0363P	WASHER, 0.203 ID, 0.063 THK, STEEL
10	4	NAS1149F0432P	WASHER, 0.265 ID, 0.032 THK, STEEL

## HYDRAULIC PUMP FIREWALL (SOLOY ONLY) ASSEMBLY POST SERVICE LETTER 242

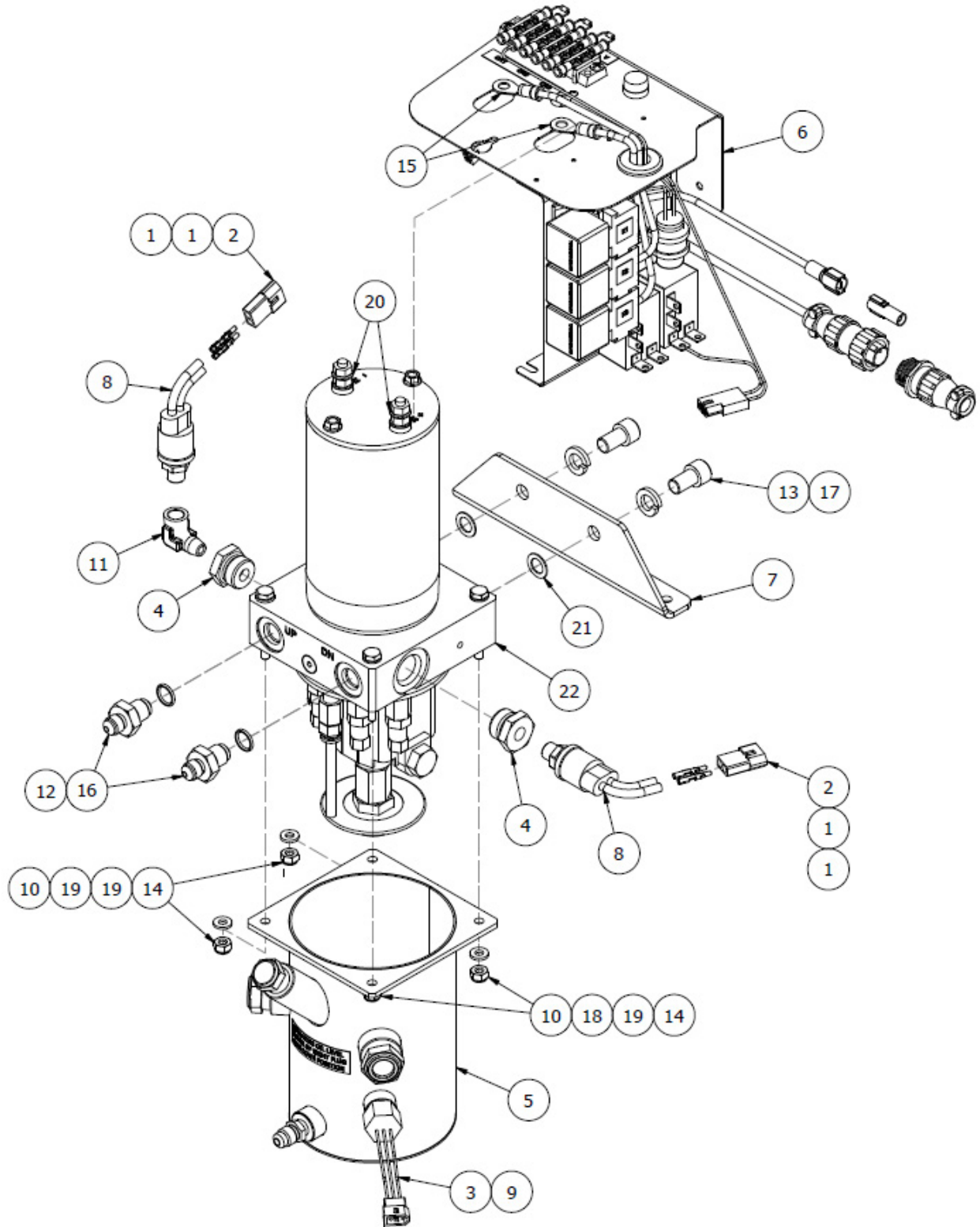

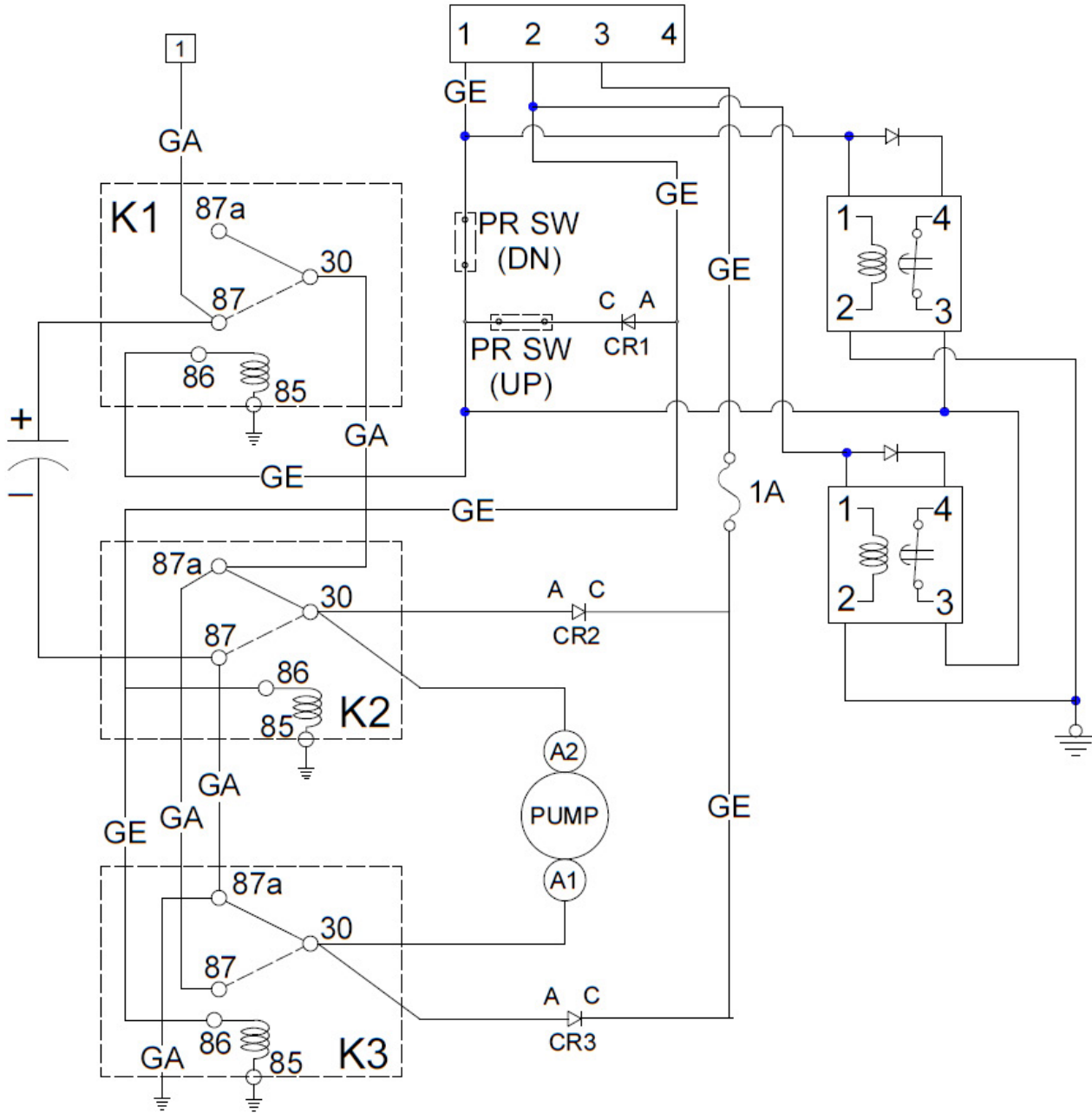

POWER PACK SCHEMATIC  
(RELAYS SHOWN IN RELAXED CONDITION)  
1. GE WIRES 20 GA  
2. GA WIRES 12 GA

PARTS MANUAL  
3450 FLOATS ON CESSNA 206

ITEM	QTY	PART NO.	PART DESCRIPTION
-	1	1011945	ASSEMBLY, HYDRAULIC POWER PACK, 24V
1	4	02-09-2118	PIN, CRIMP MALE, 1/8" DIA
2	2	03-09-2022	CONNECTOR PLUG, FEMALE
3	1	1009428	ASSEMBLY, SENSOR, FLUID LEVEL
4	2	1011062	ASSEMBLY, PLUG, PRESSURE SWITCH PORT
5	1	1011847	ASSEMBLY, HYDRAULIC RESERVOIR
6	1	1011943	ASSEMBLY, SUPPORT PLATE, HYDRAULIC PUMP
7	1	1011944	ANGLE, MOUNT, HYDRAULI PUMP
8	2	20PS001EB 700W500W	PRESSURE SWITCH
9	1	93786A200	PRESSURE-SEALING WASHER, M12
10	4	AN3-16A	BOLT, 10-32, 1.375 GRIP, UNDRILLED, STEEL
11	1	AN914-1D	ELBOW, 90 DEGREE, INTERNAL EXTERNAL PIPE
12	2	AN919-3D	FITTING, REDUCER
13	2	MS16997-96	SOCKET HEAD CAP SCREW
14	4	MS21044N3	NUT, LOCKING, REGULAR HEIGHT, 10-32 UNF
15	2	MS25036-157	RING TERMINAL, 1/4 STUD, 10-12 AWG, YELLOW
16	2	MS28775-013	"O" RING, HYDRAULIC
17	2	MS35338-46	WASHER, SPLIT
18	2	NAS1149F0332P	WASHER, 0.203 ID, 0.032 THK, STEEL
19	6	NAS1149F0363P	WASHER, 0.203 ID, 0.063 THK, STEEL
20	2	NAS1149F0432P	WASHER, 0.265 ID, 0.032 THK, STEEL
21	2	NAS1149F0632P	WASHER, 0.39 ID, 0.032 THK, STEEL
22	1	YBZS- C0.63W2T100K/ UVZOT2	HYDRAULIC POWER PACK, 24VDC, .64 PUMP

# ASSEMBLY SUPPORT PLATE FIREWALL (SOLOY ONLY)

## POST SERVICE LETTER 242

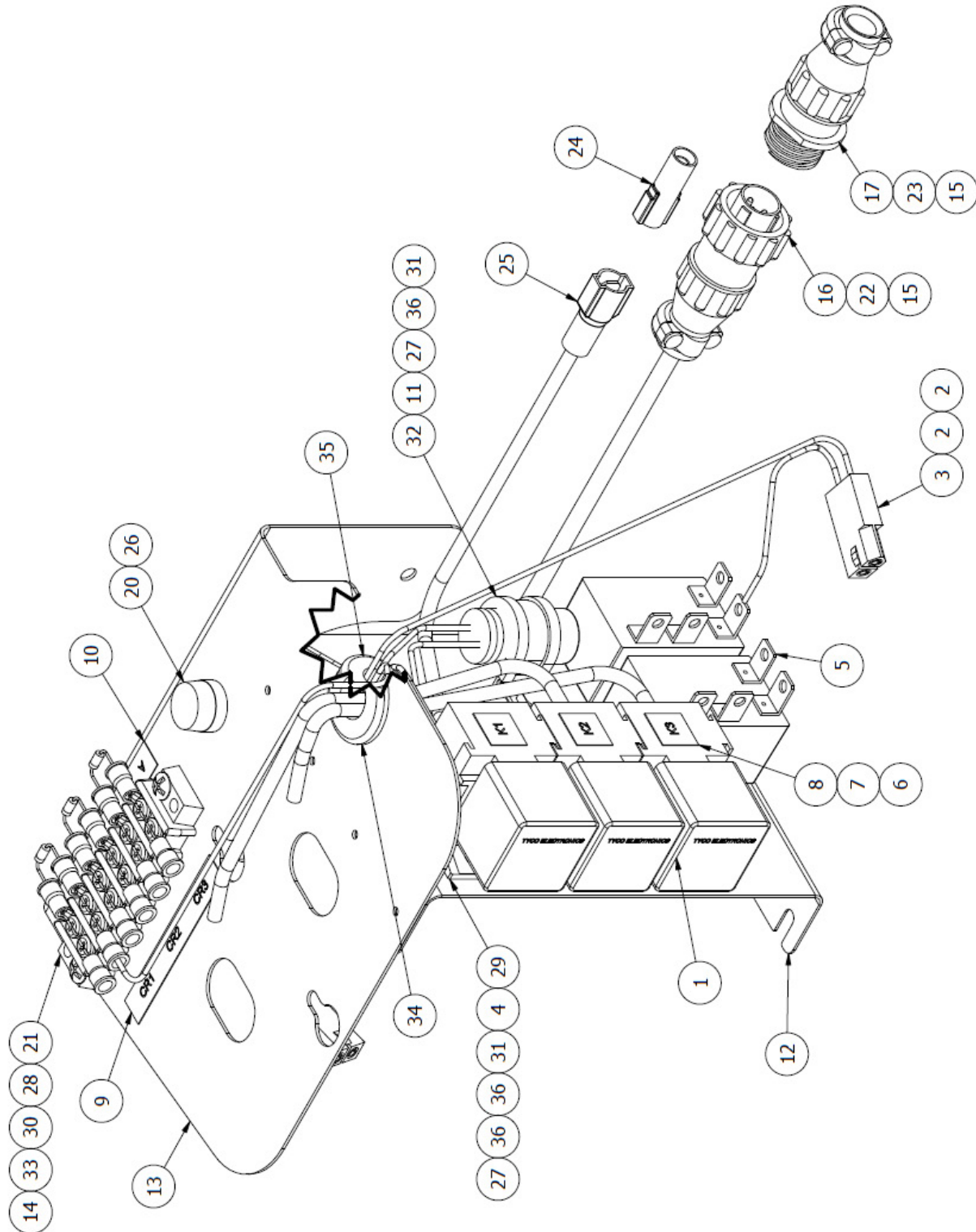



PARTS MANUAL  
3450 FLOATS ON CESSNA 206

ITEM	QTY	PART NO.	PART DESCRIPTION
-	1	1011943	ASSEMBLY, SUPPORT PLATE, HYDRAULIC POWER PACK
1	3	0-332-209-211	RELAY, 24V, 5 PRONG
2	4	02-09-1104	PIN, CRIMP FEMALE, 1/8" DIA
3	2	03-09-1022	CONNECTOR PLUG, MALE, 2 CONN.
4	14	1-901-355-917	TERMINAL
5	1	1005043	TIMER RELAY HARNESS
6	1	1009143-01	PLACARD, K1 INDICATOR
7	1	1009143-02	PLACARD, K2 INDICATOR
8	1	1009143-03	PLACARD, K3 INDICATOR
9	1	1009144-01	PLACARD, CR INDICATOR
10	1	1009144-02	PLACARD, AC INDICATOR
11	1	1011798	ASSEMBLY, CAPACITOR
12	1	1011844	ELECTRONIC SIDE PLATE
13	1	1011940	TOP PLATE, HYDRAULIC PUMP
14	3	1N4004	DIODE, 2-1/2"
15	2	206062-3	CLAMP, CABLE, CPC SIZE 11
16	1	206429-1	PLUG, MAL, CPC SIZE 1, 4 PIN
17	1	206430-2	CPC FREE HANG, 4 PIN, FEMALE
18	6 FT	22759-16-12-9	WIRE, 12 AWG, WHITE
19	10.1 FT	22759-16-20-9	WIRE, 20 AWG, WHITE
20	1	3453LF2A	FUSE HOLDER
21	1	6-140	TERMINAL BLOCK, 6 CONNECTOR
22	3	66103-4	PIN, CRIMP SOCKET, 24-20G
23	3	66105-4	CRIMP SOCKET, FEMALE
24	1	73F-250-32-NL	CONNECTOR, FEMALE, 10-12 AWG, FULLY INSULATED
25	1	73M-250-32-NL	CONNECTOR, MALE, 10-12 AWG, FULLY INSULATED
26	1	AGC-1	FUSE, 250V, (S2565-1)
27	4	AN3-3A	BOLT, 10-32, 0.0625 GRIP, UNDRILLED, STEEL
28	2	AN526C632R8	SCREW, MACHINE, TRUSS HEAD
29	3	BR05-FW	SOCKET, 5 PRONG, PLASTIC
30	2	MS21044N06	NUT, LOCKING, REGULAR HEIGHT, 6-32 UNC
31	4	MS21044N3	NUT, LOCKING, REGULAR HEIGHT, 10-32 UNF
32	1	MS21919WDG10	CLAMP, LOOP, CUSHIONED, 5/8 TUBE OD
33	12	MS25036-102	RING TERMINAL, #6 STUD, 16-22 AWG, RED
34	1	MS35489-14	GROMMET, RUBBER, 5/16 HOLE, 11/16 GROOVE DIA, .062 PANEL
35	1	MS35489-9	GROMMET, RUBBER, 5/16 HOLE, 9/16 GROOVE DIA, .062 PANEL
36	7	NAS1149F0332P	WASHER, 0.203 ID, 0.032 THK, STEEL

### HYDRAULIC PUMP OVERVIEW POST SERVICE LETTER 221

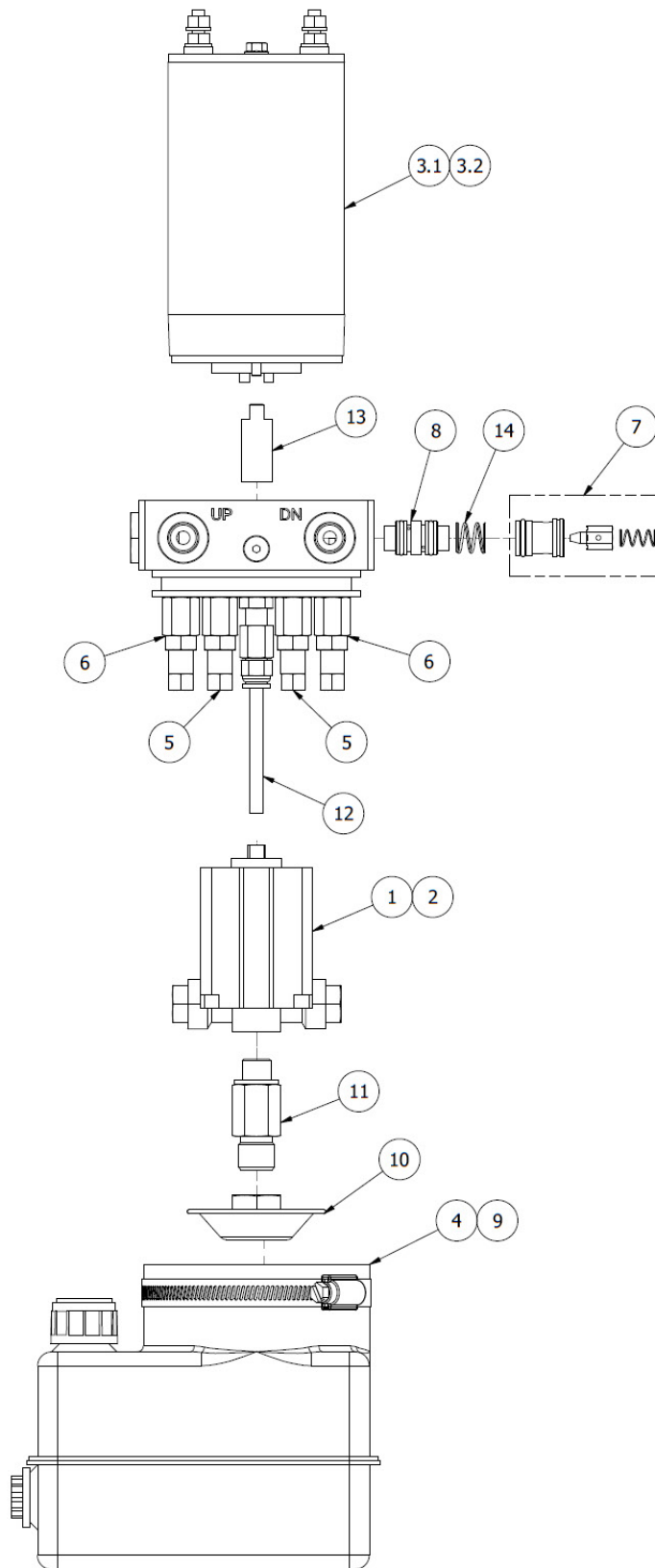

PARTS MANUAL  
3450 FLOATS ON CESSNA 206

ITEM	QTY	PART NO.	PART DESCRIPTION
1	1	202-0003	BI-DIRECTIONAL PUMP, 0.64 ML/R
2	1	299-0008	SEAL KIT, BI-DIRECTIONAL GEAR PUMP
3.1	1	610-0010	DC MOTOR, 12V, .8KW
3.2	1	610-0017	DC MOTOR, 24V, .8 KW
4	1	622-0016	RESERVOIR, 1 QT.
5	2	631-0005	PRESSURE RELIEF VALVE
6	2	631-0006	THERMAL RELIEF VALVE
7	2	632-0004	ASSEMBLY, PILOT OPERATED CHECK VALVE
8	1	637-0024	SHUTTLE VALVE
9	1	681-0050	CLAMP, HOSE, 1 LITER PLASTIC RESERVOIR
10	1	682-0019	FILTER, PICKUP TUBE, HYDRAULIC PUMP
11	1	682-0055	SUCTION HEX TUBE
12	1	682-0056	RETURN TUBE
13	1	683-0011	COUPLING, MOTOR TO PUMP
14	2	685-0012	SPRING, SHUTTLE VALVE
15	1	687-0001	SEAL KIT, RESERVIOR O-RING, PILOT OPERATED RELIEF VALVE O-RING, THERMAL AND PRESSURE RELIEF VALVE O-RING (NOT SHOWN)

### HYDRAULIC PUMP OVERVIEW PRE SERVICE LETTER 221

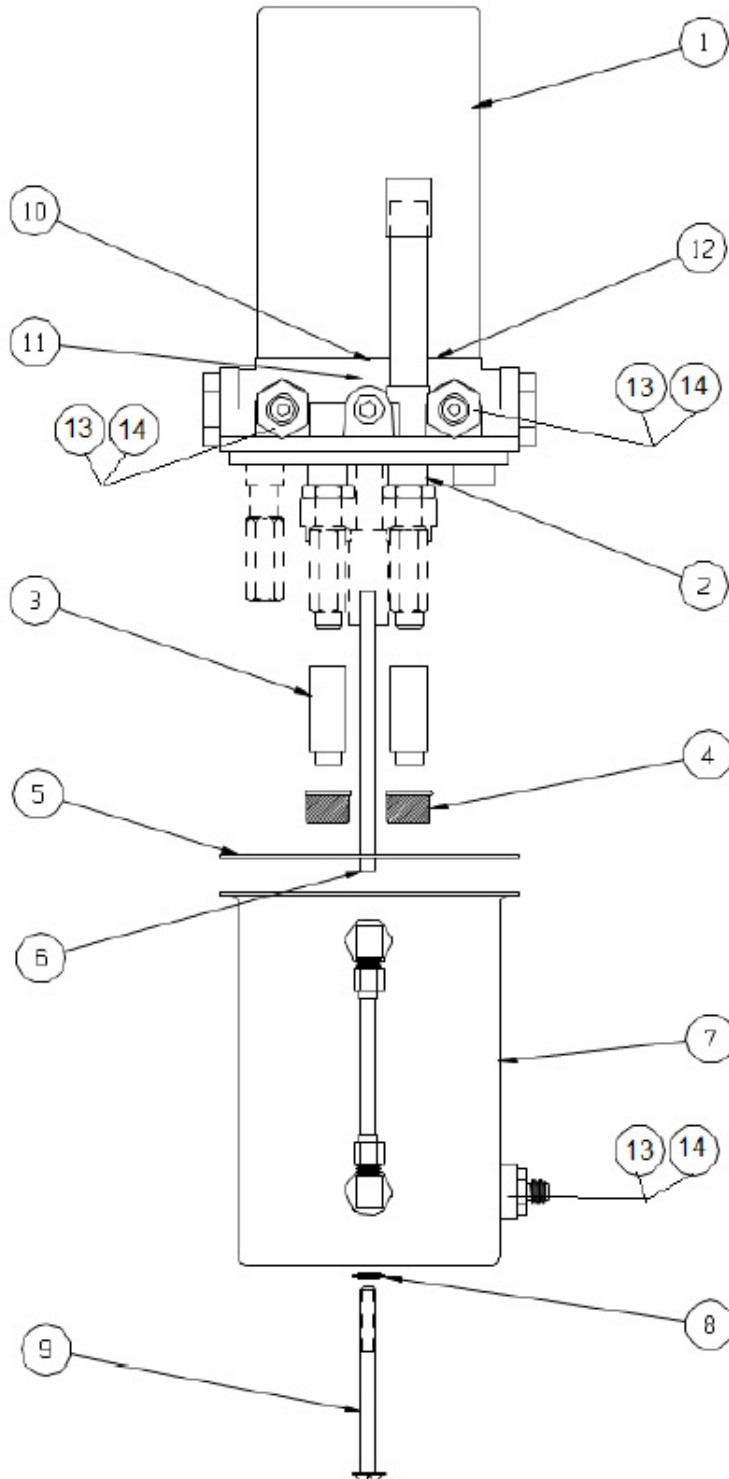

PARTS MANUAL  
3450 FLOATS ON CESSNA 206

ITEM	QTY	PART NO.	PART DESCRIPTION
1	1	21A09000-215	HYDRAULIC PUMP ASS'Y (12V)
	1	21A09000-282	HYDRAULIC PUMP ASS'Y (24V)
	1	640661	MOTOR (12V)
	1	641131	MOTOR (24V)
2	1	634873	BASIC PUMP
3	2	362136	TUBE EXTENSIONS
4	2	410521*	FILTER
5	1	410578*	SEAL RESERVIOR
6	1	365047	RETURN TUBE
7	1	775260	RESERVIOR – GAUGE ASS'Y
8	1	415067	SEAL THREAD
9	1	409715*	SCREW – RESERVIOR ATTACH
10	1	361183*	COUPLING – MOTOR TO PUMP
11	1	410512	SEAL – PUMP SHAFT
12	1	405673	“O” RING MOTOR TO BASE
13	3	AN815-4D	UNION
14	3	MS28775-012	O RING, HYDRAULIC PACKING 0.364 ID

\* Reference Wipaire drawing 1011065 for alternate part numbers.

### HYDRAULIC PUMP SCHEMATIC

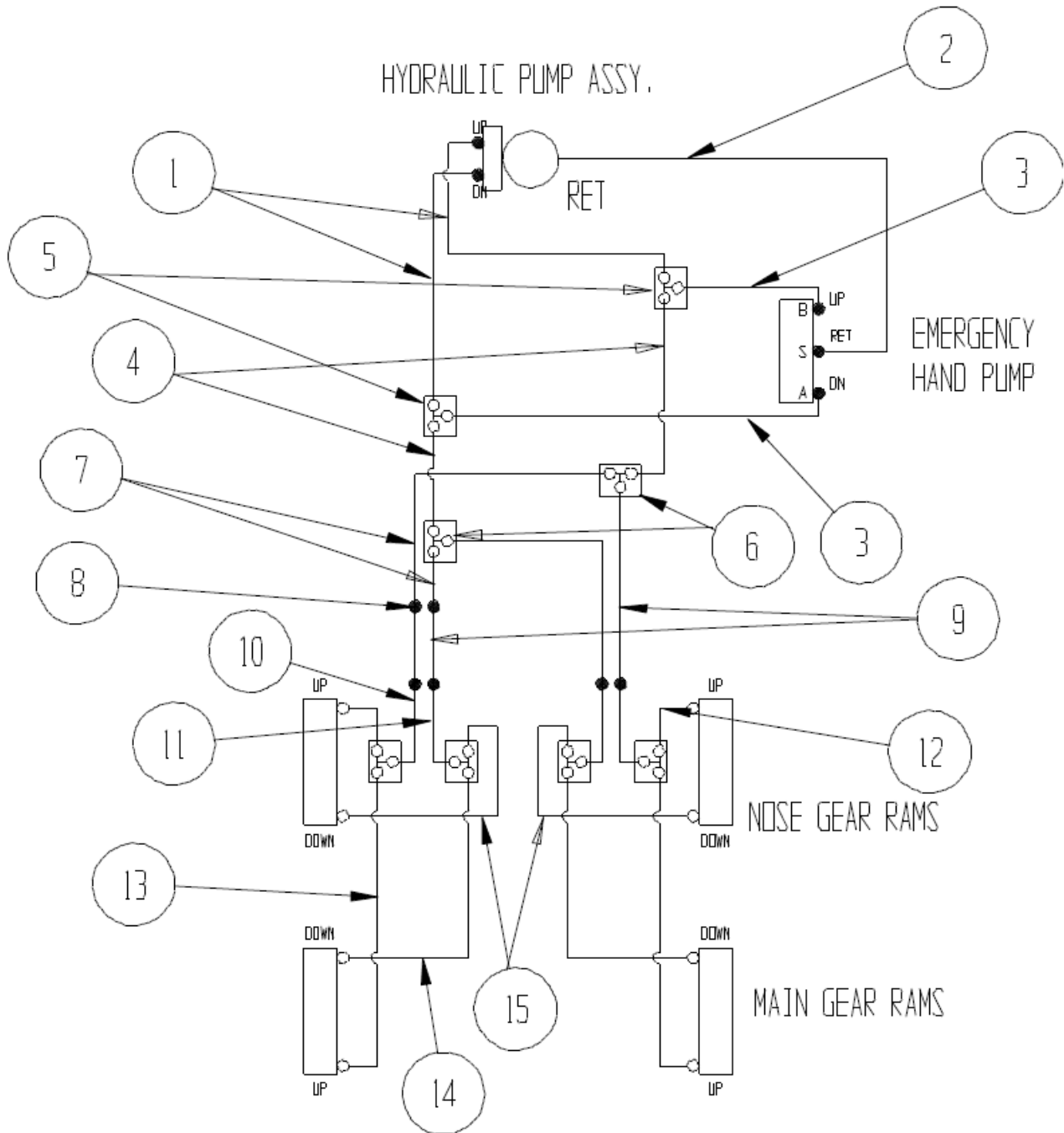

PARTS MANUAL  
3450 FLOATS ON CESSNA 206

ITEM	QTY	PART NO.	PART DESCRIPTION
1	2	34A09000-256	ASS'Y – HYDRAULIC HOSE
2	1	34A09000-257	ASS'Y – HYDRAULIC HOSE
3	2	34A09000-258	ASS'Y – HYDRAULIC HOSE
4	1	21A09000-218	ASS'Y HYDRAULIC HOSE
5	2	AN824-4D	“T” FITTING
6	2	AN804-4D	“T” FITTING
	2	AN924-4D	NUT
	2	NAS1149F0763P	WASHER
7	2	34A09000-259	ASS'Y HYDRAULIC HOSE
8	2	AN833-4D	ELBOW
	2	AN924-4D	NUT
	2	NAS1149F0763P	WASHER
9	4	21A04000-080	ASS'Y – HYDRAULIC HOSE
10	2	30A09000-272	ASS'Y – HYDRAULIC HOSE
11	2	30A09000-273	ASS'Y – HYDRAULIC HOSE
12	2	30A09000-268	ASS'Y – HYDRAULIC HOSE
13	2	34A09000-274	ASS'Y – HYDRAULIC HOSE
14	2	34A09000-275	ASS'Y – HYDRAULIC HOSE
15	2	30A09000-269	ASS'Y – HYDRAULIC HOSE

THIS PAGE INTENTIONALLY LEFT BLANK



# SECTION 11

## ELECTRICAL

### CONTENTS

ELECTRICAL SCHEMATIC POST SERVICE LETTER 221 .....	142
ELECTRICAL SCHEMATIC PRE SERVICE LETTER 221 .....	144
GEAR CONTROL (ROUND).....	146
GEAR CONTROL (RECTANGLE).....	148
GEAR CONTROL (RECTANGLE) (G1000 ONLY) .....	150

# ELECTRICAL SCHEMATIC POST SERVICE LETTER 221

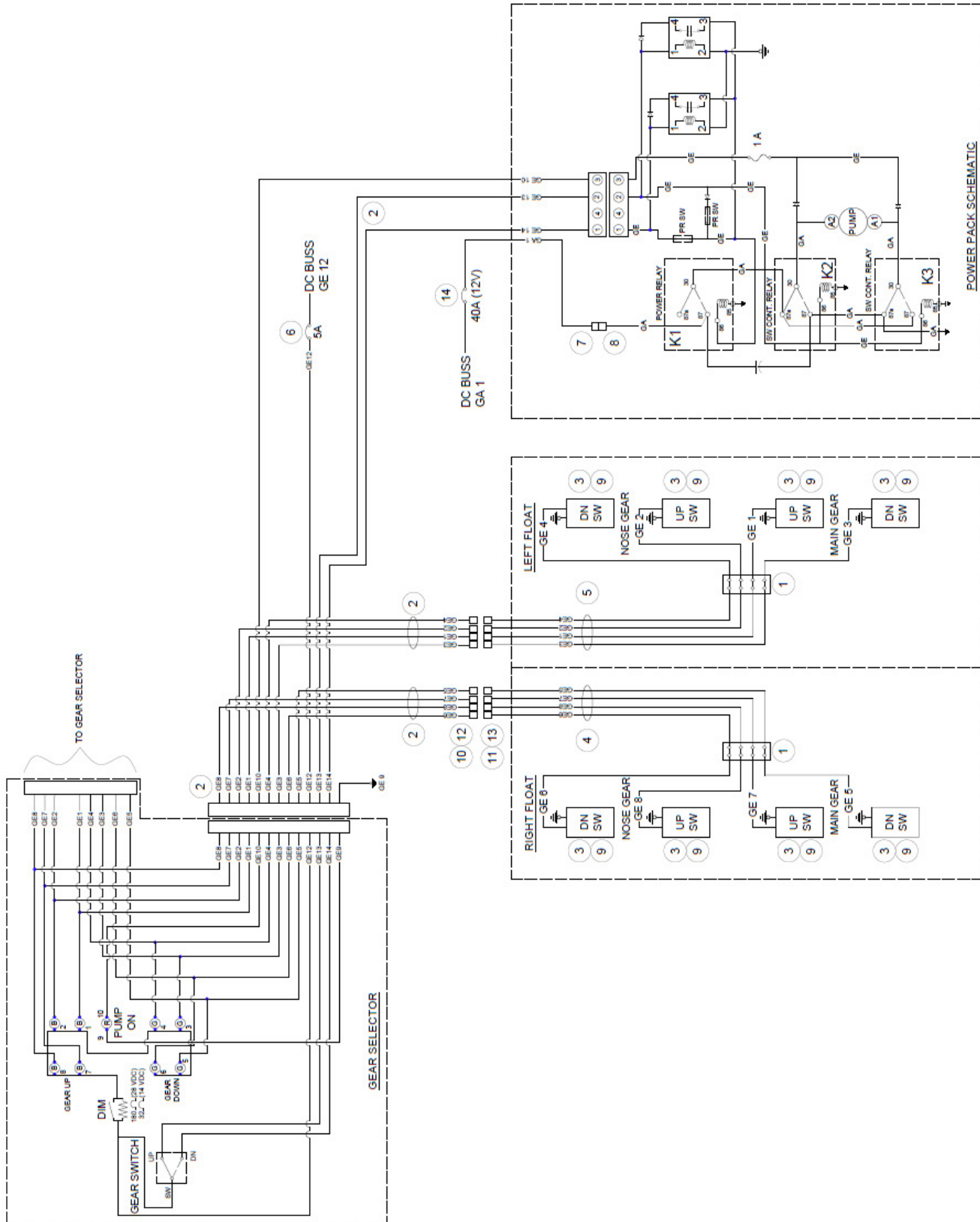

PARTS MANUAL  
3450 FLOATS ON CESSNA 206

ITEM	QTY	PART NO.	PART DESCRIPTION
1	4	1005724	GEAR POSITION SWITCH, PROXIMITY, 3 WIRE
2	4	1006668	ELECTRIC WATER RUDDER RETRACT SOLENOID
3	2	4-140	TERMINAL BLOCK, 4 POSITION
4	1	4A11000-012	WIRE HARNESS, GEAR SELECTOR, FLOATS, HYD. PUMP
5	8	5801	GEAR POSITION SWITCH, PROXIMITY, MAGNETIC
6	2	6-140	TERMINAL BLOCK, 6 POSITION
7	1	6A10000-004	WIRE HARNESS, LEFT FLOAT
8	1	6A10000-005	WIRE HARNESS, RIGHT FLOAT
9	1	7277-2-5	CIRCUIT BREAKER, 5 AMP
10	1	73F-250-32-NL	CONNECTOR, FEMALE, 12-10 AWG
11	1	73M-250-32-NL	CONNECTOR, MALE, 12-10 AWG
12	8	21A09005-262	CLIP, GEAR POSITION SWITCH HOLDER
13	1	MS24523-21	TOGGLE SWITCH, ELECTRIC WATER RUDDER RETRACT
14	8	S1635-1	PIN
15	8	S1636-1	SOCKET
16	8	S1637-1	HOUSING
17	8	S1637-2	HOUSING
18	1	W23-X1A1G-25	CIRCUIT BREAKER, 25 AMP, 24VDC
19	1	W23-X1A1G-40	CIRCUIT BREAKER, 40 AMP, 12VDC

# ELECTRICAL SCHEMATIC PRE SERVICE LETTER 221

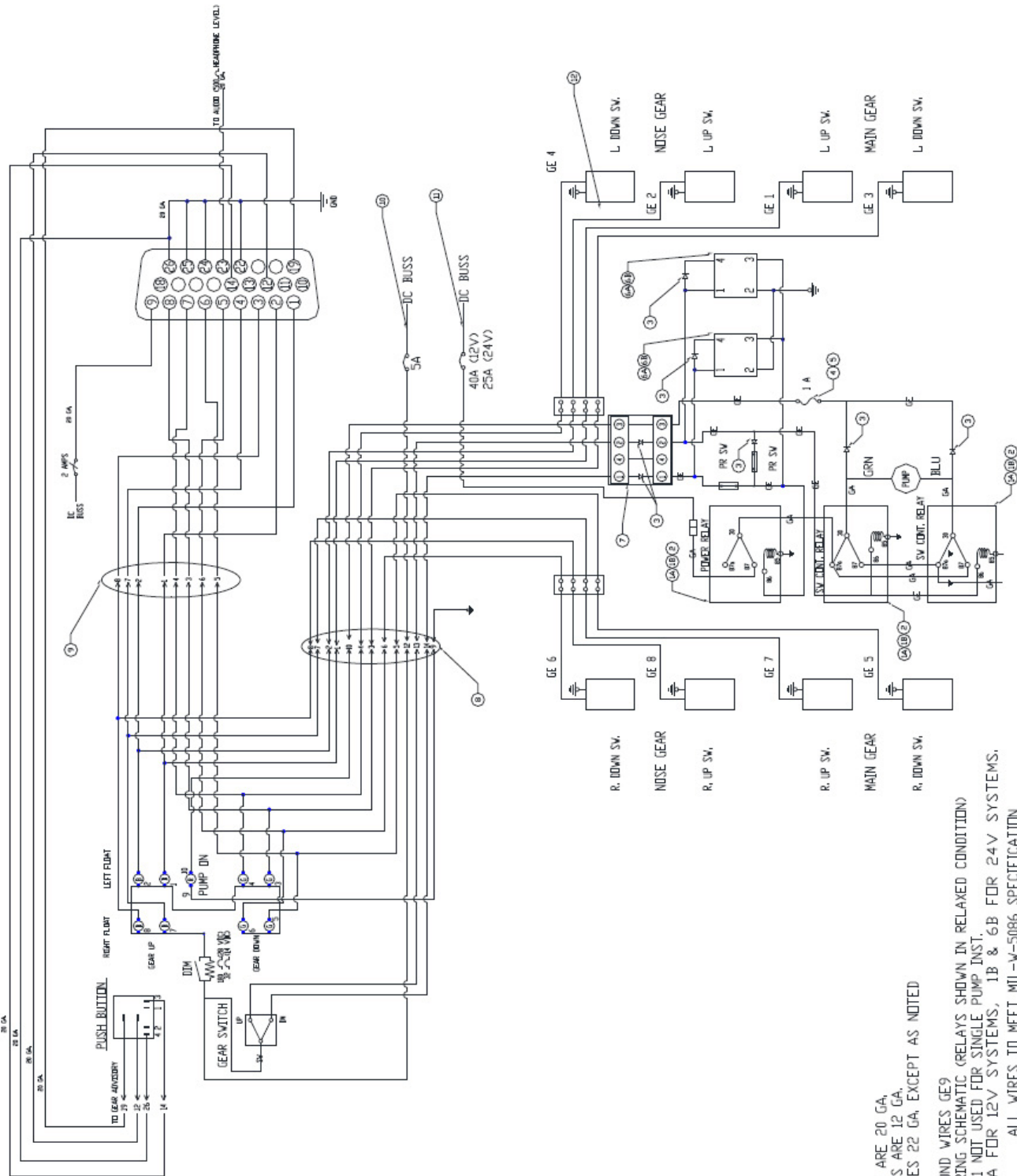

PARTS MANUAL  
3450 FLOATS ON CESSNA 206

ITEM	QTY	PART NO.	PART DESCRIPTION
1A	3	0-332-209-211	RELAY 12V
1B	3	0-332-209-137	RELAY 24V
2	3	BR05FW	RELAY SOCKET
3	7	1N4004	DIODE
4	1	AGC-1	FUSE 1 AMP
5	1	3453LF2A	FUSE HOLDER
6A	1	1005042	ASSEMBLY, TIMER RELAY 12V
6B	2	1005043	ASSEMBLY, TIMER RELAY 24V
7	1	1004949	DIODE CABLE ADAPTOR
8	1	4A11000-014	WIRE HARNESS
9	1	4A11000-012	WIRE HARNESS
10	1	5 AMP	CIRCUIT BREAKER
11	1	40 AMP	CIRCUIT BREAKER (12V)
	1	25 AMP	CIRCUIT BREAKER (24V)
12	8	5801	SWITCH – PROXIMITY - MAGNETIC
	8	21A09005-262	CLIP – SWITCH HOLDER



PARTS MANUAL  
3450 FLOATS ON CESSNA 206

ITEM	QTY	PART NO.	PART DESCRIPTION
-	1	21A11000-009	GEAR SELECTOR ASSY. ROUND (12V)
-	1	21A11000-019	GEAR SELECTOR ASSY. ROUND (24V)
1	1	8857K44	SWITCH
2	1	A101SYCB	TOGGLE SWITCH, SPDT, ON-ON
3	9	515-0012	SOCKET
4	1	507-3914-1431-600	INDICATOR LAMP, 14V, RED
	1	507-3918-1431-600	INDICATOR LAMP, 28V, RED
5	4	507-3914-1432-600	INDICATOR LAMP, 14V, GREEN
	4	507-3918-1432-600	INDICATOR LAMP, 28V, GREEN
6	4	507-3914-1434-600	INDICATOR LAMP, 14V, BLUE
	4	507-3918-1434-600	INDICATOR LAMP, 28V, BLUE
7	1	21A11179-001	BLOCK, GEAR CONTROL
8	1	4A11000-008	HARNESS ASSEMBLY, GEAR SELECTOR
9	1	21A11259-003	GEAR SWITCH KNOB
10	1	RH-5-35	RESISTOR, 14V, DALE RH5 5W
	1	RH-5-180	RESISTOR, 28V, DALE RH5 5W
11	3	AN526-632R8	SCREW, TRUSS HEAD, 6-32
12	1	10B3-6202	PLACARD, ROUND2100 GEAR SELECTOR
13	3	R-3	RING CONNECTOR, #6, 20 AWG, RED
14	5	PLT1M-M	CABLE TIE
15	16 IN	HIXR-3/16	SHRINK WRAP, 3/16, WHITE
16	3 IN	HS105-1/2-0	HEAT SHRINK TUBING
17	6 IN	22759-16-20-9	WIRE, 20AWG, WHITE

## GEAR CONTROL (RECTANGLE)

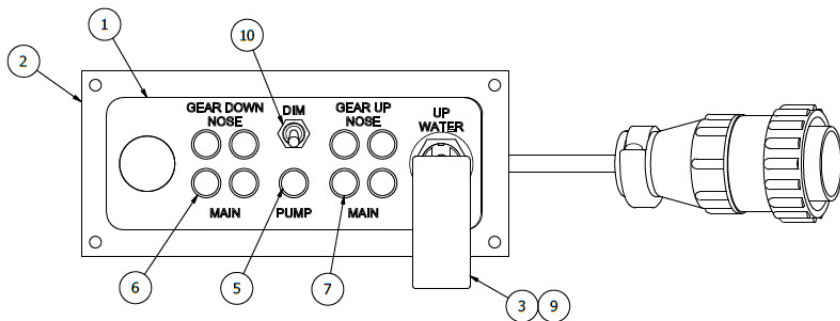
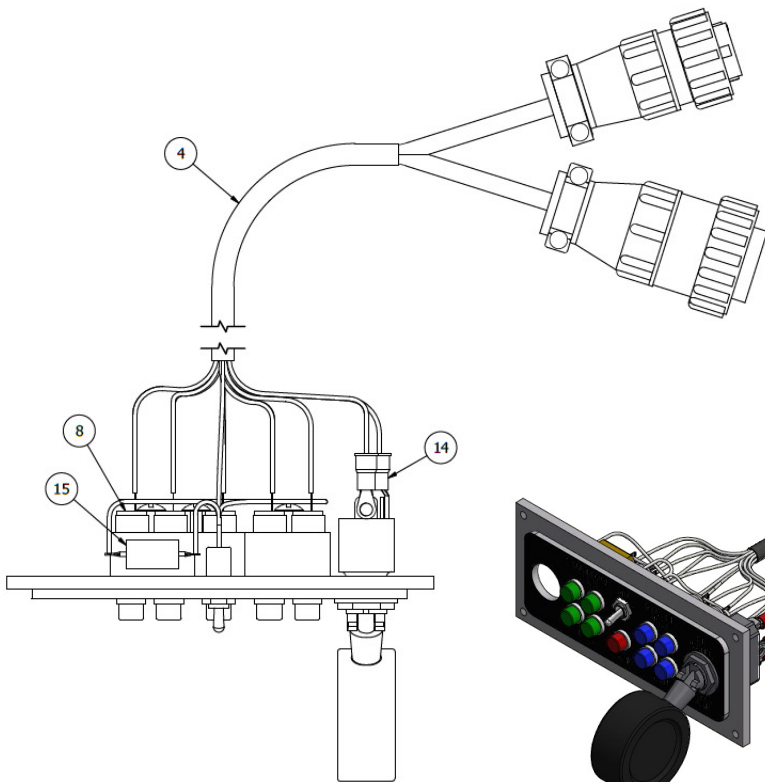
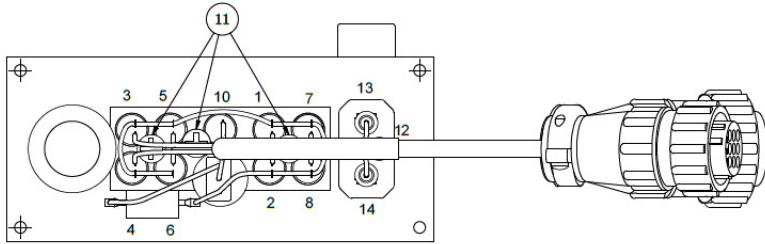



PARTS MANUAL  
3450 FLOATS ON CESSNA 206

ITEM	QTY	PART NO.	PART DESCRIPTION
-	1	21A11000-010	ASSEMBLY, INDICATOR, GEAR CONTROL, SQUARE, 12V
-	1	21A11000-018	ASSEMBLY, INDICATOR, GEAR CONTROL, SQUARE, 24V
1	1	10B3-6277	PLACARD, GEAR CONTROL SQUARE
2	1	21A11179-002	BLOCK GEAR CONTROL SQUARE
3	1	21A11259-003	GEAR SWITCH KNOB
4	1	4A11000-008	WIRING HARNESS ASSY. SELECTOR
5	1	5073914-1431-600	LAMP LIGHT, RED 14V
	1	5073918-1431-600	LAMP, LIGHT, RED, 28V
6	4	5073914-1432-600	LAMP LIGHT, GREEN 14V
	4	5073918-1432-600	LAMP, LIGHT, GREEN, 28V
7	4	5073914-1434-600	LAMP LIGHT, BLUE, 14V
	4	5073918-1434-600	LAMP, LIGHT, BLUE, 28V
8	9	515-0012	SOCKET
9	1	8857K44	SWITCH
10	1	A101SYCB	TOGGLE SWITCH
11	3	AN526C632R8	SCREW, TRUSS HEAD MACHINE, 6-32 THREAD, 1/2" LENGTH
12	12"	HS105-3/32-0	HEAT SHRINK, TUBING - BLACK
13	8	PLT1M-M	CABLE TIE, NYLON, WHITE, 4" (SMALL)
14	3	R-3	TERMINAL, RING #6 STUD, 16-22 AWG, RED
15	1	RH-5-35	RESISTOR, 14V, DALE RH5 5W
	1	RH-5-180	RESISTOR, 28V, DALE RH5 5W

### GEAR CONTROL (RECTANGLE) (G1000 ONLY)

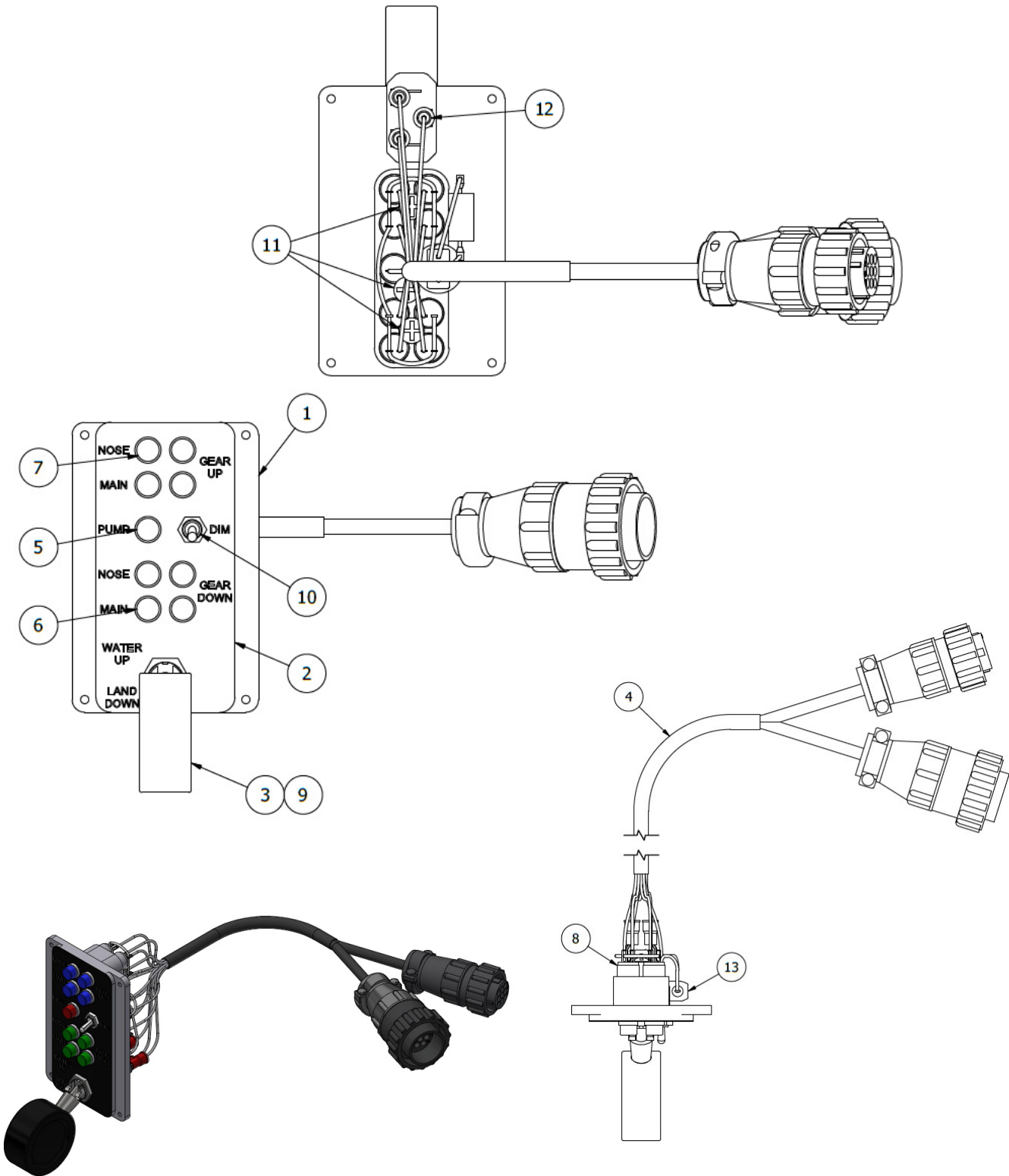

PARTS MANUAL  
3450 FLOATS ON CESSNA 206

ITEM	QTY	PART NO.	PART DESCRIPTION
-	1	1001431	ASSEMBLY, INDICATOR, GEAR CONTROL, G1000
1	1	1001172	BLOCK, GEAR CONTROL, GLASS PANEL
2	1	1001173	PLACARD, GEAR CONTROL, GLASS PANEL
3	1	21A11259-003	GEAR SWITCH KNOB
4	1	4A11000-008	ASSEMBLY, WIRE HARNESS
5	1	507-3918-1431-600	INDICATOR LAMP, 28V, RED
6	4	507-3918-1432-600	INDICATOR LAMP, 28V, GRN
7	4	507-3918-1434-600	INDICATOR LAMP, 28V, BLU
8	9	515-0012	SOCKET, GEAR SELECTOR LIGHTS
9	1	8857K44	SWITCH, GEAR SELECTOR, 2100/7000
10	1	A101SYCB	TOGGLE SWITCH, SPDT, ON
11	3	AN526-632R6	SCREW, MACHINE, TRUSS HEAD
12	3	MS25036-102	RING TERMINAL, #6 STUD, 16-22 AWG, RED
13	1	RH005180R0FE02	RESISTOR, 28V

THIS PAGE INTENTIONALLY LEFT BLANK

# SECTION 12

## VENTRAL FIN

### CONTENTS

VENTRAL FIN INSTALLATION .....	154
--------------------------------	-----

### VENTRAL FIN INSTALLATION

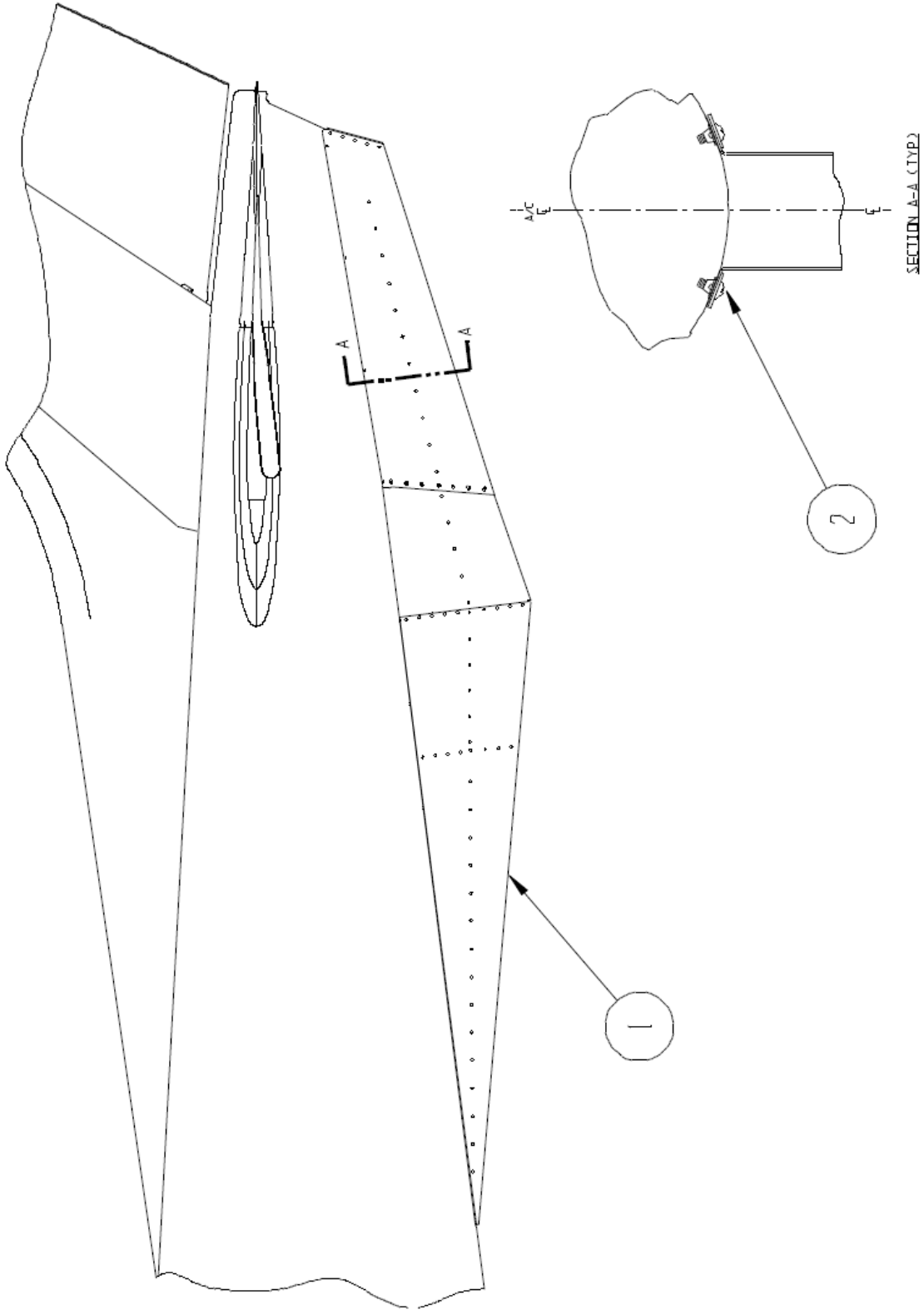

PARTS MANUAL  
3450 FLOATS ON CESSNA 206

<b>ITEM</b>	<b>QTY</b>	<b>PART NO.</b>	<b>PART DESCRIPTION</b>
1	1	4A12000-048	ASS'Y VENTRAL FIN
2	A/R	AN526-1032-R8	SCREW – ATTACH
	A/R	MS21078-3	NUT PLATE – ATTACH