



WIPLINE FLOATS • SKIS • MODIFICATIONS • AIRCRAFT SALES
AVIONICS • INTERIOR • MAINTENANCE • PAINT REFINISHING



**SERVICE MANUAL
AND
INSTRUCTIONS FOR
CONTINUED AIRWORTHINESS
FOR THE
WIPLINE MODEL 8000
AMPHIBIOUS AND SEAPLANE FLOATS**

Revision T

THIS PAGE INTENTIONALLY LEFT BLANK

LOG OF REVISIONS

Rev	Pages	Description	Date
A	3	Revised aircraft jacking position.	3/16/2005
B	12,18	Added greasing zerk to tasks and changed drawing.	9/28/2005
C	7, 12	Added an inspection time limit and tolerances for the Nose Block Track wear.	4/18/2006
D	19-22	Made several additions to the inspection checklist.	1/18/2007
E	9, 10, 15,16	Changes to the Cleaning, Corrosion and Main gear lubrication procedures and additional minor changes to the inspection checklist.	5/31/2008
F	29, 36, 46	Changed water rudder cable tensions.	8/15/2008
G	5, 6, 12, 13, 21	Changed main gear oleo servicing information. Added enhanced customer information pages and cleaning and corrosion pages.	7/15/2009
H	All	Reformat of entire document, Add green grease as approved grease, update to float procedures with clarification on rear door support cables.	4/18/2013
J	30, 31	Added Shear Torque Chart, PR 1440 C Sealant and Tef-Gel, Removed Warranty Claim Form.	5/26/2015
K	5, 14, 30, 31	Added Dow Corning DC4, Corrosion X, and Mobil Aviation Grease SHC 100 to approved product list. Modified torque limit section.	12/4/2015
L	18, 22, 28, 33-35, 42, 46	New document formatting (multiple pages renumbered). Changed main gear tire pressure from 45 +/- 5 PSI to 50 +/- 5 PSI. Replaced electrical schematic drawing for legibility. Added inspection for main gear cracking at annual. Changed silicone to Teflon spray. Added brake grease, corrected 6P-730A Teflon Spray to GP-730A. Removed new customer form. Removed repairing content found in Wipaire document 1008274. Edited retract and steering cable tensions. Added reference only note to metering pin.	11/7/2017
M	7	Added reference for Structural Repair Manual part number 1008274 in introduction.	5/1/2019
N	11, 16, 18, 31-37	Added information about corrosion limits. Added circuit breaker note to section 4.4 and Added note about STA-Lube. Updated details in Inspection Checklist about spreader bars and fly wires and emergency gear extension and retraction. Removed inspection column from Maintenance Checklist.	8/3/2020
P	18-21, 32, 34	Added sections 3.1 through 3.5. Changed gasket sealer to Tef Gel in section 5.3.1 Removal of Main Gear Oleo. Removed GP-730A from Comet Industries.	2/3/2021
R	9	Added note about Commercial Parts List 1011959 for STC SA1311GL.	8/26/2021
T	All	Updated Inspection Checklist.	3/24/2022

View most current revision of this ICA at www.wipaire.com.

THIS PAGE INTENTIONALLY LEFT BLANK

TABLE OF CONTENTS

INTRODUCTION.....	9
CHAPTER 1 GENERAL INFORMATION	11
CHAPTER 2 FLOAT HULL MAINTENANCE	13
CHAPTER 3 FLOAT HANDLING, JACKING, AND AIRCRAFT TOWING.....	17
CHAPTER 4 AMPHIBIAN LANDING GEAR SYSTEM OPERATION AND MAINTENANCE	23
CHAPTER 5 MAIN AND NOSE GEAR OPERATION, REMOVAL AND SERVICE	27
CHAPTER 6 WATER RUDDER RETRACTION AND STEERING SYSTEM.....	59

LIST OF FIGURES

FIGURE 3.1 JACK CRADLE RECOMMENDED MODIFICATION 19
FIGURE 3.2 JACKING LOCATION..... 19
FIGURE 3.3 FLOAT SECURING LOCATIONS..... 20
FIGURE 3.4 FLOAT SECURING LOCATIONS OVERVIEW 21
FIGURE 5.1 SCHEMATIC HYDRAULIC SYSTEM 52
FIGURE 5.2 SCHEMATIC ELECTRICAL SYSTEM 53
FIGURE 5.3 ASSEMBLY MAIN GEAR RETRACTION SYSTEM 54
FIGURE 5.4 ASSEMBLY – MAIN GEAR SHOCK STRUT 55
FIGURE 5.5 ASSEMBLY MAIN GEAR AND BRAKE..... 56
FIGURE 5.6 ASSEMBLY NOSE GEAR SYSTEM 57

Caravan

MODEL 208
FLOATPLANE

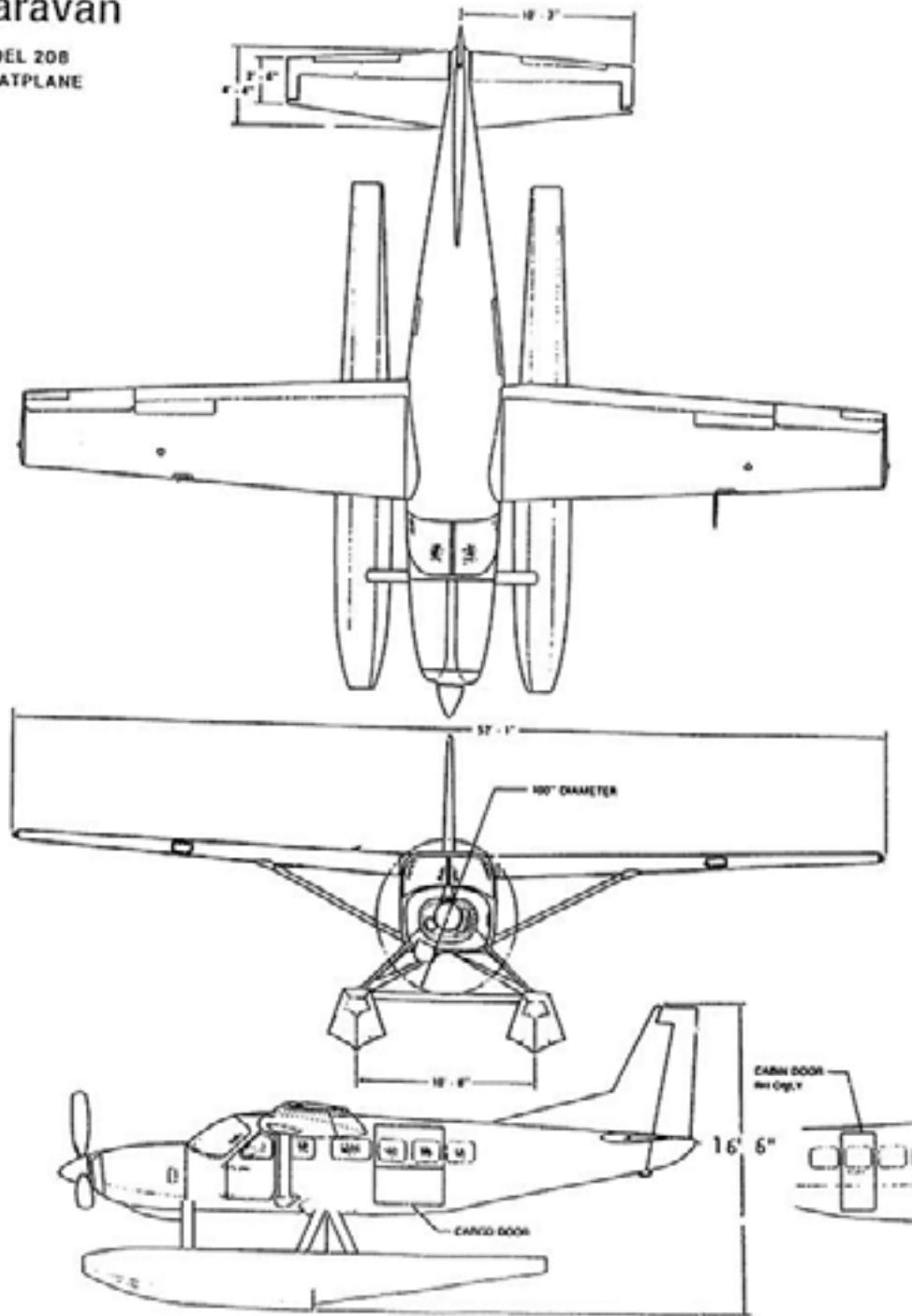

THIS PAGE INTENTIONALLY LEFT BLANK

INTRODUCTION

This manual describes the general servicing and maintenance for the Model 8000 float, including hull and landing gear. For services and repairs not covered by this manual contact Wipaire Customer Service.

When performing standard repairs for Wipline Aluminum Floats, please refer to the “Structural Repair Manual For Wipline Aluminum Floats” part number 1008274. It is available free of charge online at www.wipaire.com.

Reference Wipaire document number 1011959 for STC SA1311GL for a list of commercial parts.

The service products referred to throughout this manual are described by their trade name and may be purchased from the Wipaire Parts Department.

To contact Wipaire for technical support or parts sales, call, write or email:

Wipaire, Inc.
Customer Service
1700 Henry Avenue – Fleming Field
South St. Paul, MN 55075
Phone: (651) 306-0459
Fax: (651) 306-0666
Website: www.wipaire.com
Email: CustomerService@wipaire.com

THIS PAGE INTENTIONALLY LEFT BLANK

CHAPTER 1 GENERAL INFORMATION

CONTENTS

1.0 GENERAL	12
-------------------	----

1.0 GENERAL

The model 8000 seaplane or amphibious float is an all aluminum constructed float with watertight compartments. The actual displacement in fresh water for each float is 8108 pounds buoyancy for the seaplane and 7922 pounds buoyancy for the amphibian. The amphibian float is geometrically the same as the seaplane except for the addition of landing gear and internal structure for the gear.

The water rudder system is cable operated with ball bearing pulleys. Water rudder cables tie into the existing aircraft rudder system.

The main landing gear has dual 600 x 6 8-ply tires and the nose landing gear has one 500 x 5 10-ply tire. The gear system is hydraulically actuated and driven by two hydraulic pumps. Brakes are hydraulic and have a caliper on each main wheel for a total of four brakes.

Steering on land is accomplished by differential braking. The nose wheels are full castering.

Access to the float interior is accomplished by removing covers on the top deck and six covers inside the wheel well. When necessary, water inside the float hulls may be removed through pump out cups located on the outboard edge of each float top skin.

CHAPTER 2 FLOAT HULL MAINTENANCE

CONTENTS

2.1 GENERAL	14
-------------------	----

2.1 GENERAL

The float structure is manufactured entirely of 6061-T6 corrosion resistant aluminum sheet and extrusions. Skins on the inside are primed with a 3M SCOTCHWELD primer after being cleaned and acid-etched. Exterior surfaces are cleaned and alodined. Surfaces are then primed with an epoxy-based primer and finished with enamel color paint.

Hard Landing and Damage Investigation

After a thorough cleaning of the suspected damaged area, all structural parts should be carefully examined to determine the extent of damage. Frequently the force causing the initial damage is transmitted from one member to the next causing strains and distortions. Abnormal stresses incurred by shock or impact forces on a rib, bulkhead, or similar structure may be transmitted to the extremity of the structural member, resulting in secondary damage, such as sheared or stretched rivets, elongated bolt holes, deformed skins or bulkheads. Points of attachment should be examined carefully for distortion and security of fasteners in the primary and secondary damaged areas as locations beyond the local damage. Inspect aircraft tubes in area of float fitting for signs of bending, cracked welds, or any other damage.

Cleaning

The outside of the float should be kept clean by washing with soap and water.

Special care should be taken to remove engine exhaust trails, waterline marks, and barnacle deposits. After saltwater operation, washing with fresh water should be done daily with special attention to hard-to-reach places such as: seams, wheel wells, etc.

Alternatively, water taxiing in FRESH WATER at step-speed can help to flush the entire system.

OPERATORS IN SALTWATER ARE STRONGLY CAUTIONED – RINSING THE ENTIRE AIRCRAFT & FLOATS WITH FRESH WATER AT THE END OF EACH DAY OR PERIODICALLY IS CRITICAL. FAILING IN THIS CLEANING CAN SEVERLY SHORTEN THE LIFE OF THE FLOATS.

The float interior should be flushed if salt water enters the compartments. If the floats are being stored inside, remove inspection covers so the interior will dry out.

THE ABOVE CLEANING TECHNIQUES ARE VITAL FOR KEEPING CORROSION TO A MINIMUM. SALTWATER OPERATIONS AND ENVIRONMENT ARE STRONGLY LINKED TO CORROSION AND MUST BE ADDRESSED PROACTIVELY.

Corrosion

Reference the Wipaire Structural Repair Manual (SRM) for allowable corrosion/material loss limits. Corrosion is a reaction that destroys metal by an electrochemical action that converts metal to oxide. Corrosion is accelerated when in contact with dissimilar metals such as aluminum and steel, or any material that absorbs moisture like wood, rubber, or dirt.



After removing the corroded area, restore area to original finish (prime and enamel). Boeshield T9, Corrosion X, or ACF-50 may also be applied to stop corrosion. Refer to manufacturer's instructions for application instructions.

Maintaining the float inside and outside finishes by washing after saltwater operations will help protect the float from corrosion. Periodically all hardware should be covered with a waterproof grease or Par-al-ketone. Under saltwater conditions, bolts should be removed at least once a year and grease reapplied to the shafts, heads and nuts.

THE ABOVE CLEANING TECHNIQUES ARE VITAL FOR KEEPING CORROSION TO A MINIMUM. SALTWATER OPERATIONS AND ENVIRONMENT ARE STRONGLY LINKED TO CORROSION AND MUST BE ADDRESSED PROACTIVELY.

THIS PAGE INTENTIONALLY LEFT BLANK

CHAPTER 3 FLOAT HANDLING, JACKING, AND AIRCRAFT TOWING

CONTENTS

3.1 TOWING.....	18
3.2 HOISTING.....	18
3.3 LEVELING	18
3.4 JACKING PROCEDURES	18
3.5 JACK REMOVAL	21

3.1 TOWING

When towing the amphibian aircraft, 2 lugs are provided on the lower forward side of the nose spring.

On land, a rigid "V" frame can be fabricated to attach to these lugs for towing the aircraft with a tractor. Lake & Air Training and Pilot Shop has this tow bar available for purchase.



On water, a rope bridle arrangement can be used to tow the aircraft from the lugs described above.

3.2 HOISTING

Hoisting the aircraft can be performed using a lifting rig that attaches to the aircraft with lifting rings that are installed at the wing attach points. If the lifting rings are not installed, reference applicable aircraft maintenance/service manual for additional hoisting specifications. Lake & Air Training and Pilot Shop has this hoisting rig available for purchase. Contact Wipaire Customer Service for additional guidance in removal or installation of floats.

CAUTION!

Make sure nothing is under or above the airplane or floats when hoisting the aircraft

1. Raise aircraft high enough to place float cradle under floats as shown in Figure 3.4.
2. Lower aircraft onto float cradle as shown in Figure 3.4.
3. Place fore and aft supports as shown in Figure 3.3 and Figure 3.4.

3.3 LEVELING

See applicable aircraft maintenance/service manual.

3.4 JACKING PROCEDURES

CAUTION!

Make sure nothing is under or above the airplane or floats when jacking the aircraft.

1. Turn off fuel.
2. Place weighted bags above the nose gear (approximately 100 lbs. on each float to start, more may be added as needed).
3. Position 1 person at each fore and aft of each float, and 3 people at the jacking location of one float.
4. Modify jack saddle of a 3 ton minimum jack by welding as shown in Figure 3.1.

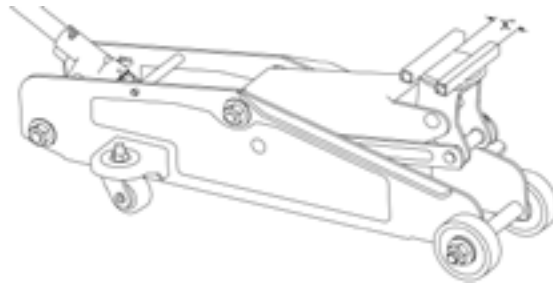

(X = WIDTH OF CRADLE)

FIGURE 3.1 JACK CRADLE RECOMMENDED MODIFICATION

NOTE: This is not required and Wipaire does not have the parts for modification. It is recommended a similar modification be performed to the jack saddle to prevent the slippage of the cradle.

1. Center cradle on saddle and position so cradle is as far aft on the main keel as possible without interfering with main gear as it decompresses as shown in Figure 3.2.

NOTE: If desired to prevent possible cosmetic damage to float, use material to separate cradle and float.



FIGURE 3.2 JACKING LOCATION

1. Jack one side at a time, taking care to check the balance of the aircraft and adding more weight to the front if needed.
2. Two people, both outboard, lift the fore and aft cradle stands up to the cradle as a 3rd person release the pressure slowly, allowing the cradle and stands to gently contact the ground.
3. Repeat previous procedure to the other float.

NOTE: A smaller jack may be needed to slightly lift the float into a high enough position for the main jack.

4. Secure floats with fore and aft supports as shown in Figure 3.3 and Figure 3.4.



FIGURE 3.3 FLOAT SECURING LOCATIONS



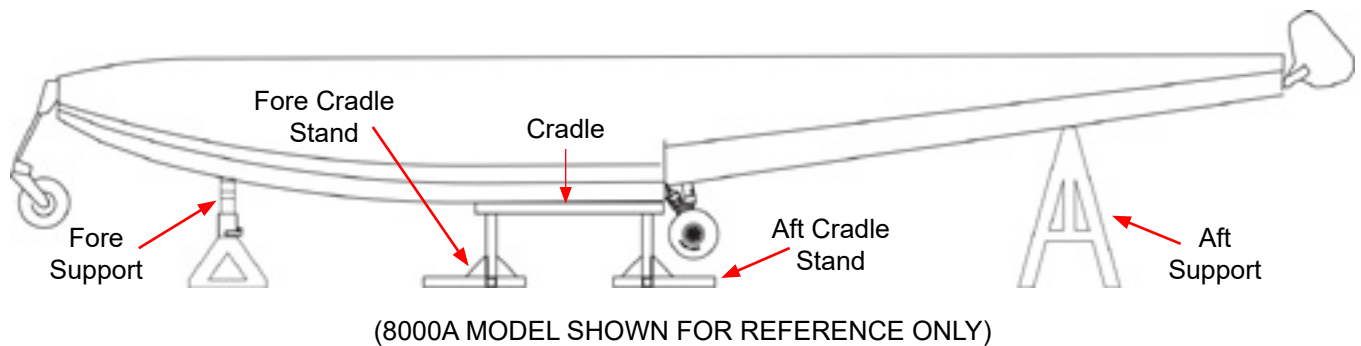

FIGURE 3.4 FLOAT SECURING LOCATIONS OVERVIEW

3.5 JACK REMOVAL

Make sure nothing is under or above the airplane or floats when removing the jacks from the aircraft

1. Turn off fuel.
2. Verify landing gear is in the down and locked position.
3. Verify weighted bags are still located above the nose gear.
4. Position 1 person at each fore and aft of each float, and 1 person at the jacking location of one float.
5. Remove all fore and aft supports as shown in Figure 3.3 and Figure 3.4.
6. Using modified jack saddle as shown in Figure 3.1, center jack saddle in center of cradle on 1 of the floats,
7. Lift aircraft to clear fore and aft cradle stands and remove fore and aft cradle stands of lifted float.
8. Slowly lower float to the ground, remove jack from under float, and remove cradle from jack saddle.
9. Repeat previous procedure to the other float.
10. Remove weighted bags from floats.

THIS PAGE INTENTIONALLY LEFT BLANK

CHAPTER 4 AMPHIBIAN LANDING GEAR SYSTEM OPERATION AND MAINTENANCE

CONTENTS

4.0 GENERAL	24
4.1 LANDING GEAR HANDLE	24
4.2 INDICATOR LIGHTS.....	24
4.3 LANDING GEAR OPERATION	25
4.4 EMERGENCY PUMP HANDLE.....	25

4.0 GENERAL

The landing gear incorporated within the amphibious floats on this airplane is retractable, quadricycle type with two swiveling nose (or bow) wheels and four (4) (two (2) sets of dual) main wheels. Air-oil shock struts on the two main landing gear assemblies provide shock absorption.

The main landing gear has dual 6:00 x 6 8-ply type III tires and the nose landing gear has one 5:00 x 5 10-ply tire. The gear system is hydraulically actuated and driven by two hydraulic pumps. Brakes are hydraulic and have a caliper on each main wheel.

Steering on land is accomplished by differential braking. The nose wheels are full castering.

Landing gear extension and retraction is accomplished by two (2) electrically-driven hydraulic pumps and four (4) hydraulic actuators (one (1) for each gear). The hydraulic pumps are located in fuselage aft of cockpit and the hydraulic actuators are located adjacent to each gear. Hydraulic system fluid level should be checked periodically by viewing the sight glass for fluid level in the upper one-third of the range. If fluid is low, fill with MIL-H-5606 or equivalent. Filters are installed on pickup tube inside of hydraulic reservoirs. Clean every 100 hours.

Landing gear operation is initiated by movement of the landing gear handle. When the handle is repositioned, hydraulic pressure in the system will drop and pressure switches will automatically turn on the hydraulic pump motors to maintain operating pressure in the system. When the gear cycle is completed, the pump will automatically shut off. If the pressure in the system drops to a preset value, the pressure switches turn the pump motors back on and build up the pressure to the limit again. Eight (8) position-indicator lights four (4) gear UP and four (4) gear DOWN are provided to show landing gear position. Two (2) additional indicator lights show when the landing gear pump motors are operating.

4.1 LANDING GEAR HANDLE

The landing gear handle controls a hydraulic selector valve within the selector head in the instrument panel and has two (2) positions (UP and DOWN LAND) which give a mechanical indication of the gear position selected. From either position, the handle must be pulled out to clear a detent before it can be repositioned.

4.2 INDICATOR LIGHTS

Ten (10) indicator lights are mounted on the landing gear control unit adjacent to the landing gear handle. Four (4) blue indicator lights, labeled NOSE and MAIN (left-hand lights for the left float and right-hand lights for the right float), show by their illumination that the landing gear is up and locked. The four (4) amber indicator lights, labeled NOSE and MAIN (left-hand lights for the left float and right-hand lights for the right float), are illuminated when the landing gear is down and locked.

Neither set of lights is illuminated when the landing gear is in transit. Two (2) red indicator lights, labeled PUMP ON 1 and 2 illuminate when current is supplied to the landing gear motors. If the motors continue running during flight or on and off repeatedly, the motors should be shut off by pulling AMPHIBIAN PUMP 1 AND AMPHIBIAN PUMP 2 circuit breakers, since continual running of the motors can result in premature motor failure. Prior to landing, the circuit breakers should be pushed in to reactivate the circuits. Troubleshoot hydraulic problem per section 5.4.

4.3 LANDING GEAR OPERATION

To retract or extend the landing gear, pull out on the landing gear handle and move it to the desired position. When the handle is positioned, pressure on the hydraulic system reduces to where the hydraulic motors automatically turn on. The motors power the hydraulic pumps and actuate the gear actuator for each gear. During operation of the landing gear motors the PUMP ON 1 and 2 indicator lights are illuminated. When the gear cycle is completed, pressure builds up in the hydraulic system and automatically shuts off the hydraulic motors. Each gear operates independently of the other, and therefore, the position lights illuminate at various times.

4.4 EMERGENCY PUMP HANDLE

An emergency hand pump is located on the floor between the front seats in the event the normal hydraulic system fails. This hand pump may be used to retract or extend the land gear. To actuate the hand pump, pull out the handle. Prior to utilizing the emergency hand pump, pull the AMPHIB PUMP 1 and 2 circuit breakers to deactivate the electric hydraulic pumps. Select UP and DOWN using the normal landing gear selector handle. Place the emergency hand pump handle in the pump and pump up and down. When a gear reaches the selected position, its indicator light will illuminate. After all four (4) gears are in the selected position there is a noted increase in resistance of hand pump operation.

When testing emergency pump, remember to push in the AMPHIB Pump 1 and 2 circuit breakers after the test is complete.

THIS PAGE INTENTIONALLY LEFT BLANK

CHAPTER 5 MAIN AND NOSE GEAR OPERATION, REMOVAL AND SERVICE

CONTENTS

5.1 DESCRIPTION AND OPERATION	28
5.1.1 SERVICE – NOSE GEAR	28
5.1.2 SERVICE – MAIN WHEELS AND BRAKES	29
5.1.3 SERVICE – MAIN GEAR OLEO	29
5.2 ADJUSTMENTS/TEST	29
5.2.1 NOSE GEAR	29
5.2.2 NOSE BOX TRACK WEAR	30
5.2.3 SERVICE – MAIN GEAR RETRACTION SYSTEM	30
5.2.4 BLEEDING HYDRAULIC SYSTEM AFTER SERVICE	31
5.3 MAIN AND NOSE GEAR REMOVAL AND DISASSEMBLY	31
5.3.1 REMOVAL OF MAIN GEAR OLEO	31
5.3.2 REMOVAL OF MAIN GEAR RETRACTION CYLINDER	35
5.3.3 REMOVAL OF MAIN GEAR DRAG LINK	35
5.3.4 REMOVAL OF NOSE GEAR FROM NOSE BOX	35
5.3.5 REMOVAL OF NOSE GEAR BOX	35
5.3.6 REMOVAL OF LOWER NOSE GEAR FROM PIVOT BLOCK	35
5.4 SERVICE SCHEDULE	35
5.5 HYDRAULIC PUMP SYSTEM, DISASSEMBLY AND SERVICE	38
5.6 INSPECTION TIME LIMITS AND CHECKLIST	40
5.7 FLOAT REMOVAL INSTRUCTIONS/PROCEDURES	45
5.8 FLOAT REINSTALLATION INSTRUCTIONS/PROCEDURES	48
5.9 WEIGHT AND BALANCE	58
5.9.1 WEIGHING PROCEDURES FOR CESSNA 208 CARAVAN	58

5.1 DESCRIPTION AND OPERATION

Retraction and extension of the main and nose landing gear is effected by a hydraulic actuation system shown schematically in figure 5.3.

The gear system is hydraulically actuated and driven by two hydraulic pumps located in the Aft fuselage. A pressure of between 500 and 1000 psi is maintained in the supply line. When the pressure falls below 500 psi, the pressure switch activates the pump solenoid, providing power to the pump. When the pressure reaches 1000 psi, the pressure switch deactivates the solenoid and the pump motor stops. Figure 5.2 shows the electrical schematic of the system. A check valve on the output side of the pump retains pressure in the system while the pump is off. The pump has an internal relief valve, which directs oil back to the pump reservoir when the line pressure exceeds 1200 psi. The system also has an internal relief valve to protect against thermal expansion when line pressure exceeds 1900 psi.

A cockpit mounted control valve accomplishes the selection of gear up or gear down. Each float gear has individual indicator lights on the control valve allowing the pilot to confirm that each gear has fully retracted or extended.

An emergency hand pump is provided, in case of total electric pump failure, or loss of fluid. The reservoir has additional hydraulic fluid, available only to the hand pump.

The main gear is mechanically locked in both up and down positions. Locking and unlocking is done utilizing a small amount of lost motion of the actuator rod. Retraction takes place when pressure is exerted on the actuator piston driving the collar along the slide tube. The lock is tripped when the follower slides up the contoured track in the actuator as shown in figure 5.3. A reverse process affects extension. Gear position light proximity switches are closed when the appropriate hook (containing the magnetic material) nests over the locking bar.

Shock absorption for the main landing gear is provided by a hydraulically dampened air spring. Figure 5.4 shows the main components. The oil and air share a common chamber. When the oleo is collapsed, the oil is forced through the main orifice, compressing the air in the upper cylinder. Extension reverses this process. The extended oleo is initially set at the factory to 210 psi no load. In-field adjustment of air pressure and oil volume is described in this section.

The nose gear has an over-center down lock. Retraction occurs when pressure is applied to the forward face of the actuator piston and the carriage is drawn along the tracks in the nose box as shown in figure 5.6. Gear position light proximity switches are closed when the piston containing the magnetic material has reached either end of its travel.

The nose gear consists of composite fiberglass beams that are attached at the bottom to castoring blocks. Inside the block is a castoring pin that is set into the machined fork assembly. The castoring pin allows the nose wheel to pivot in a complete circle. The geometry is such that no shimmy dampers are necessary. A spring loaded cam rides in a groove machined in the castoring pin. This groove as a flat surface on the back face with the result that the cam provides retention of the pin the block and self-centering of the wheel.

5.1.1 SERVICE – NOSE GEAR

The nose gear pivot assembly should be cleaned and inspected every 25 hours or more frequently whenever in water for extended period of time, especially saltwater. Nose gear tracks that are the older style gold track and white block are to be lightly greased. Apply grease to a cloth on a stick or rod and run along tracks inside of the nose box, both sides. Newer track and block that are black should be cleaned and left dry or alternately cleaned and wiped with a rag with dry teflon spray on it.

The nose wheels contain grease nipples for the wheel bearings. They should be greased every 25 hours.

Nose tires are standard 5:00 x 5, 10-ply, inflated to 60 +/- 5 psi.

5.1.2 SERVICE – MAIN WHEELS AND BRAKES

Grease nipples are provided on all wheels and bearings and should be greased every 25 hours or after an extended period of time in the water. Water/heat resistant grease is recommended, and it is important as with any aircraft operations not to mix types of products.

At brake installation, apply STA-Lube synthetic brake and caliper grease or equivalent to brake caliper pins. The dual piston brakes need no special care other than to maintain the brake disc free of rust, which causes premature brake lining wear. Bleeding is carried out in the usual manner from the bottom up.

Main wheel tires are standard 6:00 x 6, 8-ply type III aircraft tires, inflated to 50 +/- 5 psi. (Refer to figure 5-5).

5.1.3 SERVICE – MAIN GEAR OLEO

OIL LEVEL

The correct level is best set by draining and refilling with the correct quantity of fluid (1140 ml). This should be done with the oleo removed from the float, which process is outlined in Section 5.2.

CAUTION: Release air pressure and remove air valve before attempting to service oleo. After filling, refit valve and cap, then pressurize to 210 psi. (Note: Use only MIL-H-5606 hydraulic fluid).

AIR PRESSURE

The correct air pressure is 210 psi (+/-10 psi) on a fully extended oleo (no load) or it can be inflated to approximately 5-6 inches on an unloaded aircraft while sitting static on level ground.

SEALS

Seals should be replaced whenever the oleo is disassembled or leaking.

CAUTION! Release air pressure and remove air valve before attempting to disassemble oleo. The seals are standard “O” rings or T-seals whose part numbers are depicted in figure 5.4.

5.2 ADJUSTMENTS/TEST

5.2.1 NOSE GEAR

Adjustment of actuator stroke is provided at the ends of the piston rods.

The length of the nose gear rod is adjusted such that the over-center knuckle (brass) rollers just bottom out on the down side and the piston just bottoms out on the mounting flange.

The up stops nests in the up-stop pin. See figure 5.6 for location and assembly.

Nose gear proximity switches are located on clips that are mounted on the outer cylinder body, one on each end. The most forward switch is for the gear down lights and most aft is for the gear up position lights. Set the proximity switch mounting clip along outer cylinder body to a position such that the light goes out when the over-center track is about ¼ inch from bottomed position while traveling in the up direction. Lights should come on about 1/8 inch from the bottomed position while traveling in the down direction.

The cylinder piston has a magnet that will activate the proximity switches.

5.2.2 NOSE BOX TRACK WEAR

Due to wear over time the roller/slide block places on the track as the gear are retracted, the block needs to be measured for the amount of wear. The tolerance for wear is .050 inches. If the wear is, or is less than the limit, it can still be used. If the wear in the track is greater than .050 inches, the block must be replaced. This check is to be done every 200 hours and is part of the maintenance checklist.

On the 8000 Series Floats Gear Track P/N 8A07337 (-003 LT -004 RT).

5.2.3 SERVICE – MAIN GEAR RETRACTION SYSTEM

As explained in Section 5.0, retraction involves the main gear carriage moving back and forth along the slide tube. The locking mechanism also moves a small amount in service, enabling the locking hooks to hook and release as the gear locks in the up or down position. Consequently, the slide tube and the main gear ram must stay lubricated despite varying operating circumstances in order to work as intended.

Greasing might not be necessary, depending on operations, but these areas should be inspected visually at least every 25 hours for cleanliness and lubrication.

The slide tube, gear locking ram and main carriage can be accessed at various points of operation via the top deck panels or via the main wheel well with the tire off. Recommended grease is HCF Grease, P/N 605 available from our parts department. Care should be taken as with all aviation maintenance not to mix different types of greases, especially in critical areas like this. Grease needs to be applied directly along the length of the slide tube shaft and locking ram in addition to using a grease gun for the zerk on the main carriage. Grease should be pumped several times past the point at which it comes out the front of the carriage so it can migrate all the way thru the system to the locking hooks. Also, LPS 2 should be applied to the locking hooks while their top cover is removed.

The main gear actuator cylinder is not adjustable. These are pre-set at the factory to ensure that the main gear is locked at the end of each stroke and that correct indication is given on the cockpit console. The up and down lock may be adjusted so the lock is fully engaged by adjusting the set screws shown in figure 5.3. Loosen the jamb nut adjust and tighten jamb nut.

The main gear proximity switches are located on each end of the gear stroke. The forward switch is located on the forward side of the gear tunnel. It is accessible through the top deck access cover. The aft proximity switch is located on the float bulkhead just aft of the wheel well, accessible though the float top deck cover.

The main gear proximity switches are adjusted loosening the mounting screws and positioning them as such that the light goes out when the lock hook is raised about 1/8 inch off its nested position and comes on again upon nesting.

5.2.4 BLEEDING HYDRAULIC SYSTEM AFTER SERVICE

The system automatically bleeds, provided sufficient oil is maintained in the reservoir. To check the fluid level, fill the reservoir with hydraulic oil and cycle the gear. The fluid level should be maintained in the upper one third (1/3) of the sight glass. If the reservoir empties (i.e. fluid disappears in sight glass) stop the cycle by pulling the circuit breaker on the control panel. Fill the reservoir again and complete the cycle. Continue this procedure until the fluid level in the reservoir stabilizes (it will vary in level between up and down positions). If the fluid level continues to decline during gear cycles, check for external leaks.

5.3 MAIN AND NOSE GEAR REMOVAL AND DISASSEMBLY

5.3.1 REMOVAL OF MAIN GEAR OLEO

Jack the aircraft by method described in section 3. With the main wheels off the ground (both sides), run the gear up so the main carriages are approximately 2 inches forward of down-lock position. This must be accomplished to remove the top oleo bolt. In order to remove the lower bolt, remove the wheel on the head side of the bolt.

Shock Strut Servicing

NOTE: RELEASE PRESSURE IN STRUT BEFORE DISASSEMBLY!!

1. Disassemble the strut, removing both end caps. Take apart the gland section and metering pin so the parts can be easily inspected for wear and replacement parts can be installed as needed.



2. Inspect all parts carefully after cleaning for wear and scoring, especially the piston, gland section, and the inside of the outer cylinder. Also make sure to check the bushings in the end-caps for wear and security.
3. The metering tube does not need to be taken apart from the end-cap of the inside cylinder unless extensive cleaning is desired. If it is disassembled:
 - a. To return the metering tube height and condition to factory preset, first apply blue Loctite to the threads of the inner end-cap threads that hold the metering pin for added security until next removal.
 - b. The metering pin is threaded until the measurement from the floor of the inside of the end-cap to the end of the inserted metering tube is 12.037 inches if the new T-seals are being used and 11.937 inches if the old style O-rings are used.
 - c. Tighten the associated jam nut at that end and stake it for added security.
 - d. Set this metering tube assembly aside and move on to next steps.



Showing model 13000
metering pin for
measuring location
reference only

4. On the other end, install the metering pin with Loctite onto the end-cap and tighten to approx. 30 ft./lbs.
5. Install outer T-seal to end-cap with Vaseline. Also lube the inside of the outer cylinder where the end-cap seats for ease of assembly.

NOTE: Use Vaseline or equivalent as it dissolves in hydraulic fluid.



6. Install the end-cap bolts with Tef Gel on the threads for added security. Tighten to 25-30 in/lbs. making sure not to over-tighten, damaging the T-seal. Set this part of the unit aside and move on to next steps.



7. To assemble the gland assembly, insert the inside T-seal and wiper, again using Vaseline on the T-seal.
 - a. The gland must be installed from the end-cap side (this is the side without the holes).
 - b. Lube the outside of the inner cylinder with hydraulic fluid for ease of assembly.
 - c. Install the T-seal into the end-cap, again using Vaseline for lube.
 - d. Install the inner cylinder into the end-cap (the end of the tube without holes).

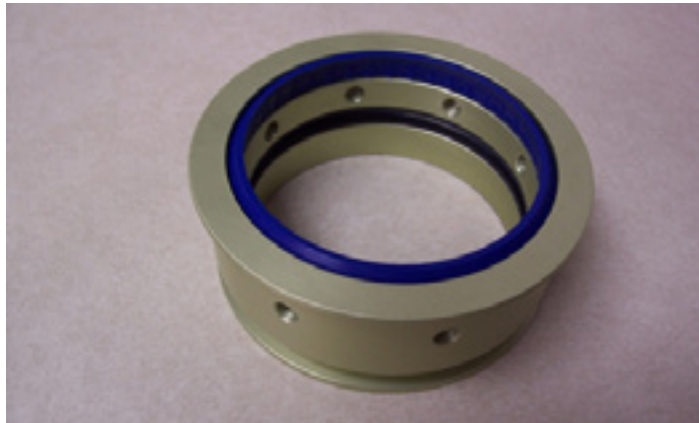

9. Gently clamp the outer tube end in a vise and add 1140 ml of hyd. fluid (5606 or equivalent).
10. Lube the inside of the outer cylinder where the gland and the piston will rest.
11. Install the inner cylinder into the outer assembly, making sure that the gland is seated against the piston.



12. Re-install the center bolts using Tef Gel.



13. Install the O-ring onto the fill/drain plug before installing the plug onto the end-cap and tighten.



14. Install the O-ring onto the Schraider valve and install onto the outside of the end-cap.

NOTE: Align Schraider valve 180 degrees from the Placard.

NOTE: Double check the plugs and bolts for proper installation and security before adding gas charge.

15. Fill the strut with nitrogen to 210 psi +/- 10 psi and close the valve and cap.



5.3.2 REMOVAL OF MAIN GEAR RETRACTION CYLINDER

Relieve pressure in system, place gear selector handle in neutral position (lever between up and down), and remove hydraulic lines. Remove end cap from end of cylinder. Drain fluid. Remove forward end of cylinder from bulkhead flange. Remove cylinder support ring from bulkhead. **NOTE:** Piston to be in the up position for cylinder removal. Remove cylinder from piston and up through top float inspection cover. To remove piston, remove top inspection cover on top forward end of gear tunnel, accessible from top float inspection cover forward of step. Pull back piston to expose top of carriage in center of access cover. Remove .25 dia. retention bolt. Remove piston by pulling aft. See figure 5.3 for part breakdown.

5.3.3 REMOVAL OF MAIN GEAR DRAG LINK

Remove drag link from trunnions on step bulkhead. Axle is heat shrunk to drag link and is not removable.

5.3.4 REMOVAL OF NOSE GEAR FROM NOSE BOX

Gear must be in down position. Relieve pressure in system, place gear selector handle in neutral position (lever between up and down), and remove rear hydraulic line. Remove (4) bolts on forward end of cylinder. Drain fluid. Pull aft to expose internal piston rod. Loosen jamb nut on forward side of cylinder ram at rod end. Turn piston from aft side of nose box out of rod end. Lift up on gear assembly to unlock. Slide out of nose box. **Note:** On installation adjust piston so it bottoms out on aft flange when nose gear is in locked position. Also note orientation of trolley blocks. The side with the most edge distance from hole is to go toward each other on inside of trolley. (See figure 5.6 for details).

5.3.5 REMOVAL OF NOSE GEAR BOX

Remove bolts securing forward box from nose bulkhead. Remove bolts securing aft box from bulkhead (2). Slide box out from front of float. **Note:** Sealant will have to be cut for removal and replaced when installing.

5.3.6 REMOVAL OF LOWER NOSE GEAR FROM PIVOT BLOCK

With weight off of the nose wheel, remove 2 bolts on plate on aft side of pivot block. Remove spring and detent piston. Nose fork assembly will drop down from pivot block.

5.4 SERVICE SCHEDULE

As coded in the Inspection Time Limits chart in this section, there are items to be checked each 25, 50, 100, and 200 hours. Also, there are notes on special items which may require servicing at more frequent intervals.

- When conducting an inspection at 25 hours, all items marked for 25 hours would be accomplished.

- When conducting an inspection at 50 hours, the 25 and 50-hour items would be accomplished.
- When conducting an inspection at 100 hours, the 25, 50, and 100-hour items would be accomplished.
- When conducting an inspection at 200 hours, the 25, 50, 100, and 200-hour items would be accomplished.
- A complete inspection (Annual Inspection) would include all 25, 50, 100, and 200-hour items.

When servicing float hull and amphibian components, below is list of recommended lubricants and “protection” products. This lists products used by Wipaire during assembly of the floats.

There may be equivalent products that are just as satisfactory for protection. It is recommended if trying different products, to inspect them frequently so as to determine their effectiveness.

Protection of nuts, bolts, hydraulic lines or metal surfaces

Zip D-5029NS Corrosion Inhibiting Compound
Zip Chemical Company

CRC – SP400 Soft Seal
CRC Industries

General Lubricants

LPS 1, LPS 2 and LPS 3
LPS Industries

Wheel Bearings

*HCF Grease, P/N 605
HCF Industries

*Aeroshell 22
Shell Global Solutions

*Green Grease, Multi-Purpose
Green Grease Inc.

*Aviation Grease SHC 100
ExxonMobil Aviation Lubricants

Rust Protection

Boeshield T9 Rust Protection
Boeing Company

Corrosion X
Corrosion Technologies Corp.

ACF-50 Rust Protection

Tef-Gel
Ultra Safety Systems, Inc.

Float Sealant

890 B2 or B4
Pro Seal Company

PR 1440 C
PPG Aerospace

1422 B2, B4 or B6
Pro Seal Company

RTV Silicones
General Electric

SIKAFLEX 201 or 252
Sika Manufacturing

Electrical Insulating Compound

Dow Corning 4 (DC4)
Dow Corning Corporation

Brake Grease

SL3303
Sta-Lube Brake Caliper Synthetic Grease

* If existing grease cannot be identified you must lubri-flush all float grease fittings until visibly exhausting all old grease and new grease is coming out. Additionally if you cannot determine existing grease in wheel bearings, completely clean and repack bearings with new grease.

Hydraulic Fluid

Mil-H-5606

As general inspection guidelines, each of the following areas should be inspected for their own unique attributes:

Movable Parts

For lubrication, servicing, security of attachment, binding, excessive wear, safeying, proper operation, proper adjustment, correct travel, cracked fittings, security of hinges, defective bearings, cleanliness, corrosion, deformation, sealing, and tension.

Fluid Lines and Hoses

For leaks, cracks, dents, kinks, chafing, security, corrosion, and deterioration

Metal Parts

For security of attachment, cracks, metal distortion, broken welds, corrosion, condition of paint, and any other apparent damage.

Wiring

For security, chafing, burning, defective insulation, loose or broken terminals, corroded terminals.

Bolts in Critical Areas

For corrosion, correct torque when installed, or when visual inspection indicates a need for a torque check.

Nut torque should be applied depending on the hardware application, unless the torque is specified for a certain joint in this manual or installation drawings.

****Tension Application**

Nut-Bolt Size	Torque Limits In-lbs	
	Min.	Max.
8-36	12	15
10-32	20	25
1/4-28	50	70
5/16-24	100	140
3/8-24	160	190
7/16-20	450	500
1/2-20	480	690
9/16-18	800	1,000
5/8-18	1,100	1,300
3/4-16	2,300	2,500
7/8-14	2,500	3,000
1-14	3,700	4,500
1 1/8-12	5,000	7,000
1 1/4-12	9,000	11,000

****Shear Application**

Nut-Bolt Size	Torque Limits In-lbs	
	Min.	Max.
8-36	7	9
10-32	12	15
1/4-28	30	40
5/16-24	60	85
3/8-24	95	110
7/16-20	270	300
1/2-20	290	410
9/16-18	480	600
5/8-18	600	780
3/4-16	1,300	1,500
7/8-14	1,500	1,800
1-14	2,200	3,300
1 1/8-12	3,000	4,200
1 1/4-12	5,400	6,600

**A Torque of 80% should be used when Tef-Gel is applied to the bolt.

Some additional general maintenance areas are as follows:

Nose and Main Gear Tracks

Clean and lubricate with a dry Teflon coating spray.

Joints

Spray all joints with light penetrating oil such as LPS 3 to ensure lubrication at all times.

Electrical Connections

Apply SP-400 SOFT SEAL or LPS 500 to all electrical connections to prevent corrosion.

Hydraulic Fluid

For use in all hydraulic systems, including brakes: MIL-H-5606.

5.5 HYDRAULIC PUMP SYSTEM, DISASSEMBLY AND SERVICE

The hydraulic pump is factory preset to the following pressures:

Pressures switch operates below 500 psi and shuts off at 1000 psi.

The pump also has an internal relief valve that opens at 1200 psi and a thermal relief valve that opens at 1900 psi. These pressures are set with factory test equipment and are recommended to be sent back for overhaul or repair.

The unit may be disassembled for cleaning.

Relieve the pressure in the hydraulic system by placing the gear selector handle in the neutral position.

1. On the forward lower side of the reservoir, remove drain plug to drain most of the hydraulic fluid.
2. Remove the (4) screws on each tank (2) on upper side of the reservoir.
3. Dump out remaining oil, and clean reservoir.
4. Unscrew stand pipe with the filter attached.
5. Clean filter.
6. If filter is removed from stand pipe, a new filter should be used.
7. Reinstall tank and install seals to top of reservoir before installing on pump.
8. Install drain plug and fill with clean MIL-H-5606 hydraulic fluid through the breather pipe.
9. Fluid level should be in the upper 2/3 of the sight gauge.

5.6 INSPECTION TIME LIMITS AND CHECKLIST

INSTRUCTIONS / PROCEDURES		HOURLY LIMITS					MECHANIC	
		25	50	100	200	ANN	RT	LT
General	Wash aircraft and floats with fresh water and inspect surfaces, hardware and strut connections for corrosion.	X or more often				X		
	Spreaders Bars	X						
	Check installed placards against the AFM or POH, and installation drawings.			X		X		
Hulls & Struts	Float Installation		X			X		
	Boarding steps: disassemble as needed and grease the step slide tubes.			X		X		
	Disassemble and grease the flying wire clevis bolts/pins and fittings.					X		
	On the aircraft and floats: re-coat exposed hardware with suitable coating for corrosion protection.			X		X		

INSTRUCTIONS / PROCEDURES		HOURLY LIMITS					MECHANIC	
		25	50	100	200	ANN	RT	LT
Float Interiors	Float structure (interior): pull up baggage floors and inspect bulkheads. Pull up all top deck covers and wheel well covers to inspect seals.	Closely inspect for wrinkled metal & cracked flanges; watch closely bulk heads 9-21.		X			X	
	Baggage compartment covers and seals - inspect for condition, security, operation, excessive wear and corrosion under nutplates.	After hardware inspection, coat with anti-corrosion grease to protect.		X			X	
	Pumper Tube Installation - inspect for condition, security, routing of hoses.				X		X	
Water Rudder System and Tail	Water rudder boots - inspect for cuts, tears, and condition	Water rudder blades and posts - inspect for damage, security of attachment, corrosion, paint, rigging. Check post bolts and bushings and lube with LPS 2. Clean and inspect post for cracks.		X			X	
	Water rudder steering and retract systems - inspect the following: cables for broken wire; fittings for cable slippage, cracks and distortion; cable pulleys for freedom of rotation and cable guard pins for presence; rigging Check cable bolt to pivot arm AN3-6A for wear	Check top and bottom rollers for rotation and lube with LPS 2 or similar product. Tension steering cables to 30 +/- 5 lbs and retract cables from 5 – 10 lbs		X			X	
	On the aircraft: remove clean, inspect and grease the aux. finlets on the horizontal stabilizer.						X	
Electrical System	Pump and indicator light wiring - inspect for chafing, broken or loose terminals and general condition.			X			X	

INSTRUCTIONS / PROCEDURES		HOURLY LIMITS						MECHANIC	
		25	50	100	200	ANN	RT	LT	
		Solenoids - inspect wiring, mounting and general condition.			X			X	
Pressure Switches - inspect wiring, mounting and general condition.			X			X			
Pump Motors - inspect wiring, mounting and general condition.			X			X			
Landing Gear Systems									
Inspection and servicing nose gear tracks	Gold and white track and block clean and use grease. Black track and block – clean and dry or clean and wipe with teflon spray.	X				X			
Nose gear box/block tracks measure at slide route for wear, .050 inches or less wear tolerance	Check side play -3/32 to 1/16 inches max tolerance				X	X			
Nose gear pivot blocks and forks - inspect for condition, lubrication, corrosion, paint.	Clean and Inspect	X				X			
Nose & main wheel bearing - grease Zerks		X				X			
Clean and Inspect Main gear slide tube, ram and locking hooks for lubrication. Lube carriage zerk liberally.	Grease with HCF P/N 605. Spray locking hooks form the top with LPS 2 to penetrate.	X				X			
Hydraulic fluid level: Mil-H-5606			X			X			
Wheels and tire - inspect for wear, pressure, condition (main: 50 lbs +/- 5 lbs, front: 60 lbs +/- 5 lbs)			X			X			

INSTRUCTIONS / PROCEDURES		HOURLY LIMITS						MECHANIC		
		25	50	100	200	ANN	RT	LT		
	Brake assemblies - inspect for wear, corrosion, leakage		X			X				
	Hydraulic fluid screen - clean and inspect. NOTE: If floats sit for extended periods of time (i.e. If removed during winter months), screen should be cleaned before putting floats back into service. Hydraulic fluid in reservoir should be checked for moisture or other contaminants and changed if necessary.			X		X				
	Insp. FWD slide tube mounting bolt for corrosion and wear when the gear are out. Clean and lube the slide tube before returning.					X				
	Main and Nose gear actuator, assemblies - inspect for condition, lubrication, leakage, corrosion, and cleanliness.			X		X				
	Omit the following if Service Letter 180 has been previously accomplished. Remove all bolts and inspect drag brace tube and axle assembly.					X				
	Nose gear springs - scotchply springs, inspect for cracks, delamination and paint.			X		X				
	Main gear drag link garloock bushings - inspect for condition, lubrication, and corrosion.			X		X				
	Clean the wheel wells to facilitate general condition inspection.			X		X				

INSTRUCTIONS / PROCEDURES		HOURLY LIMITS						MECHANIC	
		25	50	100	200	ANN	RT	LT	
	Main gear oleos - inspect for evidence of leakage, proper extension, check cylinder for corrosion, pitting, cleanliness and security			X		X			
	Hydraulic lines and fittings - inspect for leaks, condition and security.				X	X			
	Hydraulic Manifolds (if equipped) - inspect for condition, security, and leaks.					X			
	Brake system plumbing - inspect for leaks, condition and security.					X			
	Main gear oleos – Check for static compression, leaks and proper pressure. The oleo should be fully serviced or replaced with overhauled as required.			X		X			
	Perform retraction test:						X		
							X		
							X		
							X		
							X		
							X		
							X		
	Nose and main wheel bearings – disassemble and inspect			X					

5.7 FLOAT REMOVAL INSTRUCTIONS/PROCEDURES

THIS IS INTENDED AS A GENERAL GUIDE. EACH INSTALLATION MAY HAVE SUBTLE DIFFERENCES. ALWAYS USE THE INSTALLATION DRAWINGS AS THE FINAL REFERENCE. ALL WORK SHOULD BE DONE BY CERTIFIED AIRCRAFT TECHNICIANS.	MECHANIC RIGHT	MECHANIC LEFT	INSP.
1. Connect the lifting bar to the hoist and position aircraft underneath			
2. Remove wing gap strips			
3. Inspect aircraft lifting rings for proper assembly and installation before connecting the lifting bar to the aircraft			
4. Attach ropes and ballast to tie-down rings as required to keep aircraft level while lifting			
5. Lower aircraft so wheels just touch and relieved hydraulic pressure before pulling pump circuit breakers. Install tie-wrap to shank for safety.			
6. Remove from aircraft:			
• Nose gear cover plate			
• Lower left cowling			
• Steering bungee from nose gear attach			
• Front flying wire fitting			
• Strut fairings and belly plate			
• Tail hatch cover and tail cone (if needed)			
• Rear cargo struts and step assembly			
• Auxiliary fins (cover holes with cover plates)			
• Nuts from top bolts in forward struts			
• Bolts from front step struts			
• Cotter pins from pulley brackets under cargo door			
• Aft cabin bulkhead and cabin seats as required			
• Floor cover plates for access to steering cables			

THIS IS INTENDED AS A GENERAL GUIDE. EACH INSTALLATION MAY HAVE SUBTLE DIFFERENCES. ALWAYS USE THE INSTALLATION DRAWINGS AS THE FINAL REFERENCE. ALL WORK SHOULD BE DONE BY CERTIFIED AIRCRAFT TECHNICIANS.	MECHANIC RIGHT	MECHANIC LEFT	INSP.
• Fairleads from under the cabin floor			
• Elevator down-spring and cable			
• Hydraulic lines at the RT. front strut location and cap			
• Retract cable (Secure in main gear well)			
• Break lines and cap			
• Electrical cannon plug in main wheel well			
• Steering cables in tail. Remove rudder horn or clamp to main rudder Cables			
7. Assemble main gear if needed			
8. Install nose gear and attach steering bungee			
9. Assemble support crew (minimum 6 people)			
10. With wheels just touching the ground, remove the 4 main gear saddles and upper front attach bolts			
11. Lift aircraft and remove floats			
12. Lower aircraft and install main gear assembly			
13. Torque main gear saddle bolts to 75 ft. lbs			
14. Connect brake lines and bleed for air bubbles			
15. Install main gear belly plate and fairings			
16. Remove front strut fittings			
17. Install pilot and co-pilot step assemblies			
18. Replace Cargo Door Cable Assy. (2) P/N S2837-2 with original Cable Assy. (2) P/N S2837-1 (optional)			

THIS IS INTENDED AS A GENERAL GUIDE. EACH INSTALLATION MAY HAVE SUBTLE DIFFERENCES. ALWAYS USE THE INSTALLATION DRAWINGS AS THE FINAL REFERENCE. ALL WORK SHOULD BE DONE BY CERTIFIED AIRCRAFT TECHNICIANS.	MECHANIC RIGHT	MECHANIC LEFT	INSP.
19. Install tail cone and tail hatch cover			
20. Install lower LT. cowling			
21. Install all nose gear fittings			
22. Install all floor plates and carpet			
23. Install aft bulkhead			
24. Install any seats previously removed			
25. Remove aircraft from hoist & add air to tires as required			
26. Install wing-root fairings			
27. Check all placards to conform to landplane category			
28. Make logbook entry			
NOTES:			

5.8 FLOAT REINSTALLATION INSTRUCTIONS/PROCEDURES

THIS IS INTENDED AS A GENERAL GUIDE. EACH INSTALLATION MAY HAVE SUBTLE DIFFERENCES. ALWAYS USE THE INSTALLATION DRAWINGS AS THE FINAL REFERENCE. ALL WORK SHOULD BE DONE BY CERTIFIED AIRCRAFT TECHNICIANS.	MECHANIC RIGHT	MECHANIC LEFT	INSP.
1. Remove the nose and main gear fairings and the belly plate			
2. Remove wing gap strips and the tail cover			
3. Install the finlets and seal			
4. Remove aft panel inspection covers for hydraulic pump access and cables			
5. Remove pilot and co-pilot steps			
6. Install front strut fittings			
7. Disconnect brake lines and cap			
8. Cut tie-wrap from pump circuit breakers			
9. Tie ropes from tie-down rings. Connect lifting bar to hoist and inspect aircraft lifting rings for proper assembly before connecting to aircraft. Use ballast from tie-down ropes to ensure level lifting.			
10. Raise aircraft until wheels are just touching the ground and assemble crew (minimum 6 people) for installation			
11. Remove saddles holding main gear in place. With support crew stabilizing aircraft, hoist aircraft clear of main gear and roll away from aircraft			
12. Lube saddles on aircraft and saddle bolts and position float under plane			
13. Lower aircraft to floats, install front struts first then lower aircraft onto saddles and install clamps			
14. Torque the saddle bolts to 75 ft/lbs			
15. Remove the nose gear			
16. Install the flying wire fitting. Install flying wires, rig with regard to airflow			
17. Secure the steering bungee & connect the hydraulic lines			
18. Locate jack stands under floats			

THIS IS INTENDED AS A GENERAL GUIDE. EACH INSTALLATION MAY HAVE SUBTLE DIFFERENCES. ALWAYS USE THE INSTALLATION DRAWINGS AS THE FINAL REFERENCE. ALL WORK SHOULD BE DONE BY CERTIFIED AIRCRAFT TECHNICIANS.	MECHANIC RIGHT	MECHANIC LEFT	INSP.
19. Perform gear check & ensure all lights agree with gear and gear advisory			
1. Cycle time up? Cycle time down? Check for leaks.			
21. Hand pump the gear down and up and check for leaks again.			
22. Install springs for steering cables in the tail of the aircraft			
23. Route and rig the steering cables & water rudder retract cables 30 lbs. +/- 5			
24. Install step struts			
25. Replace Cargo Door Cable Assy. (2) P/N S2837-1 with Cargo Door Cable Assy. (2)P/N S2837-2			
26. Install break lines and bleed for air bubbles			
27. Install elevator down-spring			
28. Install belly plate and fairings for main gear			
29. Install tail inspection cover, cowlings and wing gap strips			
30. Inflate main gear tires to 50 lbs +/- 5 lbs, front to 60 lbs +/- 5 lbs			
31. Remove aircraft from stands. Check for proper main oleo extension (section 5)			
32. Check aircraft placards against the drawings for accuracy			
33. Plug nose leg fairing holes and pilot and co-pilot step holes.			
34. Make logbook entry & check for proper placarding.			

DESCRIPTION AND OPERATION

PROBLEM – Powerpack does not run after gear selection.

PROBABLE CAUSE

- Circuit breaker has failed
- Pressure switch not pulling in at low cut in.
- Solenoid switch not pulling in.
- Faulty pump motor.
- Motor not properly grounded.

VERIFICATION AND REMEDY

- Reset circuit breaker.
- Short across pressure switch leads and see if motor runs. If motor operates, replace pressure switch.
- Short across solenoid pressure switch leads and see if motor runs. If motor operates, replace solenoid pressure switch.
- If above does not produce results and it is verified that voltage was actually applied to motor, it can be assumed motor is bad or not properly grounded.
- Check motor ground.

PROBLEM – Powerpack does not shut off after gear reaches position.

PROBABLE CAUSE

- Faulty pressure switch.
- Faulty or dirty pressure relief valve allowing insufficient pressure buildup.

REMEDY

- Replace pressure switch.
- Clean and check relief valve.

PROBLEM – Powerpack shuts off before gear reaches position.

PROBABLE CAUSE

- Binding or jammed gear retractor, which causes pressure to build up (and stay up), and pressure switch shuts off powerpack.
- Faulty or dirty pressure relief valve allowing insufficient pressure buildup.

REMEDY

- Repair retractor.

PROBLEM – Powerpack cycles on and off after gear is in position.

PROBABLE CAUSE

- Internal hydraulic leak.
- External hydraulic leak.

REMEDY

- Verify leak is not external by checking fluid level in reservoir and looking at couplings for oil leaks. If no external leaks are found, disconnect and cap off the hydraulic actuators one at a time and find the leaky one by process of elimination. If isolating entire system still indicates internal leak, powerpack check valve (located in pressure port of pump) is bad and needs replacement or reseating.
- Visually inspect lines, cylinders, and hoses and replace as necessary.

PROBLEM – Powerpack cycles on and off during gear cycle.

PROBABLE CAUSE

- Binding in retraction unit.
- Pressure switch cut off limit too low.

REMEDY

- Investigate for free operation. Check gear that retracts last.
- Replace pressure switch.

PROBLEM – Slow gear operation cycle (considerably longer than 30 seconds.)

PROBABLE CAUSE

- Plugged oil screen.
- Poor electrical connection to motor.
- Poor motor.
- Worn pump gears.

REMEDY

- Clean intake screen located inside reservoir tank.
- Connect motor direct to 24 volt source and note its operation; if good, wire connection is bad; if operation poor, motor needs overhaul.
- Covered in b. above.
- Replace pump.

PROBLEM – Circuit breaker pops during cycle.

PROBABLE CAUSE

- Wire connections bad or corroded.
- Bad motor brushes.
- Bad circuit breaker.

REMEDY

- Clean and protect terminal with grease.
- Overhaul motor.
- Replace circuit breaker.

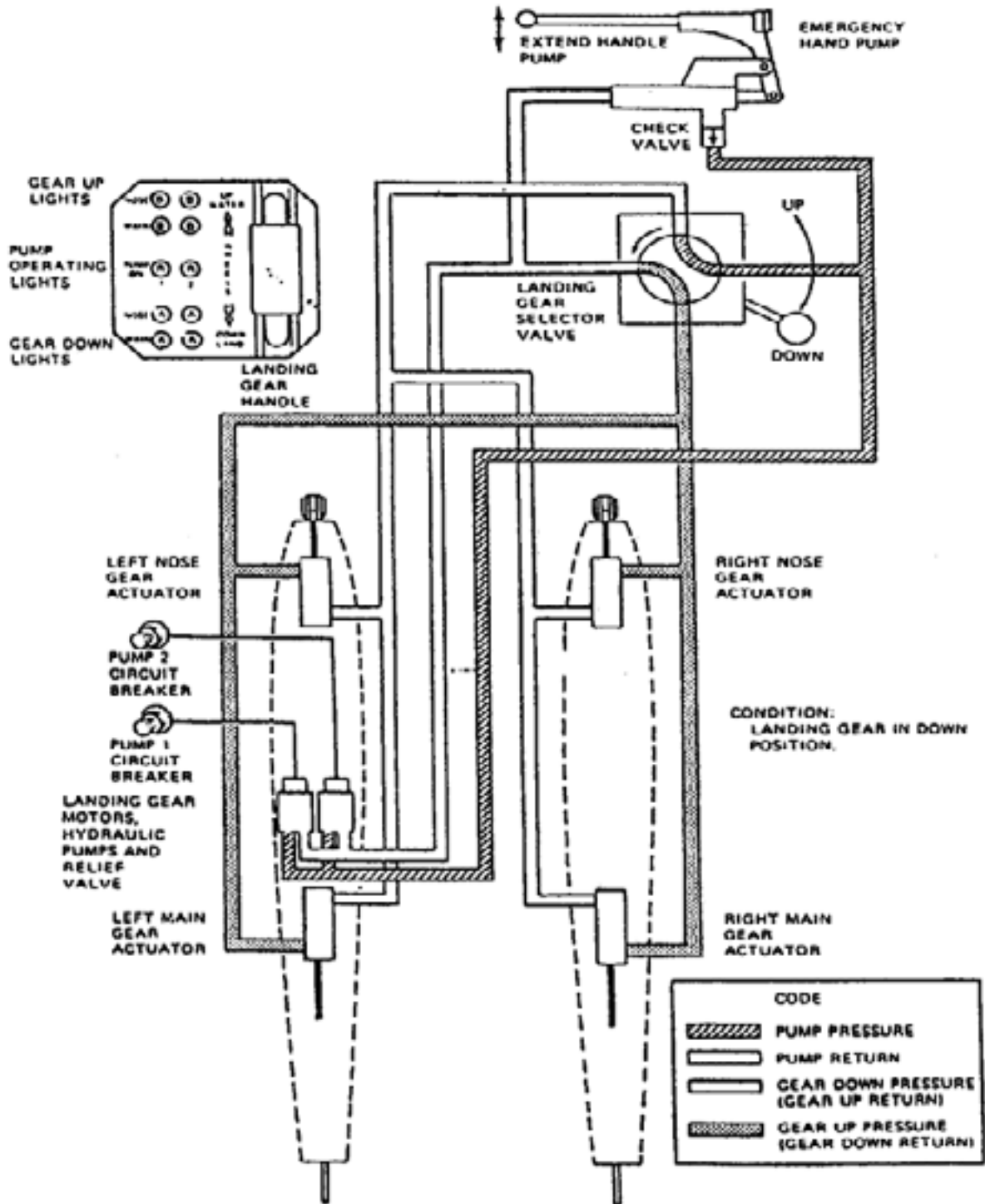

FIGURE 5.1 SCHEMATIC HYDRAULIC SYSTEM

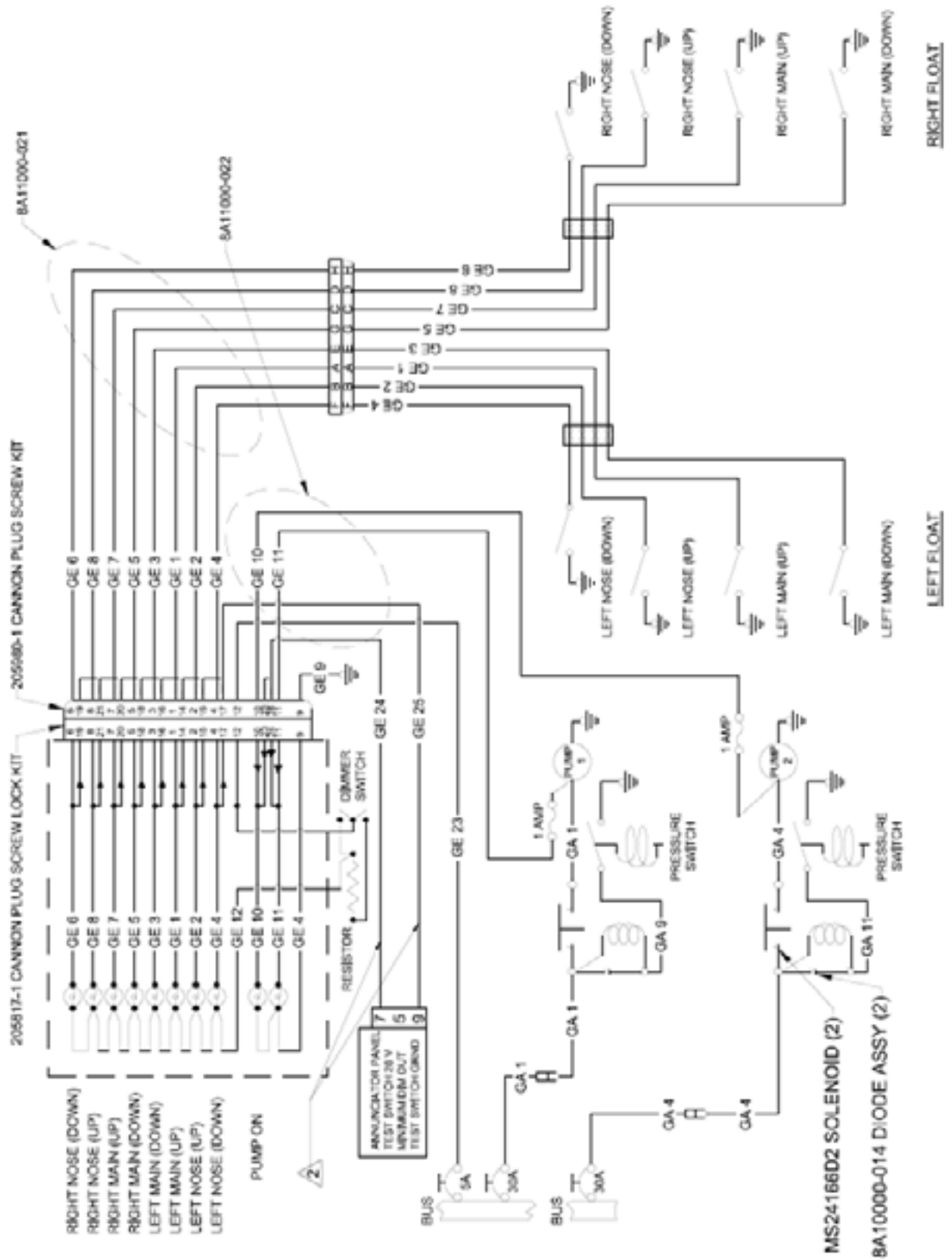

FIGURE 5.2 SCHEMATIC ELECTRICAL SYSTEM

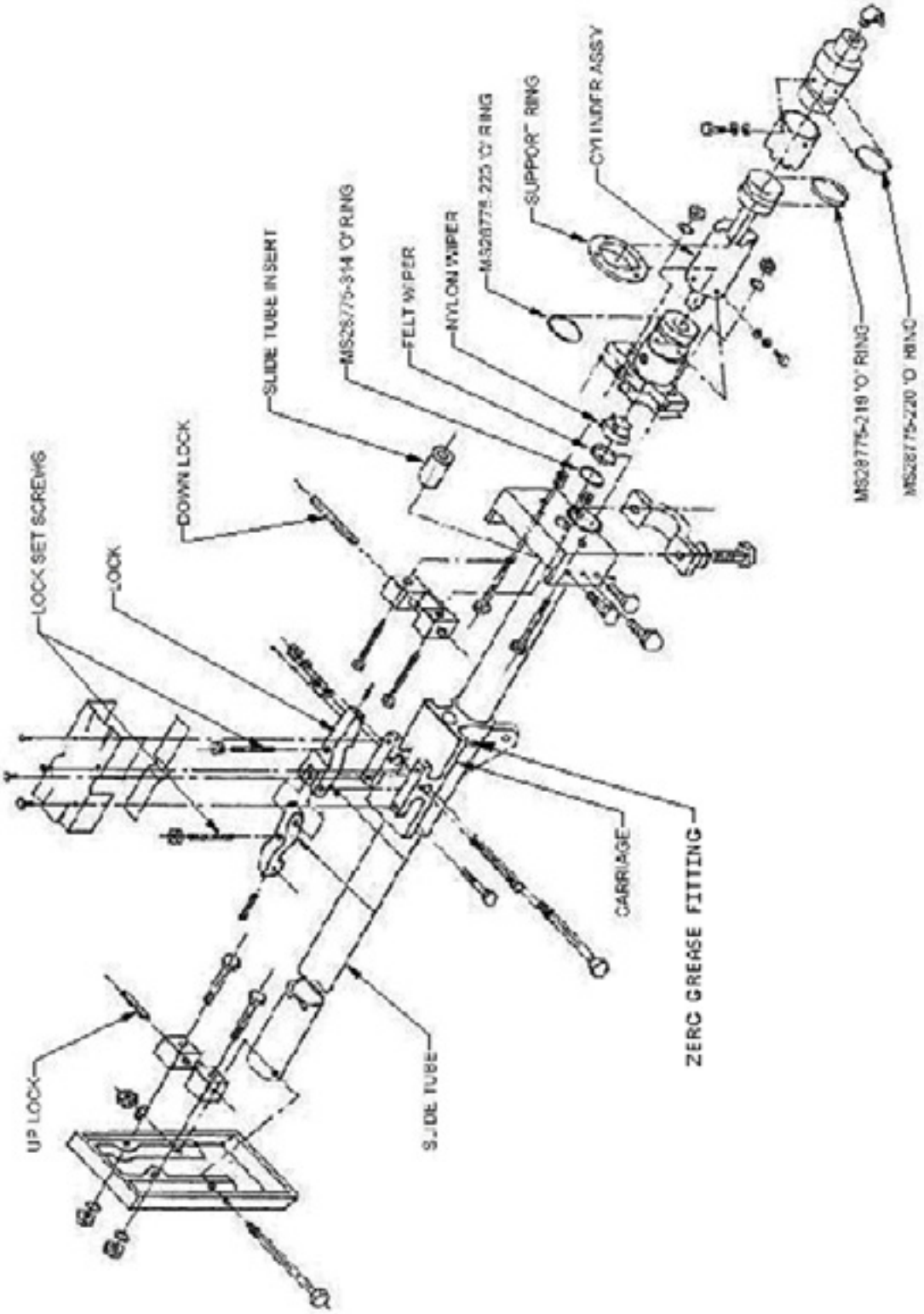

FIGURE 5.3 ASSEMBLY MAIN GEAR RETRACTION SYSTEM

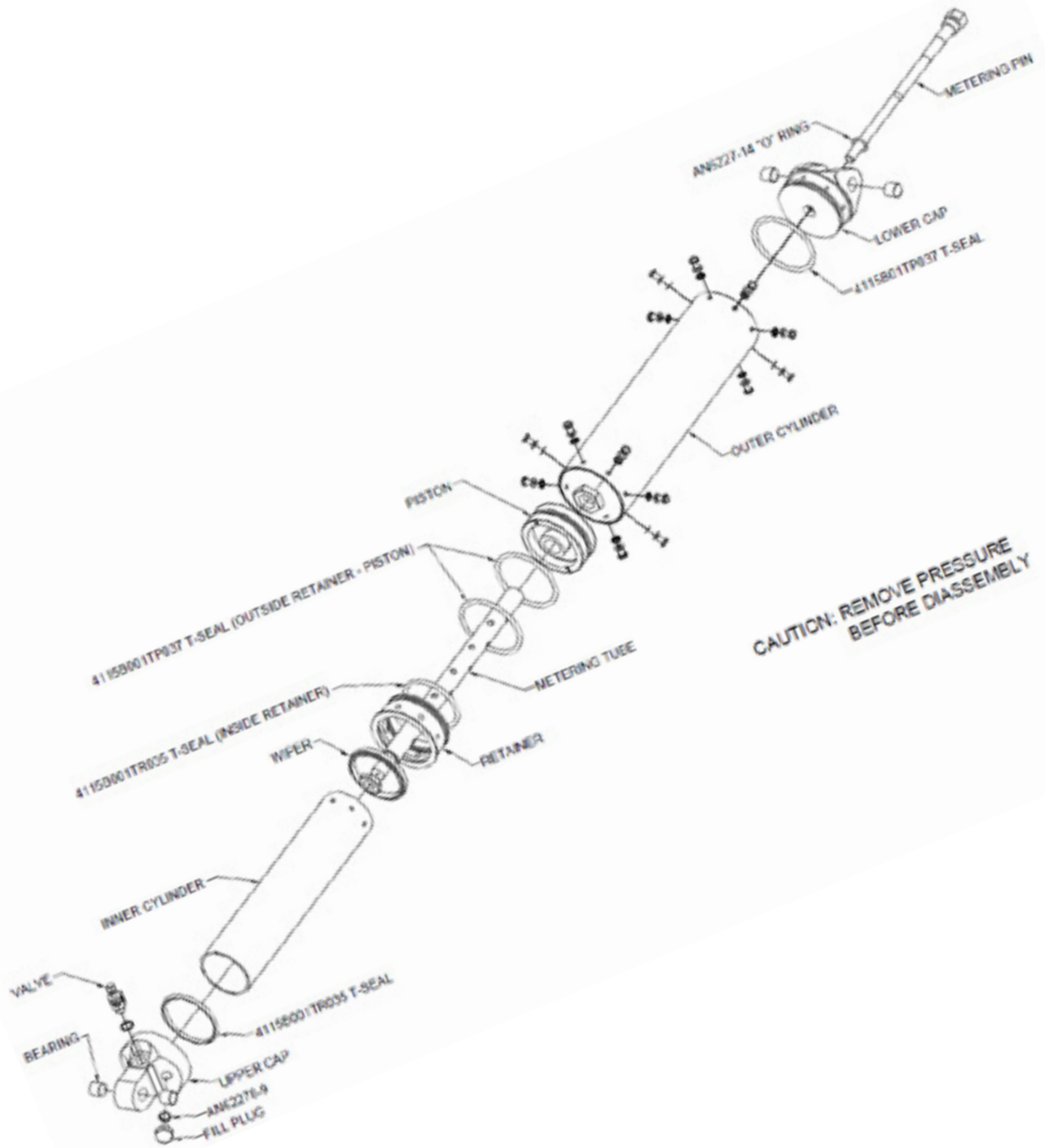

FIGURE 5.4 ASSEMBLY – MAIN GEAR SHOCK STRUT

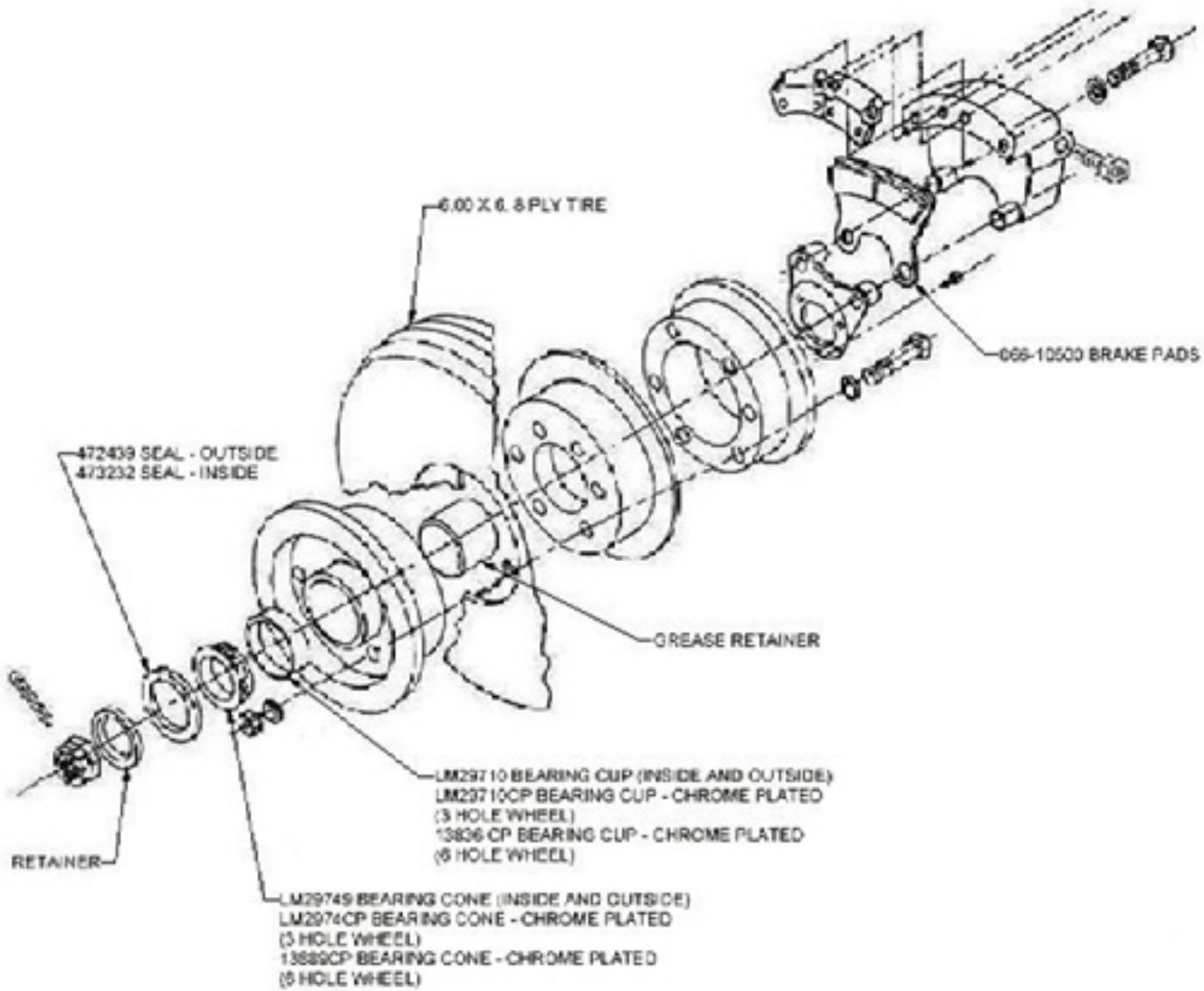

FIGURE 5.5 ASSEMBLY MAIN GEAR AND BRAKE

(Refer to Parts Manual for complete parts list)

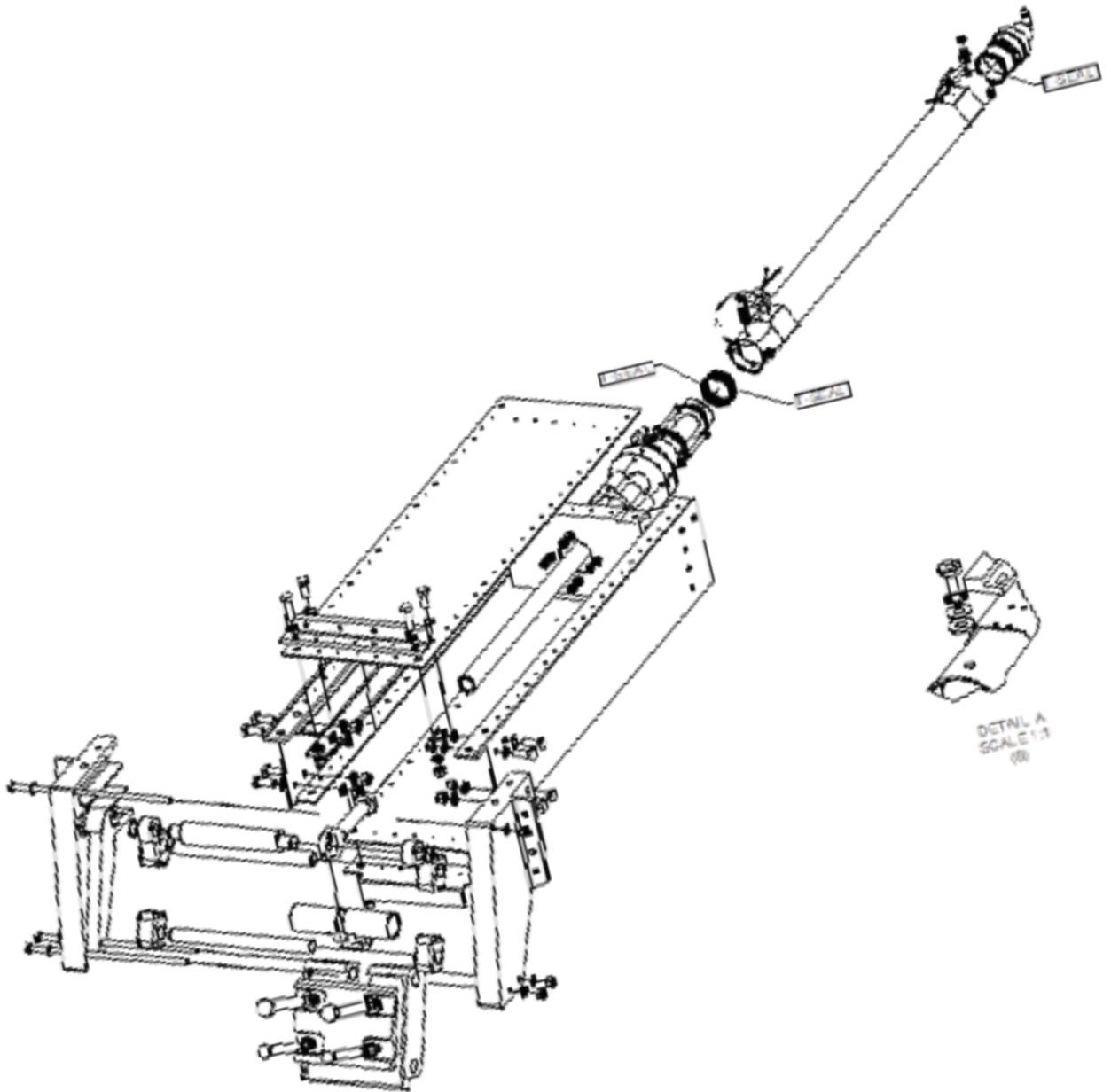

FIGURE 5.6 ASSEMBLY NOSE GEAR SYSTEM

5.9 WEIGHT AND BALANCE

5.9.1 WEIGHING PROCEDURES FOR CESSNA 208 CARAVAN

1. Level aircraft per manufacturer's instructions or use the cabin door lower sill.
2. Place scales under the right and left main and nose gears.
3. Place blocking under the right and left main gears to level aircraft.
4. Draw lines on the floor from the centerline main wheels and centerline nose wheel left to right.
5. Drop a plumb bob from the face of the firewall. This is station 100.00. Measure 100.00 inches forward of this point, this is the datum, 0.0.
6. Draw another line between the nose wheel centers and a 4th line between the main wheel centers.
 - Measure the distance from 0.0 to the nose wheel line. This is X1 and X2.
 - Measure the distance from 0.0 to the main wheel line. This is Y1 and Y2.

NOTE: If the floats are seaplane floats, the scales go under the step point in the rear and a point towards the front of the float. These distances are measured and become the same X and Y as for the amphibian.

	WEIGHT	x	ARM	=	MOMENT
	Scale Reading		Distance from 0.0		Weight x Arm
Left Front	+	+	X1		
Right Front	+	+	X2		
Left Rear	+	+	Y1		
Right Rear	+	+	Y2		
Totals					

Notes:

1. Zero out or deduct tare weights at the Y arm.

CHAPTER 6 WATER RUDDER RETRACTION AND STEERING SYSTEM

CONTENTS

6.1 DESCRIPTION	60
6.2 ADJUSTMENT	60
6.3 SERVICE SCHEDULE	60

6.1 DESCRIPTION

The water rudder-retract system is manually operated by a lever through a system of cables and pulleys.

Steering is directed from the aircraft rudder steering system.

6.2 ADJUSTMENT

Rigging of the water rudder steering cables is accomplished by centering the airplane rudder and adjusting the turnbuckles such that both rudders trail with the float center line. Cables should be tensioned to 30 lbs. +/- 5.

Retraction cables should be rigged such that the top of the rudder blade is against the rudder stop on the rudder posts in the up position and that the cables are just slack in the down position.

6.3 SERVICE SCHEDULE

Cables - inspect for fraying annually.

Pulleys - inspect and lubricate annually.