



- MANUFACTURERS OF WIPLINE FLOATS & SKIS
- SPECIALISTS IN AIRCRAFT MODIFICATION

1700 Henry Avenue - Fleming Field
South St. Paul, MN 55075
651-451-1205

SERVICE KIT: #54

DATE ISSUED: 9/7/2022

SUBJECT: Horizontal Panel and Trunion Removal for weight reduction.

MODEL: 13000 Seaplane floats designed S/N 13066 and prior with the ability to convert from Amphibian.

INSTRUCTIONS: Instructions assume Service Letter #59 has been accomplished for the Tunnel Removal (Figure 1, #9).

Horizontal panel removal: Remove all rivets that connect the horizontal panel (Figure 1, #1) to the #17 bulkhead. Remove the rivets that connect the horizontal panel to the side skins. Carefully break loose any sealer around the Horizontal panel using a putty knife or similar scraping tool. (Be very careful not to damage the skins or the bulkhead with the scraping tools). If the float is not taken apart, you may have to cut the horizontal panel into small pieces using a cut-off wheel, so you can remove it through the top access hole. After the horizontal panel is removed, all the rivet holes on the #17 bulkhead, and the rivet holes on the side skin must be filled with rivets to plug the holes. When this is completed, make sure to water check the compartments involved to make sure there are no leaks. (This is very important).

Trunion removal: Remove the 8 bolts on the trunnions. Break loose the sealer from around the trunion using a putty knife or similar scraping tool. (Be careful not to damage the bulkhead with the scraping tool. Remove the trunnions. Plug bolt holes with bolts. (Make sure to seal the bolts by dipping them in sealer before installing them). When this is completed, make sure to water check the compartments involved to make sure there are no leaks. (This is very important).

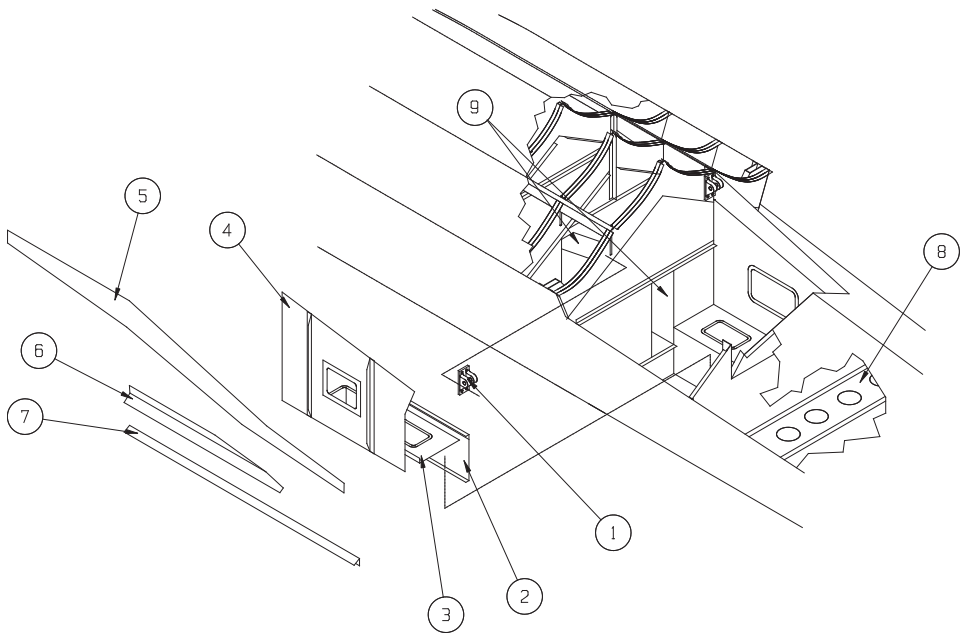

Figure 1

Obsolete... Superseded by Se

etter 74