



WIPLINE FLOATS • SKIS • MODIFICATIONS • AIRCRAFT SALES
AVIONICS • INTERIOR • MAINTENANCE • PAINT REFINISHING

SERVICE LETTER 198

GEAR ADVISORY (AGAS) RETROFIT

Aircraft Makes/Model(s):	Float Model(s):	Compliance: Optional	By: MAB
All aircraft equipped with Lake and Air Gear Advisory P/N 9600-1A	All amphibian float models	Part Number: 1011060	Approved: SDW
		Date: 10/8/2021	Revision: E

LOG OF REVISIONS

Revision	Description	Date
A	Initial release	8/22/2019
B	Added wire drawing schematic overview for kits	10/17/2019
C	Added 12V and 24V bulbs to parts list, drawings, and work instructions	1/9/2020
D	Updated images, titles, and instructions.	7/9/2020
E	Changed Airspeed Switch 7481712 to 7481-712 in kits and work instructions.	10/8/2021

FAA approval has been obtained for technical data in this publication that affects STC or TSO design compliance.



Lake and Air P/N 9600-1A

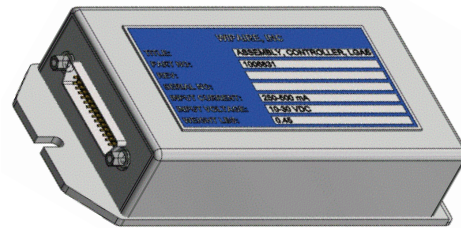

AGAS MK II/LGAS P/N 1006831

EFFECTIVITY:

This service letter applies to all aircraft that have been equipped with a Lake and Air Amphibian Landing Gear Position Advisory System (AGAS) P/N 9600-1A with Wipline Amphibious Floats installed per STC SA39CH.

COMPLIANCE:

Optional compliance

BACKGROUND:

The original Shadin/Lake and Air Amphibian Gear Advisory System has been discontinued and is no longer available. It is being replaced by the AGAS MKII/LGAS assemblies in new float kits. This installation is to retrofit the Shadin Gear Advisory Computer with the Wipaire Gear Advisory Computer, along with its associated wiring.

COMPLIANCE METHOD:

Replace the computer system per the Work Instruction section of this service letter.

1700 Henry Ave - Fleming Field (KSGS), South St. Paul, MN 55075

Phone: 651.451.1205 | Fax: 651.457.7858

www.wipaire.com

APPROXIMATE SHOP HOURS:

Replacing the computer, including installation of associated wiring, will take approximately 8 labor hours.

WARRANTY INFORMATION:

This service letter does not include warranty for labor and parts.

TECHNICAL DATA:

Copies of this service letter, associated service kit (if applicable), float service manual, and float parts manual are available by contacting Wipaire customer service.

ITEMS PROVIDED IN SERVICE KIT 1011060-01 (BI-DIRECTIONAL, HYDRAULIC PUMP)

ITEM	QTY	PART NUMBER	DESCRIPTION
1	1	1006831	ASSEMBLY, CONTROLLER, LGAS
2	1	1006838	WIRE HARNESS, GEAR SELECTOR SWITCH
3	1	1008291	WIRE HARNESS, ADAPTOR, AGAS
4	1	7481-712	AIRSPPEED SWITCH
5	1	R-1	BUTT CONNECTOR
6	1	327	LIGHT BULB, 24V
7	1	330	LIGHT BULB, 12V

*POHSA39CH Airplane Flight Manual Supplement for Amphibian Gear Advisory System is required. Contact Wipaire Customer Service for an updated revision.

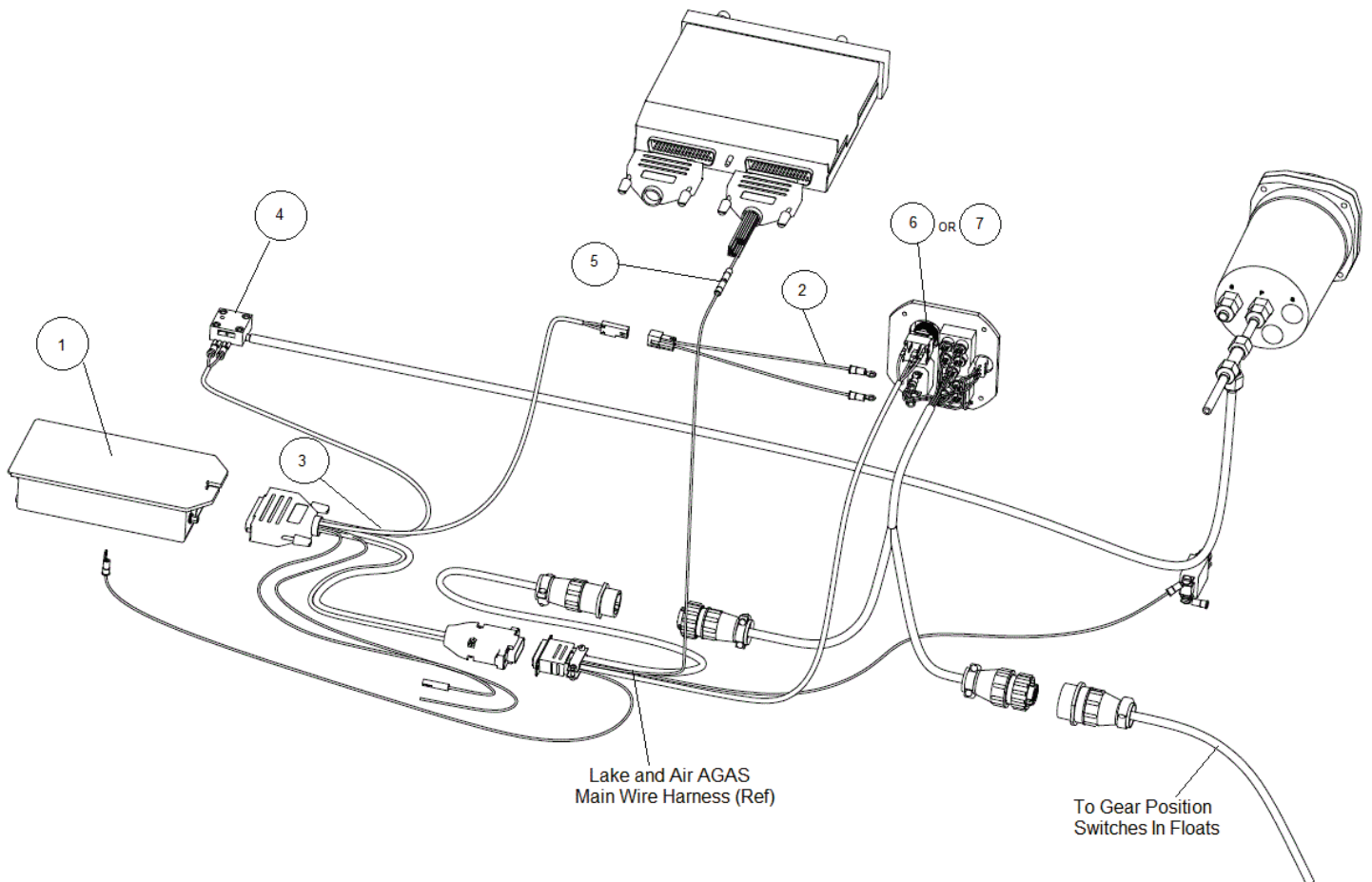

ITEMS PROVIDED IN SERVICE KIT 1011060-02 (UNI-DIRECTIONAL, HYDRAULIC PUMP)

ITEM	QTY	PART NUMBER	DESCRIPTION
1	1	1006831	ASSEMBLY, CONTROLLER, LGAS
2	1	1008291	WIRE HARNESS, ADAPTOR, AGAS
3	1	1008301	BRACKET, MICRO SWITCH
4	1	1008326	WIRE HARNESS, MICRO SWITCH
5	1	66099-4	CRIMP PIN, MALE, 18-16G
6	1	7481-712	AIRSPEED SWITCH
7	2	MS21044N02	NUT, SELF-LOCKING, 2-56"
8	2	MS35206-207	SCREW, MACHINE CROSS, 2-56 THREAD, 1/2" LENGTH
9	1	R-1	BUTT CONNECTOR
10	1	327	LIGHT BULB, 24V
11	1	330	LIGHT BULB 12V

*POHSA39CH Airplane Flight Manual Supplement for Amphibian Gear Advisory System is required. Contact Wipaire Customer Service for an updated revision.

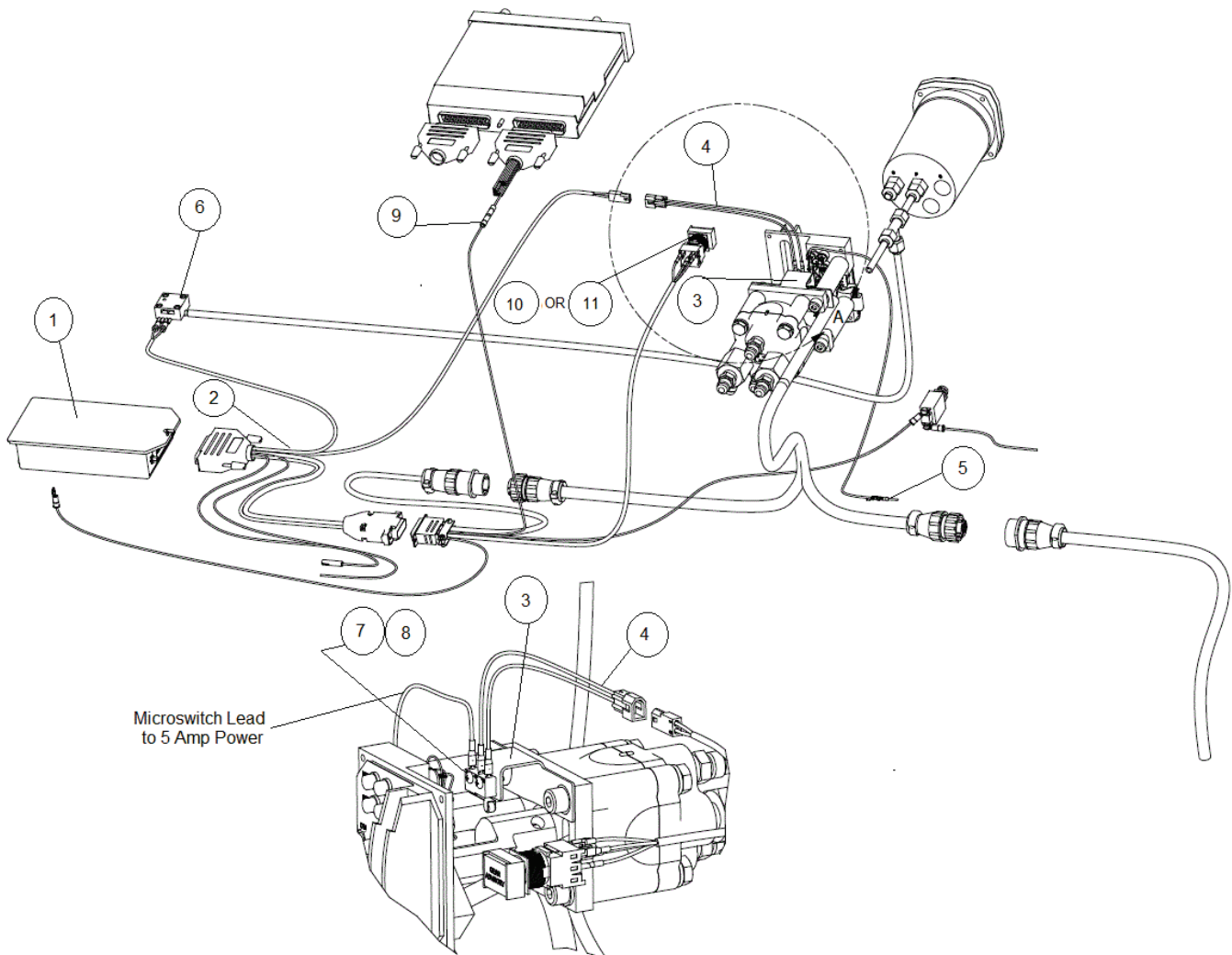

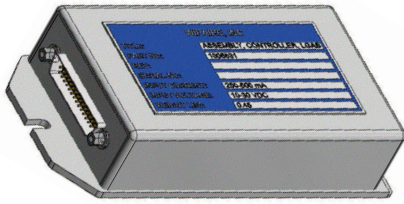

New Wipaire Controller (1006831)

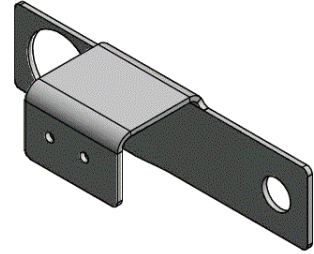

Bracket, Micro Switch (1008301)

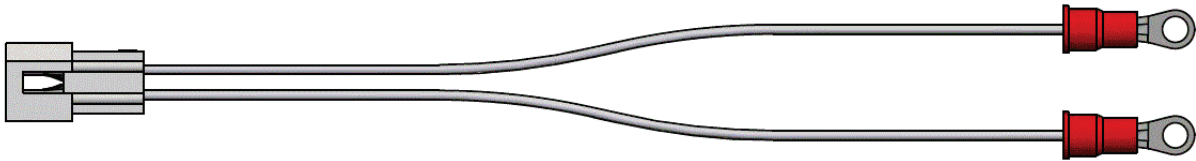

Wire Harness, Gear Selector Switch (1006838)
Electric, Bi-Directional Handle Assembly

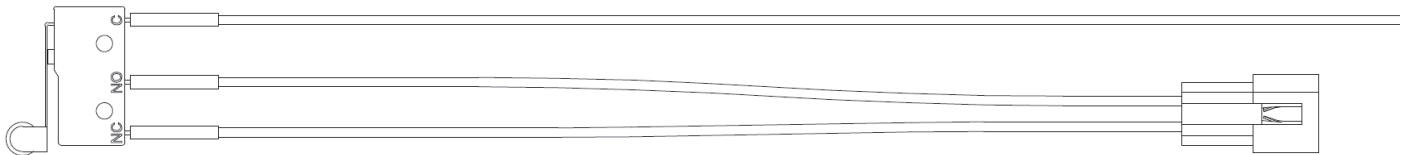

Wire Harness, Micro Switch, AGAS (1008326)
Hydraulic, Uni-Directional Handle Assembly

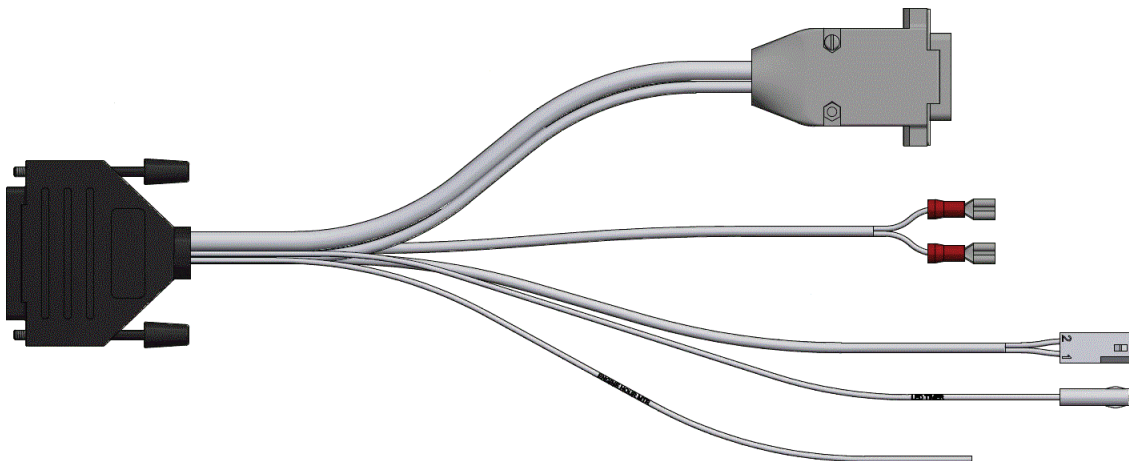

Wire Harness, Adaptor, AGAS (1008291)

WORK INSTRUCTION

1. Remove 26 pin plug and pitot line from Shadin Gear Advisory Computer. Remove Shadin Gear Advisory Computer from tray.
2. Install Wipaire Gear Advisory Controller 1006831 onto existing tray and secure with thumb nut.
3. Install 26 pin connector from wire harness 1008291 into existing wire harness. Install 44 pin connector from 1008291 into 1006831 Gear Advisory Controller.
4. Install airspeed switch 7481-712 into pitot line and route wires from wire harness 1008291 onto airspeed switch per schematic. After installing airspeed switch, set airspeed switch by putting a multimeter set to continuity on the contacts of the switch and setting the airspeed from a pitot static test box to the desired speed per the chart. Once airspeed is set, adjust screw on airspeed switch until the contact closes. Perform a pitot leak check per AC 43.13-1B, chapter 12, section 4.

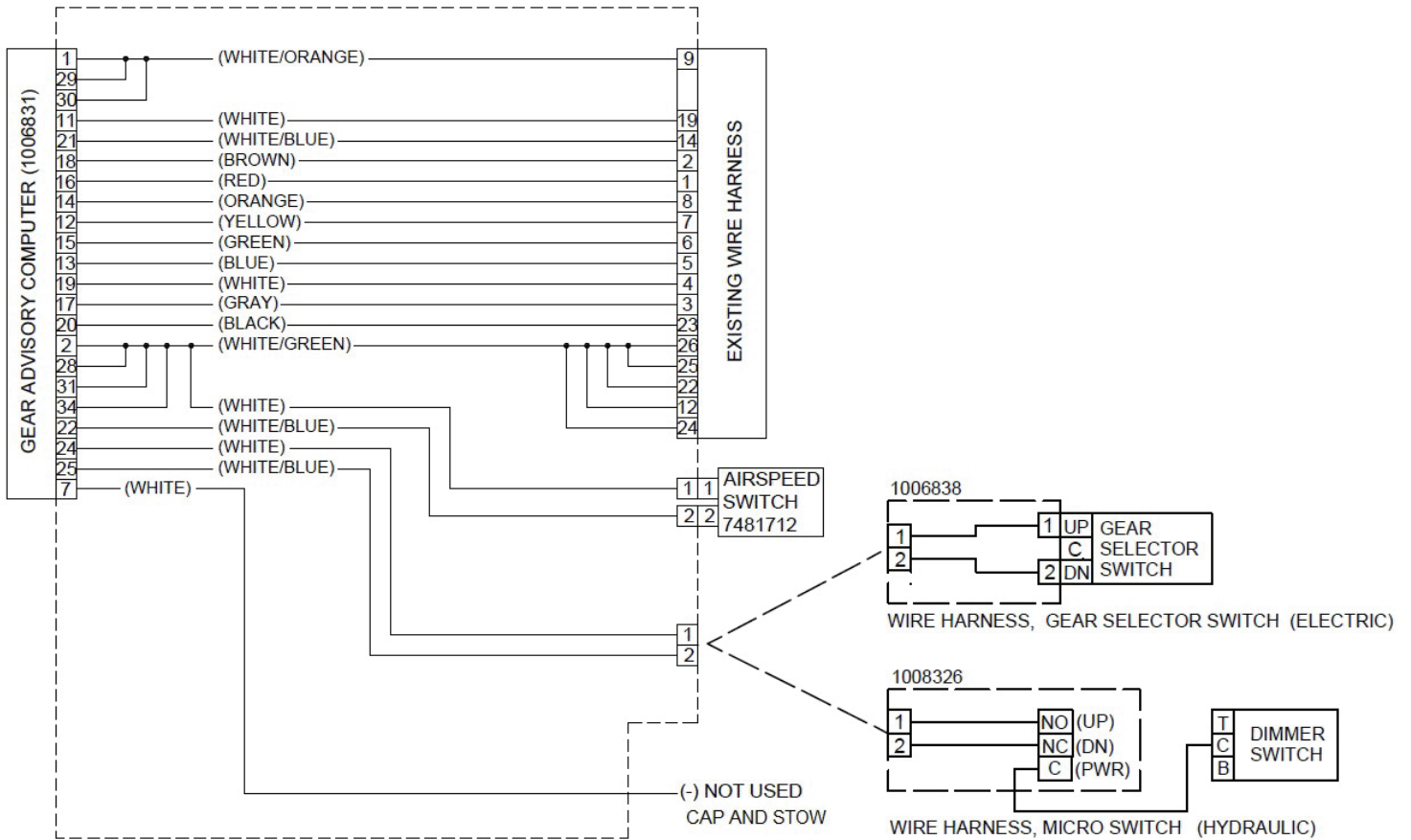

5. For aircraft with bi-directional hydraulic pumps, install 1006838 wire harness onto gear selector switch as shown in the following illustration..

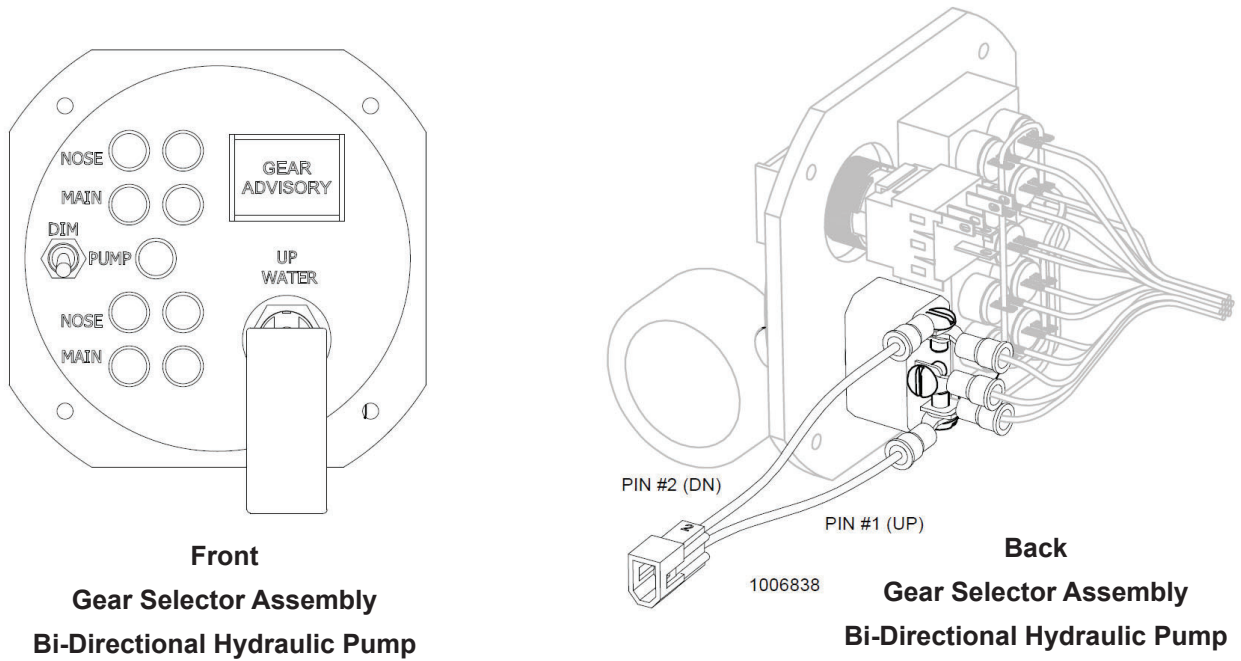

6. For aircraft with uni-directional hydraulic pumps, install micro switch harness 1008326 onto bracket 1008301. Remove spacer and bolt from gear selector assembly and install bracket onto gear selector assembly as shown. Route single wire from harness 1008326 and solder to middle spade of dimmer switch for 5 amp power. Route two pin plug from 1008326 with existing wire harness on gear selector assembly.

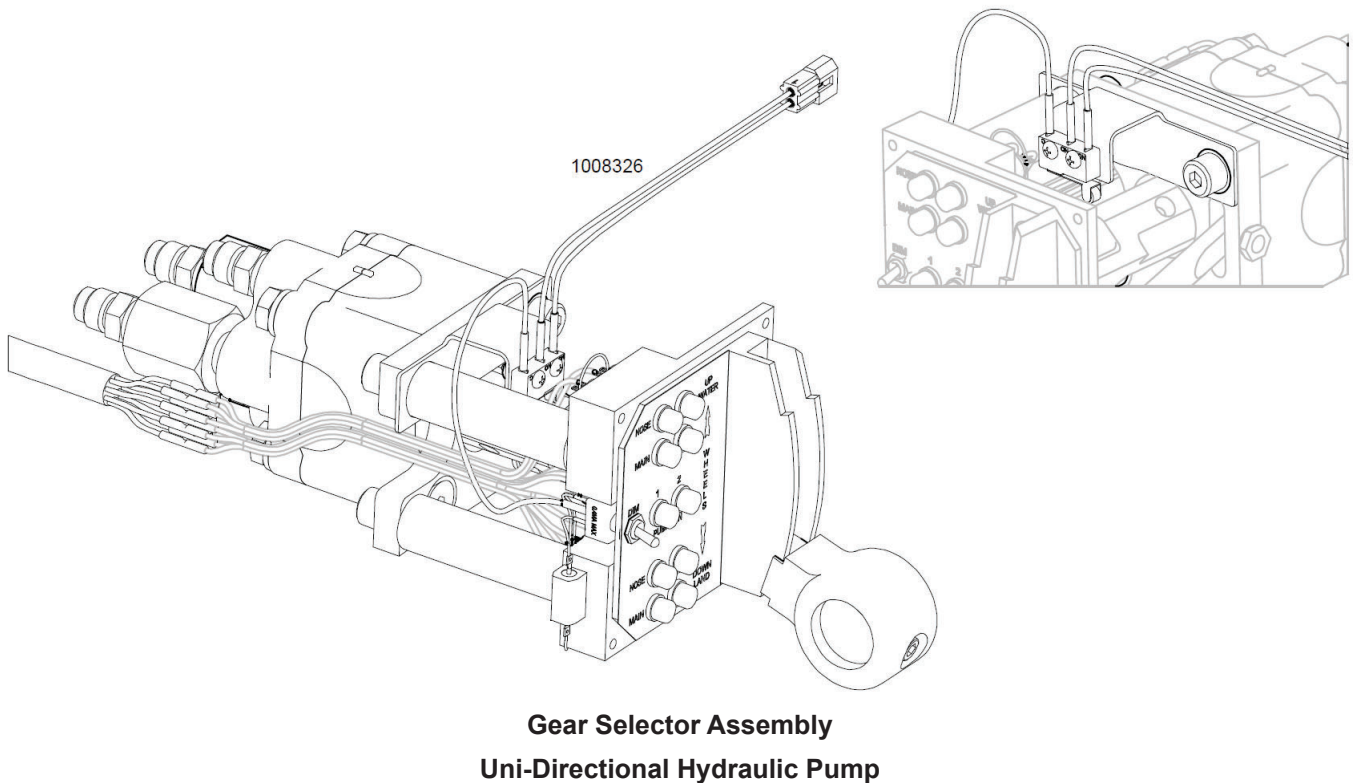

7. Route two pin plug from wire harness 1008291 to gear selector and connect plug with wire harness 1006838 or 1008326.
8. Replace bulb in amber push button switch with Light Bulb, 12V (330) for aircraft with 12 volt systems, or Light Bulb, 24V (327) for 24 volt electrical systems.
9. After checking all connections, apply power to the system. A self-test message will be heard within two minutes of startup. Wait 30 seconds then press and hold the annunciator switch for 2-3 seconds for a secondary test message.

**RECOMMENDED
GEAR ADVISORY SPEEDS**

MAKE/MODEL	KTS	MPH
CUB	65	75
HUSKY	65	75
SCOUT	65	75
C-170	75	86
C-172	75	86
C-172XP	75	86
LAKE	75	86
C-175	85	98
C-180	85	98
C-182	85	98
C-185	85	98
C-206	85	98
HELIO	85	98
BEAVER	85	98
REPUBLIC	85	98
GRUMMAN	95	109
MAULE	95	109
KODIAK	95	109
TWIN OTTER	95	109
AIR TRACTOR	95	109
C208/C208B	95	109

+/- 2 KTS / 2.3MPH

AIRCRAFT CLOSING AND RETURN TO SERVICE

1. Upon completion of inspection, enter information in Aircraft Logbook for completion of this Wipaire Service Letter.