



WIPLINE FLOATS • SKIS • MODIFICATIONS • AIRCRAFT SALES
AVIONICS • INTERIOR • MAINTENANCE • PAINT REFINISHING

SERVICE LETTER 205

10000A Hopper Fill Control System Replacement

Aircraft Makes/Model(s):	Float Model(s):	Compliance: Optional	By: MAB
Air Tractor AT-802 and AT-802A	10000A	Part Number: 1011407	Approved: SDW
		Date: 6/11/2021	Revision: E

LOG OF REVISIONS

Revision	Description	Date
A	Initial release	4/20/2020
B	Full rewrite	7/9/2020
C	Updated Trotter part numbers with Wipaire part numbers. Added Note and image about Figure 5. Updated schematic.	12/15/2020
D	Updated images in Figure 2 and Figure 5	3/15/2021
E	Added Work Instructions for optional adapter plate. Reworked Trotter installation section. Replaced Figure 2. Previous Figure 5 deleted, new Figure 5 used in adapter plate section.	6/11/2021

FAA approval has been obtained for technical data in this publication that affects STC or TSO design compliance.

EFFECTIVITY:

This service letter applies to Air Tractor models AT-802 and AT-802A with Wipline 10000A Floats, serial numbers 10227A & 10228A and prior, installed per STC SA01795CH.

COMPLIANCE:

Optional compliance

BACKGROUND:

The Amtech fill system has been discontinued. This service letter provides an option to replace it with a new Trotter Controls fill system. It also provides an option for installing an adapter plate which allows much of the modification for the Trotter conversion to be done ahead of time, while still keeping the Amtech sensor installed.

COMPLIANCE METHOD:

Install provided parts as shown in the Work Instruction section of this service letter.

APPROXIMATE SHOP HOURS:

The work instruction for full conversion to the new fill system will take approximately 10 labor hours.

WARRANTY INFORMATION:

This service letter does not include warranty for labor and parts.

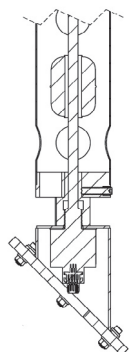
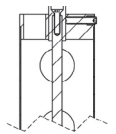



TECHNICAL DATA:

Copies of this service letter, associated service kit (if applicable), float service manual, and float parts manual are available at www.wipaire.com.

ITEMS PROVIDED IN SERVICE KIT 1011407-01 (AT-802A SINGLE PANEL DISPLAY)

ITEM	QTY	PART NUMBER	DESCRIPTION
1	1	1011618	FILL LEVEL DISPLAY, PILOT TROTTER MANUFACTURER P/N 5025-0032-04
2	1	1011750	WIRE HARNESS, FILL SYSTEM POWER TROTTER MANUFACTURER P/N 5825-0570
3	1	1011751	WIRE HARNESS, HOPPER FILL PROBE TROTTER MANUFACTURER P/N 5825-0571
4	1	1011752	WIRE HARNESS, FILL LEVEL RELAY TROTTER MANUFACTURER P/N 5825-0572
5	1	1011754	WIRE HARNESS, FILL LEVEL QTY TROTTER MANUFACTURER P/N 5825-0574
6	1	1011649	ASSEMBLY, PROBE, FILL SYSTEM TROTTER MANUFACTURER P/N 5850-0030
7	6	AN3C6A	BOLT, 10-32, 0.375 GRIP, UNDRILLED, STAINLESS STEEL
8	6	AN970C3	WASHER, LARGE AREA
9	6	MS21044C3	NUT, LOCKING, REGULAR HEIGHT, 10-32 UNF
10	1	7B3-4400-13	PLACARD, FILL LEVEL SET
11	1	7B3-4400-33	PLACARD, INCREASE
12	1	7B3-4400-34	PLACARD, DECREASE

ITEMS PROVIDED IN SERVICE KIT 1011407-02 (AT-802 FRONT & REAR PANEL DISPLAY)

ITEM	QTY	PART NUMBER	DESCRIPTION
1	1	1011755	FILL LEVEL DISPLAY, CO-PILOT TROTTER MANUFACTURER P/N 5025-0198
2	1	1011756	WIRE HARNESS, CO-PILOT FILL LEVEL TROTTER MANUFACTURER P/N 5825-0577
3	1	1011618	FILL LEVEL DISPLAY, PILOT TROTTER MANUFACTURER P/N 5025-0032-04
4	1	1011750	WIRE HARNESS, FILL SYSTEM POWER TROTTER MANUFACTURER P/N 5825-0570
5	1	1011751	WIRE HARNESS, HOPPER FILL PROBE TROTTER MANUFACTURER P/N 5825-0571
6	1	1011752	WIRE HARNESS, FILL LEVEL RELAY TROTTER MANUFACTURER P/N 5825-0572
7	1	1011754	WIRE HARNESS, FILL LEVEL QTY TROTTER MANUFACTURER P/N 5825-0574
8	1	1011649	ASSEMBLY, PROBE, FILL SYSTEM TROTTER MANUFACTURER P/N 5850-0030

9	6	AN3C6A	BOLT, 10-32, 0.375 GRIP, UNDRILLED, STAINLESS STEEL
10	6	AN970C3	WASHER, LARGE AREA
11	6	MS21044C3	NUT, LOCKING, REGULAR HEIGHT, 10-32 UNF
12	1	7B3-4400-13	PLACARD, FILL LEVEL SET
13	1	7B3-4400-33	PLACARD, INCREASE
14	1	7B3-4400-34	PLACARD, DECREASE

Work Instruction - Full Amtech To Trotter Conversion

Remove Amtech Fill System

1. Remove old (Amtech) fill sensor assembly and wiring from hopper.
 - a. Leave in the upper bracket (10A12251-006) bolted to the top of the hopper. Reference Figure 3.
 - b. Remove and discard the 4 bolts mounting the probe to the back wall of the hopper. Reference Figure 3.
 - c. Disconnect wiring harness at red connector behind panel in cockpit.
2. Remove old (Amtech) fill display screen and wiring from panel.
 - a. Disconnect yellow connector from rear of screen.
 - b. Disconnect 3 wire connector (P-17).
 - c. Remove adjustment knob.
3. Disconnect blue connector from rear of screen, one wire comes out of blue connector and goes to P-16/Pin 2. Cut this wire at butt splice.

Install Trotter Controls Fill System

1. Offwing, create the new fill sensor assembly as follows:
 - a. Remove and save the upper shield bracket, the shield, lower shield bracket, and set screws from the old fill probe assembly.
 - b. Discard the bottom tank mounting bracket and old fill probe/float.
 - c. Cut off 2" from the top of the 10A12665-001 shield. Deburr, prime and paint for corrosion protection. Reference Figure 1.

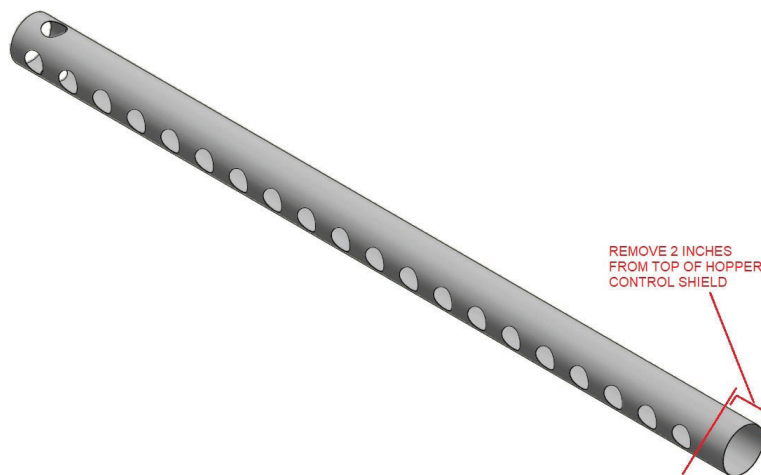

Figure 1 - 10A12665-001 Shield

- d. Reinstall the lower shield bracket, the modified shield, and upper shield bracket onto the new fill probe, p/n 1011649.
2. Open up the 4 existing 3/16" mounting holes in the rear wall of the hopper to 3/8". Reference Figure 2.
3. Cut between the 3/8" holes for a 2.13" x 2.13" access hole. This will give access to install the connector on the new probe. Reference Figure 2.
4. Fit the new probe into the top upper bracket (10A12251-006) and center the foot over the 2.13" x 2.13" access hole. Transfer the 6 mounting holes in the foot of the new probe into the rear wall of the hopper using #10 drill bit. Reference Figures 2 and 3.

Note: A locally fabricated template may be used to assist in locating holes. See Figure 2 for pertinent dimensions. The 4 existing mounting holes are recommended reference points, before cutting the square access hole.

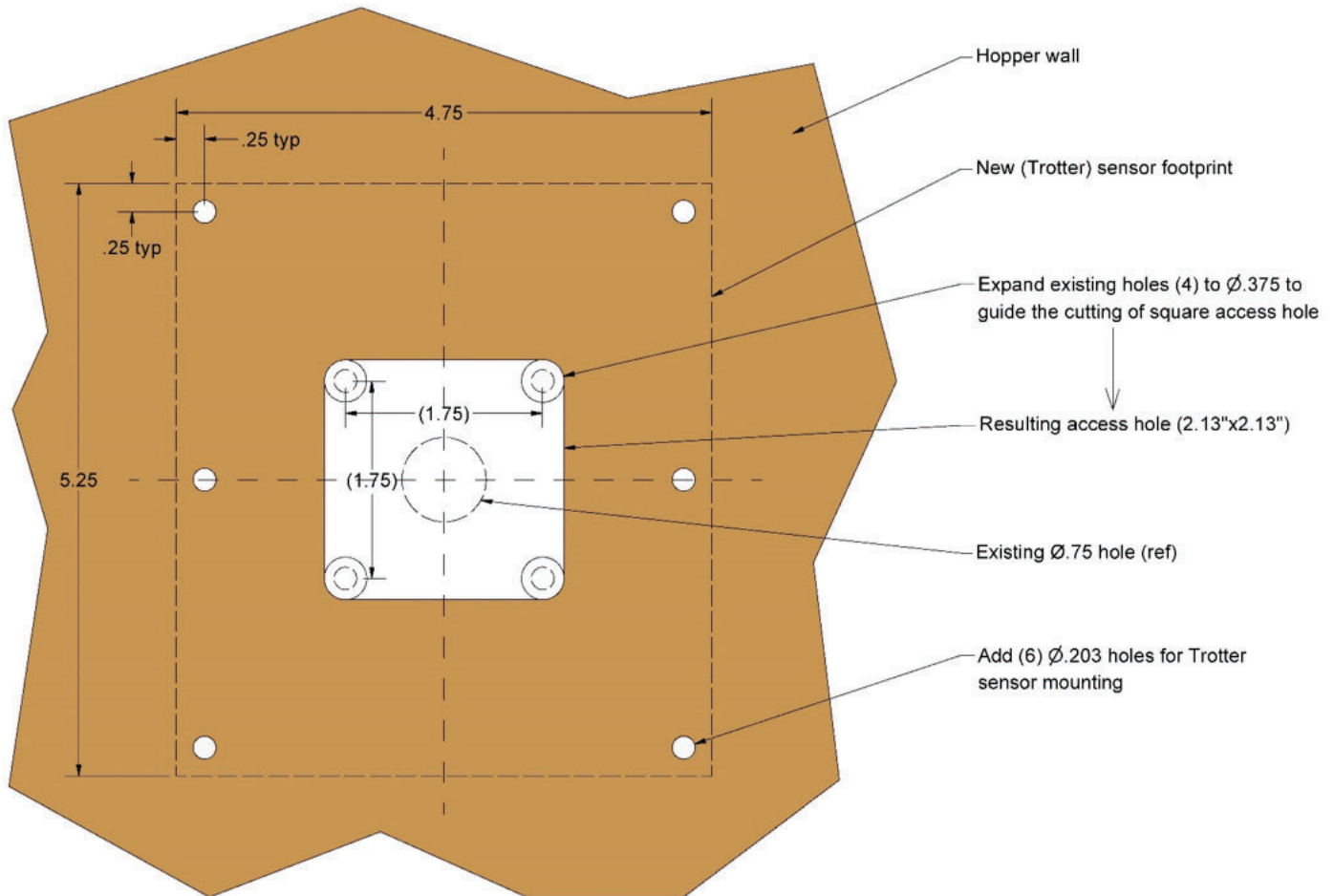

Figure 2 - Prepare the Bottom/Back of Hopper

5. Install with proseal and new hardware.

Note: Reference Figure 4 for steps 6-11:

6. Install cable PN 1011751 onto the probe and route through floor access boot into the cockpit and behind the panel.
7. Install the new display p/n 1011618 in the panel using existing screws. New display is longer than previous display. Adjust accordingly.
 - a. Connect PN 1011751 by connecting J20 to P20.
8. Install scoop qty. switch assy PN 1011754 in panel and connect P60 to J60.
 - a. Install placard PN 7B3-400-13 "Fill Level Set" next to switch.

- b. Install placard PN 7B3-4400-33 "Increase" above switch.
 - c. Install placard PN 7B3-4400-34 "Decrease" below switch.
9. Install harness PN 1011752 by connecting J30 to P30.
- a. The white wire in this harness connects to the scoop relay P16/Pin 2 with a butt splice.
10. Install harness PN 1011750 by connecting J10 to P10.
- a. The other end plugs into P-17.
11. If installing in a dual cockpit with a rear instrument panel the rear display kit is optional, see P/N 1011755 Copilot Fill Level Display and P/N 1011756 Wire Harness for Copilot Fill Level.

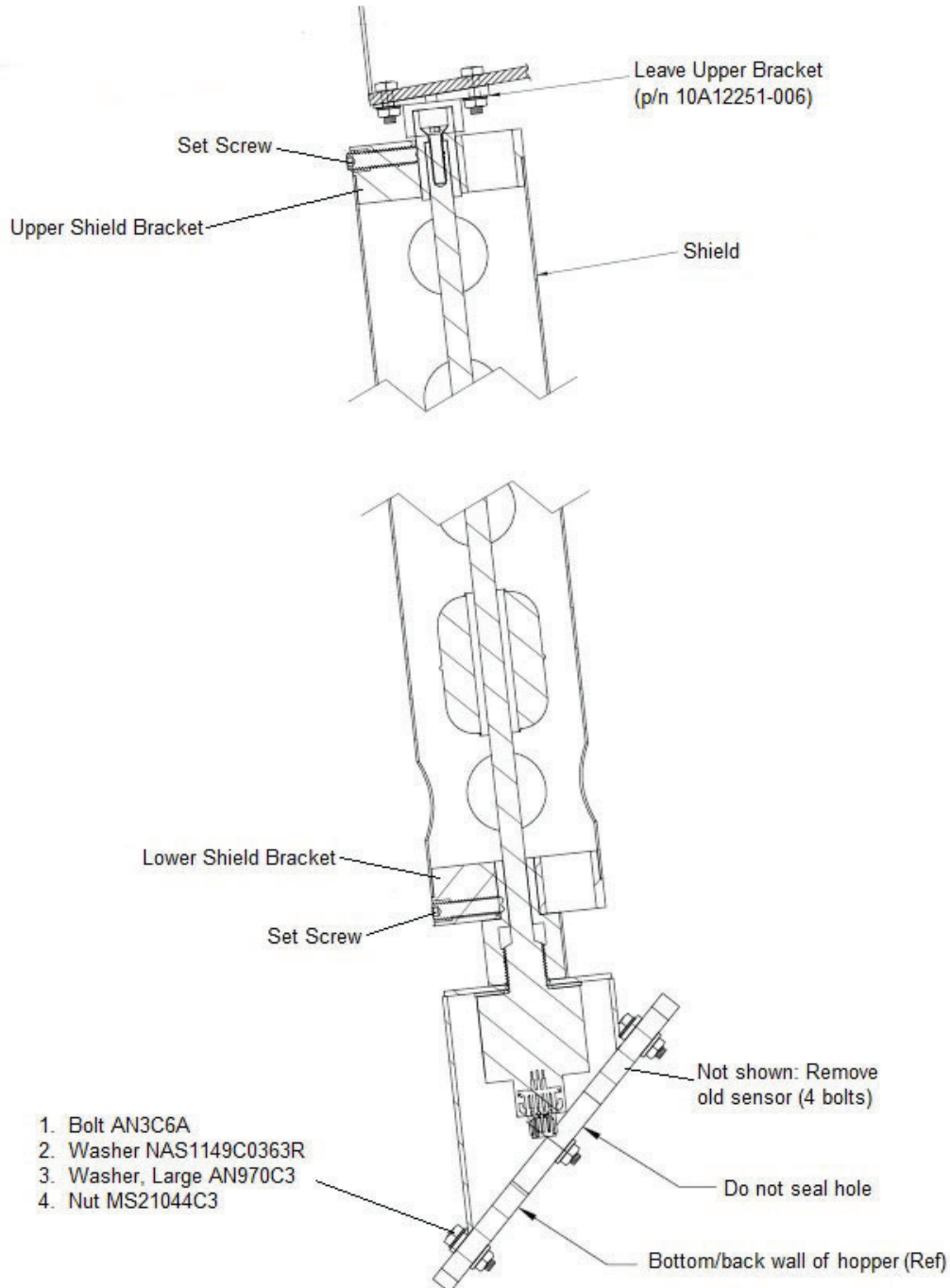

Figure 3

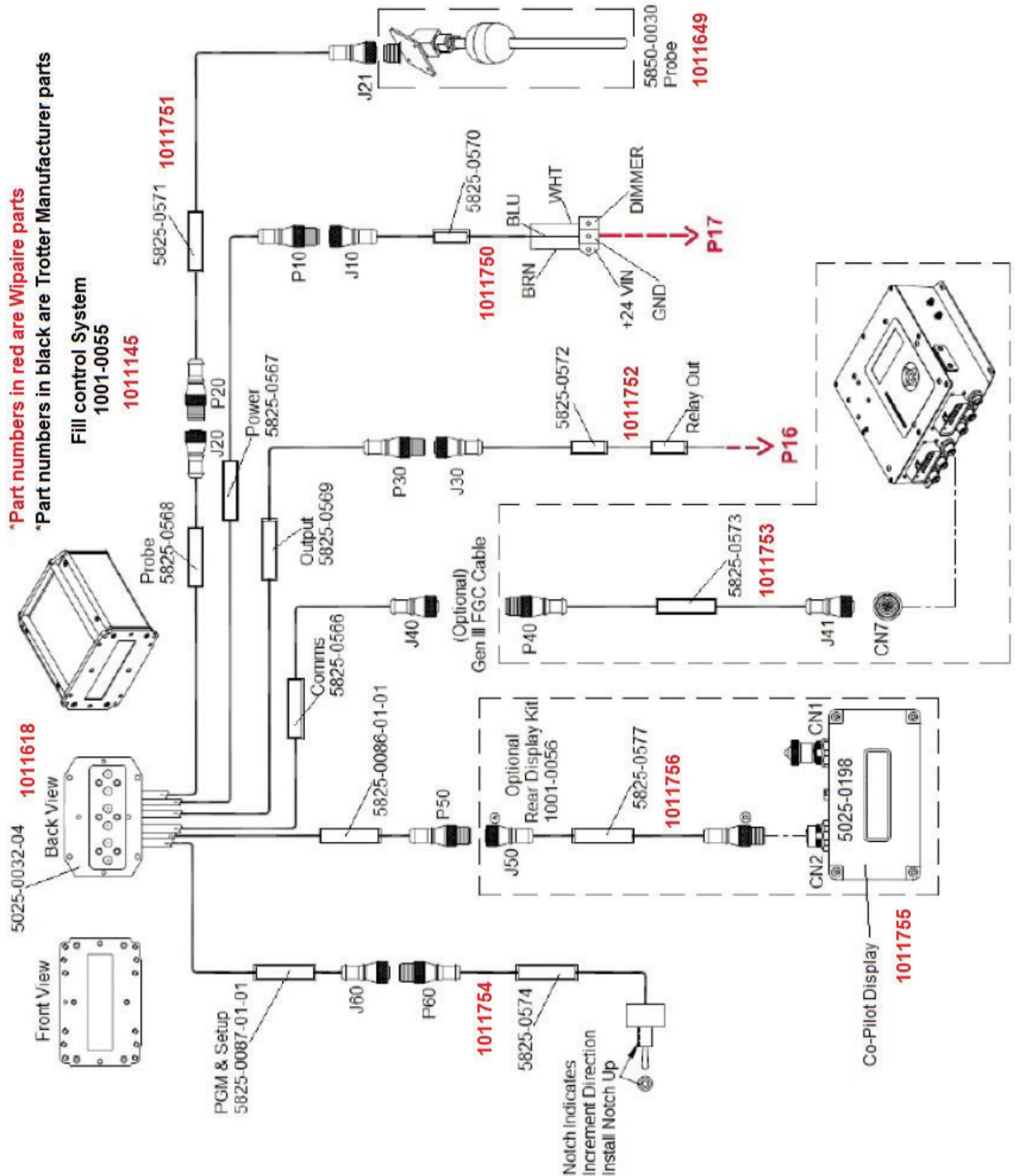

Figure 4 - New Fill System Schematic

Screen Display Check Out

1. Put power on the system. System is powered by a 1-amp breaker "Scoop System."
2. Select scoop switch to "Scoops Manual" and the screen display should come on.
3. Select scoop switch to "Off" and the screen display should power off.
4. Select scoop switch to "Scoops Auto" and the screen display should come back on.
5. Turn on "Inst. and Flap Lights" switch.
6. With upper panel dimmer switch the screen display should dim with the rest of the lights.
7. Turn off "Inst. and Flap Lights" switch and screen should go back to full bright.
8. Hopper level is the top number on the display and should read zero gallons. A reading of 195+-5 gallons is acceptable. The probe is calibrated to start reading just under 200 gallons.
9. The "Fill To" level should read 600 gallons. This is factory set.
10. Using the fill level switch the "Fill To" level should increase by 25 gallon increments up to 800 gallons and decrease by 25 gallon increments down to 300 gallons.

Manual Scoop System Check Out

1. Select scoop switch to "Scoops Manual."
2. Select "Fill To" level to 300 gallons.
3. Deploy scoops using switch on stick and hold scoops down. Verify "Scoops Down" light.
4. From inside the hopper move the float ball up slowly.
5. Once the hopper level reaches 300 gallons the scoops should stay down.
6. Release scoop stick on switch. Verify "Scoops Up" light.

Auto Scoop System Check Out

1. Select scoop switch to "Scoops Auto."
2. Select "Fill To" level to 300 gallons.
3. Deploy scoops using switch on stick and hold scoops down. Verify "Scoops Down" light.
4. From inside the hopper move the float ball up slowly.
5. Once the hopper level reaches 250 gallons the scoops will automatically retract. Verify "Scoops Up" light. Release scoop switch on stick.
6. Select "Fill To" level to 400 gallons.
7. Deploy scoops using switch on stick and hold scoops down. Verify "Scoops Down" light.
8. From inside the hopper move the float ball up slowly.
9. Once the hopper level reaches 350 gallons the scoops will automatically retract. Verify "Scoops Up" light. Release scoop switch on stick.
10. Continue checks up to 800 Gallons.
11. System checks complete.

Work Instruction – Interim Adapter Plate

Note: Performing these steps allows hopper modifications for new (Trotter) fill system to be performed ahead of time while continuing to operate the old (Amtech) system, if serviceable.

1. Temporarily dismount Amtech fill sensor.
2. Locally fabricate adapter plate matching the new (Trotter) footprint and containing the center $\frac{3}{4}$ " hole as well as the 6 new mount holes for the Trotter sensor. Reference Figure 2. Plate to be made from 0.070" stainless steel, grade 301, 304, or 316.
 - a. Match drill the 4 holes for mounting the Amtech sensor into the adapter plate. Reference Figure 5.
 - b. Match drill the 6 outer holes from the adapter plate into bottom/back wall of the hopper. Reference Figure 5.
3. Expand the 4 Amtech mounting holes in the hopper wall to $\frac{3}{8}$ ". Reference Figure 2.
4. Cut between the newly expanded $\frac{3}{8}$ " holes to create a square access hole. Reference Figure 2. When the new (Trotter) sensor is installed, this will provide access to install the connector.
5. Install Adapter Plate and re-install Amtech sensor using proseal and new hardware. Reference Figure 5.

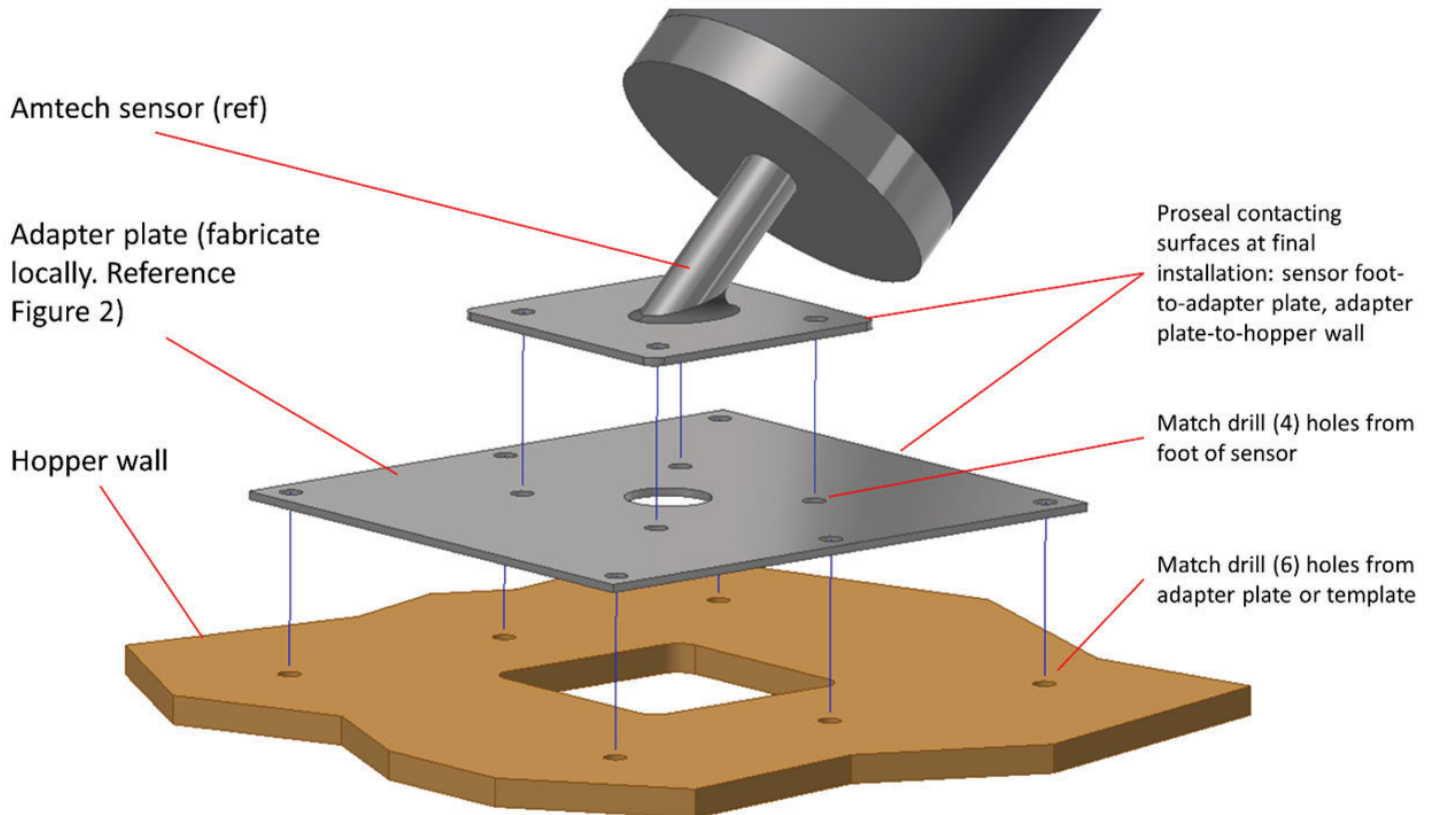

Figure 5 - Adapter Plate Installation

Aircraft Closing & Return to Service

1. Upon completion of inspection, enter information in Aircraft Logbook for completion of Wipaire Service Letter 205. Note partial completion if only the hopper wall modification and adapter plate steps are performed and Amtech sensor reinstalled.