



WIPLINE FLOATS • SKIS • MODIFICATIONS • AIRCRAFT SALES
AVIONICS • INTERIOR • MAINTENANCE • PAINT REFINISHING

SERVICE LETTER 258

AT-802 & AT-802A on 10000A Floats – Fire Boss Ferry Fuel System

Aircraft Makes/Model(s):	Float Model(s):	Compliance: Optional	By: MAS
Air Tractor AT-802 & AT-802A	10000A	Part Number: 1012414	Approved: DRH
		Date: 12/7/2023	Revision: A

LOG OF REVISIONS

Revision	Description	Date
A	Initial release	12/7/2023

FAA approval has been obtained for technical data in this publication that affects STC or TSO design compliance.

EFFECTIVITY:

This service letter applies to Air Tractor models AT-802 and AT-802A with Wipline 10000 Floats installed per STC SA1795CH.

COMPLIANCE:

Compliance is optional.

BACKGROUND:

Conversion of the hopper and fire system to support extended range fuel storage for ferry flights. This service letter accompanies Air Tractor Service Letter 219 and Air Tractor print 50280. This letter does not provide instructions for Air Tractor Service Letter 219 and Air Tractor print 50280.

COMPLIANCE METHOD:

Clean out hopper and seal plumbing for fire system. Aircraft must comply with this service letter and all Air Tractor documentation for the installation of Ferry Fuel conversion kit including Air Tractor print 50280 and Air Tractor Service Letter 219.

APPROXIMATE SHOP HOURS:

Performing the work instructions will take approximately 6 labor hours to complete.

WARRANTY INFORMATION:

This service letter does not include warranty for labor and parts.

TECHNICAL DATA:

Copies of this service letter, associated service kit (if applicable), float service manual, and float parts manual are available by contacting Wipaire customer service.

ITEMS PROVIDED IN SERVICE KIT 1012414-01 (1 KIT PER AIRCRAFT)			
ITEM	QTY	PART NUMBER	DESCRIPTION
1	2	10A18000-004	PLUG FOR FILL TUBES
2	2	10A12697-001	HOSE COUPLING
3	4	5312K16	POWER CLAMPS
4	1	10A18000-005	PLUG FOR HOPPER VENT
5	1	10A12696-001	HOSE COUPLING
6	2	5312K18	POWER CLAMP
7	1	R581559	43" REPLACEMENT SEAL
8	1	80532-5	140" REPLACEMENT SEAL
9	1	1300L-5OZ	GLUE

TABLE 1

Work Instructions

Installation

Note: All reference items in these instructions see table 1.

Note: Leak check hopper for leaks and correct leaks before installation of the hopper ferry kit.

1. Position and prepare aircraft for safe maintenance.
2. Verify the gear is in the desired position for maintenance.
3. Turn Master Switch to the "ON" position.
4. Turn the Fire Retardant Delivery System (FRDS) to the "ON" position.
5. Open the FRDS hopper doors.
6. Pull out the FRDS circuit breaker.
7. Turn the Master Switch to the "OFF" position.
8. Open the hopper lid and secure open as needed.

Note: Procedures on opening the hopper lid will vary depending on what FRDS is installed. See the appropriate documents for the installed FRDS.

9. Thoroughly rinse out hopper and wipe down all surfaces to remove any debris from the hopper.
10. Etch plugs (items 1 & 4) if not already accomplished. (See Figure 1).

"FERRY OPERATION ONLY"

"REMOVAL: LOWER CLAMP"

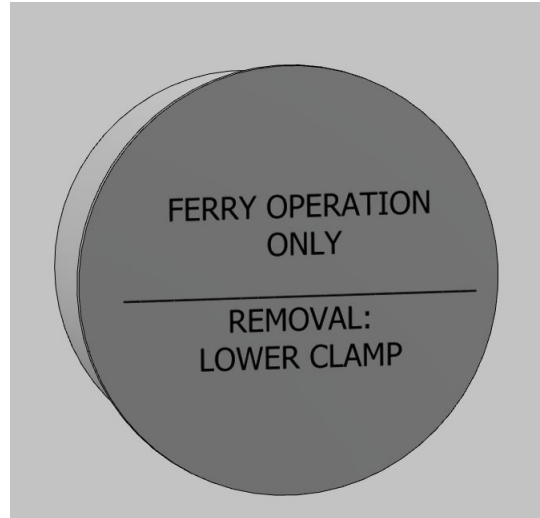

Figure 1 - Etched Cap, 10A18000-004 & 10A18000-005

11. Remove forward and aft platypus valves. If safety straps are installed, then disconnect the safety straps from the studs mounted to the fill tube. Leave studs sealed in fill tube. (See Figure 2).

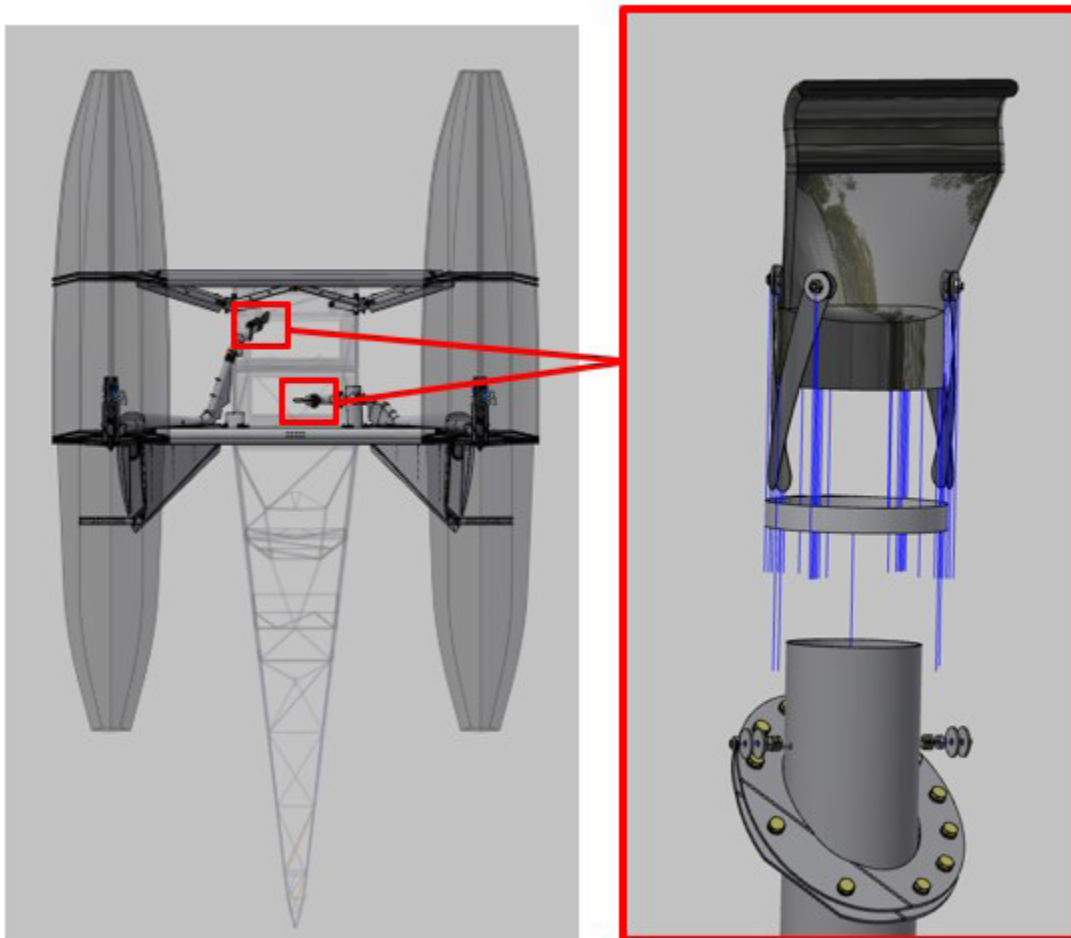

Figure 2 - Platypus Valve Removal

12. Pre-assemble the plug (item 1) into the hose coupling (item 2) using pro-seal with bolt hose clamp (item 3) to make 2 assemblies. Install the assembly onto the forward and aft fill tubes using pro-seal during the installation. (See Figure 3).

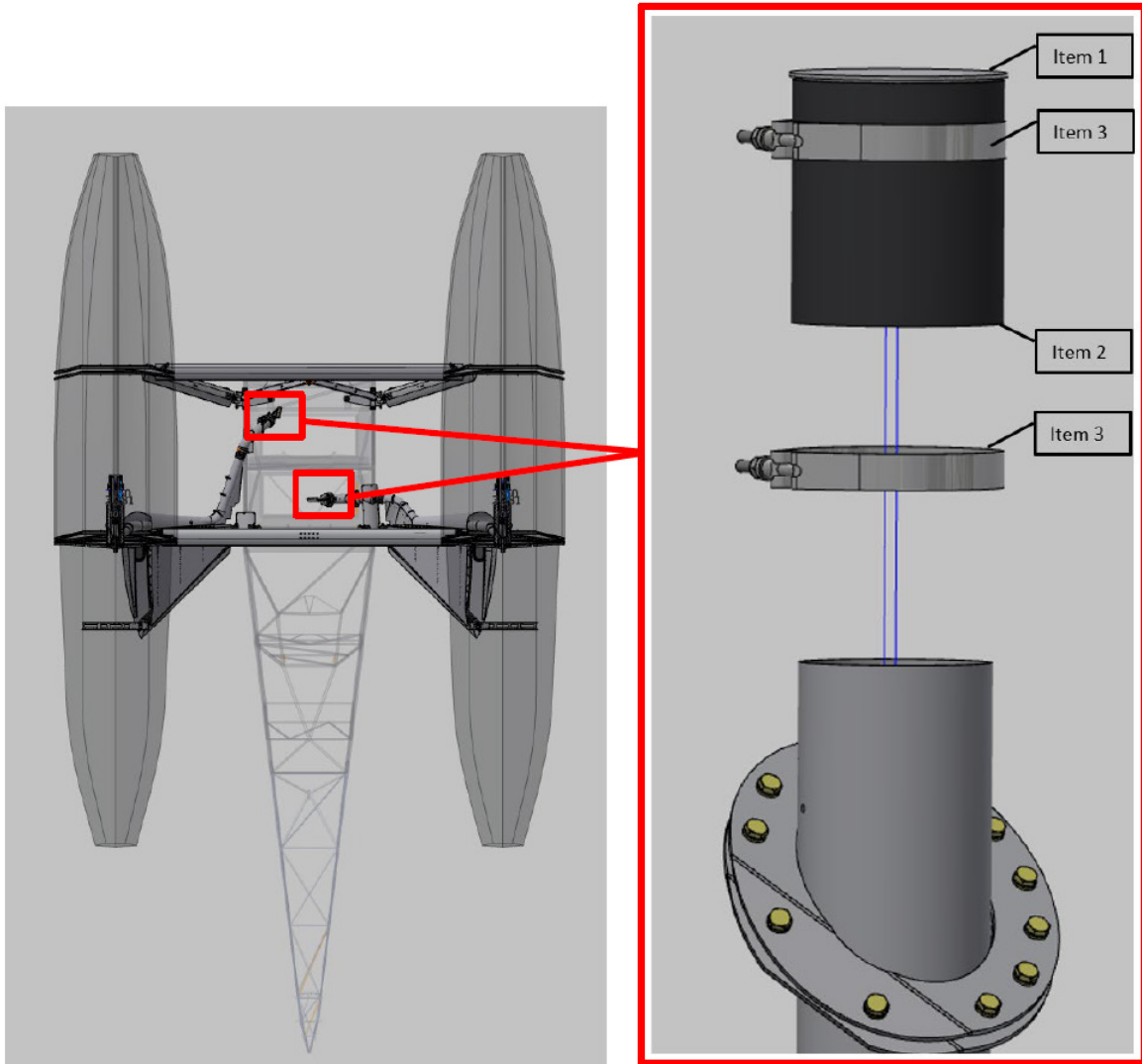

Figure 3 - Plug Assembly

13. Remove vent ball stop screw and associated hardware from the Air Tractor factory hopper vent. (See Figure 4).



Item	Part Number	Description
34	AN526C1032R18	TRUSS HEAD SCREW
43	MS21044C3	10-32 LOCKING NUT
53	NAS1149C0363R	0.203ID, 0.063THK, WASHER

Figure 4 - Vent Tube Retainer

14. Pre-assemble the plug (item 4) into the hose coupling (item 5) using pro-seal with bolt hose clamp (item 6) to make assembly. Install the assembly from the previous step onto the vertical vent pipe using pro-seal during the installation. (See Figure 5).

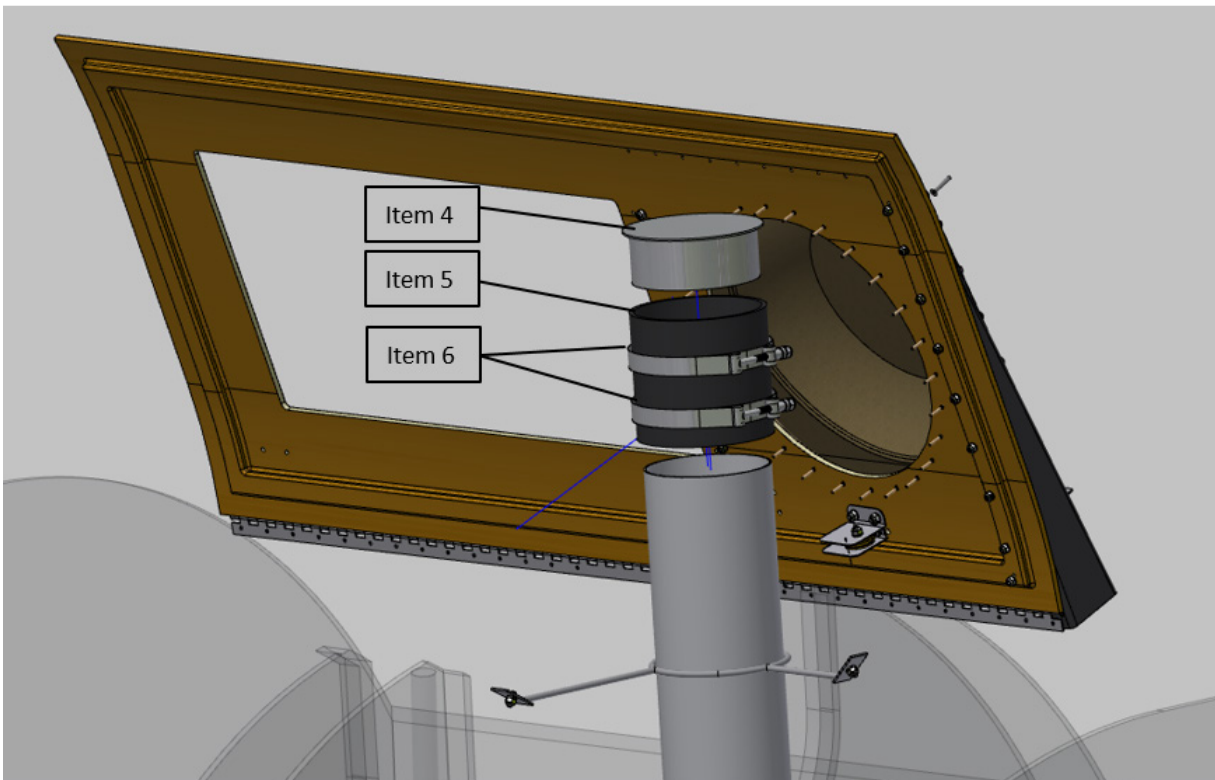

Figure 5 - Plug Installation on Hopper Vent

15. Remove the hopper ground fill system to the hopper coupler. Reference Wipaire Print 1003388.
 - a. Remove the valve with the rubber coupling and support bar that is attached to the aft spreader bar.
 - b. Remove aft FRDS fairing.
 - c. Disconnect any support brackets and remove the fill tube to the hopper.

Note: See the appropriate installation or service documentation for the ground fill system that is installed.

16. Install Air Tractor Provisions.
17. Lightly grease hopper lid and firegate door seals per the FRDS service documents.
18. Close the hopper lid and secure.
19. Reassemble all previously removed FRDS parts if removed to open the hopper lid.
20. Verify the gear is in the desired position for maintenance.
21. Turn Master Switch to the “ON” position.
22. Push in the FRDS circuit breaker.
23. Turn the FRDS to the “ON” position.
24. Close the FRDS hopper doors.
25. Turn the Master Switch to the “OFF” position.
26. Pull out and safety the FRDS circuit breaker.
27. Degrease hopper lid door edges and hopper overflow vent and seal with pro seal.
28. Box up removed parts and put in float baggage compartment. Include Ferry Fuel System removal instructions.

Removal

Note: All reference items in these instructions see table 1.

1. Position and prepare aircraft for safe maintenance.
2. Verify the gear is in the desired position for maintenance.
3. Remove any sealant added to the hopper lid.
4. Defuel the hopper as needed.
5. Turn Master Switch to the “ON” position.
6. Remove the safety on the FRDS circuit breaker and push in the circuit breaker.
7. Turn the FRDS to the “ON” position. Open the FRDS hopper doors.
8. Pull out the FRDS circuit breaker.
9. Turn the Master Switch to the “OFF” position.
10. Open the hopper lid and secure open as needed.

Note: Procedures on opening the hopper lid will vary depending on what FRDS is installed. See the appropriate documents for the installed FRDS.

11. Thoroughly rinse out hopper and wipe down all surfaces to remove any debris from the hopper.
12. Remove the forward and aft fill tube caps from the rubber coupler side. (See Figure 3).
13. Install forward and aft platypus valves and safety by either: (See Wipaire Service Letter 235). (See Figure 2).
 - a. If safety straps are installed, then reconnect the 4 safety straps per valve to the studs mounted to the fill tube.
 - b. If safety wire is installed, install safety wire from stud to stud on each side of valve. (Recommend .040” safety wire).
14. Install vent ball stop screw and associated hardware. (See Figure 4).
15. Remove the vertical vent pipe cap from the rubber coupler side. (See Figure 5).

16. Remove Air Tractor Provisions.
17. Install the hopper ground fill system to the hopper coupler. Removal of Air Tractor fuel system provisions must be removed prior to this step.
Note: See the appropriate installation or service documentation for the ground fill system that is installed.
18. Lightly grease hopper lid and firegate door seals per the FRDS service documents.
19. Close the hopper lid and secure.
20. Reassemble all previously removed FRDS parts if removed to open the hopper lid.
21. Inspect FRDS per the appropriate service documents.
22. Verify the gear is in the desired position for maintenance.
23. Turn Master Switch to the “ON” position.
24. Push in the FRDS circuit breaker. Turn the FRDS to the “ON” position.
25. Close the FRDS hopper doors.
26. Perform all operational checks of the FRDS per the appropriate operational and service documents.
27. Turn the Master Switch to the “OFF” position.

Aircraft Closing & Return to Service

1. Upon completion of inspection, enter information in Aircraft Logbook for completion of Wipaire Service Letter 258.