



WIPLINE FLOATS • SKIS • MODIFICATIONS • AIRCRAFT SALES
AVIONICS • INTERIOR • MAINTENANCE • PAINT REFINISHING

SERVICE LETTER 266

MVP-50T Installs on Fire Boss

Aircraft Makes/Model(s):	Float Model(s):	Compliance: Mandatory	By: MAS
Air Tractor AT-802 & AT-802A	Wipaire Fire Boss Conversion (10000A Floats & Landplane)	Part Number: 1012636	Approved: DRH
		Date: 1/6/2025	Revision: B

LOG OF REVISIONS

Revision	Description	Date
A	Initial release	10/28/2024
B	Full rewrite of service letter.	1/6/2025

FAA approval has been obtained for technical data in this publication that affects STC or TSO design compliance.

EFFECTIVITY:

This service letter applies to Air Tractor models AT-802 & AT-802A with Wipline 10000 amphibian floats and Fire Boss converted landplanes installed per STC SA01795CH with an MVP-50T installed.

COMPLIANCE:

Mandatory compliance

BACKGROUND:

Fire Boss converted AT-802 and AT-802A aircraft per STC SA01795CH have implemented engine audible and visible annunciations. This annunciation is activated when the engine torque and ITT parameters exceed their red line values. These values are configured according to the engine variant. Newly manufactured AT-802 and 802A aircraft can be equipped with the Electronics International MVP-50T. The installation of the MVP-50T eliminates the appropriate ITT connection point for the Wipaire installed engine annunciation in lieu of MVP-50T ITT exceedance visual annunciations.

To maintain the same level of annunciation between aircraft with and without the MVP-50T, the audio capabilities of the MVP-50T must be installed and enabled to allow for audio alerts for ITT and torque exceedance. This service letter describes the procedures for enabling this functionality on the MVP-50T. This service letter also removes the associated visual annunciation installed per STC SA01795CH as that functionality is provided by the MVP-50T Master Warning and Caution Lights.

COMPLIANCE METHOD:

Configure the audio annunciations for the MVP-50T as described in the work instructions of this service letter.

1700 Henry Ave - Fleming Field (KSGS), South St. Paul, MN 55075

Phone: 651.451.1205 | Fax: 651.457.7858

www.wipaire.com



APPROXIMATE SHOP HOURS:

The following breakdown shows approximate shop hours for each phase of instructions.

Shop Hours	
Task	Hours
Part A	2
Part B	8
Part C	2
Total hours	12

WARRANTY INFORMATION:

This service letter includes warranty for parts provided by Wipaire. Contact Wipaire customer support for labor considerations.

TECHNICAL DATA:

Copies of this service letter, associated service kit (if applicable), float service manual, and float parts manual are available at www.wipaire.com.

HARDWARE UPDATE:

Older models of the MVP-50T (Serial numbers 190500 and prior) will require a software update to enable audio functions. Please contact Electronics International with unit serial number and Hardware ID to determine upgrade applicability. Electronics International will be responsible for performing these upgrades. The following work instructions will only cover procedures with an MVP-50T unit that has been updated with audio capability.

ELECTRONICS INTERNATIONAL CONTACT INFORMATION

David Primmer

Electronics International

Support@iFlyEi.com

(541) 318-6060

KIT CONFIGURATIONS	
KIT NUMBER	DESCRIPTION
1012636-01	MVP-50T AUDIO UPDATE KIT, AT802A SINGLE SEAT
1012636-02	MVP-50T AUDIO UPDATE KIT, AT802 DUAL SEAT

ITEMS PROVIDED IN SERVICE KIT				
ITEM	QTY -01	QTY -02	PART NUMBER	DESCRIPTION
1	5 FT	5 FT	27500-22TG1T14	22 AWG SINGLE CONDUCTOR, SHEILDLED WIRE
2	3 FT	3 FT	22759-16-22-9	WIRE, 22 AWG, WHITE
3	4	4	205089-1	D-SUB CONN PIN, 20-34 AWG GOLD CRIMP
4	2	2	02-06-2103	MOLEX CONN PIN, 18-24 AWG CRIMP TIN
5	1 FT	1 FT	3635W-1/8-0	HEAT SHRINK, ADHESION LINED, 1/8 IN
6	1	2	PGM-3	NYLON BLACK, HOLE PLUG 0.468"
7	1	2	7B3-4400-26	PLACARD, ASYMETRICAL SCOOP
8	1	2	7B3-4400-15	PLACARD, WATER IN FLOAT
9	1	1	A208SYCB04	MOMENTARY SWITCH
10	1	1	1012707	PLACARD, ACKNOWLEDGE
11	1	1	1012708	PLACARD, VOICE ALARM
12	1	1	1012709	AUDIO FILE (CONTACT WIPAIRE CUSTOMER SUPPORT)

REQUIRED TOOLS AND CONSUMABLES	
ITEM	DESCRIPTION
1	SOLDERING IRON
2	PHILLIPS HEAD DRIVER
3	DRILL WITH ¼" DRILL BIT
4	SOLDER
5	HEAT GUN
6	WIRE CUTTER/WIRE STRIPPER
7	D-SUB PIN REMOVAL TOOL*
8	AD-1377 OR SIMILAR SPECIFIED CRIMP TOOL
9	D-SUB CRIMP TOOL
10	MOLEX CRIMP TOOL

*Optional equipment

Work Instructions Part A – Removing Old Annunciations

Work Instruction Notes:

Removal of the aural and visual annunciations from the Wipaire installed systems is required when utilizing the aural and visual annunciations from the MVP-50T.

For ease of access for all work instructions, remove the top panel of the glare shield.



1. Locate the PRD-60 voice annunciation box.

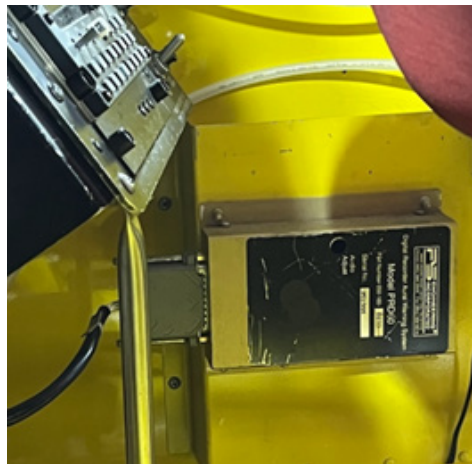

2. Disconnect the 25 pin D-Sub connector from the PRD-60 voice annunciation box and locate the Check Engine Power input, pin 10.

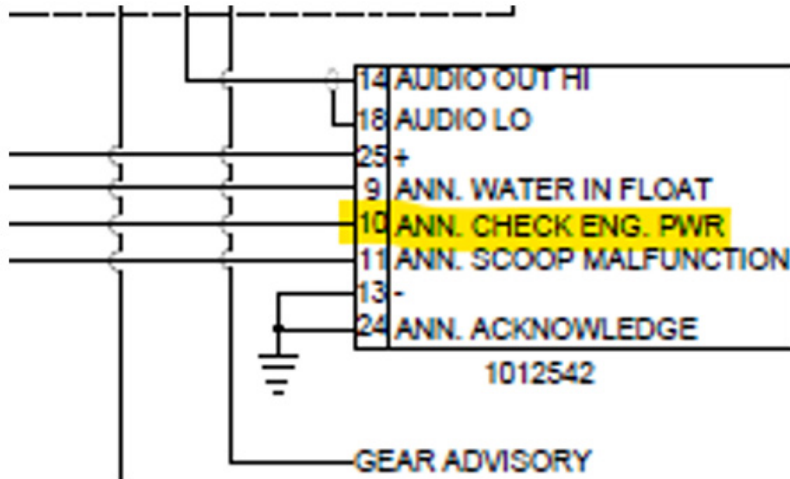

3. Using a D-Sub pin removal tool, remove the Check Engine Power pin from the D-Sub connector. Once removed, properly cap and stow the wire. If a pin removal tool is not available, cut the wire and properly cap and stow both ends.

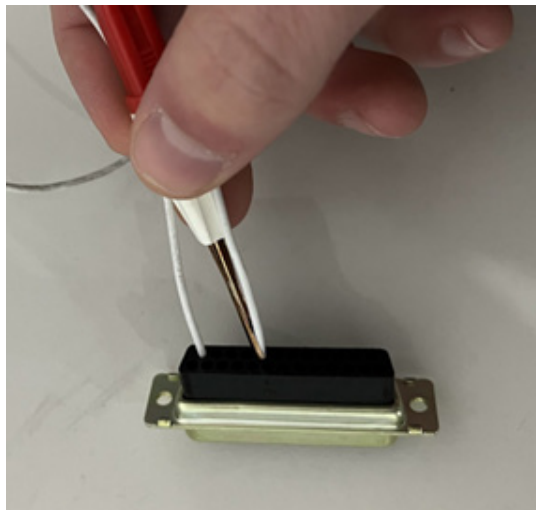

4. Locate the Engine Power light on the aircraft panel.



5. From the backside of the light, undo the connector on the wire tail labeled “EXCESS POWER”. Remove the nut on the backside of the light and remove the light assembly with the wire tail.



6. Properly stow the opposite wire lead. Place the nylon hole plug (Item 6) in place of the light assembly. Remove the ENGINE POWER placard and replace it with the new placards (Item 7, Item 8).



7. For AT802 two seaters, repeat steps 4-6 with the backseat panel.

Work Instructions Part B – Wiring and Installation

Work Instruction Notes:

Reference the following wire schematic for the following instructions.

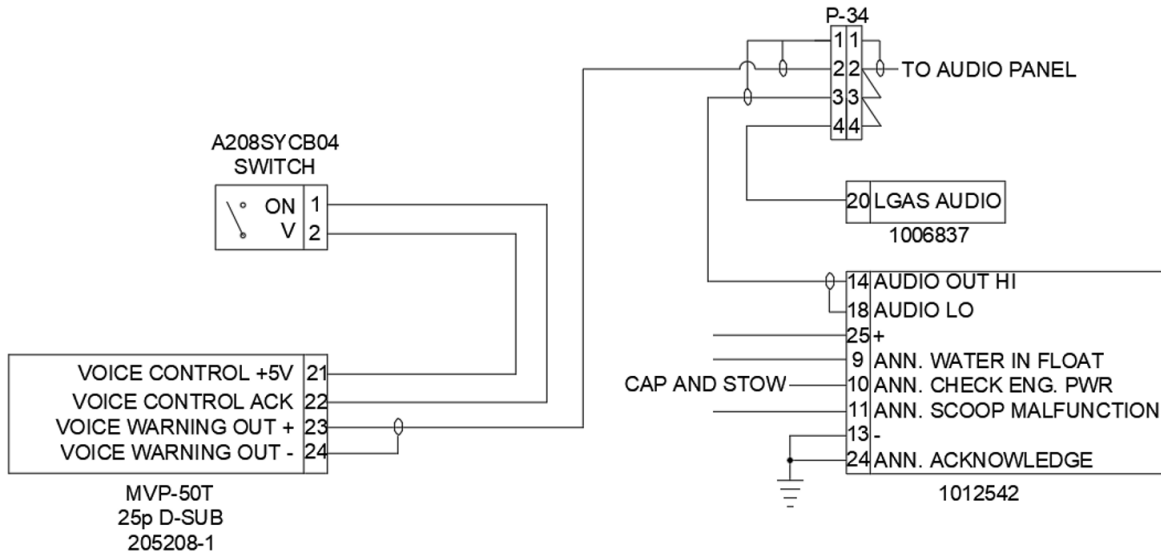

1. Locate and remove the MVP-50T 25 pin D-sub connector. For ease of access, it may be beneficial to remove the MVP-50T display from the panel by removing the four Philips head screws that secure the display to the panel.

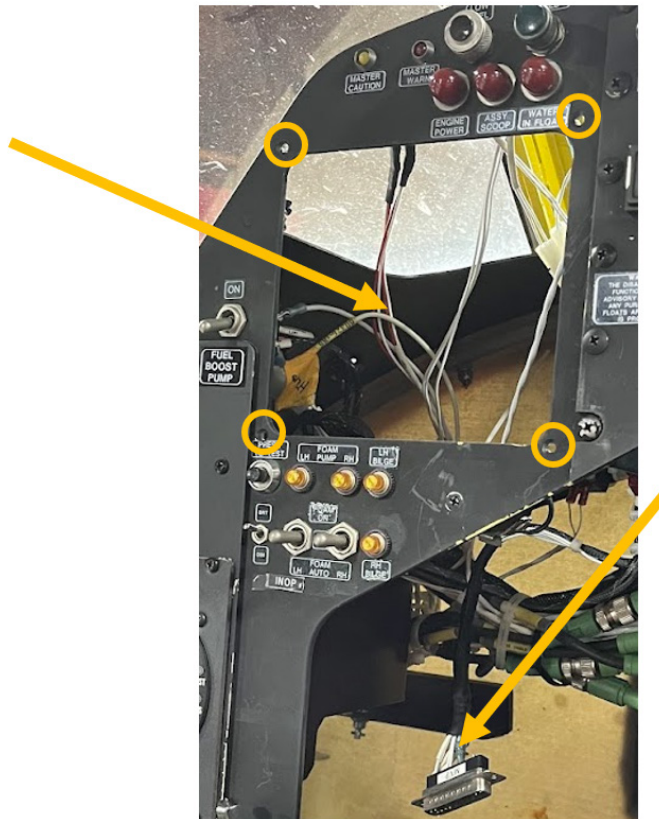

2. Unless already installed, wire the Voice Warning Out + (pin 23) into the MVP-50T D-sub connector using a male D-sub pins (Item 3) and shielded wire (Item 1, cut to length). Wire the Voice Warning Out – (pin 24) to the wire shield. (See wiring schematic)
3. Using the provided Molex crimp (Item 4), wire the Voice Warning Out + wire from the MVP-50T into the open pin 2 position on the P34 connector. Both the PRD60 and Wipaire LGAS will have audio outputs going to the same connector. Crimp the wire shield from the PRD60 and MVP-50T together and insert into position 1 on P34. (See wiring schematic)
4. Using 22AWG wire, (Item 2, cut to length) solder the audio acknowledge pins 21 and 22 to pins 1 and 2 on the provided momentary switch (Item 9). Use the heat shrink (Item 5, cut to length) to secure the wires to the switch.

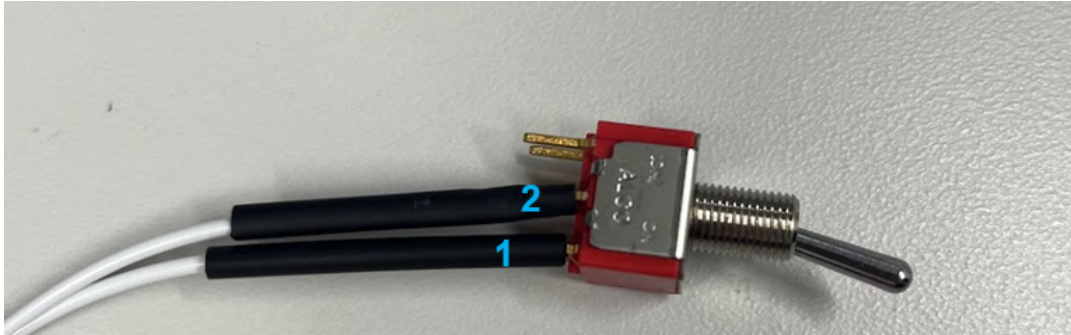

5. Near the Master Caution or Master Warn light, locate a space to install the supplied momentary switch and placards. Ensure ample space to install both switch and placards in proper orientation. Drill a 1/4-inch hole and install the switch with the provided hardware.



6. Install the “VOICE ALARM” and “ACK” placards (Item 10, Item 11) as shown in the image below.



Work Instructions Part C – MVP-50T Audio Configuration

Work Instruction Notes:

Contact Electronics International prior to these instructions to request a second level passcode.

David Primmer

Electronics International

Support@iFlyEi.com

(541) 318-6060

1. Insert the USB flash drive (Item 12) in the USB port on the front of the MVP-50T. Power on the MVP-50T and navigate to the settings menu by pressing the “Menu” button.

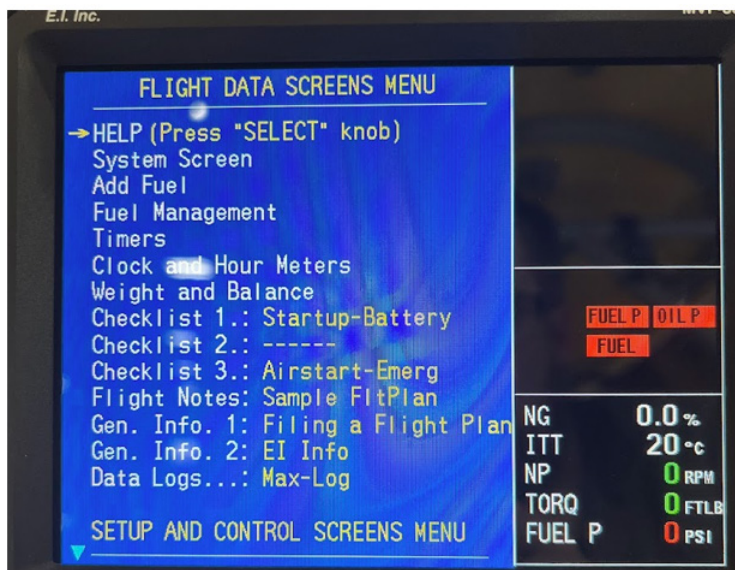

2. Scroll down and select “USB and Data Recording.” If prompted to enter a password, enter either 00100 or 00200. Press “EXIT” when password is entered.

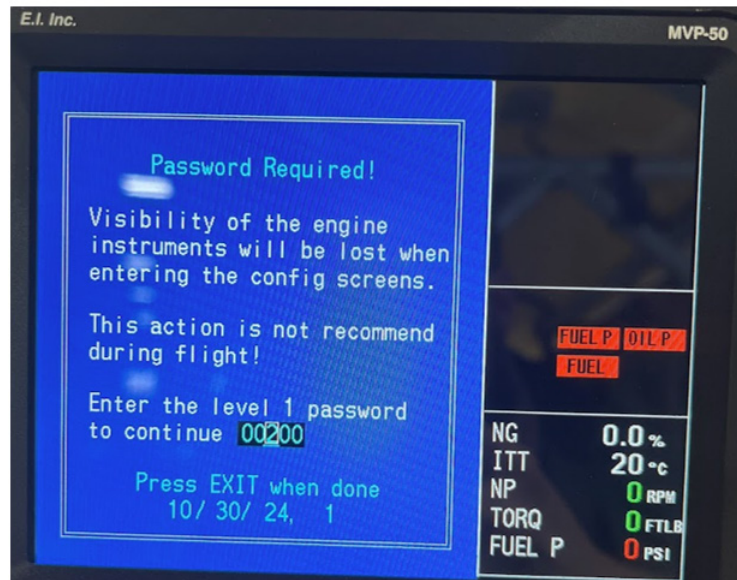

3. From the USB Flight Data File Manager screen, scroll down to the “Read All Voice Files” option and select “Yes”. DO NOT power off the MVP-50T or remove the USB flash drive until the process is complete.

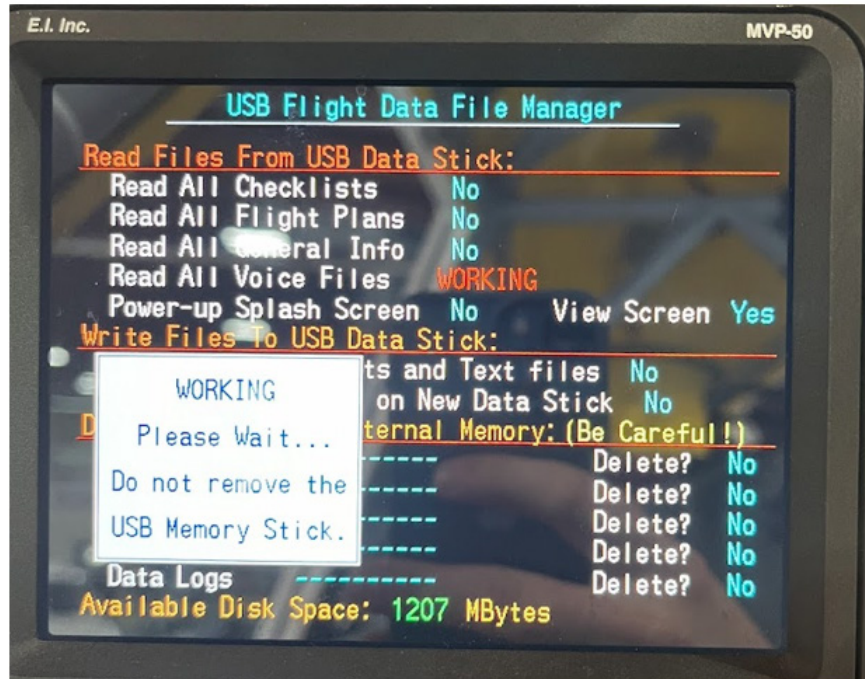

4. To test the audio file, exit to the main settings page again and select “Voice and Display Controls”.

5. On the “Voice and Display Controls” screen, scroll down to select voice file to test. The name of the Wipaire voice file will be 1012709. Once selected, select “Yes”. Voice file should play and be clear and audible.

6. To configure the audio file to play during torque and ITT exceedance, navigate to the main settings page and select the “Systems Configuration Screens Menu.” If prompted to enter a password, enter either 00100 or 00200. Press “EXIT” when password is entered.

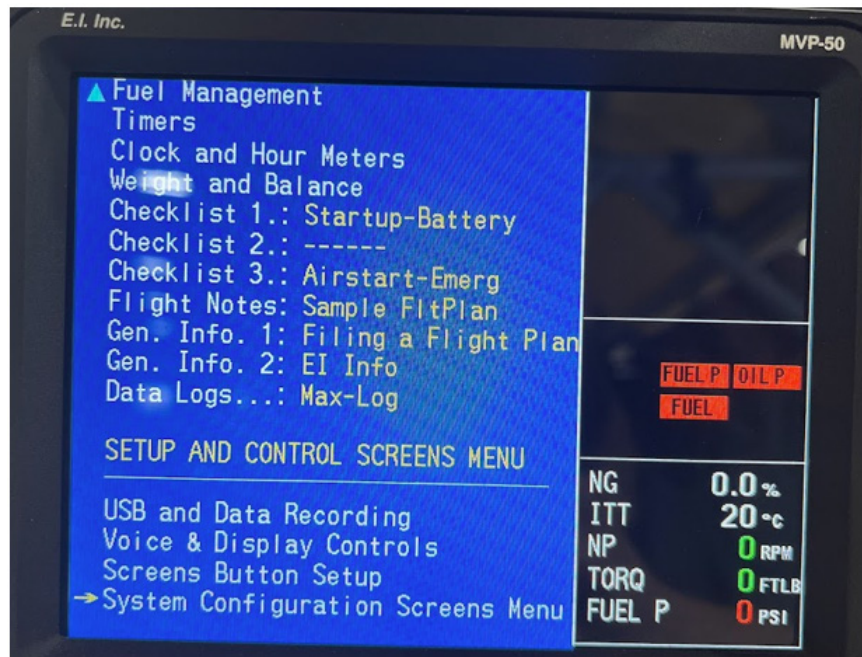

7. From the System Configuration Screens Menu, scroll down and select the “Redlines, Limits and Color Setup”.
8. For both ITT (may be shown as SP-Y) and Torque functions, select the Wipaire 1012709 as the Voice Warning file. DO NOT change any other parameters on these screens. The MVP-50T will prompt you to enter the second level passcode received from Electronics International at the beginning of these work instructions.

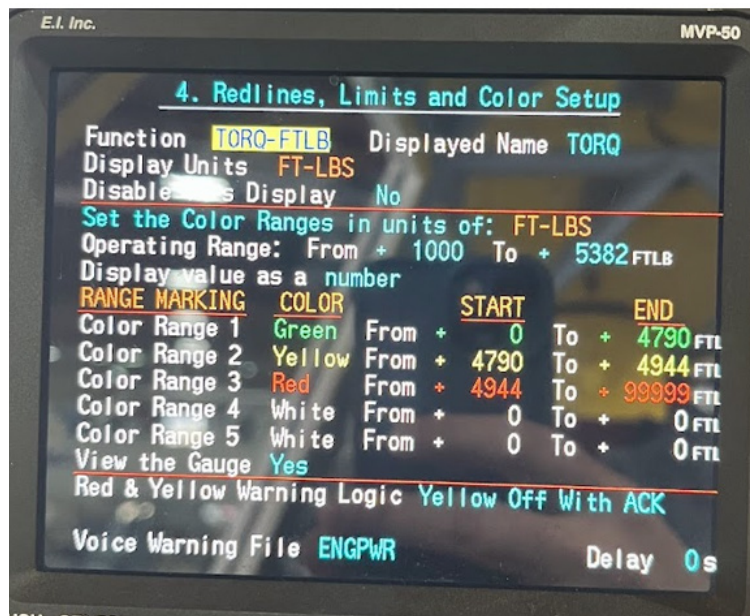
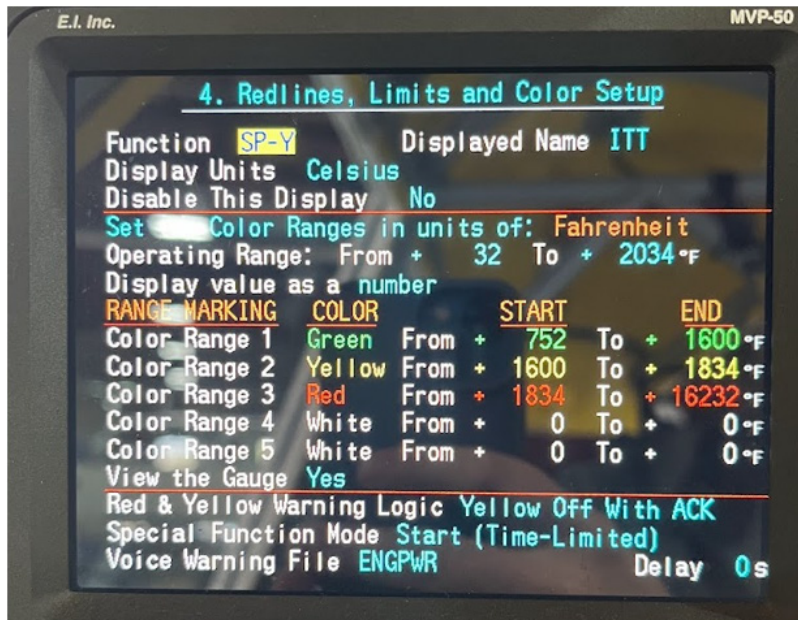

9. When complete, exit all settings screens and power off the MVP-50T.

Functional Test *Optional

If the correct test equipment is available, simulate an over-torque condition and an ITT exceedance condition. Verify that the audio files play while either parameter is at or above the set redline limit. Also verify that the “acknowledge” switch is functional and silences ALL audio alerts for 1 minute.

Aircraft Closing & Return to Service

Upon completion of inspection, enter information in Aircraft Logbook for completion of Wipaire Service Letter 266.